

**BHARTIYA SKILL DEVELOPMENT UNIVERSITY**

School of Automotive Skills

Session: 2019-20 (Summer Semester)

B. Voc. Program, 1st Semester,1st In-Sem. Examination

Course Code: AUT1101

Time: 1 Hour

Course Name: Automotive Power Train, Chassis & Suspension

Max. Marks: 20 Marks

Instruction:

1. Answer all questions from section A, each question carries one mark
2. Answer all question from section B, each question carries two mark.
3. Answer all question from section C, each question carries three mark.

Section – A**Directions:** Select any one correct answer from the given options: 05X01 = 05 Marks

- 1) The inside diameter of cylinder is called

a) Stroke	c) Bore
b) Radius	d) All of the above

- 2) When piston is at the top, the volume contained in the cylinder above the top of the piston is called.....

a) Swept volume	c) Total cylinder volume
b) Clearance volume	d) None of these

- 3) is ratio of total cylinder volume to clearance Volume.

a) Compression ratio	c) Gear ratio
b) Air fuel ratio	d) Volume ratio

- 4) The word "Automobile" means:

a) Auto-drive	c) Self-controlling
b) Self-Moving	d) All of the above

- 5) Which of the following is not an internal combustion engine?

a) Petrol engine	c) 4 stroke engine
b) Diesel engine	d) Gas turbine

Section – B

03X02 = 06 Marks

- 6) Define the term "Automobile".
- 7) What are the advantages of IC engine over EC engine?
- 8) Draw a labelled diagram of 4-wheel drive vehicle.



BHARTIYA SKILL DEVELOPMENT UNIVERSITY

Section – C

03X03 = 09 Marks

- 9) Discuss general service procedures of a vehicle.
- 10) What are the various safety practices that must be followed in an automobile workshop?
- 11) Explain the working of 4-stroke diesel engine with the help of a diagram.

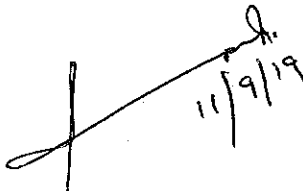
11/9/19

**BHARTIYA SKILL DEVELOPMENT UNIVERSITY**

School of Automotive Skills

Session: 2019-20 (Summer Semester)

B. Voc. Program, 3rd Semester,1st In-Sem. Examination

Course Code: AUT1101

Time: 1 Hour

Course Name: Automotive Power Train, Chassis & Suspension

Max. Marks: 20 Marks

Instructions:

1. Answer all questions from “**Section-A**”, each question carries 01 mark.
2. Answer all questions from “**Section-B**”, each question carries 02 marks.
3. Answer all questions from “**Section-C**”, each question carries 03 marks.

Section – A**Directions:** Select any one correct answer from the given options: 05X01 = 05 Marks

1) The inside diameter of cylinder is called

- | | |
|-----------|---------------------|
| a) Stroke | c) Bore |
| b) Radius | d) All of the above |

Ans: c)

2) When piston is at the top, the volume contained in the cylinder above the top of the piston is called.....

- | | |
|---------------------|--------------------------|
| a) Swept volume | c) Total cylinder volume |
| b) Clearance volume | d) None of these |

Ans: b)

3) is ratio of total cylinder volume to clearance Volume.

- | | |
|----------------------|-----------------|
| a) Compression ratio | c) Gear ratio |
| b) Air fuel ratio | d) Volume ratio |

Ans: a)

4) The word “Automobile” means:

- | | |
|----------------|---------------------|
| a) Auto-drive | c) Self-controlling |
| b) Self-Moving | d) All of the above |

Ans: b)

5) Which of the following is not an internal combustion engine?

- | | |
|------------------|--------------------|
| a) Petrol engine | c) 4 stroke engine |
| b) Diesel engine | d) Gas turbine |

Ans: d)

BHARTIYA SKILL DEVELOPMENT UNIVERSITY

Section – B

03X02 = 06 Marks

6) Define the term “Automobile”.

Ans: An automobile is a self-moving vehicle driven by its own motive power. Eg. Car, bus jeep, truck, etc.

7) What are the advantages of IC engine over EC engine?

Ans. Advantages of Reciprocating internal combustion engines over external combustion engines:

1. Overall all efficiency is high.
2. Greater Mechanical Efficiency.
3. Weight to power ratio is generally low.
4. Generally lower initial cost.
5. Easy starting from cold conditions.

These units are compact and thus require less space

8) Draw a labelled diagram of 4-wheel drive vehicle.

Ans:

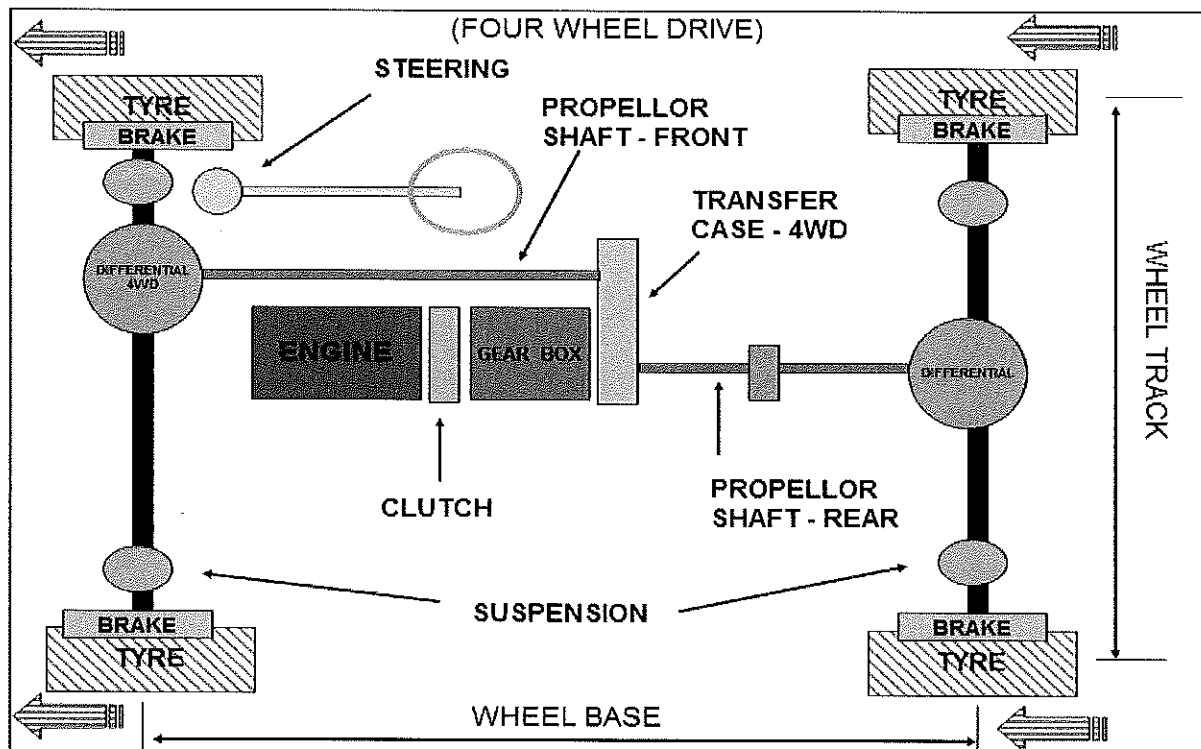

Section – C

03X03 = 09 Marks

9) Discuss general service procedures of a vehicle.

Ans: - The general service includes:

1. Engine oil change
2. Oil filter change
3. Replace the fuel filter
4. Air filter change
5. Check both rear and front brake
6. Check the level of brake and clutch fluid

BHARTIYA SKILL DEVELOPMENT UNIVERSITY

7. Grease and lubricate components
8. Check the proper operation of all the lights, wiper etc.
9. Check the error code in ECU and take corrective action.
10. Wash the vehicle and clean the interiors.

10) What are the various safety practices that must be followed in an automobile workshop?

Ans:

The various safety practices are as follows:

- Always wear a safety helmet in the workshop, especially when working under the vehicle.
- Wear cotton hand gloves when working or carrying out repairs or service on a vehicle.
- Wear face masks to cover your nose and mouth.
- Wear safety goggles when working under the vehicle.
- Do not wear rings, watches and loose clothes when working on a vehicle.
- Keep the shop floor clean and tidy.
- Wear safety shoes in the workshop.
- Use specific and tool for a specific job.

11) Explain the process of 4-stroke diesel engine with the help of a diagram.

Ans:

SUCTION STROKE: With the movement of the piston from T.D.C. to B.D.C. during this stroke, the inlet valve opens and the air at atmospheric pressure is drawn inside the engine cylinder; the exhaust valve however remains closed. This operation is represented by the line 5-1

COMPRESSION STROKE: The air drawn at atmospheric pressure during the suction stroke is compressed to high pressure and temperature as the piston moves from B.D.C. to T.D.C. Both the inlet and exhaust valves do not open during any part of this stroke. This operation is represented by 1-2

POWER STROKE OR EXPANSION STROKE: As the piston starts moving from T.D.C to B.D.C, the quantity of fuel is injected into the hot compressed air in fine sprays by the fuel injector and it (fuel) starts burning at constant pressure shown by the line 2-3. At the point 3 fuel supply is cut off. The fuel is injected at the end of compression stroke but in actual practice the ignition of the fuel starts before the end of the compression stroke. The hot gases of the cylinder expand adiabatically to point 4. Thus doing work on the piston.

EXHAUST STROKE: The piston moves from the B.D.C. to T.D.C. and the exhaust gases escape to the atmosphere through the exhaust valve. When the piston reaches the T.D.C. the exhaust valve closes and the cycle is completed. This stroke is represented by the line 1-5.

BHARTIYA SKILL DEVELOPMENT UNIVERSITY

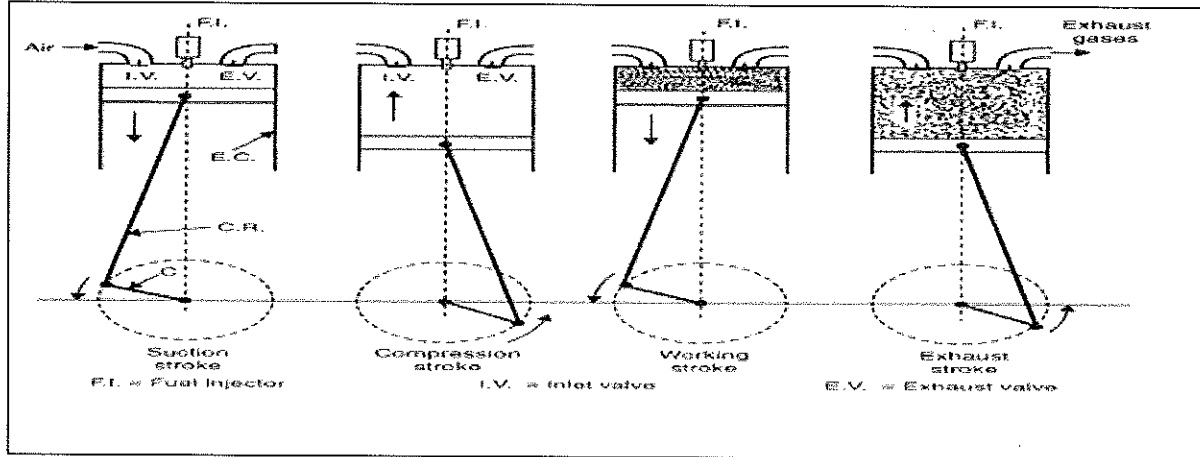



BHARTIYA SKILL DEVELOPMENT UNIVERSITY

School of Automotive Skills
Session: 2019-20 (Summer Semester)
B. Voc. Program, 1st Semester
1st In-Sem. Examination

Course Code: AUT1102

Course Name: Automotive Wheel Care and Steering System

Time: 1 hour

Max. Marks: 20

Instruction:

1. Answer all questions from section – A, each question carries one mark.
2. Answer all questions from section – B, each question carries two marks.
3. Answer all questions from section – C, each question carries three marks.

Section – A

(5X1 marks)

Q 1. Weight Positioning Measurement (WPM) is associated with which of the following:

- A. Wheel Alignment
- B. Tyre Changer
- C. Wheel Balancing
- D. Tyre Balancing

Q 2. Allen Wrench are available in:

- A. L- Shape
- B. T- Shape
- C. Both L & T Shape
- D. Neither L nor T Shape

Q 3. The machine used to help technicians to dismount and to mount tires with automobile wheels is:

- A. Wheel Aligner
- B. Wheel Changer
- C. Tyre Changer
- D. Tyre Balancer

Q 4. The purpose of the steering system of an Automobile is to:

- A. Achieve angular motion of the wheels
- B. Provide Directional Stability during straight motion
- C. Straight Ahead recovery after completing the turn
- D. All of the Above

Q 5. Which one of the following is not a tool?

- A. Pincers
- B. Screws
- C. Wrench
- D. Pliers

Section – B

(3X2 marks)

Q 6. What are the Job Responsibilities of a wheel care technician in an Automotive Workshop?

Q 7. What is the difference between wheel balancing and wheel alignment?



Q 8. What essential safety equipment are required while working in the wheel care section of an Automotive Workshop?

Section – C

(3X3 marks)

Q 9. Explain the following equipment:

- a) Wheel Balancer
- b) Tyre Changer

Q 10. Explain any six tools used in wheel care section with their applications.

Q 11. Explain Wheel Alignment machine along with machine specifications.



BHARTIYA SKILL DEVELOPMENT UNIVERSITY

School of Automotive Skills
Session: 2019-20 (Summer Semester)
B. Voc. Program, 1st Semester
1st In-Sem. Examination
Solution

Course Code: AUT1102
Course Name: Automotive Wheel Care and Steering System

Time: 1 hour
Max. Marks: 20

Section – A

Q 1. Weight Positioning Measurement (WPM) is associated with which of the following:

- A. Wheel Alignment
- B. Tyre Changer
- C. Wheel Balancing
- D. Tyre Balancing

Answer – C

Q 2. Allen Wrench are available in:

- A. L- Shape
- B. T- Shape
- C. Both L & T Shape
- D. Neither L nor T Shape

Answer – C

Q 3. The machine used to help technicians to dismount and to mount tires with automobile wheels is:

- A. Wheel Aligner
- B. Wheel Changer
- C. Tyre Changer
- D. Tyre Balancer

Answer – C

Q 4. The purpose of the steering system of an Automobile is to:

- A. Achieve angular motion of the wheels
- B. Provide Directional Stability during straight motion
- C. Straight Ahead recovery after completing the turn
- D. All of the Above

Answer – D

Q 5. Which one of the following is not a tool?

- A. Pincers
- B. Screws
- C. Wrench
- D. Pliers

Answer – B

Section – B

Q 6. What are the Job Responsibilities of a wheel care technician in an Automotive Workshop?

Answer – Roles and responsibilities of technician in wheel care

1. An automotive service technician (or auto mechanic) is someone who inspects, maintains, repair and replace like tyre, brake etc.
2. Test parts and systems to ensure they are working properly.
3. Identify mechanical problems, often by using computerized diagnostic equipment.
4. Follow checklists to ensure that all critical parts are examined.
5. Perform basic care of tyre rotations.

BHARTIYA SKILL DEVELOPMENT UNIVERSITY

6. Repair or replace worn parts, such as brake pads and wheel bearings.
7. Disassemble and reassemble parts.
8. Use testing equipment to ensure that repairs and maintenance are effective.
9. Explain to clients their automotive problems and the repairs done on their vehicles.

Q 7. List out the major components of a steering system.

Answer –

- Steering Wheel
- Steering Column & Shaft
- Universal Joint
- Steering Gear Box
- Steering Pump
- Linkage (Tie Rod)
- Rubber Bush

Q 8. What essential safety equipment are required while working in the wheel care section of an Automotive Workshop?

Answer –

- Safety goggles:

If you are working in workshop, then you should always wear safety glasses. Because some time stones, dust particles available on wheel and when wheel is rotating then it gone into your eyes so you must wear safety glasses with side protection.

- Safety gloves:

This type of glove can provide protection against some moderate concentrated chemicals. The risk of cuts and abrasions also can be minimized by wearing gloves.

- Helmet:

Helmet will protect the user's head against: impact from objects falling from above, by resisting and deflecting blows to the head.

- Safety shoes:

A steel-toe boot is protective reinforcement in the toe which protects the foot from falling objects or compression, usually combined with a mid-sole plate to protect against punctures from below.

Section – C

Q 9. Explain the following equipment:

- a) Wheel Balancer.
- b) Tyre Changer.
- c) Wheel Aligner.

Answer a)–

Wheel Balancer

1. Wheel balancing, also known as Tyre balancing, is the process of equalizing the weight of the combined tire and wheel assembly.
2. Wheel balancing is the process of balancing the weight of a tire and wheel assembly so that it travels evenly at high speeds.
3. Balancing requires putting a mounted wheel and tire on a balancer, which centers the wheel and spins it to determine where the weights should go.
4. Every time a wheel is first mounted onto a vehicle with a new tire, it has to be balanced.

BHARTIYA SKILL DEVELOPMENT UNIVERSITY

5. The goal is to make sure the weight is evenly distributed throughout each of the wheels and tires on a vehicle. This process evens out heavy and light spots in a wheel, so that it rotates smoothly.
6. If there is even a slight difference in weight in the wheels, it will cause enough momentum to create a vibration in the car.

Answer b)-

Tyre Changer

1. Tyre changer is a machine which is used to change or replace the tyre.
2. Tyre changer is a machine used to help technicians dismount and mount tires with automobile wheels.
3. Different tire changers allow technicians to replace tires on automobiles, motorcycles and heavy-duty trucks.
4. New tire and wheel technology has improved certain tire changers performance.

Answer c)-

Wheel Aligner

1. Alignment refers to an adjustment of a vehicle's suspension – the system that connects a vehicle to its wheels. It is not an adjustment of the tires or wheels themselves.
2. The key to proper alignment is adjusting the angles of the tires which affects how they make contact with the road.
3. With caster and camber adjusted, then adjust toe angles. Restart the car, remove the steering wheel-lock, turn the steering wheel back and forth a couple times, then re-center and replace the steering wheel-lock. Recheck alignment specifications, and then readjust angles as necessary.

Q 10. Explain any six tools used in wheel care section with their applications.

Answer –

1. **Open-end spanner:** This one-piece wrench is made double-ended with differing size openings for opposite faces of bolts or nuts. The U-shaped opening on each end provides grip for objects by flipping the wrench over to use the opposite side.
2. **Combination spanner:** The combination wrench is a multi-purpose tool with the open-end for tightening and loosening in small spaces and the box-end for leverage and a firm grip around nuts and bolts.
3. **Allen set:** These wrenches have L or T-shaped handles with hexagonal shaped ends matching openings to bolts or screws. Though they are small, they are typically used for pairing and holding objects together.
4. **Socket wrench:** Used to turn a fastener, a socket wrench has a socket (hollow cylinder) attached to the end of the handle that is fitted over nuts and bolts to tighten and loosen at many angle.
5. **Adjustable wrench:** If you don't have the right size of wrench for a project or repair, an adjustable wrench can save the day. Also known as a crescent wrench. It should only be used when necessary. Due to their versatility, they can tend to slip and slide along bolts when too much force is used.
6. **Slip joint pliers:** Slip joint pliers are pliers whose pivot point or fulcrum can be moved to increase the size range of their jaws. Most slip joint pliers use a mechanism that allows sliding the pivot point into one of several positions when the pliers are fully opened.

Q 11. Discuss all the functions performed by a steering system in an Automobile.

Answer – Following are the function of a steering system:

- The primary function of the steering system is to achieve angular motion of the front wheels to negotiate a turn.
- To provide directional stability of the vehicle when going straight ahead.
- To minimize wear and tear of tyres.



BHARTIYA SKILL DEVELOPMENT UNIVERSITY

- To facilitate straight ahead recovery after completing a turn.
- To providing perfect rolling motion of the road wheels at all times.
- To absorb a major part of the road shocks thereby preventing them to get transmitted to the hands of the driver.



BHARTIYA SKILL DEVELOPMENT UNIVERSITY

School of Automotive Skill
I Semester, 1st In-Sem. Examination
B. Voc. Program, Summer Semester (2019-20)

Course Code : AUT1103

Time : 1 Hour

Course Name: Automotive Body Repair

Max. Marks : 20

Instructions:

1. Answer all questions from section A, each question carries one mark.
2. Answer all questions from section B, each question carries two mark.
3. Answer all questions from section C, each question carries three mark.

Section – A

(5x1=05) Marks

1. Nose section of the car is also known as
 - a. Doghouse
 - b. Greenhouse
 - c. Cathouse
 - d. None of the above
2. A structure design in which the frame and body are built as a single integrated structure is called
 - a) Backbone
 - b) Ladder
 - c) Monocoque
 - d) All of the above
3. Which of the following is not a part of body sections?
 - a) Bonnet
 - b) Fender
 - c) Spoiler
 - d) Wheel
4. Cabriolet is also known by the name
 - a) Convertible
 - b) Coupe
 - c) Saloon
 - d) Estate
5. What is the colour code of warning sign?
 - a) Blue
 - b) Green
 - c) Yellow
 - d) Red



BHARTIYA SKILL DEVELOPMENT UNIVERSITY

Section – B

03X02 = 06 Marks

6. Write the different tools and equipment used in Body Repair Shop?
7. What are the safety equipments technician needs to put on before getting into the body repair shop?
8. Explain 3 safety signs with appropriate symbol.

Section – C

03X03 = 09 Marks

9. Describe various types of available chassis in brief.
10. Explain the different types of automotive body styles in India with examples.
11. Discuss the types of car body pillar.

School of Automotive Skill
I Semester, 1st In-Sem. Examination
B. Voc. Program, Summer Semester (2019-20)

Course Code : AUT1103

Time : 1 Hour

Course Name: Automotive Body Repair

Max. Marks : 20

Instructions:

1. Answer all questions from section A, each question carries one mark.
2. Answer all questions from section B, each question carries two mark.
3. Answer all questions from section C, each question carries three mark.

Section – A

(5x1=05) Marks

1.) Nose section of car is also known as

- | | |
|---------------|----------------------|
| a) Doghouse | c) Cathouse |
| b) Greenhouse | d) None of the above |

Ans: - a) Doghouse

2.) A structure design in which the frame and body are built as a single integrated structure is called

- | | |
|-------------|---------------------|
| a) Backbone | c) Monocoque |
| b) Ladder | d) All of the above |

Ans: - c) Monocoque

3.) Which of the following is not a part of body sections?

- | | |
|-----------|------------|
| a) Bonnet | c) Spoiler |
| b) Fender | d) Wheel |

Ans: - d) Wheel

4.) Cabriolet is also known by the name

- | | |
|----------------|-----------|
| a) Convertable | c) Saloon |
| b) Coupe | d) Estate |

Ans: - a) Convertable

5.) What is the colour code of warning sign?

- | | |
|----------|-----------|
| a) Blue | c) Yellow |
| b) Green | d) Red |

Ans: - d) Red

Section-B

(3x2=06) Marks

Q.6. Write the different tools and equipment used in Body Repair Shop?

Ans: - The following tools and equipment are used in Body Repair Shop:

- Pneumatic tools
- Dent puller
- Grinder
- Metal-cutting guns
- Plasma cutters
- Heavy-duty hydraulic jacks
- Hammers & Mallet
- Files, pliers, wrenches, and screwdrivers.

Q.7. What are the safety equipments technician needs to put on before getting into the body repair shop?

Ans: - The major safety equipments technician needs to put on before getting into the body repair shop are as follows:

- Helmet
- Safety goggles
- Safety shoes
- Nose masks
- Gloves
- Ear plug(while grinding)

Q.8. Explain 3 safety signs with appropriate symbol.

Ans.

1.



2.



3.



Section-C

(3x3=09) Marks

Q.9. Describe various types of available chassis in brief.

Ans: - Chassis frame is the basic frame work of the automobile. It supports all the parts of the automobile attached to it. All the parts related to automobile like engine, transmission, steering, suspension, braking system, etc. are attached to it. It is made of steel and steel alloy, carbon steel or Aluminium alloy. Chassis are classified as follows:

a) Ladder chassis:

It is one of the oldest forms of automotive chassis that is still used by most of the SUVs till today. Ladder chassis resembles a shape of a ladder having two longitudinal rails inter linked by several lateral and cross braces.

b) Backbone chassis:

This type of automotive chassis is strong and powerful enough to provide support smaller sports car.

c) Monocoque chassis:

Monocoque Chassis is a one-piece structure that prescribes the overall shape of a vehicle. This type of automotive chassis is manufactured by welding floor pan and other pieces together.

Q.10. Explain the different types of automotive body styles in India with examples.

Ans: -

Different Types of Car Body Styles are:

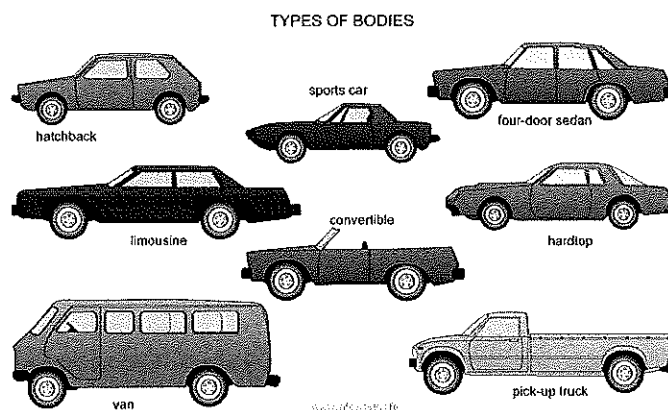

Hatchback

A hatchback is a car with a sloping back and a hinged rear door that opens upwards. These cars differ from SUVs, MPVs or vans in that they are usually much more compact. Hatchbacks usually have seating for four-five people is almost always a tight squeeze. An example of a hatchback is the Maruti Suzuki Swift.

Sedan

A sedan, also called a saloon, is a passenger car with a bonnet covering the engine and a separate boot for luggage at the rear. This is one of the most popular body styles of cars today, with seating for at least four people. A sedan design is also known as a 'three-box' design. An example of a sedan is the Honda City.

Coupe

Coupes are often the sporty variants of saloon cars, with doors reduced from 4 to 2. However, the coupe body style varies from carmaker to carmaker, and now there are even four-door coupes like the Mercedes-Benz CLS-Class. The name 'coupe' comes from the French verb 'Couper', which means 'to cut'. An example of a two-door coupe is the Audi A5.

Estate

Estates, or station wagons, have a body style similar to a sedan, but with an extended rear luggage or cargo area. These cars have a two-box design with the passenger compartment extending over where the boot would have been in a saloon. They are usually based on sedans and often share the same frontal design. Estates are not very common in India, but an example is the Skoda Octavia Combi.

SUV

An SUV, or Sports Utility Vehicle, is similar to an estate, but usually bigger and higher off the ground. SUVs are often offered with four-wheel-drive and are designed for both on- and off-road use. Some have the towing capacity of a pickup, and offer the passenger carrying capacity of a minivan or large sedan. An example of an SUV is the Ford Endeavour.

MPV

MPVs, or Multi-Purpose Vehicles, feature a one- or two-box design and are taller than station wagons. They often see estate-like interior appointments and are also called people-carriers, people-movers, minivans, or MUVs (Multi-Utility Vehicles). They are designed to be spacious and usually get three rows of seats with seating for 7 or more. An example of an MPV is the Toyota Innova.

Crossover

A crossover is a vehicle built on a car platform but often with features of an SUV like increased ground clearance and a higher seating position. Crossovers are typically designed only for light off-roading. An example of a crossover is the recently-launched Fiat Aventura.

Pickup

A pickup is a light motor vehicle with an open rear cargo area known as a 'bed'. These are extremely popular in the US, and feature factory-built integrated beds. The term also applies to coupe utility vehicles, where they are based on a car chassis or a dedicated platform. Pickups are called 'utes' in Australia and New Zealand. They are often available with two or four doors for the passenger compartment, and are called single-cab pickups and double-cab pickups respectively. An example of a pickup is the Tata Xenon, which features a double-cab design.

Q.11. Discuss the types of car body pillar.

Ans: - Just like in civil construction, a car's pillars support its roof. To identify them, one needs to look at the car from one of its sides. The sloping pillar between which the windshield glass is fixed is the A Pillar. The second pillar from the front is the B Pillar, onto which the front doors click shut. The rear doors are hinged to the B Pillar as well. The C Pillar is behind the rear seat, and is the third and final pillar when it comes to hatchbacks, sedans, and small SUV's. Larger cars with a third row of seating, like Minivans and Large SUV's, have a fourth D Pillar, which is behind the third row.

Typically, thicker A and C Pillars (D, in case of Minivans and SUV's) are disliked as they block the driver's field of vision at the front and back respectively.

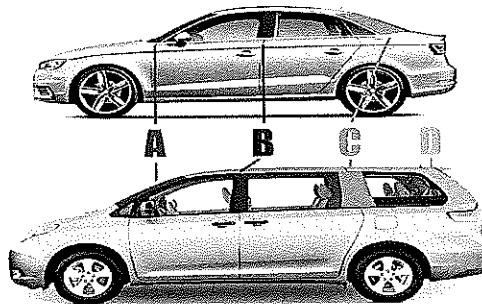

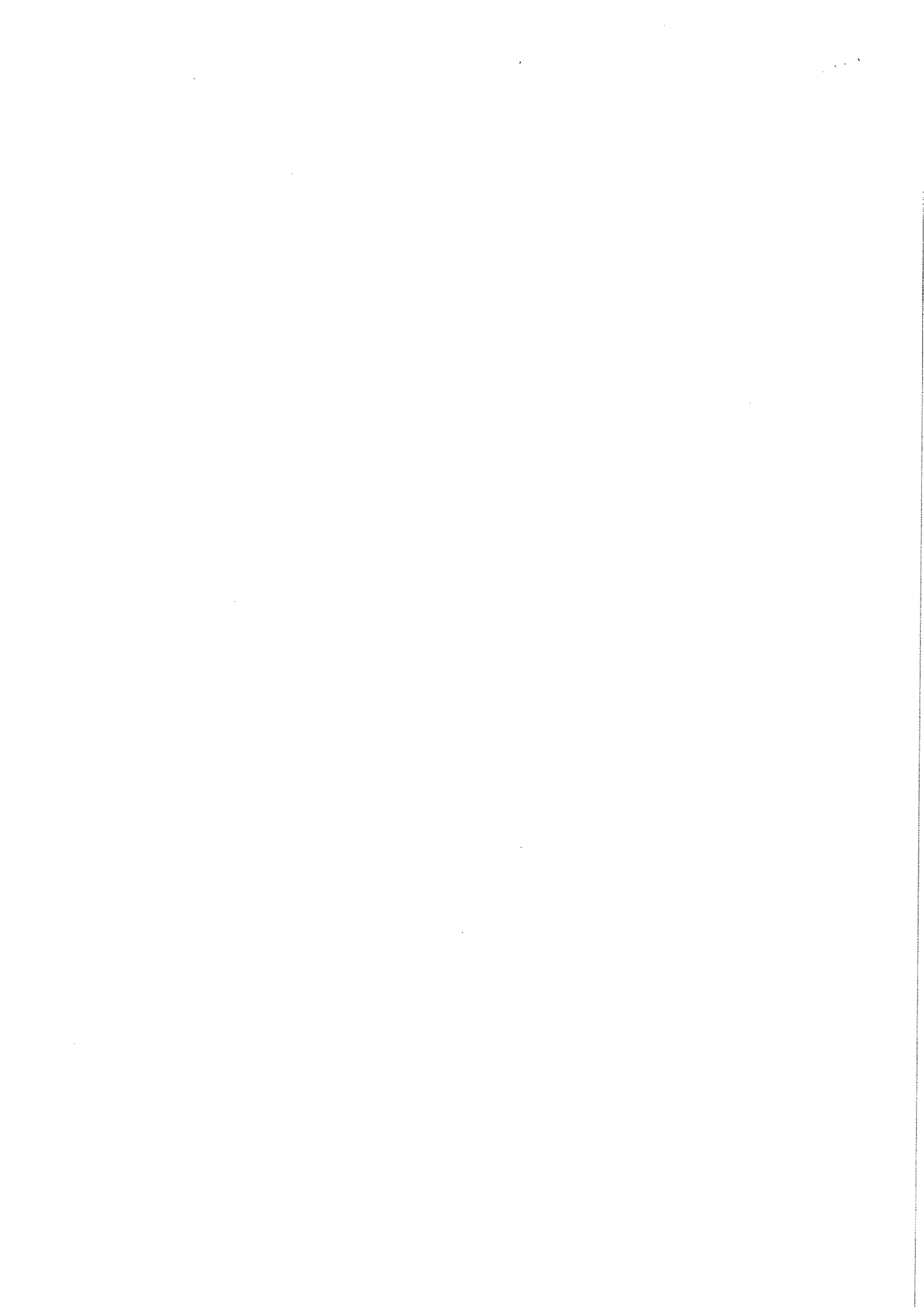



School of Automotive Skills
Session: 2019-20 (Summer Semester)
B. Voc. Program, 1st Semester,
1st In-Sem. Examination

Course Code: AUT1104

Time: 1 Hour

Course Name: Automotive Spray Painting

Max. Marks: 20

Instruction: Attempt all questions.

Section A: Select the one correct option from the given options in the following questions.

Section – A

05X01 = 05 Marks

Q-1. Which substance acts as a bonding agent?

- a. Putty
- b. Primer
- c. Hardener
- d. None of these

Q-2. Which place is used to mix the paint?

- a. Inside Paint booth
- b. Paint mixing room
- c. Outside paint booth
- d. None of the above

Q-3. Which place is used for final painting?

- a. Paint booth
- b. Sanding room
- c. Paint mixing room
- d. None of the above

Q-4. Sanding process is required to...

- a. Even the surface
- b. Fill the holes
- c. Both (a) and (b)
- d. None of the above

Q-5. The substance used as an undercoat during painting is...

- a. Primer
- b. Putty
- c. Thinner
- d. None of these

Section – B

03X02 = 06 Marks

Q-6. Write short notes on paint mixing room.

Q-7. What is putty? also write its different types of putty.

Q-8. What are the job responsibilities of a paint shop technician?

Section – C

03X03 = 09 Marks

Q-9. What is primer? Explain different properties of primer.

Q-10. What is dry sander? Explain different components of pneumatic dry sander.

Q-11. What is sanding? Explain types of sanding.

[Handwritten Signature]
11/9/19



School of Automotive Skills
Session: 2019-20 (Summer Semester)
B. Voc. Program, 1st Semester,
1st In-Sem. Examination

Course Code: AUT1104

Time: 1 Hour

Course Name: Automotive Spray Painting

Max. Marks: 20

Instruction: Attempt all questions.

Section A: Select the one correct option from the given options in the following questions.

Section – A

05X01 = 05 Marks

Q-1. Which substance acts as a bonding agent?

- a. Putty
- b. Primer
- c. Hardener
- d. None of these

Ans: (A) primer

Q-2. Which place is used to mix the paint?

- a. Inside Paint booth
- b. Paint mixing room
- c. Outside paint booth
- d. None of the above

Ans: (B) Paint mixing room

Q-3. Which place is used for final painting?

- a. Paint booth
- b. Sanding room
- c. Paint mixing room
- d. None of the above

Ans: (A) Paint Booth

Q-4. Sanding process is required to...

- a. Even the surface
- b. Fill the holes
- c. Both (a) and (b)
- d. None of the above

Ans: (A) Even the Surface

Q-5. The substance used as an undercoat during painting is...

- a. Primer
- b. Putty
- c. Thinner
- d. None of these

Ans: (A) Primer

Section – B

03X02 = 06 Marks

Q-6. Write short notes on paint mixing room?

Ans: Paint mixing room is a place where we mix the the paints according to the requirements. It should have colour-corrected artificial lighting and downdraft ventilation. Paint mix rooms are generally located next to the spray booth to maximise painter productivity.



BHARTIYA SKILL DEVELOPMENT UNIVERSITY

Q-7. What is putty and write its different types?

Ans: Putty is a material with high plasticity, similar in texture to clay.

- Painter's Putty is typically used for filling holes, minor cracks, scratches etc.

There are three types of putty/body fillers:-

1. Standard
2. Mid-range
3. Premium

Q-8. What are the responsibilities of a paint shop technician?

Ans: To carry all types of vehicle body refinishing work like:-

1. Pre -paint preparation
 2. Priming and painting
 3. Paint inspection
 4. Rectification of defects
- To identify and utilise the correct methods of working by using your experience, skills, training and industry knowledge,
 - To keep your skills up-to-date by making appropriate efforts to acquire adequate knowledge of new vehicles.

To identify and report all apparent faults considered to be advisable in the interest of safety and reliability

Section – C

03X03 = 09 Marks

Q-9. What is primer? Explain different properties of primer.

Ans: Primers are the most common undercoats used when refinishing car bodies. • Primer is a bonding agent which enables a bond between the surface underneath it and the paint that will be sprayed on top.

Basically, primers are categorized in 2 parts: -

1. 1-k primers
2. 2-k primers

Adhesion – they provide a strong bond between the sheet metal or old paint and the new paint

- Rust resistance – they resist the formation of rust where they adhere to the sheet metal
- Build– they're able to fill sanding and grinding marks in old paint, sheet metal and fillers
- Sanding ease – they can be sanded smooth and levelled quickly and easily
- Hold out – they prevent the paint from soaking in, which results in a dull finish
- Drying speed – a good high-build primer should be ready to sand in as little as 30 minutes

Q-10. What is dry sander? Explain different components of pneumatic dry sander.

Ans: A sander is a tool that's used to smooth a vehicle's surface before painting.

- Sanders are useful for a variety of tasks, including removing old paint and varnish, buffing, and polishing.

There are three primary types of sanders for cars:

- Air sanders



Hand sanders

- Electric sanders

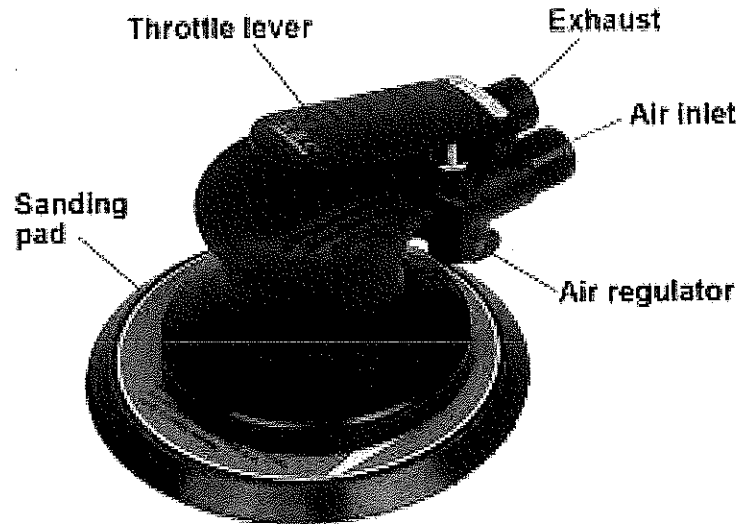

Q-11. What is sanding? Explain types of sanding.

Ans: Sanding removes the top layer of your car's paint using abrasive materials. It also helps to make the surface even after the putty application by removing extra putty from the surface.

Function of sanding in car repairing

Removal of material. • Preparation of surfaces (adhesion promoter). • Smoothing and surface embellishment. • Reparation of defects.

Types of sanding

1. Manual sanding. • Wet sanding • Dry sanding

2. Automatic sanding.

Manual sanding: • Manual or hand sanding is the oldest known method of sanding used. • It only uses when the machine cannot be used, such as sanding small and hard surfaces access, etc..

The hand sanding can be done using 2 techniques: • Water sanding or wet sanding • Dry sanding.

1. Water sanding: - • Water or wet sanding is done by immersing the sandpaper in a bucket of water. • It produces less dust, longer life of the sandpaper and allows obtain a smooth surface compared with dry sanding.

2. Dry sanding: - • Dry sanding is applied directly on the surface. • This type of sanding causes excessive dust resulting abrasive action of the grain on the surface.

Automatic sanding: • Automatic sanding is done by sanding machines called as sanders. • Greatly reduces the effort and time of work compared to hand sanding. • The main disadvantage is that sanders not arrive well in difficult areas or edges, where it is necessary sand by hand.





Registration No.:

BHARTIYA SKILL DEVELOPMENT UNIVERSITY

School of Automotive Skills
Session 2019-20, Summer Semester
B. Voc. Program, 1st Semester,
1st In-Sem. Examination

Course Code: AUT1105

Time: 1 Hour

Course Name: Automotive Electrical Fundamentals & Comfort System

Max. Marks: 20

Instruction:

1. Answer all questions from section – A, each question carries one mark.
2. Answer all questions from section – B, each question carries two marks.
3. Answer all questions from section – C, each question carries three marks.

Section – A

05x01 = 05 Marks

Q 1. Which measuring instrument is commonly used in the automotive workshops for auto-electrical measurements?

- | | |
|---------------|------------------|
| A. Ohmmeter. | C. Oscilloscope. |
| B. Voltmeter. | D. Multimeter. |

Q 2. Among the below options which material is a bad conductor of electricity?

- | | |
|-----------|------------|
| A. Brass. | C. Copper. |
| B. Glass. | D. Silver. |

Q 3. The charging system:

- A. Provides all electrical energy to operate the electrical system while the engine is running.
- B. Restores the energy to the battery after starting the engine.
- C. Uses the principle of magnetic induction to generate electrical power.
- D. All of the above.

Q 4. What is the relationship between resistance and length of wires?

- A. If length increases than resistance increases.
- B. If length decreases than resistance increases.
- C. Both of the above.
- D. None of the above.

Q 5. Why we use metallic shield for power cables in an automotive electrical?

- A. To make it attractive.
- B. To increase the electrical conductivity.
- C. To protect the wire from the external forces.
- D. All of the above.

Section – B

03X02 = 06 Marks

Q 6. Differentiate between conductors and insulators.

Q 7. What do you understand by shielding of wires in an automotive electrical?

Q 8. What do you understand by capacitors? Name any four applications of capacitors in an automotive electrical.

Section – C

03X03 = 09 Marks

Q 9. Explain the followings:

- a) Wires.
- b) Fuses.
- c) Relays.

Q 10. Find out the missing units in the electrical circuit:

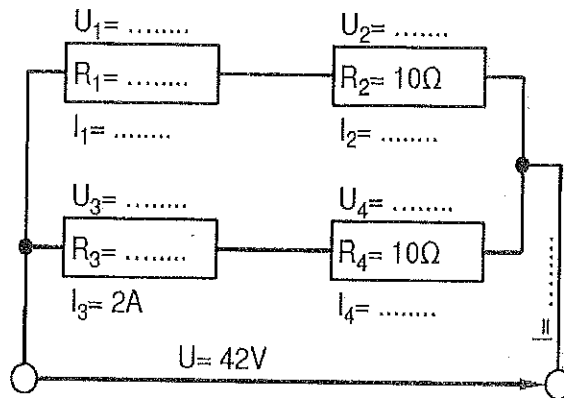

Q 11.

- a) One cable is damaged on the insulation. A residual current of 0.5mA flows at a voltage of 28V. What is the resistance at the damaged area?
- b) Draw and calculate the missing units of the given circuit:

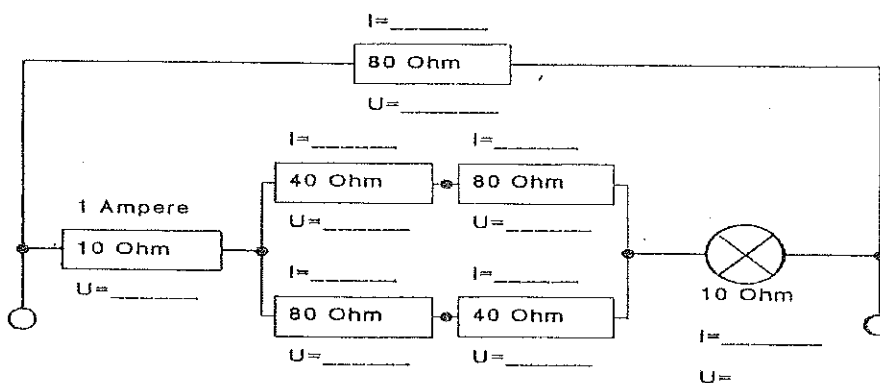

Handwritten signature and date: 11/9/19



BHARTIYA SKILL DEVELOPMENT UNIVERSITY

School of Automotive Skills
Session 2019-20, Summer Semester
B. Voc. Program, 1st Semester,
1st In-Sem. Examination

Course Code: AUT1105

Course Name: Automotive Electrical Fundamentals & Comfort System

Section – A

05x01 = 05 Marks

Q 1. Which measuring instrument is commonly used in the automotive workshops for auto-electrical measurements?

Answer: D. Multimeter.

Q 2. Among the below options which material is a bad conductor of electricity?

Answer: B. Glass.

Q 3. The charging system:

Answer: D. All of the above.

Q 4. What is the relationship between resistance and length of wires?

Answer: B. If length decreases than resistance increases.

Q 5. Why we use metallic shield for power cables in an automotive electrical?

Answer: C. To protect the wire from external forces.

Section – B

03X02 = 06 Marks

Q 6. Differentiate between conductors and insulators.

Answer:

Difference between conductors and insulators

Conductors	Insulators
<ul style="list-style-type: none"> • A conductor allows current to flow through it. 	<ul style="list-style-type: none"> • Insulators don't allow current to flow through it.

• Electric charge exists on the surface of conductors.

• Conductors don't store energy when kept in a magnetic field.

• Thermal conductivity (heat allowance) of a conductor is very high.

• The resistance of a conductor is very low.

• Copper, Aluminium, and Mercury are some conductors.

• Conductors are used in making electrical equipment.

• Electric charges are absent in insulators.

• Insulators store energy when kept in a magnetic field.

• Thermal conductivity of an insulator is very low.

• The resistance of an insulator is very high.

• Wood, paper and ceramic are some insulators.

• Insulators are used in insulating electrical equipment for safety purposes.

Q 7. What do you understand by shielding of wires in an automotive electrical?

Answer: A shielded cable or screened cable is an electrical cable of one or more insulated conductors enclosed by a common conductive layer. The shield may be composed of braided strands of copper (or other metal, such as aluminium), a non-braided spiral winding of copper tape, or a layer of conducting polymer. Usually this shield is covered with a jacket. The use of shielded cables in security systems provides some protection from power frequency and radio frequency interference, reducing the number of false alarms being generated.

Q 8. What do you understand by capacitors? Name any four applications of capacitors in an automotive electrical.

Answer: A capacitor is a device that stores electrical energy in an electric field. It is a passive electronic component with two terminals.

Application of capacitors:

- Energy storage.
- Digital memory.
- Pulsed power and weapons.
- Power conditioning.
- Power factor correction.
- Suppression and coupling.
- Signal coupling.
- Decoupling.
- High-pass and low-pass filters.
- Noise suppression, spikes, and snubbers.
- Motor starters.
- Signal processing.
- Tuned circuits.
- Sensing.
- Oscillators.
- Producing light.

Section – C

03X03 = 09 Marks

Q 9. Explain the followings:

- a) Wires.
- b) Fuses.
- c) Relays.

Answer:

- a) **Wires:** A wire is a single, usually cylindrical, flexible strand or rod of metal. Wires are used to bear mechanical loads or electricity and telecommunications signals. Wire is commonly formed by drawing the metal through a hole in a die or draw plate. Wire gauges come in various standard sizes, as expressed in terms of a gauge number. The term wire is also used more loosely to refer to a bundle of such strands, as in "multistranded wire", which is more correctly termed a wire rope in mechanics, or a cable in electricity.
- b) **Fuses:** In electronics and electrical engineering, a fuse is an electrical safety device that operates to provide overcurrent protection of an electrical circuit. Its essential component is a metal wire or strip that melts when too much current flows through it, thereby interrupting the current. It is a sacrificial device; once a fuse has operated it is an open circuit, and it must be replaced or rewired, depending on type.
- c) **Relays:** Relays are switches that open and close circuits electromechanically or electronically. Relays control one electrical circuit by opening and closing contacts in another circuit. As relay diagrams show, when a relay contact is normally open (NO), there is an open contact when the relay is not energized. When a relay contact is Normally Closed (NC), there is a closed contact when the relay is not energized. In either case, applying electrical current to the contacts will change their state.

Q 10. Find out the missing units in the electrical circuit:

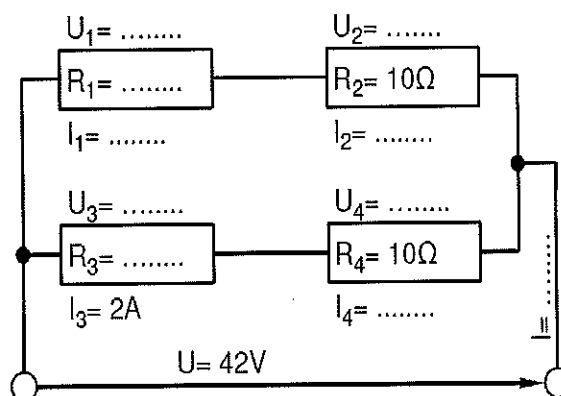

Answer:

- U₁ = 22V
- U₂ = 20V
- U₃ = 22V

- U₄ = 20V
- R₁ = 11Ω
- R₃ = 11 Ω

- I₁ = 2A
- I₂ = 2A
- I₄ = 2A

$I = 4A.$

Q 11.

- a) One cable is damaged on the insulation. A residual current of 0.5mA flows at a voltage of 28V. What is the resistance at the damaged area?

Answer:

$I = 0.5 \text{ mA}; \quad V = 28V; \quad R = ?$

w.k.t. $V = I.R$

So, $R = V/I = 28/0.5 \times 10^{-3} = 56k\Omega$

- b) Draw and calculate the missing units of the given circuit:

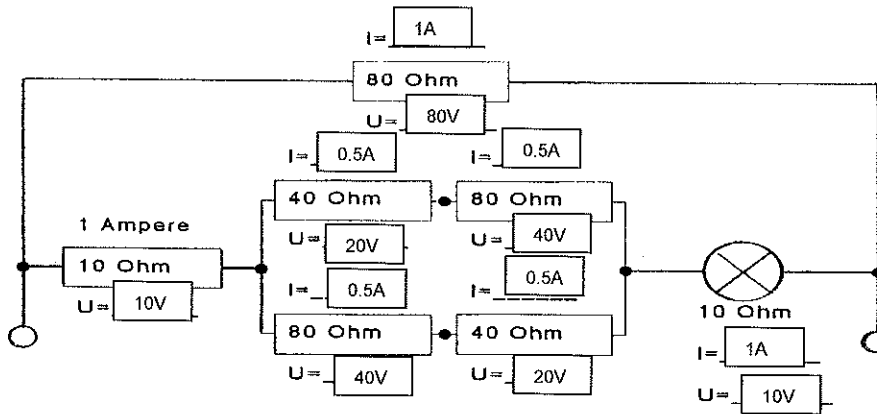



School of Automotive Skills
Session: 2019-20 (Summer Semester)
B. Voc. Program, 1st Semester,
1st In-Sem. Examination

Course Code: AUT1106

Time: 1 Hour

Course Name: Automotive Tools and Measurement

Max. Marks: 20

Instruction:

1. Answer all questions from "**Section-A**", each question carries 01 mark.
2. Answer all questions from "**Section-B**", each question carries 02 marks.
3. Answer all questions from "**Section-C**", each question carries 03 marks.

Section – A

Directions: Select any one correct answer from the given options: 05X01 = 05 Marks

- 1) Line composed of closely and evenly spaced short dashes in a drawing represents.....
 - a) Hidden edges
 - b) Hatching
 - c) Visible edges
 - d) Pitch circle of gears
- 2) In orthographic projections, the rays are assumed to:
 - a) Be parallel
 - b) diverge from the station point
 - c) converge from station point
 - d) None of these
- 3) A point 'P' is above horizontal plane (HP) and front of vertical plane (VP). The point is in:
 - a) Second quadrant
 - b) First quadrant
 - c) Third quadrant
 - d) Fourth quadrant
- 4) Which of the following represent reducing scale?
 - a) 1:2
 - b) 5:1
 - c) 2:1
 - d) 1:1
- 5)is the degree of looseness and tightness between two mating parts.
 - a) Clearance
 - b) Tolerance
 - c) Fit
 - d) Limits

Section – B

03X02 = 06 Marks

- 6) What do you mean by engineering drawing? Also write the standard size of drawing sheets A4, A3, A2, A1 & A0 as per BIS.
- 7) Draw the layout of drawing sheet with proper specifications and margin.
- 8) Write down the different types of lines and their applications.

Section – C

03X03 = 09 Marks

- 9) Discuss orthographic projection and also write the differences between first and third angle projection.
- 10) Explain the classification of tolerance.
- 11) Describe the different types of fits with the help of diagram.

[Handwritten signature]
11/9/19





School of Automotive Skills
Session: 2019-20 (Summer Semester)
B. Voc. Program, 1st Semester,
1st In-Sem. Examination

Course Code: AUT1106

Time: 1 Hour

Course Name: Automotive Tools and Measurement

Max. Marks: 20

Instruction:

1. Answer all questions from “**Section-A**”, each question carries 01 mark.
2. Answer all questions from “**Section-B**”, each question carries 02 marks.
3. Answer all questions from “**Section-C**”, each question carries 03 marks.

Section – A

Directions: Select any one correct answer from the given options: 05X01 = 05 Marks

- 1) Line composed of closely and evenly spaced short dashes in a drawing represents.....
a) **Hidden edges** c) Visible edges
b) Hatching d) Pitch circle of gears
- 2) In orthographic projections, the rays are assumed to:
a) **Be parallel** c) converge from station point
b) diverge from the station point d) None of these
- 3) A point ‘P’ is above horizontal plane (HP) and front of vertical plane (VP). The point is in:
a) Second quadrant c) Third quadrant
b) **First quadrant** d) Fourth quadrant
- 4) Which of the following represent reducing scale?
a) **1:2** c) 2:1
b) 5:1 d) 1:1
- 5)is the degree of looseness and tightness between two mating parts.
a) Clearance c) **Fit**
b) Tolerance d) Limits

Section – B

03X02 = 06 Marks

- 6) What do you mean by engineering drawing? Also write the standard size of drawing sheets A4, A3, A2, A1 & A0 as per BIS.

Ans: - Engineering Drawing is the Graphical means of expressing technical details without the barrier of language.

Table 1.2 Standard Sizes of Drawing sheets as per BIS

Designation	Size (mm)
A0	841 x 1189
A1	594 x 841
A2	420 x 594
A3	297 x 420
A4	210 x 297

7) Draw the layout of drawing sheet with proper specifications and margin.

Ans: -

Any engineering drawing has to follow a standard format. The drawing sheet consist of drawing space, title block and sufficient margins.

A typical drawing sheet consist of the following:

- Borders, Filling margin, Grid reference system, Title box, Form – shape of the part.
- Example; Rectangle, Circle, etc.

Details of material.

Dimensions – sizes of forms and shapes.

- Tolerances – acceptable deviation from dimensions.
- Surface finish and treatment required.
- Other General information – notes.

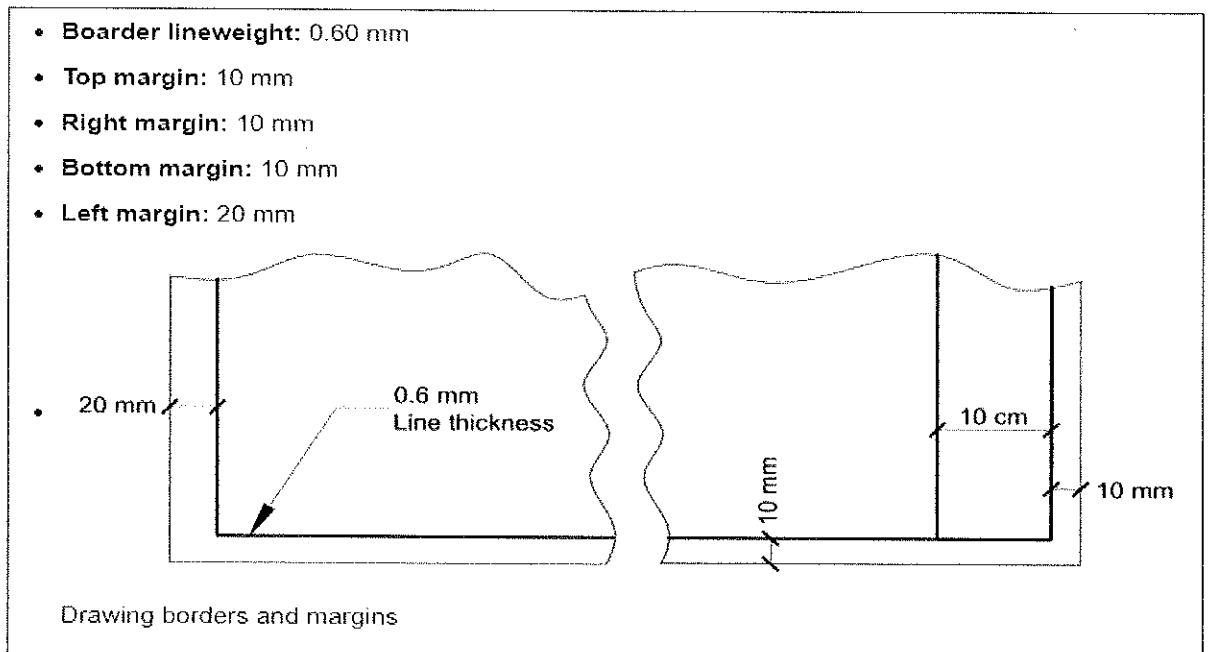







Title Block (Sample)				
10	NAME:	UPES DEHRADUN		
10	ROLL NO.:			20
10	SEM. & SEC.:	LINES & LETTERING		10
10	SUB. DATE:		SHEET NO.: 01	10
10	GRADE:		CHECKED BY:	10
	50	50	50	
NOTES: All the dimensions are in millimeters.				



BHARTIYA SKILL DEVELOPMENT UNIVERSITY

8) Write down the different types of lines and their applications.

Ans: -

Illustration	Application
Thick 	Outlines, visible edges, surface boundaries of objects, margin lines
Continuous thin 	Dimension lines, extension lines, section lines leader or pointer lines, construction lines, boarder lines
Continuous thin wavy 	Short break lines or irregular boundary lines – drawn freehand
Continuous thin with zig-zag 	Long break lines
Short dashes, gap 1, length 3 mm 	Invisible or interior surfaces
Short dashes 	Center lines, locus lines Alternate long and short dashes in a proportion of 6:1,
Long chain thick at end and thin elsewhere 	Cutting plane lines

Section – C

03X03 = 09 Marks

9) Discuss orthographic projection and also write the differences between first and third angle projection.

Ans: -

- Orthographic projection is a Parallel Projection Technique in which the plane of projection is perpendicular to the parallel line of sight.
- Orthographic Projection is a method of representing a three dimensional object on paper using several two dimensional views.
- It is the international language of Engineers and Designers
- There are two ways of drawing in orthographic First Angle and Third Angle.

First angle projection	Third-angle projection
Object is kept in the first quadrant.	Object is assumed to be kept in the third quadrant.
Object lies between observer and the plane of projection.	Plane of projection lies between the observer and the object.
The plane of projection is assumed to be non-transparent.	The plane of projection is assumed to be transparent.
Front (elevation) view is drawn above the XY line	Front (elevation) view is drawn below the XY line
Top (plan) view is drawn below the XY line	Top (plan) view is drawn above the XY line
Left view is projected on the right plane and vice versa	Left view is projected on the left plane itself.
Followed in India, European countries	Followed in USA

10) Explain the classification of tolerance.

Ans: -

Tolerance can be defined as the magnitude of permissible variation of a dimension or other measured value from the specified value.

Classification of Tolerance:

Tolerance can be classified under the following categories:

A. Dimensional Tolerance

1. Unilateral tolerance
2. Bilateral tolerance
3. Compound tolerance

B. Geometric tolerance

- **Dimensional Tolerance can be define as:**
- **Unilateral Tolerance:** When the tolerance distribution is only on one side of the basic size, it is known as unilateral tolerance. In other words, tolerance limits lie wholly on one side of the basic size, either above or below it.
- **Bilateral Tolerance:** When the tolerance distribution lies on either side of the basic size, it is known as bilateral tolerance. In other words, the dimension of the part is allowed to vary on both sides of the basic size but may not be necessarily equally disposed about it.

Geometric Tolerance: Geometric Dimensioning and Tolerance (GD & T) is a system for defining and communicating engineering tolerances. It uses a symbolic language on engineering drawings and computer generated three dimensional solid models that explicitly describes nominal geometry and its allowable variation.

11) Describe the different types of fits with the help of diagram.

Ans:

It is the degree of looseness and tightness between two mating parts to perform a definite function.

- The relationship between the two mating parts that are to be assembled, that is, the hole and the shaft, with respect to the difference in their dimensions before assembly is called a fit.
- An ideal fit is required for proper functioning of the mating parts. Three basic types of fits can be identified, depending on the actual limits of the hole or shaft:
 - a. Clearance fit
 - b. Transition fit
 - c. Interference fit

Clearance fit: The largest permissible diameter of the shaft is smaller than the diameter of the smallest hole.

- In case of clearance fit, the difference between the sizes is always positive.

Interference fit: The minimum permissible diameter of the shaft exceeds the maximum allowable diameter of the hole.

- This type of fit always provides interference. Interference fit is a form of a tight fit. Tools are required for the precise assembly of two parts with an interference fit.
- In an interference fit, the difference between the sizes is always negative.

Transition fit: Occurs when two tolerance mating parts are sometimes an interference fit and sometimes a clearance fit when assembled.

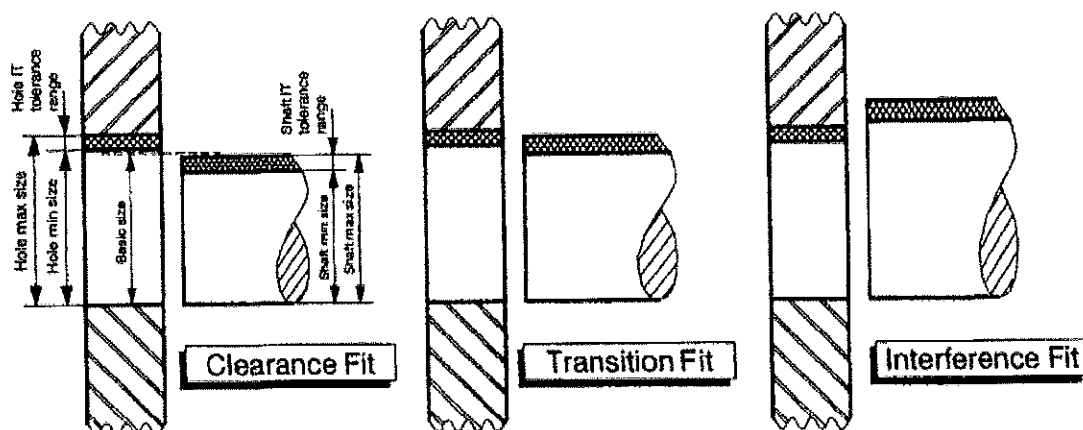

Figure 5.9 Typical clearance, transition and interference fits for a shaft in a hole

