

**BHARTIYA SKILL DEVELOPMENT UNIVERSITY****School of Automotive Skills****Session: 2019-20 (Summer Semester)****B. Voc. Program, 1<sup>st</sup> Semester,****2<sup>nd</sup> In-Sem. Examination****Course Code: AUT1101****Time: 1 Hour****Course Name: Automotive Power Train, Chassis & Suspension****Max. Marks: 20 Marks****Instruction:**

1. Answer all questions from section A, each question carries one mark
2. Answer all question from section B, each question carries two mark.
3. Answer all question from section C, each question carries three mark.

**Section – A****Directions:** Select any one correct answer from the given options: 05X01 = 05 Marks

- 1) The transmission system transmits.....from engine to wheel.  
a) Speed  
b) Power  
c) Current  
d) Gear ratio
- 2) Which of the following is not a part of the transmission system?  
a) Clutch  
b) Axles  
c) Wheels  
d) Gear Box
- 3) The motion of the cam is transferred to the valves through...  
a) Piston  
b) Rocker arm  
c) Camshaft pulley  
d) Valve stem
- 4) The torque available at the contact between driving wheels and road is known as...  
a) Brake-effort  
b) Tractive-effort  
c) Clutch effort  
d) None of the above
- 5) If the engine coolant mix with engine oil, then it engine oil ....  
a) Appears milky  
b) Becomes foamy  
c) Appears black  
d) All of the above

**Section – B**

03X02 = 06 Marks

- 6) Draw PV diagram of an otto cycle with neat sketch.
- 7) What are the differences between otto cycle & diesel cycle? (Any four)
- 8) What are the components of air intake system? Also draw a layout of air intake system.



## BHARTIYA SKILL DEVELOPMENT UNIVERSITY

**Section – C**

**03X03 = 09 Marks**

- 9) Explain major components of an exhaust system.
- 10) Explain the working of turbocharger.
- 11) Explain the working of 2 stroke engine with the help of a diagram.

**BHARTIYA SKILL DEVELOPMENT UNIVERSITY**

School of Automotive Skills

Session: 2019-20 (Summer Semester)

B. Voc. Program, 1<sup>st</sup> Semester,2<sup>nd</sup> In-Sem. Examination

Course Code: AUT1101

Time: 1 Hour

Course Name: Automotive Power Train, Chassis &amp; Suspension

Max. Marks: 20 Marks

**Instruction:**

1. Answer all questions from section A, each question carries one mark
2. Answer all question from section B, each question carries two mark.
3. Answer all question from section C, each question carries three mark.

**Section – A****Directions:** Select any one correct answer from the given options: 05X01 = 05 Marks

- 1) The transmission system transmits.....from engine to wheel.  
a) Speed  
b) **Power**  
c) Current  
d) Gear ratio
- 2) Which of the following is not a part of the transmission system?  
a) Clutch  
b) Axles  
c) **Wheels**  
d) Gear Box
- 3) The motion of the cam is transferred to the valves through...  
a) Piston  
b) **Rocker arm**  
c) Camshaft pulley  
d) Valve stem
- 4) The torque available at the contact between driving wheels and road is known as...  
a) Brake-effort  
b) **Tractive-effort**  
c) Clutch effort  
d) None of the above
- 5) If the engine coolant mix with engine oil, then it engine oil ....  
a) **Appears milky**  
b) Becomes foamy  
c) Appears black  
d) All of the above

**Section – B**

03X02 = 06 Marks

## BHARTIYA SKILL DEVELOPMENT UNIVERSITY

6) Draw PV diagram of an otto cycle with neat sketch. Ans.

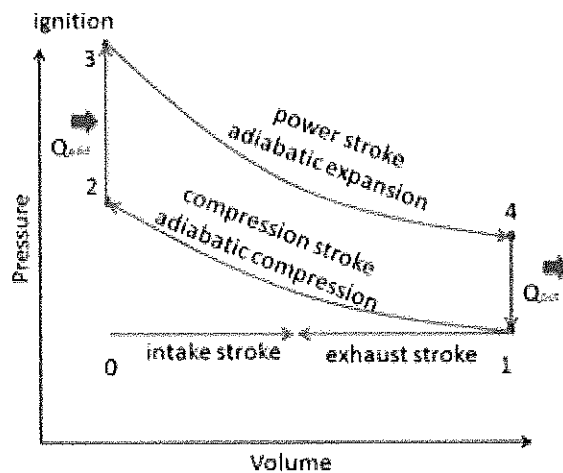

7) What are the differences between otto cycle & diesel cycle? (Any four)

Ans.

S.No.	Otto Cycle	Diesel Cycle
1.	Otto cycle is given by the Nicolas Otto in 1876.	It was given by Dr. Rudolph Diesel in 1897.
2.	Heat addition takes place at constant volume.	Heat addition takes place at constant pressure.
3.	Petrol engines work on this cycle.	Diesel engines work on this cycle.
4.	Compression ratio is less. It is 7:1 to 10:1.	Compression ratio is more. It is 11:1 to 22:1.
5.	Efficiency is less.	Efficiency is more.
6.	Spark plug is used	Fuel Injector is used.

8) Write are the components of air intake system? Also draw a layout of air intake system.

Ans. Components of an exhaust system

AIR FILTER

TURBO CHARGER

INTERCOOLER

AIR FILTER CLOGGING INDICATOR

HOSES

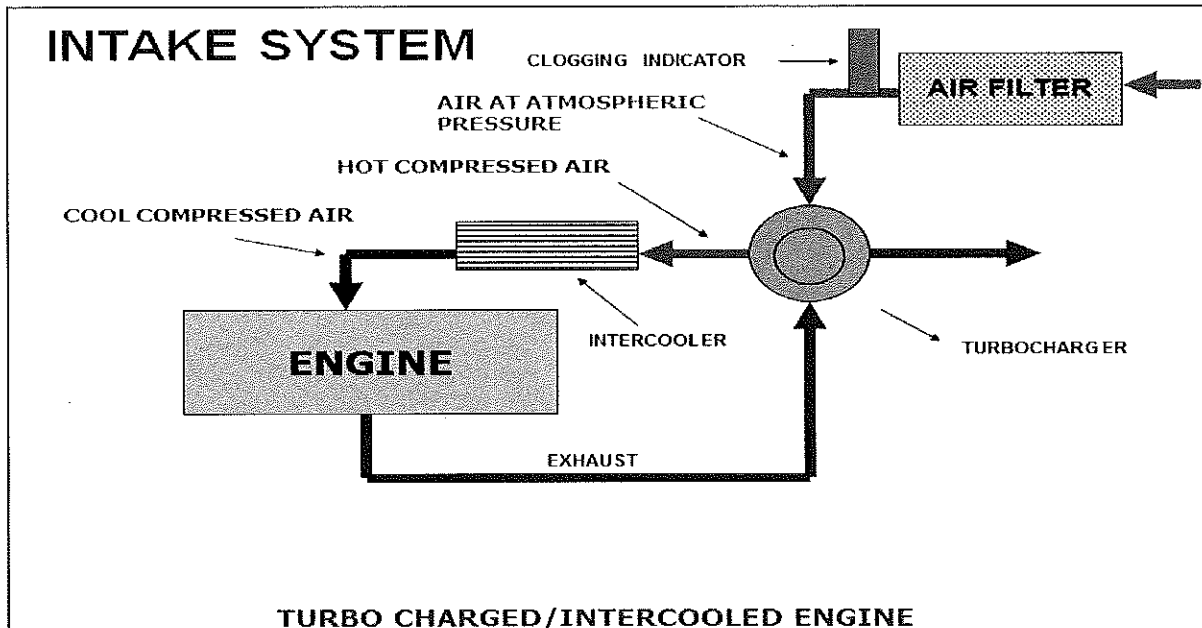

**Section – C**

03X03 = 09 Marks

9) Explain major components of an exhaust system.

Ans.

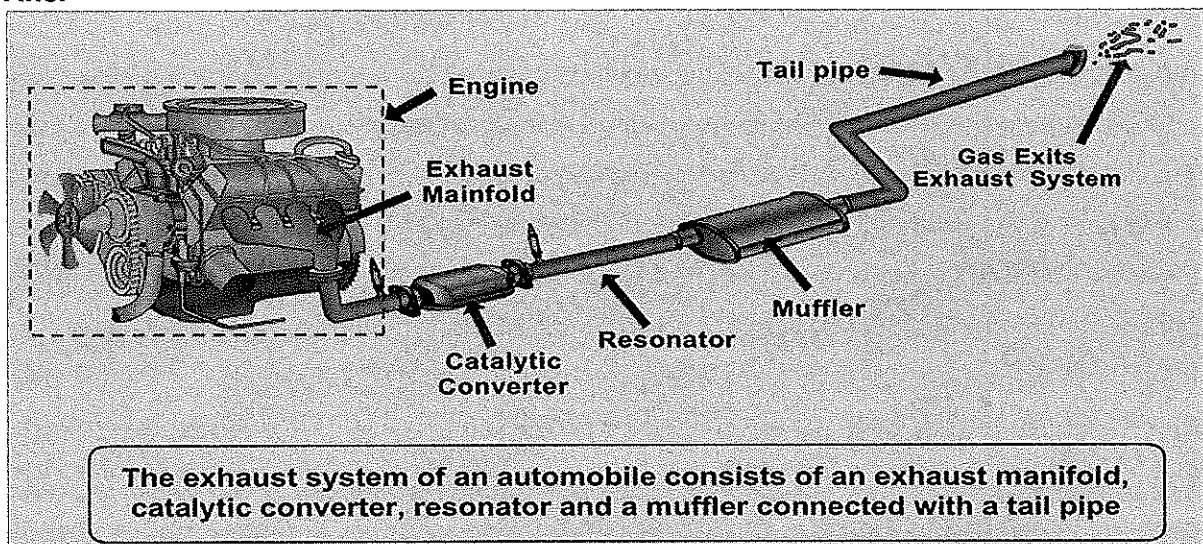

10) Explain the working of turbocharger.

Ans. The turbo charger utilizes the wasted heat energy in the exhaust system, to run a compressor which compresses the intake air. Compressed intake air has more density and hence more fuel can be injected increasing the power of the engine.

## BHARTIYA SKILL DEVELOPMENT UNIVERSITY

Turbo charging is an ideal way to increase the engine power without increasing the engine size.

11) Explain the working of 2 stroke engine with the help of a diagram.

Ans.

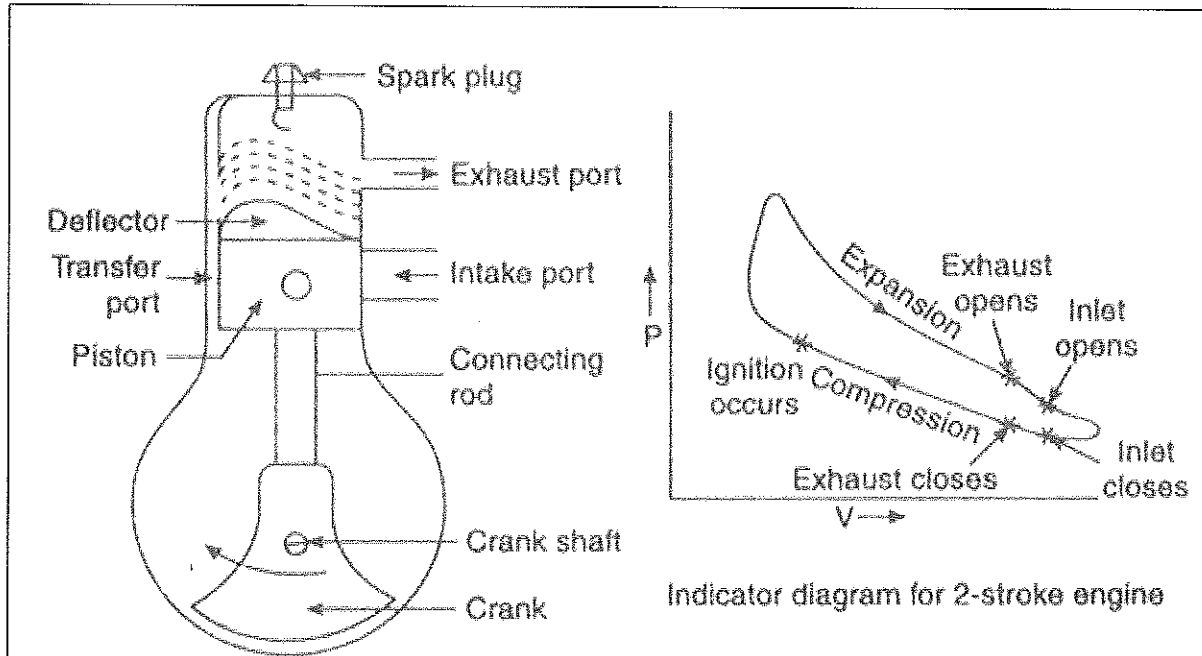

The working principle of 2-Stroke petrol engine is discussed below: -

**1) 1<sup>st</sup> Stroke:** To start with let us assume the piston to be at its B.D.C. position. The arrangement of the ports is such that the piston performs two jobs simultaneously.

As the piston starts rising from its B.D.C. position it closes the transfer port and the exhaust port. The charge (mixture, of the air and petrol) which is already there in the cylinder, as the result of the previous running of the engine is compressed at the same time with the upward movement of the piston vacuum is created in the crank case (which is gas tight). As soon as the inlet port is uncovered; the fresh charge is sucked in the crank case. The charging is continued until the crank case and the space in the cylinder beneath the piston is filled with the charge. As the end of third stroke, the piston reached the T.D.C. position.

**2) 2<sup>nd</sup> Stroke:** Slightly before the completion of the compression stroke, the compressed charge is ignited by means of a spark produced at the spark plug.

pressure is exerted on the crank of the piston due to the combustion of the piston is pushed in the downward direction producing some useful power. The downward movement of the piston will first close the inlet port and then it will compress the charge already sucked in the crank case.

Just the end of power stroke, the piston uncovered the exhaust port and the transfer port simultaneously the expanded gases start escaping through the exhaust port and the same



## **BHARTIYA SKILL DEVELOPMENT UNIVERSITY**

time the fresh charge which is already compressed in the crank case, rushed into the cylinder through the transfer port and thus the cycle is repeated again.

The fresh charge coming into the cylinder also helps in exhausting the burnt gases out of the cylinder through the exhaust port. This is known as scavenging.





# BHARTIYA SKILL DEVELOPMENT UNIVERSITY

School of Automotive Skills  
Session: 2019-20 (Summer Semester)  
B. Voc. Program, 1<sup>st</sup> Semester  
2<sup>nd</sup> In-Sem. Examination

Course Code: AUT1102

Course Name: Automotive Wheel Care and Steering System

Time: 1 hour

Max. Marks: 20

## Instruction:

1. Answer all questions from section – A, each question carries one mark.
2. Answer all questions from section – B, each question carries two marks.
3. Answer all questions from section – C, each question carries three marks.

### Section – A

(5X1 marks)

**Q 1.** The collection of components, linkages, etc. which allows any vehicle to follow the desired course is known as:

- A. Suspension System
- B. Steering System
- C. Braking System
- D. All of the above

**Q 2.** Which of the following is **not** a function of Steering system?

- A. To achieve angular motion of front wheels
- B. Provide perfect rolling motion to the wheels
- C. Distribute the power in wheels while turning
- D. Straight ahead recovery after turning

**Q 3.** The device intended primarily for connecting the steering wheel to the steering mechanism or transferring the driver's input torque from the steering wheel is known as:

- A. Universal joint
- B. Worm and wheel
- C. Steering column
- D. Steering bush

**Q 4.** The Hydraulic Power Steering is based on:

- A. Newton's laws of motion
- B. Bernoulli's theorem
- C. Pascal's law
- D. None of the Above

**Q 5.** In EPS, the rotating torque according to the required power-assist calculations is provided by:

- A. Reduction Gear
- B. Electric Motor
- C. Hydraulic Pump
- D. ECU

### Section – B

(3X2 marks)

**Q 6.** Write a short note on the material used for manufacturing tyres.

**Q 7.** Briefly explain the principle on which HPS works.



## BHARTIYA SKILL DEVELOPMENT UNIVERSITY

**Q 8.** What is the major difference between HPS, EPS and EPHS?

**Section – C**

**(3X3 marks)**

**Q 9.** How the tyres are classified? Briefly explain each of them.

**Q 10.** Explain the working of an Electric Power Steering System.

**Q 11.** Write a short note on:

- a. Run Flat Tyres
- b. Homologation



# BHARTIYA SKILL DEVELOPMENT UNIVERSITY

School of Automotive Skills  
Session: 2019-20 (Summer Semester)  
B. Voc. Program, 1<sup>st</sup> Semester  
2<sup>nd</sup> In-Sem. Examination

Course Code: AUT1102

Course Name: Automotive Wheel Care and Steering System

Time: 1 hour

Max. Marks: 20

## Instruction:

1. Answer all questions from section – A, each question carries one mark.
2. Answer all questions from section – B, each question carries two marks.
3. Answer all questions from section – C, each question carries three marks.

### Section – A

(5X1 marks)

**Q 1.** The collection of components, linkages, etc. which allows any vehicle to follow the desired course is known as:

- A. Suspension System
- B. **Steering System**
- C. Braking System
- D. All of the above

**Q 2.** Which of the following is **not** a function of Steering system?

- A. To achieve angular motion of front wheels
- B. Provide perfect rolling motion to the wheels
- C. **Distribute the power in wheels while turning**
- D. Straight ahead recovery after turning

**Q 3.** The device intended primarily for connecting the steering wheel to the steering mechanism or transferring the driver's input torque from the steering wheel is known as:

- A. Universal joint
- B. Worm and wheel
- C. **Steering column**
- D. Steering bush

**Q 4.** The Hydraulic Power Steering is based on:

- A. Newton's laws of motion
- B. Bernoulli's theorem
- C. **Pascal's law**
- D. None of the Above

**Q 5.** In EPS, the rotating torque according to the required power-assist calculations is provided by:

- A. Reduction Gear
- B. **Electric Motor**
- C. Hydraulic Pump
- D. ECU

### Section – B

(3X2 marks)

**Q 6.** Write a short note on the material used for manufacturing tyres.

- The **materials** of modern pneumatic **tyres** are synthetic rubber, natural rubber, **fabric** and wire, along with carbon black and other chemical compounds.

## BHARTIYA SKILL DEVELOPMENT UNIVERSITY

- They consist of a tread and a body. The tread provides traction while the body provides containment for a quantity of compressed air.

**Q 7.** Briefly explain the principle on which HPS works.

In this system fluid pressure from the pump is used to push against a piston. When the wheel is turned, pressure flows to one side and the piston moves. The piston is attached to the **steering** gears. Hydraulic pressure does the **work**, and the driver controls the direction by turning the **steering** wheel.

**Q 8.** What is the major difference between HPS, EPS and EPHS?

HPS- driving force is provided by hydraulic pump operated by engine

EPHS- driving force is provided by hydraulic pump operated by electric motor

EPS- driving force is provided by electric motor

### Section – C

(3X3 marks)

**Q 9.** How the tyres are classified? Briefly explain each of them.

1. **Summer Tyres:**

Summer tyres are designed to work best during the warmer summer months. They are created with a specific tread pattern for optimal performance on both dry and wet roads when the air temperature is above +7°C.

2. **Winter tyres:**

look very similar to summer tyres but are specially developed to provide additional driving performance in winter conditions. It is a common misconception that winter tyres are only for driving in the snow.

Winter tyres are designed to work best in conditions below +7°C, so even in wet and icy conditions, you'll benefit from their superior grip and handling.

3. **All season tyres**

essentially combine elements of summer tyres and winter tyres.

To create a tyre that has benefits of both so that they can be used all-year round, giving drivers peace of mind whatever the weather throws at them.

While all season car tyres are not likely to match the performance of specialist summer or winter tyres during these respective seasons, they provide a good all-round mix of strengths.

**Q 10.** Explain the working of an Electric Power Steering System.

The reduction gear is press fitted onto a set of splines on the pinion shaft and delivers the assist to the rack gear instead of pushing on the rack gear as in a hydraulic system. The steering gear itself is a manual rack with an electric motor mounted on the steering column or the rack. The components are:

- Steering Wheel
- Steering Column & Shaft
- Universal Joint
- Steering Gear Box
- Electric motor
- Linkage (Tie Rod)
- Reduction Gear
- ECU (**Electronic Control Unit**)
- Torque sensor

**Q 11.** Write a short note on:

a. Run Flat Tyres

Run flat tyres are designed in such a way to remain operational in the event of a puncture or a severe loss of air pressure allowing you to make it to safety, be that so

## BHARTIYA SKILL DEVELOPMENT UNIVERSITY

you can return home or to your nearest tyre fitter. Run flat tyres also reduce the risk of tyre blow outs which could be dangerous and a risk to the safety of the driver and other road users if they occur at speed. Run flat tyres have much thicker, reinforced sidewalls which means they can be driven on for a short time after picking up a puncture. The tyre can temporarily maintain its shape and strength even in the event of a total loss of air pressure.

b. Homologation

Many of the world's top car manufacturers including BMW, Mercedes, and Audi have designated markings and the same letters and symbols are used by all tyre manufacturers to show that the tyre has been specifically designed for that vehicle.

Symbol	Manufacturer
A0	Audi
J	Jaguar
FO	Ford
G	Volkswagen
A	Toyota





# BHARTIYA SKILL DEVELOPMENT UNIVERSITY

Registration No.: .....

**School of Automotive Skills**  
**Session: 2019-20 (Summer Semester)**  
**B. Voc. Program, 1<sup>st</sup> Semester**  
**2<sup>nd</sup> In-Sem. Examination**

**Course Code : AUT1103**

**Time : 1 Hour**

**Course Name: Automotive Body Repair**

**Max. Marks : 20**

**Instructions:**

1. Answer all questions from section A, each question carries one mark.
2. Answer all questions from section B, each question carries two marks.
3. Answer all questions from section C, each question carries three marks.

**Section – A**

05X01 = 05 Marks

1. Which of the following gas mixtures is not used in Tungsten inert gas arc welding (TIG)?
  - a. Argon-Helium.
  - b. Argon-Nitrogen.
  - c. Argon-Hydrogen.
  - d. Argon-Carbon dioxide.
2. The heat generated (H) in resistance welding is expressed by
  - a.  $I^2RT$
  - b.  $IR^2T$
  - c.  $IRT^2$
  - d.  $2IRT$
3. What type of joint is shown in the figure below?

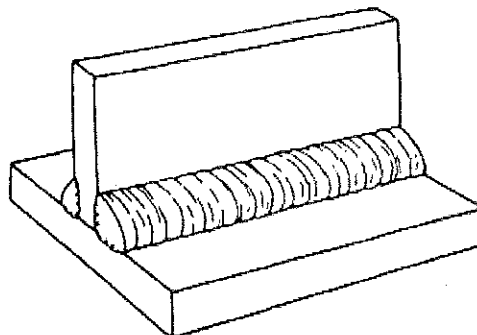

- a. Butt Joint.
- b. I Joint.
- c. Corner Joint.
- d. T Joint.



# BHARTIYA SKILL DEVELOPMENT UNIVERSITY

Registration No.: .....

4. Which of the following is not an inert gas?
  - a. Argon.
  - b. CO<sub>2</sub>
  - c. Helium.
  - d. Neon.
  
5. Working Temperature range in MMAW is close to
  - a. 500 °C.
  - b. 2000 °C.
  - c. 4000 °C.
  - d. 1000 °C.

## Section – B

03X02 = 06 Marks

1. Define welding and mention machine parameters need to be set before welding.
2. What are the advantages of MIG/ MAG welding over MMAW?
3. What is the function of coating over core wire in electrodes?

## Section – C

03X03 = 09 Marks

1. Explain the process of MIG/ MAG welding with a neat diagram.
2. Differentiate between Soldering and Brazing.
3. What is the working principle of Plasma Cutting?



# BHARTIYA SKILL DEVELOPMENT UNIVERSITY

Registration No.: .....

**School of Automotive Skills**  
**Session: 2019-20 (Summer Semester)**  
**B. Voc. Program, 1<sup>st</sup> Semester**  
**2<sup>nd</sup> In-Sem. Examination**

**Course Code : AUT1103**

**Time : 1 Hour**

**Course Name: Automotive Body Repair**

**Max. Marks : 20**

**Instructions:**

1. Answer all questions from section A, each question carries one mark.
2. Answer all questions from section B, each question carries two marks.
3. Answer all questions from section C, each question carries three marks.

**Section – A**

05X01 = 05 Marks

1. Which of the following gas mixtures is not used in Tungsten inert gas arc welding (TIG)?
  - a. Argon-Helium.
  - b. Argon-Nitrogen.
  - c. Argon-Hydrogen.
  - d. Argon-Carbon dioxide.

**Ans. b. Argon-Nitrogen**

2. The heat generated (H) in resistance welding is expressed by
  - a.  $I^2RT$
  - b.  $IR^2T$
  - c.  $IRT^2$
  - d.  $2IRT$

**Ans. a.  $I^2RT$**

3. What type of joint is shown in the figure below?

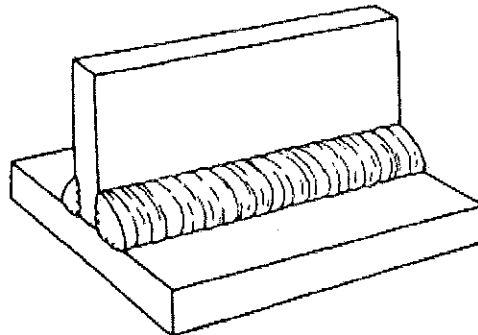

- a. Butt Joint.
- b. I Joint.



# BHARTIYA SKILL DEVELOPMENT UNIVERSITY

Registration No.: .....

- c. Corner Joint.
- d. T Joint.

**Ans. d. T Joint**

4. Which of the following is not an inert gas?
- a. Argon.
  - b. CO<sub>2</sub>
  - c. Helium.
  - d. Neon.

**Ans. b. CO<sub>2</sub>**

5. Working Temperature range in MMAW is close to
- a. 500 °C.
  - b. 2000 °C.
  - c. 4000 °C.
  - d. 1000 °C.

**Ans. c. 4000°C**

## Section – B

03X02 = 06 Marks

1. Define welding and mention machine parameters need to be set before welding.

Ans. **Welding** is a fabrication or sculptural process that joins materials, usually metals or thermoplastics, by using high heat to melt the parts together and allowing them to cool causing fusion. Welding is distinct from lower temperature metal-joining techniques such as brazing and soldering, which do not melt the base metal.

The four important parameters are the welding current, wire electrode extension, welding voltage and arc travel speed.

2. What are the advantages of MIG/ MAG welding over MMAW?

Ans. Advantages of MIG/ MAG welding over MMAW are as follows:

- 1. High quality welds can be produced much faster.
- 2. Since flux is not used, there is no chance for the entrapment of slag in the weld metal resulting in high quality welds.
- 3. The gas shield protects the arc so that there is very little loss of alloying elements. Only minor weld spatter is produced.
- 4. MIG welding is versatile and can be used with a wide variety of metals and alloys.
- 5. The MIG process can be operated several ways, including semi and fully automatic.

3. What is the function of coating over core wire in electrodes?

Ans. The function of coating over core wire in electrodes is as follows:

- 1. Provide a protective atmosphere (a gas shield around the arc).
- 2. Stabilize the arc.
- 3. Act as a flux to remove impurities from the molten metal.

4. Provide a protective slag coating to accumulate impurities, prevent oxidation, and slow the cooling of the weld metal.
5. Reduce weld-metal spatter and increase the efficiency of deposition.
6. Add alloying elements.
7. Affect arc penetration (the depth of melting in the work piece).
8. Influence the shape of the weld bead.
9. Add additional filler metal.

**Section – C**

03X03 = 09 Marks

1. Explain the process of MIG/ MAG welding with a neat diagram.

Ans.

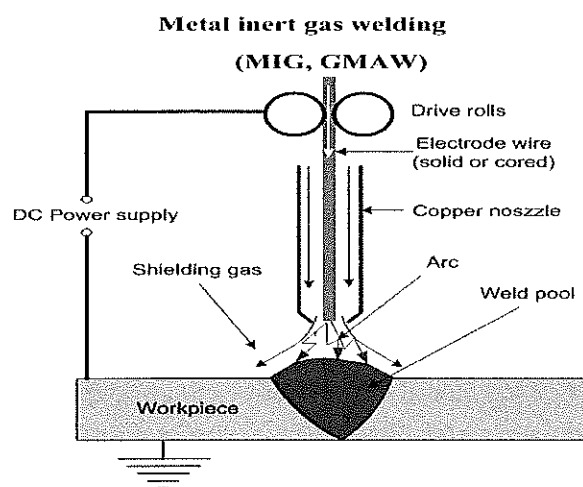

Metal inert gas welding takes its name from the use of inert gases such as argon, helium and mixture of the two gases. MIG welding is an arc welding process in which a continuous solid wire electrode is fed through a welding gun and into the weld pool, joining two base materials together. The process is semi- automatic because the electrode and gas are automatically fed through a welding the gun at a user defined speed when the operator pulls down the trigger.

2. Differentiate between Soldering and Brazing.

Ans.

S.No.	Soldering	Brazing
1	It is used in electrical industries to joint capacitor, resistor, wire etc. to the electronic plate.	It is used in mechanical industries to joint different metals.
2	soldering is done temperature below 400°C	Brazing is done at temperature above 450°C but below the critical temperature of metal.
3	These joint are weaker than brazing joints.	It forms stronger joints.



## BHARTIYA SKILL DEVELOPMENT UNIVERSITY

Registration No.: .....

4	In soldering an alloy of lead and tin is used known as solder.	In brazing an alloy of copper and zinc is used as a filler metal.
5	It is a cheaper process.	It is a costly process.
6	Soldering does not need to preheat the base metal	This process needs preheating of base metal.
7	It is used to join electronic components.	It is used in automotive industries and pipe fitting.
8	This process is very flexible and easy to automate.	It is not easy for automation except automation is done at automotive industries.

### 3. What is the working principle of Plasma Cutting?

Ans. Plasma arc cutting is a process resulting from ionizing a column of gas (argon, nitrogen, helium, air, hydrogen or their mixture) with extreme heat of an electric arc. The ionized gas along with the arc is forced through a very small nozzle orifice, resulting into a plasma stream of high velocity (up to 600 m/sec) and high temperature (up to 20000K). When this high speed is reached, high temperature plasma stream and electric arc strike the work piece, and ion in the plasma recombine into gas atoms and liberate a great amount of latent heat. This heat melts the work piece, vaporizes part of the material and the balance is blasted away in the form of molten metal through the heat.



# BHARTIYA SKILL DEVELOPMENT UNIVERSITY

Registration No.: .....

School of Automotive Skills

Session: 2019-20 (Summer Semester)

B. Voc. Program, 1<sup>st</sup> Semester,

2<sup>nd</sup> In-Sem. Examination

Course Code: AUT1104

Time: 1 Hour

Course Name: Automotive Spray Painting

Max. Marks: 20

**Instruction:**

1. Answer all questions from section A, each question carries one mark.
2. Answer all questions from section B, each question carries two mark.
3. Answer all questions from section C, each question carries three mark.

**Section – A**

05X01 = 05 Marks

Q-1. Which one of the following is not a common layer between OEM & refinish paint?

- |                                 |                |
|---------------------------------|----------------|
| a. Primer surfacer / under coat | c. Base coat   |
| b. Clear coat                   | d. Body filler |

Q-2. Putty is used for .....

- |                                    |                               |
|------------------------------------|-------------------------------|
| a. Filling big dents               | c. Increasing paint thickness |
| b. Filling small dents and scratch | d. Applying instead of primer |

Q-3. Paint mixing machine should run.....

- |                              |                               |
|------------------------------|-------------------------------|
| a. Twice in a day for 15min. | c. Twice in a day for 5min.   |
| b. Twice in a week for 5min. | d. Twice in a week for 15min. |

Q-4. What is the mixing ratio of body filler and hardener?

- |                 |                      |
|-----------------|----------------------|
| a. 100gms: 2gms | c. 100gms: 20gms     |
| b. 100gms: 2 mg | d. None of the above |

Q-5. Which of the following components provide color to the paint.

- |              |             |
|--------------|-------------|
| a. Binder    | c. Pigments |
| b. Additives | d. Solvents |

**Section – B**

03X02 = 06 Marks

Q-6. Write short note on spray guns.

Q-7. Write do's and don't for paint booth.

Q-8. Brief about all kind of safety equipment used in paint shop.

**Section – C**

03X03 = 09 Marks

Q-9. Explain different types of sanding disc.

Q-10. Explain the various types of filters in paint booth.

Q-11. Explain primer application process and its advantages.





**School of Automotive Skills**  
**Session: 2019-20 (Summer Semester)**  
**B. Voc. Program, 1<sup>st</sup> Semester,**  
**2<sup>nd</sup> In-Sem. Examination**

**Course Code: AUT1104**

**Time: 1 Hour**

**Course Name: Automotive Spray Painting**

**Max. Marks: 20**

**Instruction:**

1. Answer all questions from section A, each question carries one mark.
2. Answer all questions from section B, each question carries two mark.
3. Answer all questions from section C, each question carries three mark.

**Section – A**

05X01 = 05 Marks

Q-1. Which one of the following is not a common layer between OEM & refinish paint?

- |                                 |                       |
|---------------------------------|-----------------------|
| a. Primer surfacer / under coat | c. Base coat          |
| b. Clear coat                   | d. <b>Body filler</b> |

Q-2. Putty is used for .....

- |   |                               |
|---|-------------------------------|
| a. Filling big dents                      | c. Increasing paint thickness |
| b. <b>Filling small dents and scratch</b> | d. Applying instead of primer |

Q-3. Paint mixing machine should run.....

- |                                     |                               |
|-------------------------------------|-------------------------------|
| a. <b>Twice in a day for 15min.</b> | c. Twice in a day for 5min.   |
| b. Twice in a week for 5min.        | d. Twice in a week for 15min. |

Q-4. What is the mixing ratio of body filler and hardener?

- |                        |                      |
|------------------------|----------------------|
| a. <b>100gms: 2gms</b> | c. 100gms: 20gms     |
| b. 100gms: 2 mg        | d. None of the above |

Q-5. Which of the following components provide color to the paint.

- |              |                    |
|--------------|--------------------|
| a. Binder    | c. <b>Pigments</b> |
| b. Additives | d. Solvents        |

**Section – B**

03X02 = 06 Marks

Q-6. Write short note on spray guns.

Ans: - A spray gun is a piece of equipment which you use to spray paint under pressure onto a surface.

The spray gun is the most popular type of spray application equipment use

- An spray gun is a tool which uses compressed air to atomise paint and to apply it to a surface.
- Air and material enter the gun through separate passages and are mixed at the air cap in a controlled pattern.

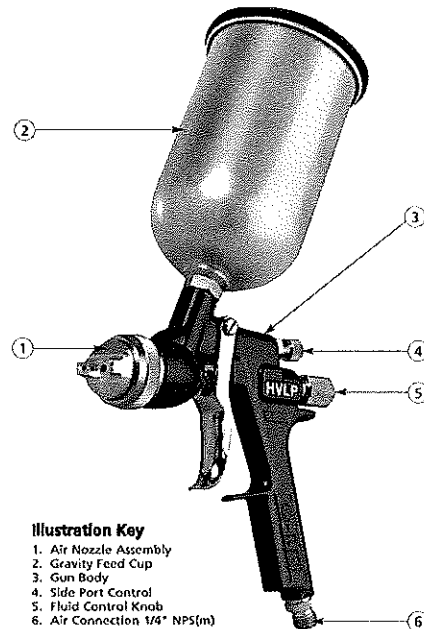

There are primarily four types of gun:-

1. Cup spray guns
2. Air spray guns
3. Airless spray guns
4. HVLP spray guns

Q-7. Write do's and don't for paint booth.

Ans: **Do's:**

1. While switch on the paint booth, please ensure that voltage is above 380volts.
2. Keep the paint booth and its surroundings clean.
3. Sanding is not advisable in surrounding of paint booth.
4. Open the main door only for vehicle entry.
5. For all other movements use only service door.
6. Please insure the vehicle and technician dress must be dust free.
7. Switch off the main supply after completion of work.

**Don'ts:**

1. Don't store paints and accessories inside paint booth.
2. Don't use any cotton waste inside paint booth.
3. Don't spray the paint/test the spray gun on floor filter.
4. Don't throw the west paint material on the floor filter.
5. Don't use compressed air for cleaning the paint booth walls and floor.
6. Don't allow sparks inside the paint booth.
7. Don't open the main door during painting.



Q-8. Brief about all kind of safety equipment used in paint shop.

Ans: Safety Equipment:

1. Hand gloves.
2. Safety shoes
3. Mask and respirator
4. Safety glasses
5. Protective Clothing.
6. Ear plugs.

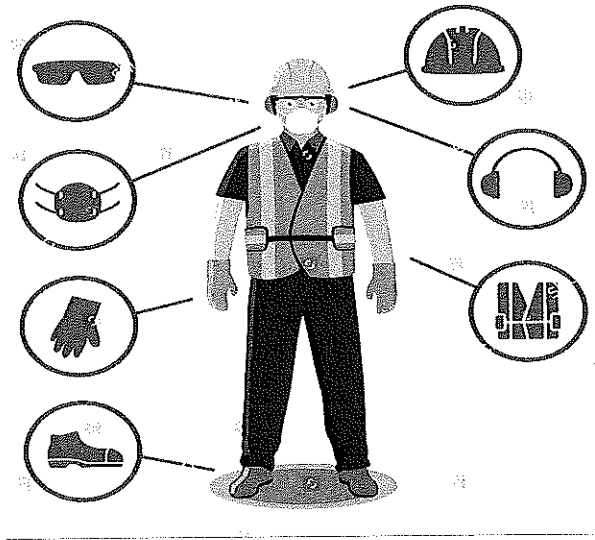

## Section – C

03X03 = 09 Marks

Q-9. Explain different types of sanding disc.

Ans: P- 80-Grit

In contrast to sandpapers in the 32 to 40-grit range, 80-grit sandpaper is not terribly rough on the surface of vehicle panels. As such, 80-grit can be applied to the hood, roof or door panels of a car or van without leaving rough streaks. However, light streaking will still be present if you apply heavy force. Therefore, the use of 80-grit sandpaper on a vehicle will usually need to be followed by a smooth-out sanding with a higher-grit sandpaper. Ultimately, 80-grit is best used on vehicles that need considerable sanding in select areas, but without the roughness of lower-grit options.

### 320-Grit

At this point along the wet sandpaper grit chart, the options are ideal for smooth buffering as well as the removal of thick paint. With a 320-grit piece of sandpaper, paint should come off the vehicle with evenly applied strokes of a disc. By the time you work a 320-grit through the paint, the shiny, silvery luster of the metal should come glaring to the surface. Thanks to the strength of 320-grit sandpaper, it's a good option for cars or vans that have been treated with enamel or other hard coats. A perfect example of how 320-grit sandpaper can work is when you want to turn a blue van red. Before you apply the new paint job, you'll want to sand away



## BHARTIYA SKILL DEVELOPMENT UNIVERSITY

the older blue coats. With 320-grit, the blue should come off smoothly and easily. Once all of the panels have been stripped, the surfaces should be smooth enough for a primer coat of the new paint. Alternately, 320-grit could make it really easy to change out the paint on a single panel, such as a scratched door. As such, when people ask what grit sandpaper to use when painting a car, 320-grit is a good choice for large automobiles with thick coats.

### **400-Grit**

When it comes to finishing, the most popular option is 400-grit sandpaper. Before the new coat of paint is applied, 400-grit paper makes prepping smooth and easy. If there are any rough areas spotted along the surface or edges of a given panel, 400-grit could be used to smooth the metal out in a way that lower grits might be incapable of. The best thing about 400-grit sandpaper is that, despite its strength, it's fine enough to handle challenges along an auto-body surface without roughing up the metal. When the question arises about what grit sandpaper is appropriate for a wet sanding primer, 400-grit is sometimes stressed as better for wet sanding than for dry sanding. The reasoning here is that, when dry, 400-grit tends to leave sand on the subject, which can be troublesome as far as finishing work is concerned. Therefore, while 400-grit is one of the most popular grits of sandpaper, it's often used exclusively for wet sanding. As such, 400-grit is one of the most widespread options on the wet sandpaper grit chart.

### **600-Grit**

When it comes to correcting errors in soft layers of paint, 600-grit sandpaper makes the task relatively easy. Likewise, if paint runs out before a panel has been fully covered, the edges of the paint can be sanded smooth with a wet 600. Basically, 600-grit sandpaper is a perfect option when you need to salvage the panels after a paint job has hit a snag. When you consider all the time and money that can slip down the drain when a vehicle-painting project doesn't go as planned, 600-grit sandpaper is a lifesaver because it reduces complications. For example, you might be painting a car with a unique color that has to be specially ordered, but end up with a bad passenger door or roof due to the paint running out when you're 93-percent finished. In an earlier set of circumstances, you might have needed to do the paintjob over again, yet still be at risk of running out along another part of the vehicle. With 600-grit sandpaper, it needn't be as costly or time-consuming, because the raw edges of an unfinished paint job can be sanded back for a recoat and will therefore be ready by the time a new supply of the same paint arrives.

Q-10. Explain the various types of filters in paint booth.

Ans: Air makeup filters come in multiple varieties such as pad, panel, cleanable aluminum and pocket and bag filters. ... This is the importance of intake filters; they provide clean, filtered air to the booth so your coating operation is free of foreign particles that can contaminate your paint job.



## **Pre-Filters**

Pre-filters are made from ultra-fibre glass. Hence it is easy to handle. The offered paint booth filter is extensively used in industrial and commercial applications. Pre-filters are placed outside the booth towards the right or left side. They can be used to filter incoming air or outgoing or exhausted air.

## **Ceiling Filters**

As the name implies, ceiling filters are placed on the roof of the booth. A ceiling filter lasts for maximum 8 to 9 months. It is used to collect dust from the roof side. These filters can be customised. The sizes we offer are:

### **AVAILABLE SIZES:**

- 1.0 Meter x 20 Meter (Rolls)
- 1.5 Meter x 20 Meter(Rolls)
- 2.0 Meter x 20 Meter(Rolls)

## **Paint Stop Filters/Floor Filters**

Paint stop filters are to be placed inside the booth, on the floor and left, right and back side of the booth. The duration is maximum 200 hours. Such filters are not suitable for oil based paint. The available sizes are:

### **AVAILABLE SIZES:**

- 0.8 Meter x 20 Meter (Rolls)
- 1.0 Meter x 20 Meter (Rolls)
- 1.5 Meter x 20 Meter(Rolls)
- 2.0 Meter x 20 Meter(Rolls)

Q-11. Explain primer application process and its advantages.

Ans:

### **Step 1: Remove Dirt: -**

Mechanical cleaning may include something as ordinary as wiping dust from the surface with a clean cloth. When firmly attached metal scale or heavy rust must be removed, vigorous cleaning methods are required. Abrasive removal using a sanding belt or disk or manually applied abrasive pad can be effective. Equally beneficial may be the use of a wire brush or wheel to remove tenaciously held rust. When very large areas are to be cleaned, it often is efficient to use sand or grit blasting with grit suspended in a high-pressure air or water blast. The grits used in this technique can include sand, steel shot, glass beads, aluminum oxides and soft-cutting organic materials such as ground walnut hulls or ground corncobs. Rather than being carried by an air or water "blast," grit materials may also be vigorously "hurled"



## BHARTIYA SKILL DEVELOPMENT UNIVERSITY

from a rotating wheel or moving belt at the object to be cleaned. With grit cleaning or blasting, care must be exercised to avoid leaving grit particles embedded in the surface as these can cause poor paint adhesion and possible early corrosion under the paint film. When recirculated grit is employed, provision

### Cleaning the Surface 3

should be made for separating and removing accumulated debris. Mechanical cleaning may be coupled with liquid cleaners using cushioned plastic wool pads, which have the advantage of not loading up and becoming "blinded" and dirt-embedded. Like sanding media, the pads are available in a range of physical sizes and grit sizes from coarse to fine.

### Step 2: **Sand the Car:** -

Sand the paint either to the bare metal, the original primer, or at least sufficiently for the new paint to adhere. Dry sand using 180-grit sandpaper to remove rust or surface damage before moving on to a 320-grit paper to remove your previous 180-grit scratches.

Step 3: Let your Car Dry: - After cleaning sanding and again cleaning dry the car or panel for some time so the degreaser can be dry perfectly.

Step 4: Priming

Step 5: Sand Car again



Registration No.: .....

## BHARTIYA SKILL DEVELOPMENT UNIVERSITY

School of Automotive Skills  
Session 2019-20, Summer Semester  
B. Voc. Program, 1<sup>st</sup> Semester,  
2<sup>nd</sup> In-Sem. Examination

Course Code: AUT1105

Time: 1 Hour

Course Name: Automotive Electrical Fundamentals & Comfort System

Max. Marks: 20

### Instruction:

1. Answer all questions from section – A, each question carries one mark.
2. Answer all questions from section – B, each question carries two marks.
3. Answer all questions from section – C, each question carries three marks.

### Section – A

05x01 = 05 Marks

Q 1. OBD used in scanning the sensor faults in an Automotive vehicle stands for....

- |                           |                         |
|---------------------------|-------------------------|
| A. Over Board Diagnostic. | C. On Board Display.    |
| B. On Board Data.         | D. On Board Diagnostic. |

Q 2. Mixed-Signal Circuits in an Automotive electronics is also known as.....

- |                       |                              |
|-----------------------|------------------------------|
| A. Combined Circuits. | C. Hybrid Circuits.          |
| B. Joint Circuits.    | D. Series-Parallel Circuits. |

Q 3. Which one of the following component is not a part of an electronic component?

- A. Inductor.
- B. Relay.
- C. Wire.
- D. Diode.

Q 4. An ..... actuator is powered by a motor that converts electrical energy into mechanical energy.

- |               |                |
|---------------|----------------|
| A. Electric.  | C. Pneumatic.  |
| B. Hydraulic. | D. Mechanical. |

Q 5. What type of specification is used to rate a transducer?

- A. Transmitting Range.
- B. Receiving Range.
- C. Dynamic Range.
- D. All of the above.

### Section – B

03X02 = 06 Marks

- Q 6. Differentiate between actuators and sensors.
- Q 7. What are the functions of an ECU in an automotive vehicle?
- Q 8. What do you understand by insulators? Name any four applications of insulators in an automotive electrical.

### Section – C

03X03 = 09 Marks

- Q 9. Explain the function of an OBD-II Scanning Tool. Name any three parameters of an OBD-II Scanning Tool used in an Automotive Workshop.
- Q 10. Write a short note on:
- Electrostatic Effects.
  - Ohm's Law.
  - Multimeter.
- Q 11. Solve the following problems:
- One cable is damaged on the insulation. A residual current of 5.5A flows at a voltage of 48V. What is the resistance at the damaged area?
  - If 500 $\mu$ A flow at 250mV, then what will be the resistance in the circuit?
  - Define the use of Oxygen / Lambda Sensor in an automotive vehicle.



# BHARTIYA SKILL DEVELOPMENT UNIVERSITY

**School of Automotive Skills**  
**Session 2019-20, Summer Semester**  
**B. Voc. Program, 1<sup>st</sup> Semester,**  
**2<sup>nd</sup> In-Sem. Examination**

**Course Code: AUT1105**

**Course Name: Automotive Electrical Fundamentals & Comfort System**

### Section – A

05x01 = 05 Marks

Q 1. OBD in scanning the sensor faults in an Automotive vehicle stands for....

**Answer:** D. On Board Diagnostic.

Q 2. Mixed-Signal Circuits in an Automotive electronics is also known as.....

**Answer:** C. Hybrid Circuits.

Q 3. Which one of the component is not a part of an electronic component?

**Answer:** C. Wire.

Q 4. An ..... actuator is powered by a motor that converts electrical energy into mechanical energy.

**Answer:** A. Electric.

Q 5. What type of specification is used to rate a transducer?

**Answer:** C. Dynamic Range.

### Section – B

03X02 = 06 Marks

Q 6. Differentiate between actuators and sensors.

**Answer:**

**Difference between actuators and sensors**

Actuators	Sensors
<ul style="list-style-type: none"> <li>• A component of a machine that is responsible for moving and controlling mechanism.</li> </ul>	<ul style="list-style-type: none"> <li>• A device that detects events or changes in the environment and sends that information to other electronic devices.</li> </ul>

- Connected to the output ports of the system.

- Connected to the input ports of the system.

- Helps to control the environment or physical changes.

- Helps to monitor the changes in the environment.

- Output is a movement.

- Output is an electrical signal.

- Example – electric motors, stepper motors, comb drives, hydraulic cylinders, etc.

- Example – image sensor, bio-sensor, motion sensor, chemical sensor, etc.

Q 7. What are the functions of an ECU in an automotive vehicle?

**Answer:**

The main function of an ECU or Engine Control Unit is the controlling of series of function of actuators on an internal combustion engine and ensuring the excellent engine performance. The Engine Control Unit is also called Power train control unit.

Functioning of an ECU:

1. Controlling the air-fuel mixture.
2. Controlling the ignition timing.
3. Controlling the idle speed and variable valve timing.
4. ECU also increases the torque and BHP.

Q 8. What do you understand by insulators? Name any four applications of insulators in an automotive electrical.

**Answer:**

Insulators are the materials or substances which resist or don't allow the current to flow through them. They are mostly solid in nature and are finding use in a variety of systems. They do not allow the flow of heat as well. The property which makes insulators different from conductors is its resistivity.

Application of insulators:

1. Thermal Insulators, disallow heat to move from one place to another. We use them in making thermoplastic bottles, in fireproofing ceilings and walls.
2. Sound Insulators help in controlling noise level, as they are good in absorbance of sound. Therefore, we use them in buildings, conference halls, and buildings to make them noise-free
3. Electrical Insulators hinder the flow of electron or passage of current through them. We use them extensively in circuit boards, high-voltage systems and also in coating electric wire and cables.

## Section – C

03X03 = 09 Marks

Q 9. Explain the function of an OBD-II Scanning Tool. Name any three parameters of OBD-II Scanning Tool in an Automotive Workshop.

**Answer:**

On-board diagnostics (OBD) is an automotive term referring to a vehicle's self-diagnostic and reporting capability. OBD systems give the vehicle owner or repair technician access to the status of the various vehicle subsystems.

Parameters:

1. It is used to read all diagnostics data from the car.
2. It has Mobile device-based tools and analysis, PC-based scan tools and analysis platforms, Data Loggers, Emission Testing, Driver's supplementary vehicle instrumentation, vehicle telematics.
3. Used to monitor real-time data like:
  - a. Engine temperature.
  - b. Fuel rate.
  - c. O2 sensor voltage.
  - d. Battery voltage level.
  - e. Time your engine has been running, etc.

Q 10. Write a short note on:

- a) Electrostatic Effects.
- b) Ohm's Law.
- c) Multimeter.

**Answer:**

- a) Electrostatic effects: Electrostatics is a branch of physics that studies electric charges at rest. Since classical physics, it has been known that some materials such as amber attract lightweight particles after rubbing. The Greek word for amber, or electron, was the source of the word 'electricity'. Electrostatic phenomena arise from the forces that electric charges exert on each other. Such forces are described by Coulomb's law. Even though electrostatically induced forces seem to be rather weak, some electrostatic forces such as the one between an electron and a proton, that together make up a hydrogen atom, is about 36 orders of magnitude stronger than the gravitational force acting between them.
- b) Ohm's Law: Ohm's law states that the current through a conductor between two points is directly proportional to the voltage across the two points. Introducing the constant of proportionality, the resistance, one arrives at the usual mathematical equation that describes this relationship:

$$I=V / R$$

- c) Multimeter: A multimeter or a multimeter, also known as a VOM (volt-ohm-milliammeter), is an electronic measuring instrument that combines several measurement

functions in one unit. A typical multimeter can measure voltage, current, and resistance. Analog multimeters use a micro-ammeter with a moving pointer to display readings. Digital multimeters (DMM, DVOM) have a numeric display, and may also show a graphical bar representing the measured value. Digital multimeters are now far more common due to their lower cost and greater precision, but analog multimeters are still preferable in some cases, for example when monitoring a rapidly varying value.

Q 11. Solve the following problems:

- a) One cable is damaged on the insulation. A residual current of 5.5A flows at a voltage of 48V. What is the resistance at the damaged area?

**Solution:**

Given: Voltage (V) = 48 V.

Current (I) = 5.5 A.

w.k.t. by Ohm's Law,

$$V = IR$$

$$48 = 5.5 \times R$$

$$\Rightarrow R = 48/5.5$$

$$\Rightarrow \mathbf{R = 8.73 \text{ Ohms}}$$
 (Resistance at the damaged area of the cable).

- b) If 500 $\mu$ A flow at 250mV, then what will be the resistance in the circuit?

**Solution:**

Given: Voltage (V) = 250 mV = 250  $\times 10^{-3}$  V.

Current (I) = 500  $\mu$ A = 500  $\times 10^{-6}$  A.

w.k.t. by Ohm's Law,

$$V = IR$$

$$\Rightarrow R = 250 \times 10^{-3} / 500 \times 10^{-6}$$

$$\Rightarrow \mathbf{R = 500 \text{ Ohms}}$$
 (Resistance in the circuit).

- c) Define the use of Oxygen / Lambda Sensor in an automotive vehicle.

**Answer:**

Lambda sensors (also known as oxygen sensors) are devices fitted to petrol and diesel engines that measure the oxygen content of exhaust gases. The purpose of the sensor is to help the engine run as efficiently as possible while producing fewer emissions. The lambda sensor is positioned in the exhaust pipe and can detect rich and lean mixtures. The mechanism in most sensors involves a chemical reaction that generates a voltage. The engine's computer (ECU) looks at the voltage and adjusts the fuel injector output accordingly, so as to bring it closer to the stoichiometric ratio ( $\lambda$ ).

The lambda sensor must be hot enough (around 350°C) to generate a voltage signal. Modern vehicles are equipped with sensors that typically have 3 or 4 wires and a small heating element that aids in attaining the high temperature faster. The heating element also prevents the sensor from cooling down too much during a prolonged idle state, which would cause the system to revert to open loop.

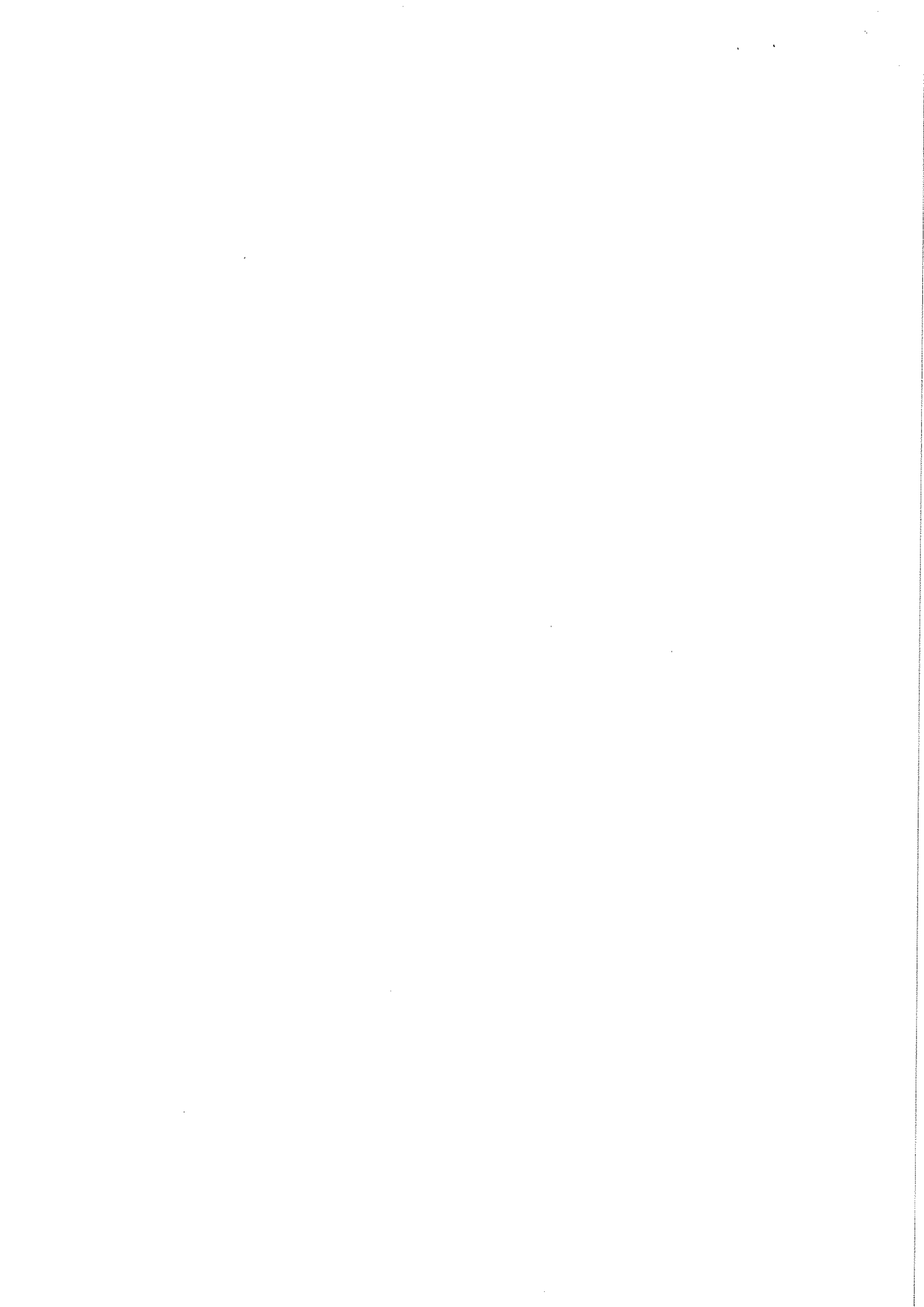



# BHARTIYA SKILL DEVELOPMENT UNIVERSITY

Registration No.: .....

**School of Automotive Skills**  
**Session: 2019-20 (Summer Semester)**  
**B. Voc. Program, 1<sup>st</sup> Semester,**  
**2<sup>nd</sup> In-Sem. Examination**

**Course Code: AUT1106**

**Time: 1 Hour**

**Course Name: Automotive Tools and Measurement**

**Max. Marks: 20**

**Instruction:**

1. Answer all questions from "**Section-A**", each question carries 01 mark.
2. Answer all questions from "**Section-B**", each question carries 02 marks.
3. Answer all questions from "**Section-C**", each question carries 03 marks.

**Section – A**

**Directions:** Select any one correct answer from the given options:

05X01 = 05 Marks

- 1) Steel ruler is used to:
  - a) Measure the simple component of an accuracy of 2 mm
  - b) Measure the simple component of an accuracy of 0.5 mm
  - c) Measure the angle of an accuracy 1°
  - d) Measure the bore of an accuracy 0.02 mm
- 2) Which of the following precaution is incorrect about using a micrometer?
  - a) Final movement is given by ratchet.
  - b) Thimble is turned till the measuring tip just touches the part to be measured.
  - c) Part to be measured is held in right and micrometer is in left hand for good results.
  - d) None of the above.
- 3) What is the zero error as shown in the figure below?

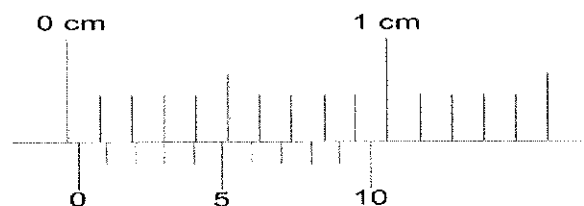

- a) -0.03 mm
  - b) -0.03 mm
  - c) 0.3 mm
  - d) 0.03 mm
- 4) What is the reading on micrometer as shown in the figure below?

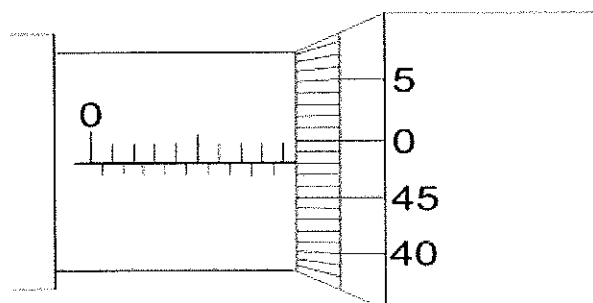

- a) 9.98 cm
- b) 9.48 cm
- c) 9.98 mm
- d) 9.48 mm

- 5) For which applications dial indicators are not used?
- a) Inspecting surfaces for flatness
  - b) Aligning work pieces
  - c) Inspecting shaft for roundness
  - d) Measuring bore spacing

**Section – B**

03X02 = 06 Marks

- 6) Define least count and also find the least count of Vernier Caliper if 39 mm of main scale divisions coincide with 20 divisions of auxiliary Vernier scale.

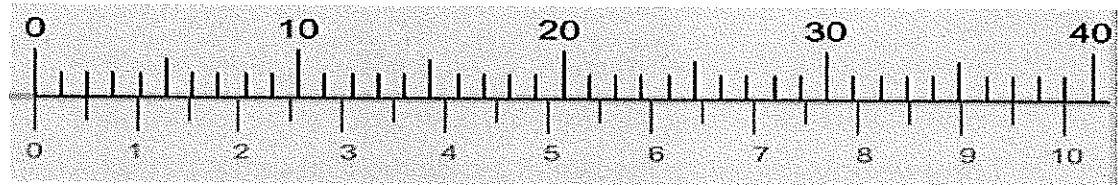

- 7) What are the different types of measurement errors in calipers? Explain any four in brief.
- 8) Write down the standard operating procedure for handling Vernier caliper.

**Section – C**

03X03 = 09 Marks

- 9) Explain the construction of Vernier caliper with the help of neat sketch.
- 10) Describe the applications of dial indicator.
- 11) Write short notes on:
- a) Plug and ring gauge
  - b) Feeler gauge
  - c) Taper ring gauge



**School of Automotive Skills**  
**Session: 2019-20 (Summer Semester)**  
**B. Voc. Program, 1<sup>st</sup> Semester,**  
**2<sup>nd</sup> In-Sem. Examination**

**Course Code:** AUT1106

**Time:** 1 Hour

**Course Name:** Automotive Tools and Measurement

**Max. Marks:** 20

**Instruction:**

1. Answer all questions from “**Section-A**”, each question carries 01 mark.
2. Answer all questions from “**Section-B**”, each question carries 02 marks.
3. Answer all questions from “**Section-C**”, each question carries 03 marks.

**Section – A**

**Directions:** Select any one correct answer from the given options:

05X01 = 05 Marks

- 1) Steel ruler is used to:
  - a) Measure the simple component of an accuracy of 2 mm
  - b) Measure the simple component of an accuracy of 0.5 mm
  - c) Measure the angle of an accuracy 1°
  - d) Measure the bore of an accuracy 0.02 mm

**Ans: - b)**

- 2) Which of the following precaution is incorrect about using a micrometer?
  - a) Final movement is given by ratchet
  - b) Thimble is turned till the measuring tip just touches the part to be measured
  - c) Part to be measured is held in right and micrometer is in left hand for good results
  - d) None of these

**Ans: - c)**

- 3) What is the zero error as shown in the figure below?

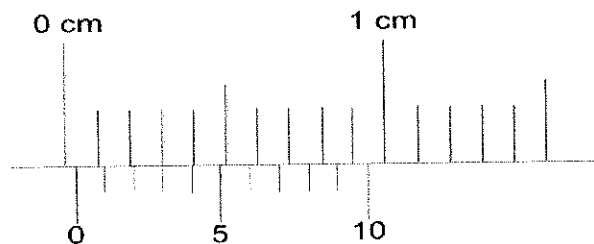

- |             |            |
|-------------|------------|
| a) -0.03 mm | c) 0.3 mm  |
| b) -0.03 mm | d) 0.03 mm |

**Ans: - d)**

- 4) What is the reading on micrometer as shown in the figure below?

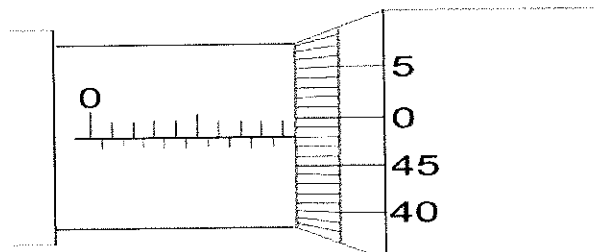



# BHARTIYA SKILL DEVELOPMENT UNIVERSITY

- a) 9.98 cm
- b) 9.48 cm

- c) 9.98 mm
- d) 9.48 mm

Ans: - d)

5) For which applications dial indicators are not used?

- a) Inspecting surfaces for flatness
- b) Aligning work pieces
- c) Inspecting shaft for roundness
- d) Measuring bore spacing

Ans: - d)

## Section – B

03X02 = 06 Marks

6) Define least count and also find the least count of Vernier Caliper if 39 mm of main scale divisions coincide with 20 divisions of auxiliary Vernier scale.

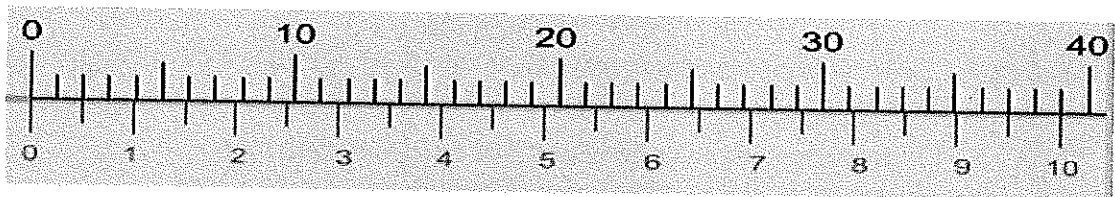

Ans: - The smallest value that can be measured by the measuring instruments is called least count.

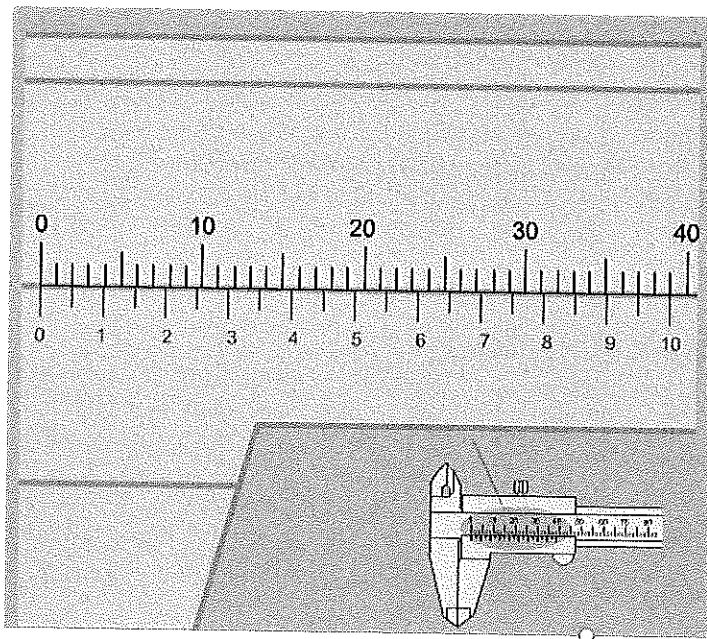

### Verniers

**Extended 20-Division Vernier**

39 mm of the main scale are divided into 20 equal parts on the auxiliary scale (vernier).

One vernier increment is therefore equal to 1.95 mm. It is thus, 0.05 mm ( $= 1/20$  mm), smaller than two main scale increments ( $= 2$  mm).

The result is a reading accuracy of  $1/20$  mm.

7) What are the different types of measurement errors in calipers? Explain any four in brief.

Ans: -

The different types of measurement errors in calipers are:

- Parallax error (observational error)
- Tilt error
- Cocking error
- Dirt or burs on the workpiece
- Environmental error
- Systematic error



## Parallax error (observational error)

As the name suggests, these types of errors occurs due to wrong observations or reading in the instruments. The wrong observations may be due to PARALLAX. In order to reduce the PARALLAX error highly accurate meters are needed: meters provided with mirror scales.

## Tilt error

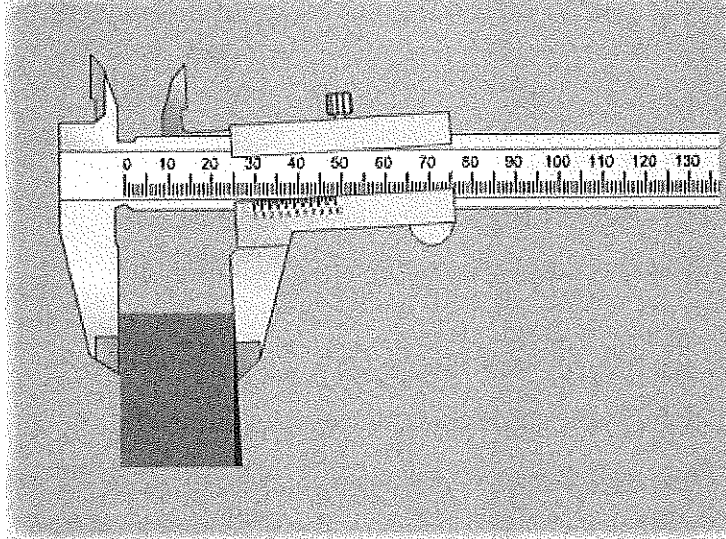

### Tilt Error

The movable jaw has too much play in the guide and tilts down when brought in contact with the work piece.

## Cocking error

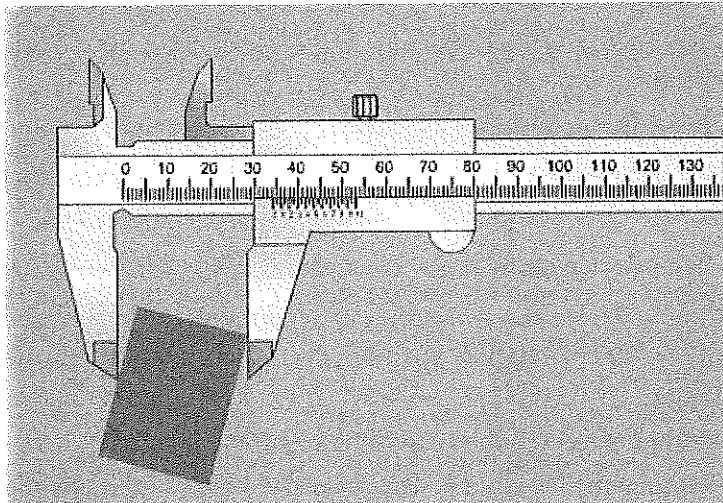

### Cocking

Either the work piece or the measurement tool is cocked during the measurement process.

## Dirt or burrs on the workpiece

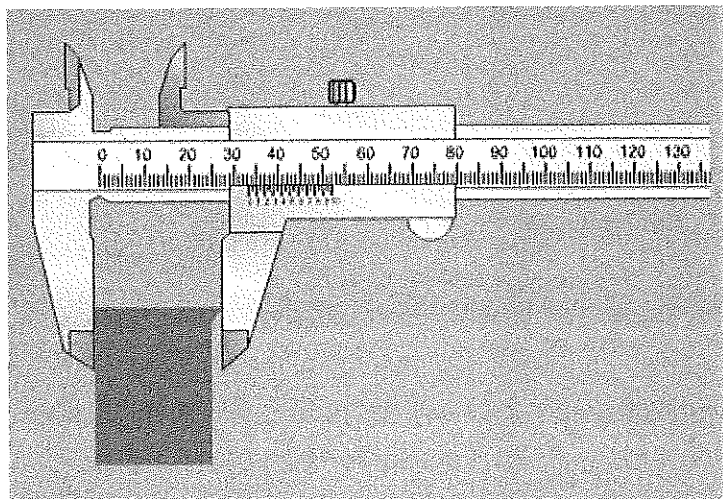

### Dirt or Burrs on the Work Piece

Due to dirt or a burr on the work piece, the measurement surfaces do not rest optimally on the work piece surfaces.



## Environmental error

The environmental errors occur due to some external conditions of the instrument. External conditions mainly include pressure, temperature, humidity or due to magnetic fields. In order to reduce the environmental errors

- Try to maintain the humidity and temperature constant in the laboratory by making some arrangements.
- Ensure that there shall not be any external electrostatic or magnetic field around the instrument.

## Systematic error

The Systematic errors that occur due to fault in the measuring device are known as systematic errors. Usually they are called as Zero Error – a positive or negative error.

- 8) Write down the standard operating procedures for handling Vernier caliper.

**Ans: -**

The standard operating procedures for handling Vernier caliper are:

1. First, determine the least count of Vernier caliper or measuring instruments.
2. Now, bring the movable jaw in close contact with the fixed jaw and find the zero error. Do this three times and record the values. If there is no zero error, then record 'zero error nil'.
3. Ensure that the work piece is free from dust, burs, etc.
4. Open the jaws of the Vernier Caliper and place the sphere or cylinder between the two jaws and adjust the movable jaw, such that it gently grips the body without any undue pressure on it. That done, tighten the screw attached to the Vernier scale.
5. Note the position of the zero mark of the Vernier scale on the main scale. Record the main scale reading just before the zero mark of the Vernier scale. This reading (N) is called main scale reading (MSR).
6. Note the number (n) of the Vernier scale division which coincides with the division of the main scale.
7. You'll have to repeat steps 5 and after 6 rotating the body by 90° for measuring the diameter in a perpendicular direction.
8. Repeat steps 5 to 6 for three different positions and record the observations.
9. Now find total reading using the equation,  $TR = MSR + VSR = N + (n \times L.C)$  and apply the zero correction.
10. Take the mean of the different values of the diameter and show that in the result with the proper unit.

## Section – C

03X03 = 09 Marks

- 9) Explain the construction of Vernier caliper with the help of neat sketch.

**Ans: -**

It consists of two scales. Fixed scale is called as a main scale & it is calibrated on L-shaped frame, which carries a fixed jaw. The movable scale is called as Vernier scale & it slides over the main scale, which carries movable jaw. When the two measuring jaws are in



## BHARTIYA SKILL DEVELOPMENT UNIVERSITY

contact with each other, the scale should show zero reading. An adjustable screw is provided for fine adjustment of movable jaw. Also, a lock nut is provided to lock the sliding scale on main scale.

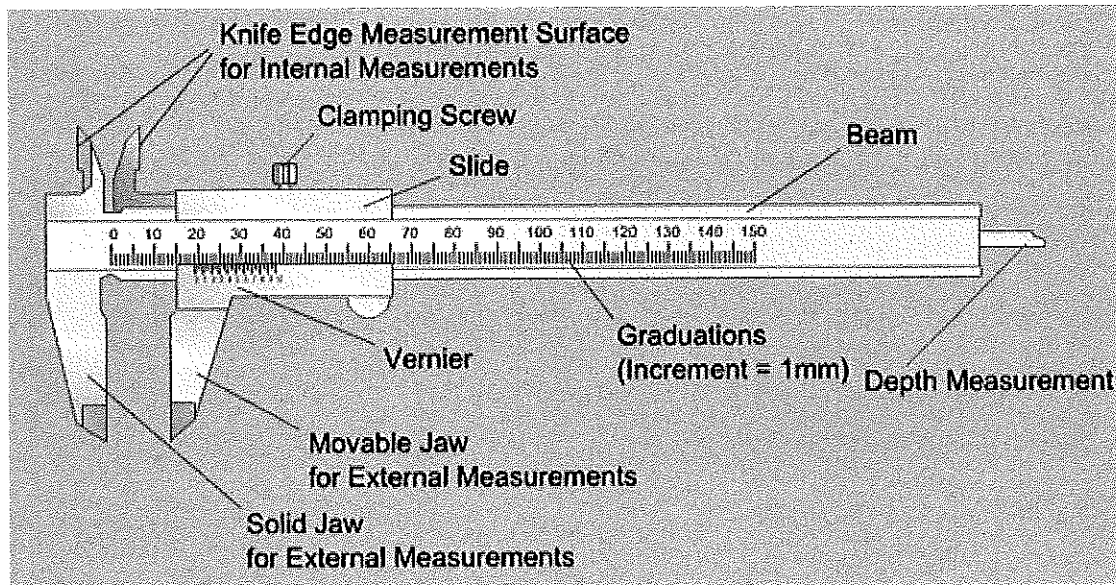

10) Describe the applications of dial indicator.

Ans: -

**Dial indicators** are one of the primary measuring tools used in precision engine building. They are typically used to measure deck clearances, crankshaft thrust and straightness, lifter travel and other measurements that involve the distance between two surfaces or small amounts of component travel.

The accuracy of the dial indicator is up to 0.001 mm are available.

It's used when;

- Surfaces are inspected for flatness
- Shaft are inspected for runout
- Backlash between two gear teeth.

11) Write short notes on:

a) Plug and ring gage

Ans: -

A **ring gauge**, or **ring gage**, is a cylindrical **ring** of a thermally stable material, often steel, whose inside diameter is finished to **gauge** tolerance and is used for checking the external diameter of a cylindrical object.

Plug gage is used to check the internal diameter of an object.

b) Feeler gage

A **feeler gauge** is a tool used to measure gap widths. **Feeler gauges** are mostly used in engineering to measure the clearance between two parts.

c) Taper ring gage



## Taper Ring Gage

Outside tapers are inspected with the taper ring gage.

Before inspection, the work piece is marked in the axial direction with a grease pencil or spotting blueing.

Then, the work piece and gage are mated together, rotated and separated again.

The mark must now be evenly smeared. The taper will not bear on places where the mark is not smeared.

