



**School of Automotive Skills**  
**Session: 2019-20 (Summer Semester)**  
**B. Voc. Program, 3<sup>rd</sup> Semester,**  
**2<sup>nd</sup> In-Sem. Examination**

**Course Code: AUT1301**

**Time: 1 Hour**

**Course Name: Automotive Power Train**

**Max. Marks: 20**

**Instruction: Attempt all questions.**

**Section A: Select the one correct option from the given options in the following questions.**

**Section – A**

05X01 = 05 Marks

Q-1. If the intake air temperature of I.C. engine increases, its efficiency will

- a. Increase
- b. Decrease
- c. Remain same
- d. Unpredicable

Q-2. The temperature of interior surface of cylinder wall in normal working operation is not allowed to exceed.

- a. 80°C
- b. 120°C
- c. 180°C
- d. 240°C

Q-3. The thermostatic valve opens and provides passage for the flow of water towards the radiator at approximately

- a. 90°C
- b. 220°C
- c. 150°C
- d. 180°C

Q-4. The essential components of battery ignition system are

- a. Battery
- b. Ballast resistor
- c. Ignition switch
- d. All of the mentioned

Q-5. The lead acid battery is used in \_\_\_\_\_ duty commercial vehicles.

- a. Heavy
- b. Light
- c. Large
- d. None of the mentioned

**Section – B**

03X02 = 06 Marks

Q-6. What are the special tools required for engine overhauling?

Q-7. Write short notes on

- A) Exhaust Gas Recirculation Valve
- B) Exhaust Valves



Q-8. Label the connecting rod diagram?

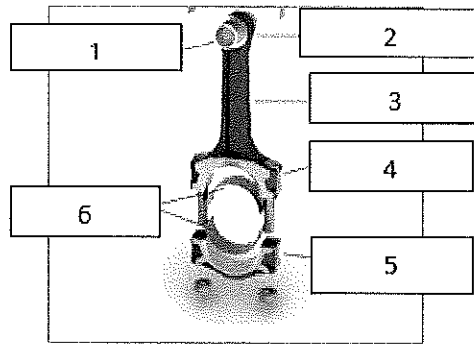

**Section – C**

03X03 = 09 Marks

Q-9. Explain gasoline fuel supply system components.

Q-10. Explain fuel efficiency test procedure.

Q-11. Explain engine cooling system.



**School of Automotive Skills**  
**Session: 2019-20 (Summer Semester)**  
**B. Voc. Program, 3<sup>rd</sup> Semester,**  
**2<sup>nd</sup> In-Sem. Examination**

**Course Code: AUT1301**

**Time: 1 Hour**

**Course Name: Automotive Power Train**

**Max. Marks: 20**

**Instruction: Attempt all questions.**

**Section A: Select the one correct option from the given options in the following questions.**

**Section – A**

05X01 = 05 Marks

Q-1. If the intake air temperature of I.C. engine increases, its efficiency will

- a. Increase
- b. Decrease
- c. Remain same
- d. Unpredicatable

Ans: (B) Decrease

Q-2. The temperature of interior surface of cylinder wall in normal working operation is not allowed to exceed.

- a. 80°C
- b. 120°C
- c. 180°C
- d. 240°C

Ans: (A) 180°C

Q-3. The thermostatic valve opens and provides passage for the flow of water towards the radiator at approximately

- a. 90°C
- b. 220°C
- c. 150°C
- d. 180°C

Ans: (A) 90°C

Q-4. The essential components of battery ignition system are

- a. Battery
- b. Ballast resistor
- c. Ignition switch
- d. All of the mentioned

Ans: (D) All the mentioned

Q-5. The lead acid battery is used in \_\_\_\_\_ duty commercial vehicles.

- a. Heavy
- b. Light
- c. Large
- d. None of the mentioned

Ans: (B) Light

## Section – B

03X02 = 06 Marks

Q-6. What are the special tools required for engine overhauling?

Ans:

Q-7. Write short notes on

A) Exhaust Gas Recirculation Valve

Ans:

In internal combustion engines, exhaust gas recirculation (EGR) is a nitrogen oxide (NO<sub>x</sub>) emissions reduction technique used in petrol/gasoline and diesel engines. EGR works by recirculating a portion of an engine's exhaust gas back to the engine cylinders.

B) Exhaust Valves:

Ans:

An exhaust valve is a valve that releases burned gases from a cylinder. The exhaust valve closes during the initial part of the induction stroke. The inlet valve usually opens a little before top dead center and the exhaust valve remains open a little after top dead center.

Q-8. Label the connecting rod diagram?

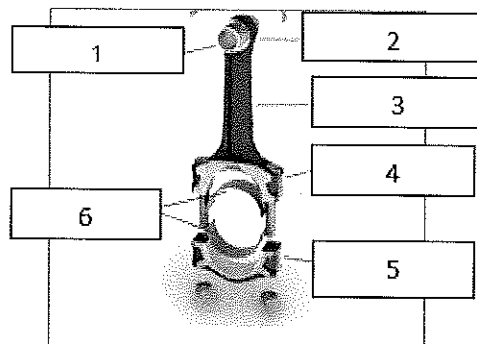

Ans:

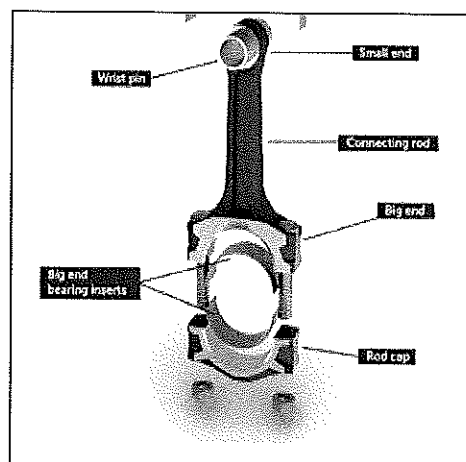

## Section – C

03X03 = 09 Marks

Q-9. Explain gasoline fuel supply system components.

Ans:



## BHARTIYA SKILL DEVELOPMENT UNIVERSITY

**Air meter:** - A mass (air) flow sensor (MAF) is a sensor used to determine the mass flow rate of air entering a fuel-injected internal combustion engine.

The air mass information is necessary for the engine control unit (ECU) to balance and deliver the correct fuel mass to the engine. Air changes its density with temperature and pressure. In automotive applications, air density varies with the ambient temperature, altitude and the use of forced induction, which means that mass flow sensors are more appropriate than volumetric flow sensors for determining the quantity of intake air in each cylinder.

There are two common types of mass airflow sensors in use on automotive engines. These are the vane meter and the hot wire. Neither design employs technology that measures air mass directly. However, with additional sensors and inputs, an engine's ECU can determine the mass flow rate of intake air.

Both approaches are used almost exclusively on electronic fuel injection (EFI) engines. Both sensor designs output a 0.0–5.0 volt or a pulse-width modulation (PWM) signal that is proportional to the air mass flow rate, and both sensors have an intake air temperature (IAT) sensor incorporated into their housings for most post on-board diagnostics (OBDII) vehicles. Vehicles prior to 1996 could have MAF without an IAT.

When a MAF sensor is used in conjunction with an oxygen sensor, the engine's air/fuel ratio can be controlled very accurately. The MAF sensor provides the open-loop controller predicted air flow information (the measured air flow) to the ECU, and the oxygen sensor provides closed-loop feedback in order to make minor corrections to the predicted air mass. Also see manifold absolute pressure sensor (MAP sensor).

### **Throttle body:**

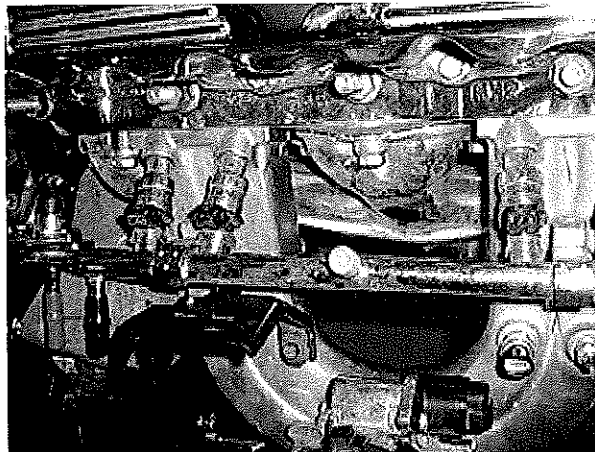

Fuel rail connected to the injectors that are mounted just above the intake manifold on a four-cylinder engine.

Fuel injection is the introduction of fuel in an internal combustion engine, most commonly automotive engines, by the means of an injector.

All diesel engines use fuel injection by design. Petrol engines can use gasoline direct injection, where the fuel is directly delivered into the combustion chamber, or indirect injection where the fuel is mixed with air before the intake stroke.

On petrol engines, fuel injection replaced carburetors from the 1980s onward. The primary difference between carburetion and fuel injection is that fuel injection atomizes the fuel



## BHARTIYA SKILL DEVELOPMENT UNIVERSITY

through a small nozzle under high pressure, while a carburetor relies on suction created by intake air accelerated through a Venturi tube to draw the fuel into the airstream.

- **Sensors:** Engine Sensors: In order to provide the correct amount of fuel for every operating condition, the engine control unit (ECU) has to monitor a huge number of input sensors. Here are just a few:
  - **Mass airflow sensor** - Tells the ECU the mass of air entering the engine
  - **Oxygen sensor(s)** - Monitors the amount of oxygen in the exhaust so the ECU can determine how rich or lean the fuel mixture is and make adjustments accordingly
  - **Throttle position sensor** - Monitors the throttle valve position (which determines how much air goes into the engine) so the ECU can respond quickly to changes, increasing or decreasing the fuel rate as necessary
  - **Coolant temperature sensor** - Allows the ECU to determine when the engine has reached its proper operating temperature
  - **Voltage sensor** - Monitors the system voltage in the car so the ECU can raise the idle speed if voltage is dropping (which would indicate a high electrical load)
  - **Manifold absolute pressure sensor** - Monitors the pressure of the air in the intake manifold
  - The amount of air being drawn into the engine is a good indication of how much power it is producing; and the more air that goes into the engine, the lower the manifold pressure, so this reading is used to gauge how much power is being produced.
  - **Engine speed sensor** - Monitors engine speed, which is one of the factors used to calculate the pulse width

There are two main types of control for **multi-port** systems: The fuel injectors can all open at the same time, or each one can open just before the intake valve for its cylinder opens (this is called **sequential multi-port fuel injection**).

The advantage of sequential fuel injection is that if the driver makes a sudden change, the system can respond more quickly because from the time the change is made, it only has to wait only until the next intake valve opens, instead of for the next complete revolution of the engine.

**Fuel rail:** The main function of the fuel rail consists in the optimal distribution of the fuel (gasoline, methane, etc.) to the injectors in the high or low pressure supply systems of endothermic engines.

It consists of a duly sized piping that fits the injector housings, the fixing brackets to the air intake manifold or to the motor cylinders head, connections for fuel inlet and, if necessary, fuel recirculation in the tank, the housings for the fuel temperature and pressure sensors, the



housing for an internal discharge control valve, if necessary, and the supports for the electrical wirings of the assembled electromechanical components.

## Gasoline fuel rail

The fuel rail for gasoline engines can be made in thermoplastic material with high mechanical, thermal or chemical resistance or in steel.

The operating pressure is obtained and maintained through a pressure regulator that can be incorporated into the rail (systems equipped with fuel recirculation) or in the fuel pump (systems without recirculation). Rail design is based on instantaneous flow rate control requirements

Q-10. Explain fuel efficiency test procedure.

ANS:

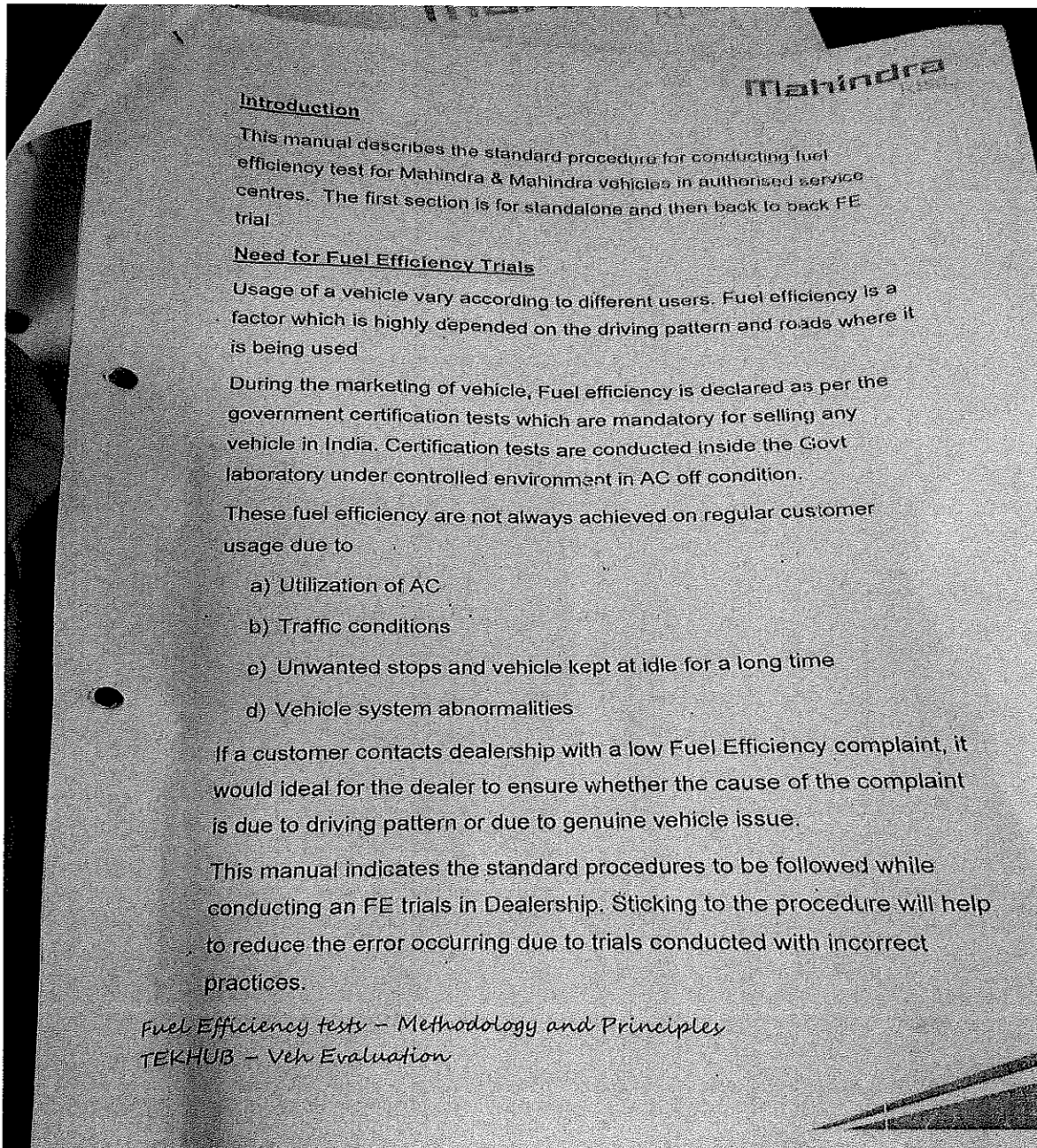

Procedure for FE trials

Preliminary activities

- Understand the customer complaint thoroughly and note down the Fuel efficiency values specified by the customers
- Confirm whether the customer has measured the Fuel efficiency by tank full to tank full method or by using the AFE from infotainment system or any other techniques if any.
- Collect the details regarding the Fuel filling station where the customer is doing fuel filling for conducting FE trials.
- Make sure the vehicle has undergone all the periodic maintenance as per the service schedule.
- Inspect the vehicle for
  - A) Abnormal noise / vibrations ✓
  - B) Air leakage from intake ✓
  - C) Abnormal smoke (Black, white or Blue) ✓
  - D) Wheel freeness – (Brake grabbing and wheel bearing freeness)
  - E) AC performance if trial is to be done with AC – (Filter conditions, clean if necessary. AC cooling, whether it's as per normal vehicle etc.)
- Make sure that the vehicle is having tyres in good condition. ✓  
Ensure that the air pressure is maintained as per the specs. The tyre pressure has to be checked in cold. If in doubt- start the trial in morning after checking the tyre pressure in cold.

Fuel Efficiency tests – Methodology and Principles  
TEKHUB – Veh Evaluation

14-11052 = 178 km  
Mahindra  
R152

Mahindra  
R152

- Please arrange to remove any punctures if any. Reduced air pressure on tyres can increase the fuel consumption considerably.
- Ensure that the vehicle is equipped with correct EMS dataset.

### FE trials

1. Allow the vehicle to cool down for an hour or more before fuel filling (if possible)
2. After preliminary checkup, take the vehicle to the Fuel filling station and fill the fuel upto the tip of filler neck.
3. Once the fuel has reached upto to the tip, close the filler cap and shake the vehicle side wise for 2 – 3 times. This will allow the air entrapped inside the fuel tank to come out and the fuel level to reduce and go inside the tank
4. Repeat step 3, two times and observe whether the fuel level is reducing each time after shaking the vehicle.
5. If the fuel is not reducing even after shaking, close the filler cap properly and then go to step 6, otherwise repeat step 3.
6. Note down the odometer reading & reset the trip meter to zero.
7. Once the data is collected, start driving the vehicle normally through the customer specified route through the FE trial driver

### FE trial Driver

- a) Make sure the driver has a valid driving license.
- b) Driver should be well versed in driving the said model. Driver should not have the habit of clutch riding. He should not be driving with left leg resting on top of the clutch. ( tip : In our latest vehicles which are having gear display, if the clutch is pressed then it will show – instead of gear)

Fuel Efficiency tests – Methodology and Principles

Veh. Evaluation

- c) Driver should drive the vehicle like a normal customer.  
 Unnecessary braking, engine revving and gear shifting should be avoided.
8. It is critical to conduct trials for at least 150 Km or above for fuel efficiency trials. <sup>80-100 ≈ 160</sup>
9. Conducting trials for lesser kilometers will increase the chances of having error while calculating fuel efficiency in tank full to tank full method. Once the trials are completed, follow steps 1, 3, 4, 5, 6.
10. The speeds should be controlled within 80 to 100. Take care to avoid sudden acceleration and last minute braking (use of engine as brake recommended)
11. Use appropriate gear shift points to avoid engine revving or engine lugging by staying in the optimum Engine RPM and torque band. <sup>2v, 4v, 6v, 8v.</sup>
12. AC should be in Recirculation mode; Blower speed : 2; Maximum cooling. <sup>1</sup> <sup>2</sup> <sup>3</sup>

Loading:

For passenger: D + 3

For commercial: test under GVW or no load conditions. If superstructure already built then it should be up to GVW.

Back to Back trials

Back to Back Fuel Efficiency trials are conducted when the Fuel efficiency of one vehicle has to be compared with another vehicle.

In back to back trials, both the vehicles has to be driven in same route on similar speeds. It is compulsory that the fuel is filled at the same fuel station to obtain accurate results.

Fuel filling and driving patterns as defined in the FE trial section to be followed.

Some other factors to be considered specifically for Back to Back trials are:

- A. It is recommended to use vehicles which have similar odometer readings for better comparison.
- B. Avoid aggressive driving and racing during trials
- C. It is recommended to keep a distance of around 100 m in city and 500 m in highway to reduce the effect of following too closely and also to avoid the benefit of less air drag for 2nd vehicle.
- D. Maintain a constant gap between vehicles and match the speed of the leading vehicle.
- E. Interchange drivers (at half point if there is 2 vehicles) to evenly spread the driving effect on each vehicle
- F. It is advisable to do the oil change on both the vehicle (if possible) before doing the trial. This can rule out the variations.



Q-11. Explain engine cooling system.

Ans: A car engine produces a lot of heat when it is running, and must be cooled continuously to avoid engine damage.

Generally, this is done by circulating coolant liquid usually water mixed with an antifreeze solution through special cooling passages. Some engines are cooled by air flowing over finned cylinder casings.

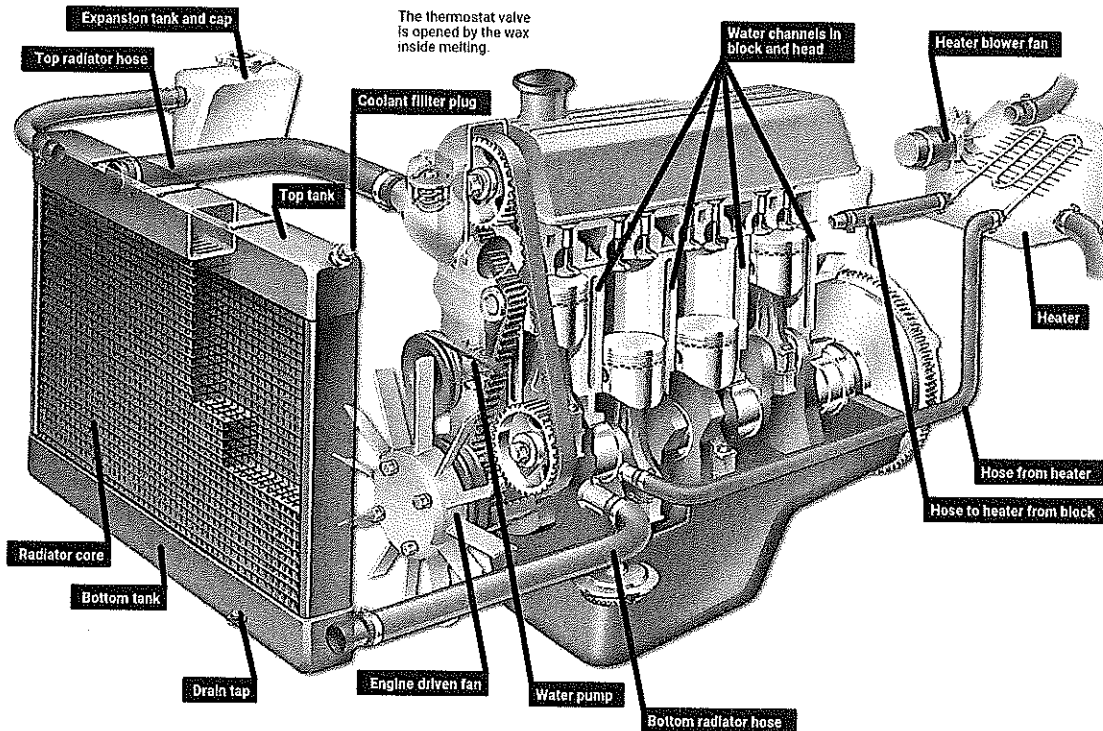

## How the coolant circulates

A typical water-cooling system with an engine-driven fan: note the bypass hose taking off hot coolant for the heater. The pressure cap on the expansion tank has a spring-loaded valve which opens above a certain pressure.

## A water-cooled cooling system

A water-cooled engine block and cylinder head have interconnected coolant channels running through them. At the top of the cylinder head all the channels converge to a single outlet.

A pump, driven by a pulley and belt from the crankshaft, drives hot coolant out of the engine to the radiator, which is a form of heat exchanger.

Unwanted heat is passed from the radiator into the air stream, and the cooled liquid then returns to an inlet at the bottom of the block and flows back into the channels again.

Usually the pump sends coolant up through the engine and down through the radiator, taking advantage of the fact that hot water expands, becomes lighter and rises above cool water when heated. Its natural tendency is to flow upwards, and the pump assists circulation.

The radiator is linked to the engine by rubber hoses, and has a top and bottom tank connected by a core a bank of many fine tubes.

The tubes pass through holes in a stack of thin sheet-metal fins, so that the core has a very large surface area and can lose heat rapidly to the cooler air passing through it.



## BHARTIYA SKILL DEVELOPMENT UNIVERSITY

On older cars the tubes run vertically, but modern, low-fronted cars have crossflow radiators with tubes that run from side to side.

In an engine at its ordinary working temperature, the coolant is only just below normal boiling point.

The risk of boiling is avoided by increasing the pressure in the system, which raises the boiling point.

The extra pressure is limited by the radiator cap, which has a pressure valve in it. Excessive pressure opens the valve, and coolant flows out through an overflow pipe.

In a cooling system of this type there is a continual slight loss of coolant if the engine runs very hot. The system needs topping up from time to time.

Later cars have a sealed system in which any overflow goes into an expansion tank, from which it is sucked back into the engine when the remaining liquid cools.

### How the fan helps

The radiator needs a constant flow of air through its core to cool it adequately. When the car is moving, this happens anyway; but when it is stationary a fan is used to help the airflow.

The fan may be driven by the engine, but unless the engine is working hard, it is not always needed while the car is moving, so the energy used in driving it wastes fuel.

To overcome this, some cars have a viscous coupling a fluid clutch worked by a temperature sensitive valve that uncouples the fan until the coolant temperature reaches a set point.

Other cars have an electric fan, also switched on and off by a temperature sensor.

To let the engine warm up quickly, the radiator is closed off by a thermostat, usually sited above the pump. The thermostat has a valve worked by a chamber filled with wax.

When the engine warms up, the wax melts, expands and pushes the valve open, allowing coolant to flow through the radiator.

When the engine stops and cools, the valve closes again.

Water expands when it freezes, and if the water in an engine freezes it can burst the block or radiator. So antifreeze usually ethylene glycol is added to the water to lower its freezing point to a safe level.

Antifreeze should not be drained each summer; it can normally be left in for two or three years.

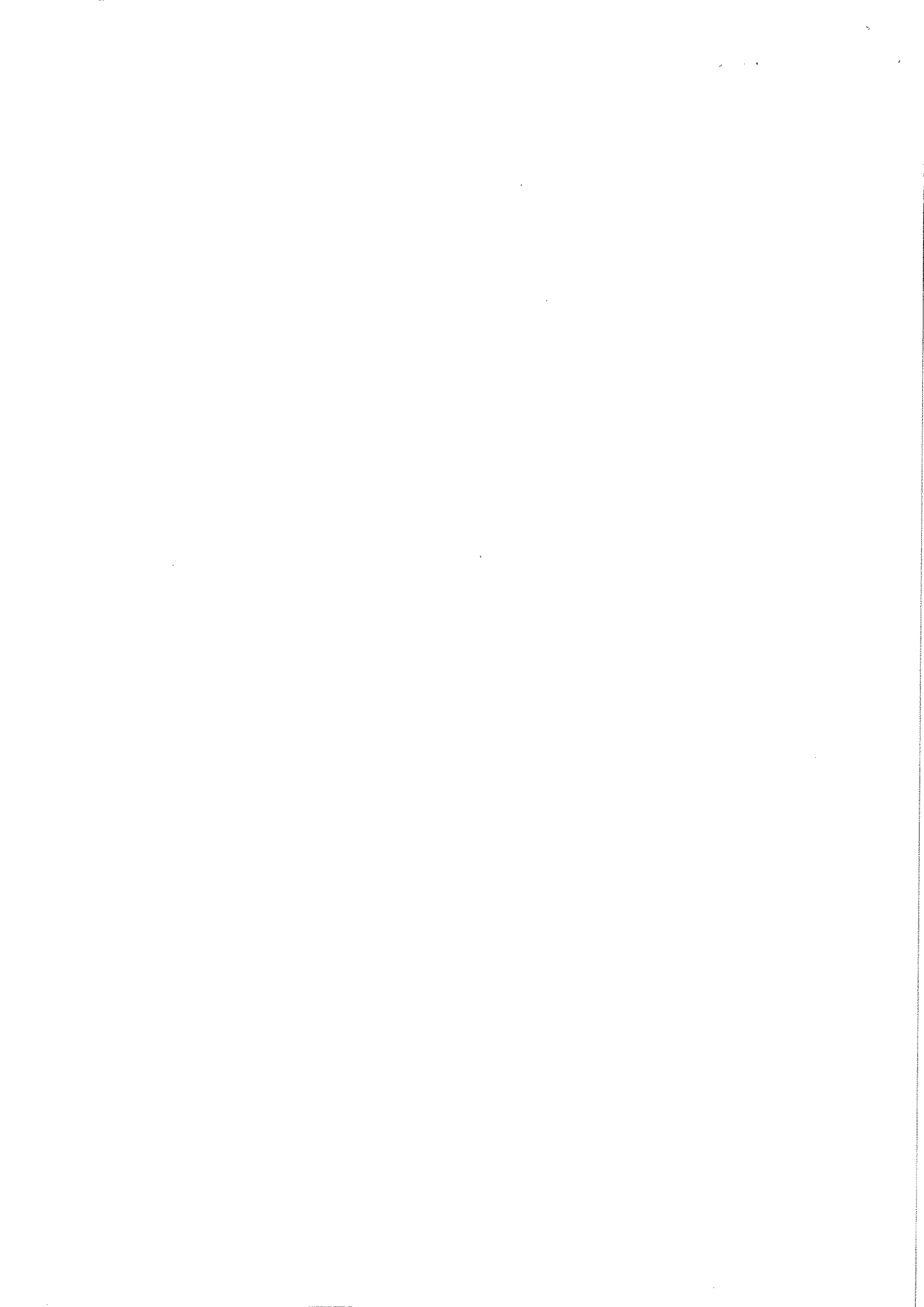

**BHARTIYA SKILL DEVELOPMENT UNIVERSITY**

**School of Automotive Skills  
Session: 2019-20 (Summer Semester)  
B. Voc. Program, 3<sup>rd</sup> Semester  
2<sup>nd</sup> In-Sem. Examination**

**Course Code: AUT1302****Time: 1 Hour****Course Name: Automotive Braking, Suspension & Steering****Max. Marks: 20****Instruction:**

1. Attempt all questions from section A, each question carries one mark.
2. Attempt all questions from section B, each question carries two mark.
3. Attempt all questions from section C each question carries three mark

**Section – A****Directions: Select any one correct answer from the given options:****05X01 = 05 Marks**

Q.1 Which component of suspension system is made of a special round spring steel wrapped in a helix shape?

- a) Leaves of leaf spring
- b) Coil Spring
- c) Bushes
- d) None of the above

Q.2 The leaves of a leaf spring are held together by a:

- a) Centering Pin
- b) Centre Bolt
- c) Both a & b
- d) None of them

Q.3 Which type of suspension system has both right and left wheel attached to the same solid axle?

- a) Independent
- b) Rigid
- c) Flexible
- d) None of the above

Q.4 Which type of suspension is also known as SLA Type of suspension?

- a) Macpherson Strut
- b) Wishbone
- c) Spring
- d) Rigid

Q.5 Which material is used to manufacture springs used in suspension system?

- a) Mild Steel
- b) Spring Steel
- c) Stainless Steel
- d) High Carbon Steel

### **Section – B**

03X02 = 06 Marks

- Q.6 What are the factors responsible for strength and handling characteristics of a coil spring?
- Q.7 What do you understand by an independent suspension system? Also write their names.
- Q.8 What is the purpose and function of a shock absorber?

### **Section – C**

03X03 = 09 Marks

- Q.9. Explain the difference between a single tube and double tube shock absorber with the help of a diagram.
- Q.10 Explain the methods for diagnosis/testing of a suspension system to identify the related problems.
- Q.11 Write a short note on:
- a. Leaf Springs
  - b. Spring Rate



# BHARTIYA SKILL DEVELOPMENT UNIVERSITY

School of Automotive Skills  
Session: 2019-20 (Summer Semester)  
B. Voc. Program, 3<sup>rd</sup> Semester  
2<sup>nd</sup> In-Sem. Examination

Course Code: AUT1302

Time: 1 Hour

Course Name: Automotive wheel care & steering system

Max. Marks: 20

Instruction:

1. Attempt all questions from section A, each question carries one mark.
2. Attempt all questions from section B, each question carries two mark.
3. Attempt all questions from section C each question carries three mark

## Section – A

Directions: Select any one correct answer from the given options:

05X01 = 05 Marks

Q.1 Which component of suspension system is made of a special round spring steel wrapped in a helix shape?

- a) Leaves of leaf spring
- b) **Coil Spring**
- c) Bushes
- d) None of the above

Q.2 The leaves of a leaf spring are held together by a:

- a) Centering Pin
- b) Centre Bolt
- c) **Both a & b**
- d) None of them

Q.3 Which type of suspension system has both right and left wheel attached to the same solid axle?

- a) Independent
- b) **Rigid**
- c) Flexible
- d) None of the above

Q.4 Which type of suspension is also known as SLA Type of suspension?

- a) Macpherson Strut
- b) **Wishbone**
- c) Spring
- d) Rigid

Q.5 Which material is used to manufacture springs used in suspension system?

- a) Mild Steel
- b) **Spring Steel**
- c) Stainless Steel
- d) High Carbon Steel

## Section – B

03X02 = 06 Marks

Q.6 What are the factors responsible for strength and handling characteristics of a coil spring?

**Coil springs** are made of special round spring steel wrapped in a helix shape. The strength and handling characteristics of a coil spring depend on the following:

1. Coil diameter
2. Number of coils
3. Height of spring
4. Diameter of the steel coil that forms the spring.

Q.7 What do you understand by an independent suspension system? Also write their names.

**Independent suspension system:** Allows one wheel to move up and down with minimum effect to the other.

**Independent suspension system** is divided into 2 parts

- 1) MacPherson Sturt
- 2) Wish Bone

Q.8 What is the purpose and function of a shock absorber?

The major purpose of any shock or strut is to control ride and handling. Standard shock absorbers do not support the weight of a vehicle. The springs support the weight of the vehicle; the shock absorbers control the actions and reactions of the springs. Shock absorbers are also called dampers.

## Section – C

03X03 = 09 Marks

Q.9. Explain the difference between a single tube and double tube shock absorber with the help of a diagram.

- The hydraulic shock absorber operates on the principle of fluid being forced through a small opening (orifice). Besides small openings, pressure relief valves are built into most shock absorbers to control vehicle ride under all operating conditions. The greater the pressure drop of the fluid inside the shock and the greater the amount of fluid moved through the orifice, the greater the amount of dampening; therefore, larger shock absorbers can usually provide better dampening than smaller units.

# BHARTIYA SKILL DEVELOPMENT UNIVERSITY

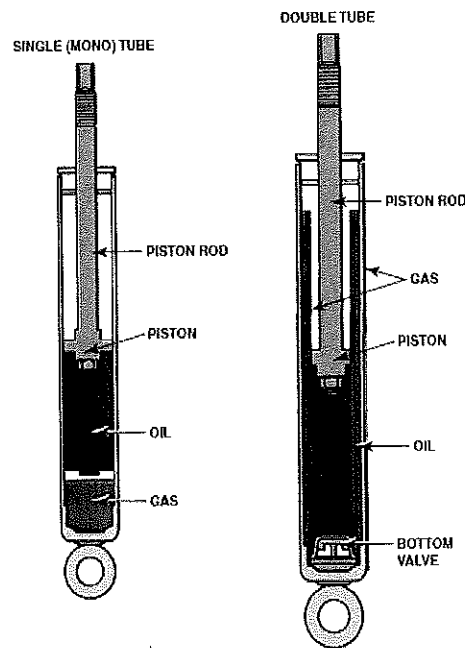

**FIGURE 112-49** Gas-charged shock absorbers are manufactured with a double-tube design similar to conventional shock absorbers and with a single or monotube design.

Q.10 Explain the methods for diagnosis/testing of a suspension system to identify the related problems.

**ROAD TEST DIAGNOSIS:** If possible, perform a road test of the vehicle with the owner of the vehicle. It is also helpful to have the owner drive the vehicle. While driving, try to determine when and where the noise or problem occurs, such as the following:

1. In cold or warm weather
2. With cold or warm engine/vehicle
3. While turning, left only, right only
  - A proper road test for any suspension system problem should include the following:
    1. Drive beside parked vehicles
    2. Drive into driveways.
    3. Drive in reverse while turning
    4. Drive over a bumpy road

**DRY PARK TEST (SUSPENSION):** A **dry park test** can also be used to help locate worn or defective suspension components. The dry park test is performed by having an assistant move the steering wheel side to side while feeling and observing for any free play in the steering or suspension.

1. Front wheel bearings
2. Control arm bushing wear or movement.
3. Ball joint movement.

**NOTE:** The dry park test (and many other chassis system tests) relies on the experience of the technician to be able to judge normal wear from abnormal wear. It is extremely important

that all beginning technicians work closely with an experienced technician to gain this knowledge.

Q.11 Write a short note on:

a. Leaf Springs

**LEAF SPRINGS:** Leaf springs are constructed of one or more strips of long, narrow spring steel. These metal strips, called leaves, are assembled with plastic or synthetic rubber insulators between the leaves, allowing for freedom of movement during spring operation. The ends of the longest spring leaf are rolled or looped to form eyes. Rubber bushings are installed in the eyes of the spring and act as noise and vibration insulators. The leaves are held together by a **centre bolt**, also called a *centring pin*.

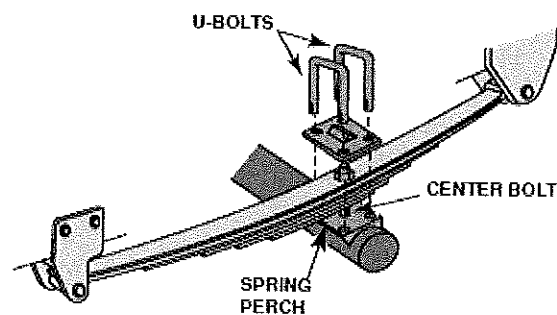

b. Spring Rate

- The spring rate (K) for coil springs is expressed by the formula:

$$K = \frac{Gd^4}{8ND^3}$$

- Where, G 11,250,000 (constant for steel), d diameter of wire, N number of coils  
D diameter of the coil

Types of spring on basis of spring rate

- A **constant-rate spring** compresses at the same rate regardless of the amount of weight that is applied.
- **Variable-rate springs** come in a variety of shapes and compress more slowly as weight is applied.



# BHARTIYA SKILL DEVELOPMENT UNIVERSITY

Registration No.: .....

**School of Automotive Skills**  
**Session: 2019-20 (Summer Semester)**  
**B. Voc. Program, 3<sup>rd</sup> Semester,**  
**2<sup>nd</sup> In-Sem. Examination**

**Course Code:** AUT1303

**Time: 1 Hour**

**Course Name:** Automotive Body Works

**Max. Marks: 20**

**Instruction:**

1. Answer all questions from "**Section-A**", each question carries 01 mark.
2. Answer all questions from "**Section-B**", each question carries 02 marks.
3. Answer all questions from "**Section-C**", each question carries 03 marks.

**Section – A**

**Directions:** Select any one correct answer from the given options: 05X01 = 05 Marks

- 1) A unibody strut tower is being installed using a GMAW welder. Technician "A" says that a mixture of 75% argon and 25% helium could be used. Technician "B" says that a mixture of 75% argon and 25% carbon dioxide could be used. Who is right?
  - a) Only A
  - b) Only B
  - c) Both A & B
  - d) Neither A nor B
- 2) What term describes the ability to stretch metal's material and have metal's material return to its original shape?
  - a) Elastic deformation
  - b) Tensile strength
  - c) Work hardening
  - d) Yield strength
- 3) How is body filler mixed to ensure proper catalyzation?
  - a) Shake hardener and filler in small container.
  - b) Mix filler and hardener on cardboard mixing board.
  - c) Fold coloured hardener and filler together until uniform in colour.
  - d) Stir coloured hardener and filler together until uniform in colour.
- 4) The metal used for body building of an automobile is generally:
  - a) Cast iron
  - b) Steel
  - c) Copper
  - d) Aluminium
- 5) Snips are used for:
  - a) Cutting thick layer of metal
  - b) Cutting sheet metal
  - c) Cutting wooden blocks
  - d) Cutting external threads

**Section – B**

03X02 = 06 Marks

- 6) Write the advantages of using fiber glass in an automobile body.
- 7) Give the reasons of using plug weld during body repair.
- 8) What is PDR? Also write the advantages of using PDR.

**Section – C**

03X03 = 09 Marks

- 9) Discuss the advantages and applications of insulating glass used in an automobile.
- 10) Explain the performance and features of bullet proof glass used in an automobile.
- 11) Write short notes on:
  - a) Degreaser
  - b) Primer- Surfacer
  - c) Panel bonding adhesive



# BHARTIYA SKILL DEVELOPMENT UNIVERSITY

Registration No.: .....

**School of Automotive Skills**  
**Session: 2019-20 (Summer Semester)**  
**B. Voc. Program, 3<sup>rd</sup> Semester,**  
**2<sup>nd</sup> In-Sem. Examination**

**Course Code:** AUT1303

**Time:** 1 Hour

**Course Name:** Automotive Body Works

**Max. Marks:** 20

**Instruction:**

1. Answer all questions from "**Section-A**", each question carries 01 mark.
2. Answer all questions from "**Section-B**", each question carries 02 marks.
3. Answer all questions from "**Section-C**", each question carries 03 marks.

**Section – A**

**Directions:** Select any one correct answer from the given options: 05X01 = 05 Marks

- 1) A unibody strut tower is being installed using a GMAW welder. Technician "A" says that a mixture of 75% argon and 25% helium could be used. Technician "B" says that a mixture of 75% argon and 25% carbon dioxide could be used. Who is right?
  - a) Only A
  - b) Only B
  - c) Both A & B
  - d) Neither A nor B
- 2) What term describes the ability to stretch metal's material and have metal's material return to its original shape?
  - a) Elastic deformation
  - b) Tensile strength
  - c) Work hardening
  - d) Yield strength
- 3) How is body filler mixed to ensure proper catalyzation?
  - a) Shake hardener and filler in small container.
  - b) Mix filler and hardener on cardboard mixing board.
  - c) Fold coloured hardener and filler together until uniform in colour.
  - d) Stir coloured hardener and filler together until uniform in colour.
- 4) The metal used for body building of an automobile is generally:
  - a) Cast iron
  - b) Steel
  - c) Copper
  - d) Aluminium
- 5) Snips are used for:
  - a) Cutting thick layer of metal
  - b) Cutting sheet metal
  - c) Cutting wooden blocks
  - d) Cutting external threads

**Section – B**

03X02 = 06 Marks

- 6) Write the advantages of using fiber glass in an automobile body.
- 7) Give the reasons of using plug weld during body repair.
- 8) What is PDR? Also write the advantages of using PDR.

**Section – C**

03X03 = 09 Marks

- 9) Discuss the advantages and applications of insulating glass used in an automobile.
- 10) Explain the performance and features of bullet proof glass used in an automobile.
- 11) Write short notes on:
  - a) Degreaser
  - b) Primer- Surfacer
  - c) Panel bonding adhesive



# BHARTIYA SKILL DEVELOPMENT UNIVERSITY

Registration No.: .....

**School of Automotive Skills**  
**Session: 2019-20 (Summer Semester)**  
**B. Voc. Program, 3<sup>rd</sup> Semester,**  
**2<sup>nd</sup> In-Sem. Examination**

**Course Code:** AUT1303

**Time:** 1 Hour

**Course Name:** Automotive Body Works

**Max. Marks:** 20

**Instruction:**

1. Answer all questions from "**Section-A**", each question carries 01 mark.
2. Answer all questions from "**Section-B**", each question carries 02 marks.
3. Answer all questions from "**Section-C**", each question carries 03 marks.

**Section – A**

**Directions:** Select any one correct answer from the given options: 05X01 = 05 Marks

- 1) A unibody strut tower is being installed using a GMAW welder. Technician "A" says that a mixture of 75% argon and 25% helium could be used. Technician "B" says that a mixture of 75% argon and 25% carbon dioxide could be used. Who is right?
  - a) Only A
  - b) Only B
  - c) Both A & B
  - d) Neither A nor B

**Ans: - b)**

- 2) What term describes the ability to stretch metal's material and have metal's material return to its original shape?
  - a) Elastic deformation
  - b) Tensile strength
  - c) Work hardening
  - d) Yield strength

**Ans: - a)**

- 3) How is body filler mixed to ensure proper catalyzation?
  - a) Shake hardener and filler in small container.
  - b) Mix filler and hardener on cardboard mixing board.
  - c) Fold coloured hardener and filler together until uniform in colour.
  - d) Stir coloured hardener and filler together until uniform in colour.

**Ans: - c)**

- 4) The metal used for body building of an automobile is generally:
  - a) Cast iron
  - b) Steel
  - c) Copper
  - d) Aluminium

**Ans: - b)**

5) Snips are used for:

- |                                 |                             |
|---------------------------------|-----------------------------|
| a) Cutting thick layer of metal | c) Cutting wooden blocks    |
| b) Cutting sheet metal          | d) Cutting external threads |

**Ans: - b)**

### Section – B

03X02 = 06 Marks

6) Write the advantages of using fiber glass in an automobile body.

**Ans: -**

The advantages of using fiber glass in an automobile body are as follows:

- Fiberglass combines its light weight with an inherent strength to provide a weather resistant finish with a variety of surface textures.
- High tensile strength, temperature resistance and dimensional stability.
- Provides good impact resistance and high resistivity to weathering elements.
- Resistance from corrosion.

7) Give the reasons of using plug weld during body repair.

**Ans: -**

A plug weld is used to fasten two pieces of metal together using a welder. When joining the pieces, a hole is drilled into the top piece and it is laid over the bottom one. A weld is then made by running a bead inside of the drilled hole, thereby holding the two pieces together. When doing auto body repair, this type of weld is often used when spot welding is not applicable or reachable during replacing body panels.

8) What is PDR? Also write the advantages of using PDR.

**Ans: -**

Paintless Dent Repair (PDR), also known as Paintless Dent Removal, is an environmentally-friendly repair method that restores a vehicle's body to factory-like condition in a fraction of the time at a fraction of the cost. PDR can be used to remove dings and dents from vehicles, as well as body creases and hail damage.

**Advantages:**

- No repainting or body filler needed.
- Less expensive than traditional body repair
- No risk of paint overspray on other vehicle areas
- No risk of incorrect colour matching

## BHARTIYA SKILL DEVELOPMENT UNIVERSITY

### Section – C

03X03 = 09 Marks

9) Discuss the advantages and applications of insulating glass used in an automobile.

**Ans: -**

Insulating Glass is also called Insulated glass/ Hollow glass/ IGU/Double glazing glass/ Double glazed glass panel/ insulation glass and so on. It consists of two or more pieces of glass sheets and uses sealant gumming and aluminum or steel spacers which are filled with desiccant together. The hollow part is filled with dry air or inert gas with primary and secondary sealants. The double glazing glass usually is used with low e coating so that its energy-saving can be get the best effect. They are widely used for building curtain wall and windows as the functions of soundproof and energy conservation.

#### Performance Features

- Excellent in heat and sound insulation with inert gas;
- Saving energy and environmental protection;
- Eliminating the hoarfrost and dew effect;
- High wind pressure strength;
- Low dampness permeating rate;
- Not easy to be self-exploded;
- Difficult to come off for coating layer.

#### Applications

Insulating Glass is widely used for residence, hotel, office building, school, hospital, shopping mall and so on where the place needs air condition. And it also can be used for train, automobile, vessel, cabinet freezer and so on.

- Window and door;
- Facades and curtain walls;
- Interior partition;
- Refrigerator.

10) Explain the performance and features of bullet proof glass used in an automobile.

**Ans: -**

Bullet Proof Glass is also known as Bullet Resistant Glass/anti-bullet glass/safe glass/Armored Glass/Ballistic Glass/Transparent Armor and so on. It's a type of strong but optically transparent glass which is particularly resistant to being penetrated when struck. Bullet Proof Glass is made of a combination of two or more types of glass. And it's constructed using polycarbonate, thermoplastic and layers of laminated glass.

All of our Bullet Proof Glass are made in accordance with the Standard GA165-1997 and certified by technical experts of the National Public Security Ministry Shanghai Inspection Centers.

#### Performance Features:

- Safety bullet proof;
- Anti low temperature;
- Guard against theft, anti-explosion;
- Against typhoon;
- Strong capability to withstand larger bomb explosion shock lading;
- High safety. The bullets melted in the surface of glass and no splash shatter on the back after shooting, so it protects the safety of the glass-housed crowds;
- Successfully proof the shooting at 10m of 79-type Micro-SMG, 7.62mm steel core ammunition, AK74-type auto, rifle and so on.

11) Write short notes on:

a) Degreaser

**Ans: -**

can remove grease, oil, smog, flies, oil, dirt and stains. On **cars** it can be **used as a** detergent to wash the engine, clean the rims and also eliminate traffic film on the bodywork, always by using different dilutions.

b) Primer- Surfacer

**Ans: -**

Offering a high solids content, primer-Surfacer (also known as high build primer) are used to cover slight imperfections such as sanding scratches. These products should not be confused with or used as a filler, as they are not intended to fill more than slight scratches. Primer-Surfacer is an under coat product designed to be sanded smooth.

c) Panel bonding adhesive

**Ans: -**

- One of the biggest recent innovations in automotive bodywork is the development and use of panel-bonding adhesives.
- As automotive manufacturers have worked to decrease the overall weight of their vehicles, they have begun using body components made of composites, rather than steel.
- Bonding adhesives were developed to handle composite materials, which cannot be welded using the same methods as those used for welding steel.
- Taking a good thing further, panel-bonding adhesives are now available for use with steel panels.



# BHARTIYA SKILL DEVELOPMENT UNIVERSITY

School of Automotive Skills

Session: 2019-20 (Summer Semester)

B. Voc. Program, 3<sup>rd</sup> Semester,

2<sup>nd</sup> In-Sem. Examination

Course Code: AUT1304

Time: 1 Hour

Course Name: Automotive Refinish Painting

Max. Marks: 20 marks

**Instruction:**

1. Answer all questions from section A, each question carries one mark
2. Answer all question from section B, each question carries two mark.
3. Answer all question from section C, each question carries three mark.

**Section – A**

05X01 = 05 Marks

Q-1. What does 1-k represent?

- |                          |                             |
|--------------------------|-----------------------------|
| a. 1000                  | c. Product without hardener |
| b. Product with hardener | d. None of these            |

Q-2. Wash primer is a.....primer?

- |        |                      |
|--------|----------------------|
| a. 1 K | c. Both a & b        |
| b. 2 K | d. None of the above |

Q-3. What is the best way of removing the dust particles after putty dry sanding?

- |                          |                            |
|--------------------------|----------------------------|
| a. Air blowing           | c. Cleaning with degreaser |
| b. Cleaning with thinner | d. Both (a) and (c)        |

Q-4. What is the mixing ratio (in gram) of polyester putty & hardener?

- |           |           |
|-----------|-----------|
| a. 100: 2 | c. 100:12 |
| b. 100:10 | d. 100:5  |

Q-5. Which of the following paint layer is not a part of refinish painting?

- |                                    |                    |
|------------------------------------|--------------------|
| a. Electrophoretic dip coat primer | c. Polyester putty |
| b. Epoxy primer                    | d. Body filler     |

**Section – B**

03X02 = 06 Marks

- Q-6. What is the difference between body filler and putty?
- Q-7. What are the different types of angles used for panel inspection?
- Q-8. What is Metamerism?

**Section – C**

03X03 = 09 Marks

- Q-9. What are the factors that influences the colors?
- Q-10. What are the causes of runs on the panel? Explain its precaution and remedies.
- Q-11. Explain different types of paint defects and its causes.



Registration No.: .....

# BHARTIYA SKILL DEVELOPMENT UNIVERSITY

School of Automotive Skills

Session: 2019-20 (Summer Semester)

B. Voc. Program, 3<sup>rd</sup> Semester,

2<sup>nd</sup> In-Sem. Examination

Course Code: AUT1304

Time: 1 Hour

Course Name: Automotive Refinish Painting

Max. Marks: 20 marks

## Instruction:

1. Answer all questions from section A, each question carries one mark
2. Answer all question from section B, each question carries two mark.
3. Answer all question from section C, each question carries three mark.

## Section – A

05X01 = 05 Marks

Q-1. What does 1-k represent?

- |                                 |                             |
|---------------------------------|-----------------------------|
| a. 1000                         | c. Product without hardener |
| b. <b>Product with hardener</b> | d. None of these            |

Q-2. Wash primer is a.....primer?

- |               |                      |
|---------------|----------------------|
| a. <b>1 K</b> | c. Both A & B        |
| b. 2 K        | d. None of the above |

Q-3. What is the best way of removing the dust particles after putty dry sanding?

- |                          |                            |
|--------------------------|----------------------------|
| a. Air blowing           | c. Cleaning with degreaser |
| b. Cleaning with thinner | d. <b>Both (a) and (c)</b> |

Q-4. What is the mixing ratio (in gram) of polyester putty & hardener?

- |                  |           |
|------------------|-----------|
| a. <b>100: 2</b> | c. 100:12 |
| b. 100:10        | d. 100:5  |

Q-5. Which of the following paint layer is not a part of refinish painting?

- |   |                    |
|---|--------------------|
| a. <b>Electrophoretic dip coat primer</b> | c. Polyester putty |
| b. Epoxy primer                           | d. Body filler     |

## Section – B

03X02 = 06 Marks

Q-6. What is the difference between body filler and putty?

Ans. Body filler is used when the size of dent is large because the density of body filler is lesser than the putty due to bigger grain size.

Putty is used to finish the layer of body filler and to fill the scratches and small dents as the density of putty is more than body filler due to smaller grain size.

Q-7. What are the different types of angles used for panel inspection?

Ans. Head on angle, Near specular angle, Side on angle

Q-8. What is Metamerism?

Ans. Metamerism is the change of colour influenced by another light source (esp. during darkness).

Metamerism can be avoided by adjusting colors with their "proper" tinting.

## Section – C

03X03 = 09 Marks

Q-9. What are the factors that influence the colors?

Color influencing factors are:

- Ans. Environment
- Product
- Application
- Equipment

Q-10. What are the causes of runs on the panel? Explain its precaution and remedies.

- Ans.

Causes:

- Incorrect spraying viscosity, spraying technique.
- Defective spray gun set up.
- Incorrect spraying pressure.
- Temperature of paint, substrate or spray booth too low.
- Incorrect choice of hardeners and thinners.

**Prevention:-**

- Ensure that the spray gun is in good working order.
- Warm object and material up to room temperature of 20 °C/68 °F.
- Use correct combination of hardeners and thinners .

**Remedies:-**

- Sand and polish.
- Sand and repaint.

Q-11. Explain at least three different types of paint defects and its causes.

Ans.

- Clouding:

**Causes: -**

- Incorrect spraying viscosity, spraying technique, flash-off times, spray booth temperature.
- Defective spray gun set up, incorrect spraying pressure.
- Use of unsuitable thinner.

- Solvent popping:

**Causes: -**

- Insufficient drying of primer filler in corners, edges, and below decorative strips.
- Incorrect choice of hardeners and thinners.
- Film build too high.
- Wrong spraying technique.

- Orange peel

**Causes: -**

- Unsuitable combination of solvents or low quality solvents.
- Insufficient sanding of substrate.
- Incorrect spray gun set up.
- Excessive temperature.





**School of Automotive Skills**  
**Session: 2019-20 (Summer Semester)**  
**B. Voc. Program, 3rd Semester,**  
**2<sup>nd</sup> In-Sem. Examination**

**Course Code: AUT 1305**

**Time: 1 Hour**

**Course Name: Automotive electrical and A.C.**

**Max. Marks: 20**

**Instruction:**

1. Answer all questions from section A, each question carries one mark
2. Answer all question from section B, each question carries two mark.
3. Answer all question from section C, each question carries three mark.

**Section – A**

05X01 = 05 Marks

1. **What will be the effect on the resistance if temperature rise takes place?**
  - a) Resistance increases
  - b) Resistance decreases
  - c) Rho and R increases
  - d) Rho and R decreases
2. **Which of the following subatomic particle has lesser weight?**
  - a) Electron
  - b) Proton
  - c) Neutron
  - d) molecule
3. **Is it possible to flow current in reversed biased condition in diode?**
  - a) Yes, it is possible
  - b) Possible above threshold voltage only
  - c) No it is not possible
  - d) Possible when electron are in valence band
4. **What is the SI unit of capacitor?**
  - a) Coulomb
  - b) Stat farad
  - c) Farad
  - d) None of the above
5. **Magnetic field lines inside the magnet will flow in the direction of:**
  - a) North to south
  - b) No field lines inside it
  - c) South to north
  - d) None of the above



# BHARTIYA SKILL DEVELOPMENT UNIVERSITY

## Section – B

03X02 = 06 Marks

6. What is the difference between primary windings and secondary winding in step up transformer? Explain it in terms of Magnetic flux.
7. What do you mean by a piezo element? How a piezo crystal works?
8. What do you mean by self-induction in a coil? Explain with the help of diagram.

## Section – C

03X03 = 09 Marks

9. Explain the working principle of a transistor in electronic circuits.
10. What is the difference between forward biased and reversed biased diodes? Draw the electronic symbol of an NPN transistor.
11. Explain the process of current flow in an electrochemical cell.



**School of Automotive Skills**  
**Session: 2019-20 (Summer Semester)**  
**B. Voc. Program, 3rd Semester,**  
**2<sup>nd</sup> In-Sem. Examination**

**Course Code: AUT 1305**

**Time: 1 Hour**

**Course Name: Automotive electrical and A.C.**

**Max. Marks: 20**

**Instruction:**

1. Answer all questions from section A, each question carries one mark
2. Answer all question from section B, each question carries two mark.
3. Answer all question from section C, each question carries three mark.

**Section – A**

05X01 = 05 Marks

1. **What will be the effect on the resistance of conductor if temperature rise takes place?**
  - a) Resistance increases
  - b) **Resistance decreases**
  - c) Rho and R increases
  - d) Rho and R decreases
2. **Which of the following subatomic particle has lesser weight?**
  - a) **Electron**
  - b) Proton
  - c) Neutron
  - d) molecule
3. **Is it possible to flow current in reversed biased condition in diode?**
  - a) Yes, it is possible
  - b) **Possible above threshold voltage only**
  - c) No it is not possible
  - d) Possible when electron are in valence band
4. **What is the SI unit of capacitor?**
  - a) Coulomb
  - b) Stat farad
  - c) **Farad**
  - d) None of the above
5. **Magnetic field lines inside the magnet will flow in the direction of:**
  - a) North to south
  - b) No field lines inside it
  - c) **South to north**
  - d) None of the above



**Section – B**

03X02 = 06 Marks

6. What is the difference between primary windings and secondary winding in step up transformer? Explain it in terms of Magnetic flux.

Ans. **Transformers** have two **windings**, being the **primary winding** and the **secondary winding**. The **primary winding** is the **coil** that draws power from the source. The **secondary winding** is the **coil** that delivers the energy at the transformed or changed voltage to the load. In step up transformer no. of secondary winding are greater than primary windings as we know that no of magnetic field lines passes through particular cross section area is known as magnetic flux. As in secondary winding no of turns of coil is much more in step up transformer thus the change in magnetic flux will be more.

7. What do you mean by a piezo element? How a piezo crystal works?

Ans. Piezoelectricity is the electricity generated by **piezo element** by effect called the **piezoelectric** effect. It is the ability of certain materials to generate an AC (alternating current) voltage when subjected to mechanical stress or vibration, or to vibrate when subjected to an AC voltage.

Applying mechanical energy to a **crystal** is called a direct **piezoelectric** effect and **works** like this: A **piezoelectric crystal** is placed between two metal plates. ... Mechanical pressure is then applied to the material by the metal plates, which forces the electric charges within the **crystal** out of balance.

8. What do you mean by self-induction in a coil? Explain with the help of diagram.

Ans. **elf inductance** is defined as the **induction** of a voltage in a current-carrying wire when the current in the wire itself is changing. In the case of **self-inductance**, the magnetic field created by a changing current in the circuit itself induces a voltage in the



same circuit. Therefore, the voltage is **self-induced**

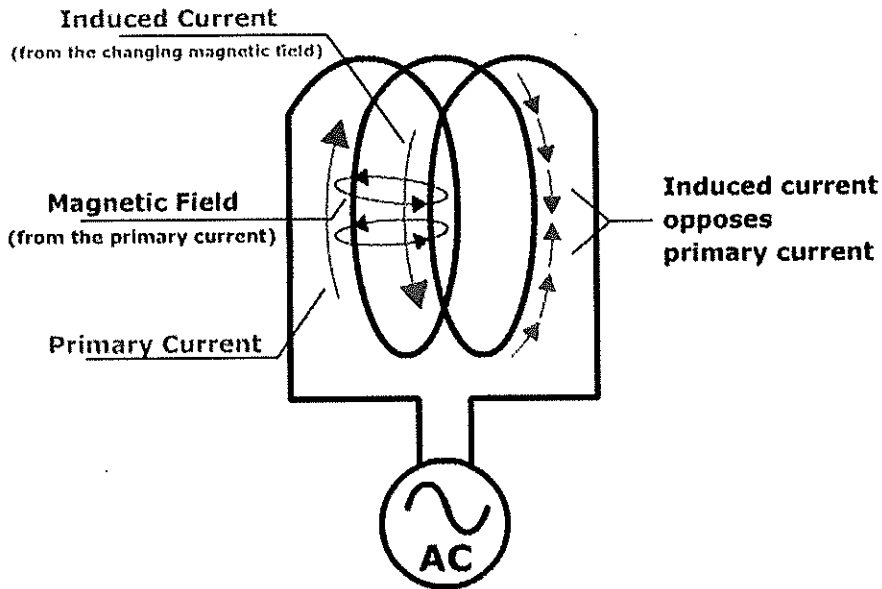

Section – C

03X03 = 09 Marks

9. Explain the working principle of a transistor in electronic circuits.

Ans. The fundamental **principle** behind all **transistors** is simple: Current flow between two terminals is prevented by an energy barrier that has been set up between them. To operate the **transistor**, a third terminal is provided that allows you to lower the energy barrier.

- Electron
- Hole

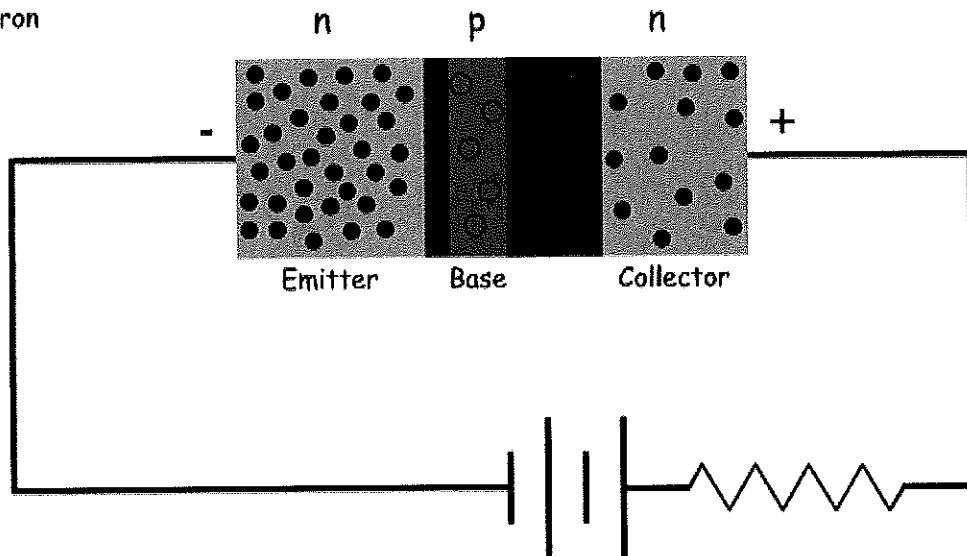

10. What is the difference between forward biased and reversed biased diodes? Draw the electronic symbol of an NPN transistor.

Ans. The **Forward bias** decreases the resistance of the diode whereas the **reversed bias** increases the resistance of the diode. In **forward biasing** the current is easily

flowing through the circuit whereas reverse bias does not allow the current to flow

Forward bias	Reverse bias
Positive terminal of battery is connected to <i>p</i> -type and negative terminal to <i>n</i> -type semiconductor.	Positive terminal of battery connected to <i>n</i> -type and negative terminal to <i>p</i> -type semiconductor.
Depletion layer is very thin.	Depletion layer is thick.
<i>p-n</i> junction offers very low resistance.	<i>p-n</i> junction offers very high resistance.
An ideal diode have zero resistance.	An ideal diode have infinite resistance.

through it.

11. Explain the process of current flow in an electrochemical cell.

Ans. The metal electrodes are immersed in electrolyte solutions. Each half-cell is connected by a salt bridge, which allows for the free transport of ionic species between the two cells. When the circuit is complete, the **current flows** and the cell "produces"

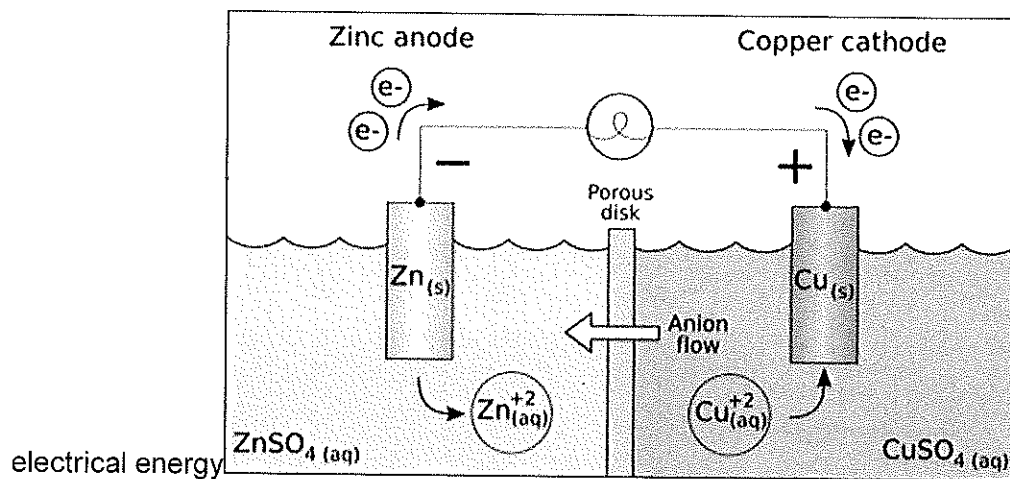

**School of Automotive Skills**  
**Session: 2019-20 (Summer Semester)**  
**B. Voc. Program, 3<sup>rd</sup> Semester,**  
**2<sup>nd</sup> In-Sem. Examination**

**Course Code: GEN 1305**

**Time: 1 Hour**

**Course Name: Elementary Drawing**

**Max. Marks: 20**

**Instruction:**

1. Answer all questions from section – A, each question carries one mark.
2. Answer all questions from section – B, each question carries two marks.
3. Answer all questions from section – C, each question carries three marks.

**Section – A**

05X01 = 05 Marks

Q 1. Which view is supposed to contain maximum information of the object in any projection method?

- |              |                 |
|--------------|-----------------|
| A. Top view  | C. Front view   |
| B. Side view | D. Section view |

Q 2. Short-break lines are drawn freehand while long-break lines are ruled lines.

- A. True  
B. False

Q 3. Which kind of sectional view is being shown in the given image?

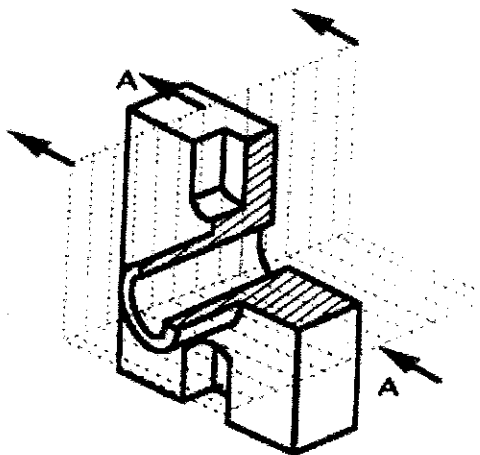

- |                      |                        |
|----------------------|------------------------|
| a) Full section view | c) Offset section view |
| b) Half section view | d) Broken section view |

Q 4. \_\_\_\_\_ is used to draw curves which are not circular.

- A. Compass
- B. Protractor
- C. French curves
- D. Pro circle

Q 5. The sizes of drawing board from D0 to D3 increases.

- A. True
- B. False

### Section – B

03X02 = 06 Marks

- Q 6. What is a technical drawing? What are the elements of engineering drawing?
- Q 7. Why engineers do not follow second angle and fourth angle projection method?
- Q 8. What are the application of mini drafter & set squares in engineering drawing?

### Section – C

03X03 = 09 Marks

Q 9. Draw the Front view, left side view and top view of the given object.

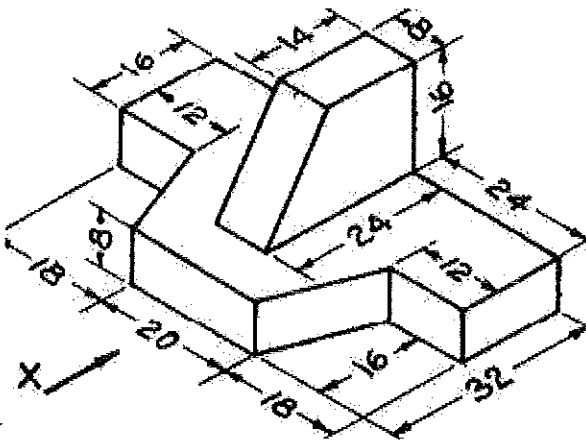

Q 10. Draw the symbol of first angle and third angle Projection having  $D=20$  mm.

Q 11. Explain 5 types of section views in engineering drawing with example. Explain the need of section views in engineering drawing.

**School of Automotive Skills**  
**Session: 2019-20 (Summer Semester)**  
**B. Voc. Program, 3<sup>rd</sup> Semester,**  
**2<sup>nd</sup> In-Sem. Examination**

**Course Code: GEN 1305**

**Time: 1 Hour**

**Course Name: Elementary Drawing**

**Max. Marks: 20**

**Instruction:**

1. Answer all questions from section – A, each question carries one mark.
2. Answer all questions from section – B, each question carries two marks.
3. Answer all questions from section – C, each question carries three marks.

**Section – A**

05X01 = 05 Marks

Q 1. Which view is supposed to contain maximum information of the object in any projection method?

- |              |                 |
|--------------|-----------------|
| A. Top view  | C. Front view   |
| B. Side view | D. Section view |

Q 2. Short-break lines are drawn freehand while long-break lines are ruled lines.

- A. True  
B. False

Q 3. Which kind of sectional view is being shown in the given image?

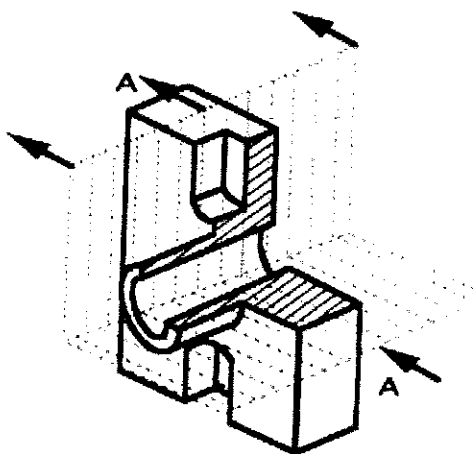

- |                      |                        |
|----------------------|------------------------|
| a) Full section view | c) Offset section view |
| b) Half section view | d) Broken section view |

Q 4. \_\_\_\_\_ is used to draw curves which are not circular.

- |               |                  |
|---------------|------------------|
| A. Compass    | C. French curves |
| B. Protractor | D. Pro circle    |

Q 5. The sizes of drawing board from D0 to D3 increases.

- A. True  
B. False

### Section – B

03X02 = 06 Marks

Q 6. What is a technical drawing? What are the elements of engineering drawing?

Ans. **Engineering drawings** are usually created in accordance with standardized conventions for layout, nomenclature, interpretation, appearance (such as typefaces and line styles), size, etc. Its purpose is to accurately and unambiguously capture all the geometric features of a product or a component.

Engineering drawing are made up of **graphics language** and **word language**.

- Describe a shape (mainly).
- Describe size, location and specification of the object.

Q 7. Why engineers do not follow second angle and fourth angle projection method?

Ans. Second angle and fourth angle projection method is not used in technical drawing because of overlapping of their front view, top view and side views on each other. It makes the drawing more complicated to read and understand all the facts and information of the object

Q 8. What are the application of mini drafter & set squares in engineering drawing?

Ans. **Mini drafter** is an instrument which can be used for multiple functions in drawing. It contains two arms which is adjustable to required angle and at the end of the lower arm a scale **set** is attached. The scale **set** contains two scales connected perpendicular to each which cannot be separated.

set square or triangle (American English) is an object used in engineering and technical ... These **set squares** come in two usual forms, both right triangles: one with 90-45-45 degree angles, the other with 30-60-90 degree angles.

Section – C

03X03 = 09 Marks

Q 9. Draw the Front view, left side view and top view of the given object.

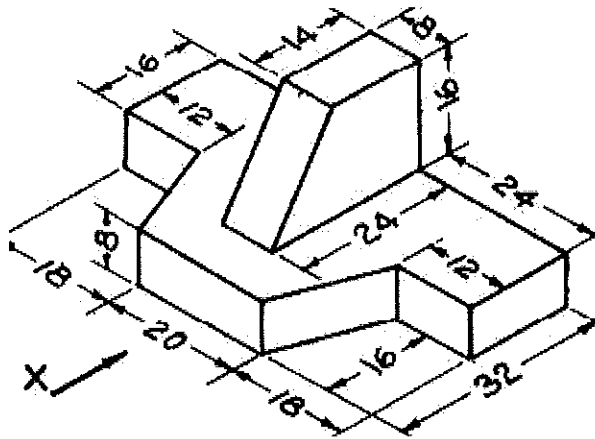

Q 10. Draw the symbol of first angle and third angle Projection having  $D=20$  mm.

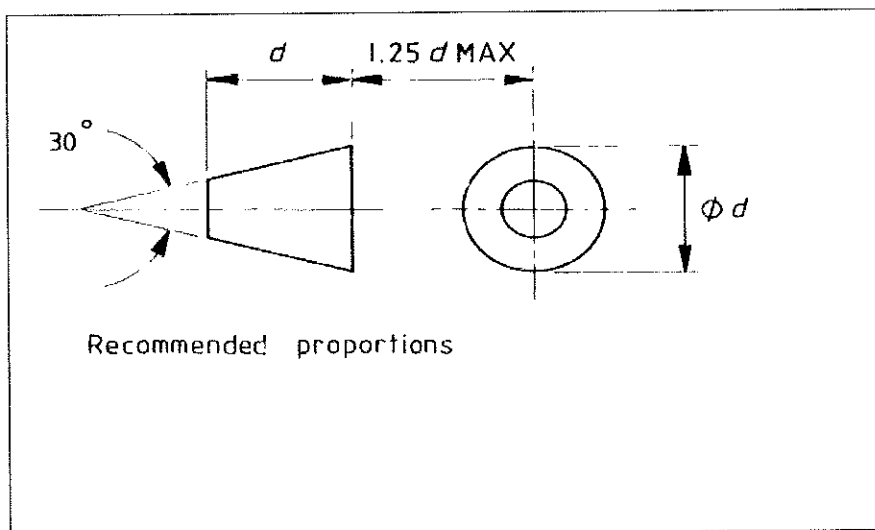

Q 11. Explain 5 types of section views in engineering drawing with example. Explain the need of section views in engineering drawing.

Ans.

1. Ans. Full Section View

- In this Cutting plane line passes fully through the part.

## 2. Offset Section View

- Used to show parts and features that do not line up with each other.
- Cutting-plane line does not travel in a straight line.

## 3. Half Section View

- Half Section is used to show the exterior and interior of the part in the same view.
- This is done with symmetrical parts.

## 4. Broken Section View

- Removes a small amount of material to show the interior details.
- Used to enhance the orthographic view by giving the viewer a better look at key interior details.

## 5. Revolved Section View

- Used to show a small portion of a drawing.
- Shows a cross-section of an area turned perpendicular to the object.



