



School of Automotive skills
Session: 2020-21 (Summer Semester)
B. Voc. Program, 1st Semester,
End-Sem. Examination

Course Code: AUT1101

Time: 2 Hours

Course Name: Automotive Power Train, Chassis & Suspension

Max. Marks: 50

Instruction:

1. Answer all questions from section – A, each question carries one mark.
2. Answer all questions from section – B, each question carries Four marks.
3. Answer all questions from section – C, each question carries Six marks.

Section – A

10X01 = 10 Marks

1. The main function of intake manifold is to:
 - a) Promotes the mixture of air and fuel
 - b) Reduces intake noise
 - c) Cools the intake air to a suitable temperature
 - d) Distributes intake air equally to the cylinders
2. The inside diameter of cylinder is called:
 - a) Stroke
 - b) Radius
 - c) Bore
 - d) All of the above
3. The petrol engines are also known as:
 - a) Spark ignition (S.I) engines
 - b) Compression ignition (C.I) engines
 - c) Steam engines
 - d) None of the above.
4. The correct flow of power through a drive train is:
 - a) Engine- gearbox- clutch- differential- propeller shaft- axle- wheels.
 - b) Engine- propeller shaft- gearbox- axle- clutch- differential- wheels
 - c) Engine- clutch- gearbox- propeller shaft- axle- differential, wheels
 - d) Engine- clutch- gearbox- propeller shaft- differential- axle- wheels.
5. The petrol engine works on:
 - a) Otto cycle
 - b) Diesel cycle
 - c) Carnot cycle
 - d) Rankine cycle

6. The connecting rod is connected to the piston by...
- a) Cap bolt
 - b) Gudgeon pin
 - c) Ball bearing
 - d) Screw
7. In a petrol engine, the function of a spark plug is to:
- a) Mix the air and fuel
 - b) Ignite the air-fuel mixture
 - c) Spray atomized fuel in the cylinder
 - d) Provide flame for ignition
8. Which one is not a part of disk brake?
- a) Drum
 - b) Caliper
 - c) Brake pad
 - d) cylinder
9. The purpose of break bleeding is to...
- a) Remove the air from pipeline
 - b) Fill the brake fluid in the pipeline
 - c) Both a & b
 - d) Repair the pipeline
10. A gear assembly, which converts the rotational motion into linear motion is called...
- a) Spur gear
 - b) Helical gear
 - c) Rack & pinion
 - d) Worm gear

Section – B

04X04 = 16 Marks

1. Write any six differences between 2-stroke and 4- stroke petrol engine.
2. What is the suspension system? Explain the function of suspension system.
3. Explain the four-wheel drive vehicle with the help of a diagram.
4. What are the various safety practices that must be followed in an automobile workshop?

Section – C

04X06 = 24 Marks

5. What is ABS? Explain its components.
6. What is clutch? Explain single plate and multi-plate clutch system.
7. Draw the PV diagram of otto and diesel cycle.
8. Write short notes on:
 - a. 2-stroke engine
 - b. Universal joint
 - c. Differential

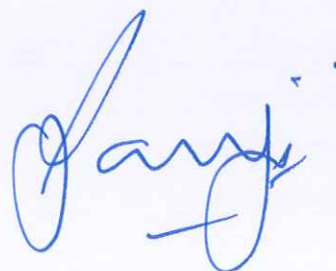



School of Automotive skills
Session: 2020-21 (Summer Semester)
B. Voc. Program, 1st Semester,
End-Sem. Examination

Answer key

Course Code: AUT1101

Time: 2 Hours

Course Name: Automotive Power Train, Chassis & Suspension

Max. Marks: 50

Instruction:

1. Answer all questions from section – A, each question carries one mark.
2. Answer all questions from section – B, each question carries Four marks.
3. Answer all questions from section – C, each question carries Six marks.

Section – A

10X01 = 10 Marks

1. The main function of intake manifold is to:
 - a) Promotes the mixture of air and fuel
 - b) Reduces intake noise
 - c) Cools the intake air to a suitable temperature
 - d) Distributes intake air equally to the cylinders
2. The inside diameter of cylinder is called:
 - a) Stroke
 - b) Radius
 - c) Bore
 - d) All of the above
3. The petrol engines are also known as:
 - a) Spark ignition (S.I) engines
 - b) Compression ignition (C.I) engines
 - c) Steam engines
 - d) None of the above.
4. The correct flow of power through a drive train is:
 - a) Engine- gearbox- clutch- differential- propeller shaft- axle- wheels.
 - b) Engine- propeller shaft- gearbox- axle- clutch- differential- wheels
 - c) Engine- clutch- gearbox- propeller shaft- axle- differential, wheels
 - d) Engine- clutch- gearbox- propeller shaft- differential- axle- wheels.
5. The petrol engine works on:
 - a) Otto cycle
 - b) Diesel cycle
 - c) Carnot cycle
 - d) Rankine cycle

6. The connecting rod is connected to the piston by...
 - a) Cap bolt
 - b) **Gudgeon pin**
 - c) Ball bearing
 - d) Screw
7. In a petrol engine, the function of a spark plug is to:
 - a) Mix the air and fuel
 - b) **Ignite the air-fuel mixture**
 - c) Spray atomized fuel in the cylinder
 - d) Provide flame for ignition
8. Which one is not a part of disk brake?
 - a) **Drum**
 - b) Caliper
 - c) Brake pad
 - d) cylinder
9. The purpose of break bleeding is to...
 - a) Remove the air from pipeline
 - b) Fill the brake fluid in the pipeline
 - c) **Both a & b**
 - d) Repair the pipeline
10. A gear assembly, which converts the rotational motion into linear motion is called...
 - a) Spur gear
 - b) Helical gear
 - c) **Rack & pinion**
 - d) Worm gear

Section – B

04X04 = 16 Marks

1. Write any six differences between 2-stroke and 4- stroke petrol engine.

Ans.

S.No.	Two stroke Engine	Four stroke Engine
1.	When the cycle is completed in one revolution of crankshaft, it is called as 2-stroke cycle engine.	When the cycle is completed in two revolutions of crankshaft, it is called as 4-stroke cycle engine.
2.	One power stroke for each revolution of the crankshaft.	One power stroke for every two revolutions of the crankshaft.
3.	There are inlet and exhaust ports in the engine.	There are inlet and exhaust valves in the engine.
4.	Size of the flywheel is comparatively smaller.	Size of the flywheel is comparatively larger.
5.	Removal of exhaust gases comparatively difficult.	Removal of exhaust gases easy
6.	Mostly high speed engines are in this type.	All speed types are possible.

2. What is the suspension system? Explain the function of suspension system.

- Ans. Any system used in vehicle to reduce road shocks and vibration known as suspension system. Springs, shock absorber torsion bar etc. are components of

suspension system. Suspension system also provide the vehicle stability in running condition.

- The main work of suspension system is to isolate the vehicle and the passenger to the road shock and vibration so that the passengers will enjoy a comfortable ride.

3. Explain the four-wheel drive vehicle with the help of a diagram.

Ans.

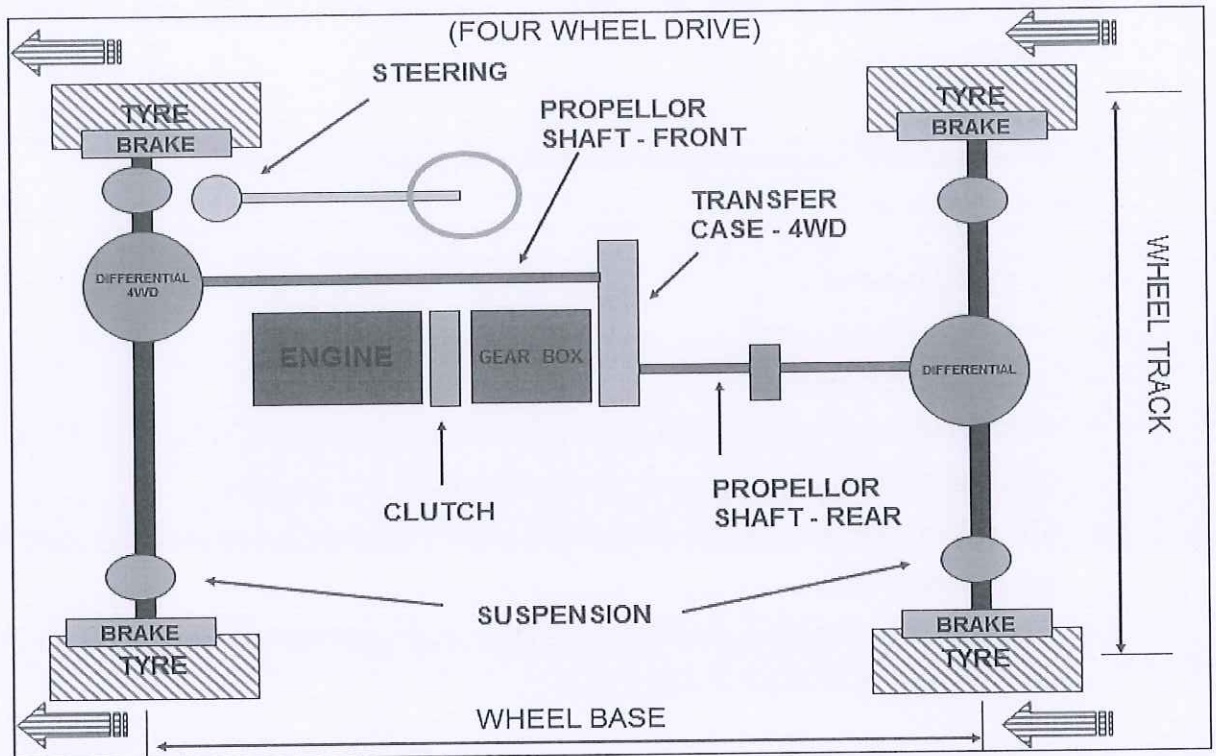

4. What are the various safety practices that must be followed in an automobile workshop?

Ans: The various safety practices are as follows:

- Always wear a safety helmet in the workshop, especially when working under the vehicle.
- Wear cotton hand gloves when working or carrying out repairs or service on a vehicle.
- Wear face masks to cover your nose and mouth.
- Wear safety goggles when working under the vehicle.
- Do not wear rings, watches and loose clothes when working on a vehicle.
- Keep the shop floor clean and tidy.
- Wear safety shoes in the workshop.
- Use specific and tool for a specific job.

5. What is ABS? Explain its components.

- Ans. An anti-lock braking system or anti-skid braking system (ABS) is an automobile safety system that allows the wheels on a motor vehicle to maintain tractive contact with the road surface according to driver inputs while braking, preventing the wheels from locking up (ceasing rotation) and avoiding uncontrolled skidding.
- ABS generally offers improved vehicle control and decreases stopping distances on dry and slippery surfaces; however, on loose gravel or snow-covered surfaces, ABS can significantly increase braking distance, although still improving vehicle steering control.

6. What is clutch? Explain single plate and multi-plate clutch system.

Ans. It consists of

- a driving member,
 - a driven member, and
 - an operating member.
- Driving member has a flywheel which is mounted on the engine crankshaft. A disc is bolted to flywheel which is known as pressure plate or driving disc.
 - The driven member is a disc called clutch plate. This plate can slide freely to and fro on the clutch shaft.
 - The operating member consists of a pedal or lever which can be pressed to disengage the driving and driven plate.

7. Draw the PV diagram of otto and diesel cycle.

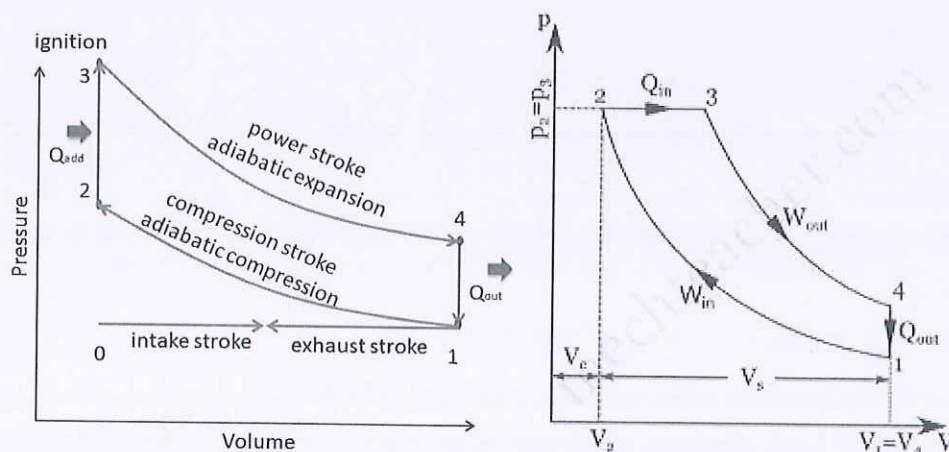

8. Write short notes on:

- a. 2-stroke engine
- b. Universal joint
- c. Differential

- Ans. Universal joint is also known as cardan joint and U joint.

- This joint is the point of connection in a stiff rod which enables the rod to turn in any desired direction in auto transmission system.
- In other words universal joint is a joining link between two shafts that are in a changing position.
- These automotive transmission parts are one of the earliest form of flexible couplings that have two shaft yokes located at 90 degrees angle to each other and a four point cross that fasten the yokes.

School of Automotive skills
Session: 2020-21 (Summer Semester)
B. Voc. Program, 1st Semester, *Set B*
End-Sem. Examination

Course Code: AUT1101

Time: 2 Hours

Course Name: Automotive Power Train, Chassis & Suspension

Max. Marks: 50

Instruction:

1. Answer all questions from section – A, each question carries One mark.
2. Answer all questions from section – B, each question carries Four marks.
3. Answer all questions from section – C, each question carries Six marks.

Section – A

10X01 = 10 Marks

1. Full form of ECU is...
 - a) Engine control unit
 - b) Electronic connection unit
 - c) Electrical control unit
 - d) Electric connection unit
2. When piston is at the top, the volume contained in the cylinder above the top of the piston is called...
 - a) Swept volume
 - b) Clearance volume
 - c) Total cylinder volume
 - d) None of these
3. Hydraulic braking system works on the principle of...
 - a) Pascal's law
 - b) Gas law
 - c) Both a & b
 - d) None of the above.
4. The correct flow of power through a drive train is:
 - a) Engine- gearbox- clutch- differential- propeller shaft- axle- wheels.
 - b) Engine- propeller shaft- gearbox- axle- clutch- differential- wheels
 - c) Engine- clutch- gearbox- propeller shaft- axle- differential, wheels
 - d) Engine- clutch- gearbox- propeller shaft- differential- axle- wheels.
5. Which one is not a part of Drum brake system?
 - a) Cylinder
 - b) Brake pad
 - c) Caliper
 - d) All of the above
6. In a stroke engine the working cycle completes in...
 - a) One revolution of crankshaft
 - b) Two revolution of crankshaft
 - c) three revolution of crankshaft
 - d) All of the above

7. In a diesel engine, the function of a fuel injector is to:
 - a) Mix the air and fuel
 - b) Ignite the air-fuel mixture
 - c) Spray atomized fuel in the cylinder
 - d) Provide flame for ignition
8. The motion of the camshaft is transferred to the valves through...
 - a) Rocker arm
 - b) Piston
 - c) Spring
 - d) Bearing
9. The purpose of break bleeding is to...
 - a) Remove the air from pipeline
 - b) Fill the brake fluid in the pipeline
 - c) Both a & b
 - d) Repair the pipeline
10. Full form of CI engine is...
 - a) Combustion ignition engine
 - b) Controlled ignition engine
 - c) Compression ignition engine
 - d) None of these

Section – B

04X04 = 16 Marks

1. Write down different parts of suspension system.
2. Write any six differences between 2-stroke and 4- stroke petrol engine.
3. Explain hydraulic braking system.
4. Define IC engine? Explain the working of otto cycle.

Section – C

04X06 = 24 Marks

5. Explain the process of general service of a vehicle?
6. Explain Suspension system of a vehicle.
7. Explain All wheel drive vehicle with the help of a diagram.
8. Explain disc brake system and its components.

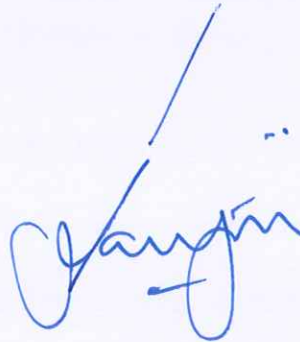

School of Automotive skills
Session: 2020-21 (Summer Semester)
B. Voc. Program, 1st Semester,
End-Sem. Examination

Answer key
Set B

Course Code: AUT1101

Time: 2 Hours

Course Name: Automotive Power Train, Chassis & Suspension

Max. Marks: 50

Instruction:

1. Answer all questions from section – A, each question carries One mark.
2. Answer all questions from section – B, each question carries Four marks.
3. Answer all questions from section – C, each question carries Six marks.

Section – A

10X01 = 10 Marks

1. Full form of ECU is...
 - a) Engine control unit
 - b) Electronic connection unit
 - c) Electrical control unit
 - d) Electric connection unit
2. When piston is at the top, the volume contained in the cylinder above the top of the piston is called...
 - a) Swept volume
 - b) Clearance volume
 - c) Total cylinder volume
 - d) None of these
3. Hydraulic braking system works on the principle of...
 - a) Pascal's law
 - b) Gas law
 - c) Both a & b
 - d) None of the above.
4. The correct flow of power through a drive train is:
 - a) Engine- gearbox- clutch- differential- propeller shaft- axle- wheels.
 - b) Engine- propeller shaft- gearbox- axle- clutch- differential- wheels
 - c) Engine- clutch- gearbox- propeller shaft- axle- differential, wheels
 - d) Engine- clutch- gearbox- propeller shaft- differential- axle- wheels.
5. Which one is not a part of Drum brake system?
 - a) Cylinder
 - b) Brake pad
 - c) Caliper
 - d) All of the above
6. In two stroke engine the working cycle completes in...
 - a) One revolution of crankshaft
 - b) Two revolution of crankshaft
 - c) three revolution of crankshaft
 - d) All of the above

7. In a diesel engine, the function of a fuel injector is to:
 - a) Mix the air and fuel
 - b) Ignite the air-fuel mixture
 - c) Spray atomized fuel in the cylinder
 - d) Provide flame for ignition
8. The motion of the camshaft is transferred to the valves through...
 - a) Rocker arm
 - b) Piston
 - c) Spring
 - d) Bearing
9. The purpose of break bleeding is to...
 - a) Remove the air from pipeline
 - b) Fill the brake fluid in the pipeline
 - c) Both a & b
 - d) Repair the pipeline
10. Full form of CI engine is...
 - a) Combustion ignition engine
 - b) Controlled ignition engine
 - c) Compression ignition engine
 - d) None of these

Section – B

04X04 = 16 Marks

1. Write down different parts of suspension system.

Ans. **Control arm:** In automotive suspensions, a **suspension link, control link** or link is a suspension member, that attaches at only two points. One point being the body or frame of the vehicle and the other point attaching to the knuckle, upright, axle or another link. The link pivots on either a bushing or a ball joint at each attachment point. A link differs from a control arm because it can only control one of the degrees of freedom by itself.

- **Steering knuckle:** It provides a spindle or bearing support for the wheel hub, bearing and assembly.

2. Write any six differences between 2-stroke and 4- stroke petrol engine.

Ans.

S.No.	Two stroke Engine	Four stroke Engine
1.	When the cycle is completed in one revolution of crankshaft, it is called as 2-stroke cycle engine.	When the cycle is completed in two revolutions of crankshaft, it is called as 4-stroke cycle engine.
2.	One power stroke for each revolution of the crankshaft.	One power stroke for every two revolutions of the crankshaft.
3.	There are inlet and exhaust ports in the engine.	There are inlet and exhaust valves in the engine.
4.	Size of the flywheel is comparatively smaller.	Size of the flywheel is comparatively larger.

5.	Removal of exhaust gases comparatively difficult.	Removal of exhaust gases easy
6.	Mostly high speed engines are in this type.	All speed types are possible.

3. Explain hydraulic braking system.

- Ans. Hydraulic Braking System is the System Which used Hydraulic Fluid to build up the pressure for Braking Action.
- Hydraulic Braking System is the System Which used Hydraulic Fluid to build up the pressure for Braking Action.

4. Define IC engine? Explain the working of otto cycle.

IC engine: internal combustion engine

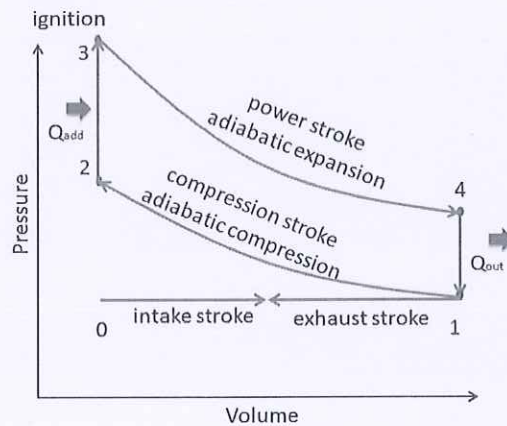

Section – C

04X06 = 24 Marks

5. Explain the process of general service of a vehicle?

Ans The engine service includes:

- Engine oil change
- Oil filter /Air filter change
- Cooling system maintenance
- Spark plug/fuel injector check
- Timing chain service
- Sealing /gasket check
- Internal parts like piston rings, bearings, and valve train components check
- Engine removal and installation.

6. Explain Suspension system of a vehicle.

Ans. **Control arm:** In automotive suspensions, a **suspension link**, **control link** or link is a suspension member, that attaches at only two points. One point being the body or frame of the vehicle and the other point attaching to the knuckle, upright, axle or another link. The link pivots on either a bushing or a ball joint at each attachment point. A link differs from a control arm because it can only control one of the degrees of freedom by itself.

- **Steering knuckle:** It provides a spindle or bearing support for the wheel hub, bearing and assembly.

7. Explain All wheel drive vehicle with the help of a diagram.

Ans

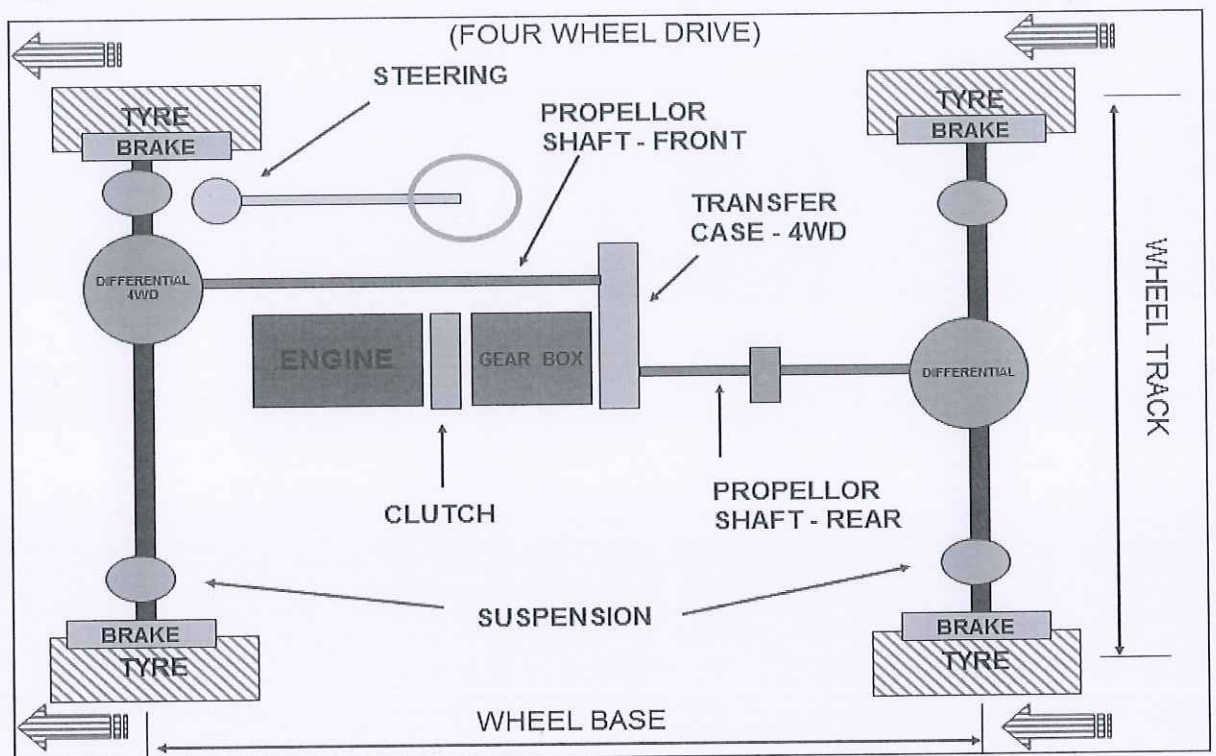

8. Explain disc brake system and its components

Ans. A disc brake is a type of brake that uses calipers to squeeze pairs of pads against a rotor (or "disc") in order to create friction that retards the rotation of a shaft, such as a vehicle axle, either to reduce its rotational speed or to hold it stationary.



School of Automotive Skills
Session: 2020-21 (Summer Semester)
B. Voc. Program, 1st Semester,
End-Sem. Examination

Set A

Course Code: AUT1102

Time: 2 Hours

Course Name: Automotive Wheel Care & Steering System

Max. Marks: 50

Instruction:

1. Answer all questions from section – A, each question carries one mark.
2. Attempt all questions from section – B, each question carries four marks.
3. Answer all questions from section – C, each question carries six marks.

Section – A

10X01 = 10 Marks

Q1. The main function of steering pump is:

- a. To provide force.
- b. To provide pressure.
- c. To provide torque.
- d. To provide load.

Q2. What is the best temperature to use summer tyre?

- a. Below +8°C.
- b. Above + 8°C.
- c. Above +7°C.
- d. Below +7°C.

Q3. The purpose of wheel axle in a vehicle is:

- a. To cool the engine.
- b. To give power on fly-wheel.
- c. To give structural support to wheels.
- d. For air intake.

Q4. The function of the _____ is to enhance the performance and provide better steering and vehicle stability.

- a. Groove.
- b. Pitch.
- c. Rain type.
- d. None of the above.

Q5. Where is the bead located in the tyre?

- a. At surface.
- b. On edges.
- c. On side walls.
- d. Inner side.

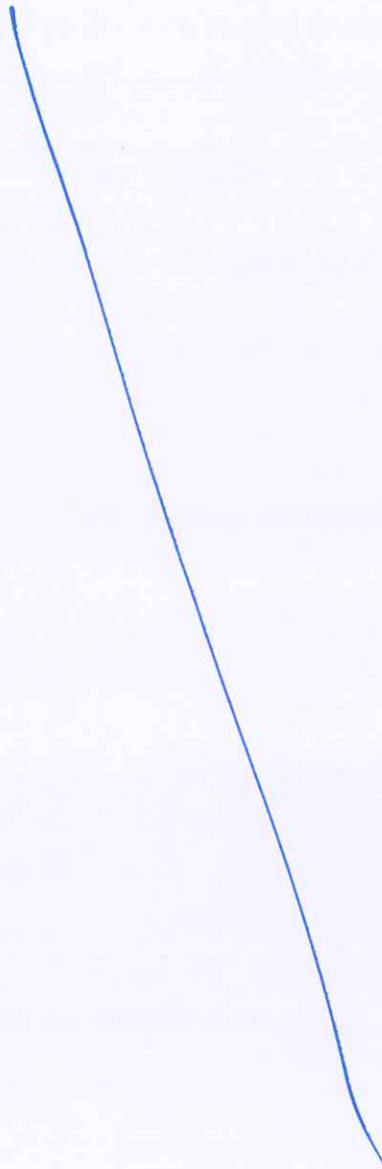



Q6. What is the full form of TPMS?

- a. Tyre Pressure Monitoring Sensor.
- b. Tyre Pressure Maintenance Sensor.
- c. Tyre Pressure Master Cylinder.
- d. Tyre Puncture Management Sensor.

Q7. What is the full form of TWI?

- a. Tread wear indicator.
- b. Tyre wear indicator.
- c. Tread worn indicator.
- d. Tyre worn indicator.

Q8. Date of manufacturing on a tyre is given as:

- a. 13-5-2018.
- b. 13/05/2018.
- c. 1318.
- d. 13/18.

Q9. What is the unit used to measure tyre width of a tyre?

- a. Inch.
- b. Percent.
- c. Millimeter.
- d. Degree.

Q10. What is Gerotor?

- a. Negative displacement pump.
- b. Positive displacement pump.
- c. All of the above.
- d. None of the above.

Section – B

04X04 = 16 Marks

Q11. Write briefly about requirement of a good steering system.

Q12. What are the steps involved to ensure accurate wheel alignment measurement?

Q13. Write down the process of wheel bearing maintenance.

Q14. What are the safety equipment used in wheel care section?

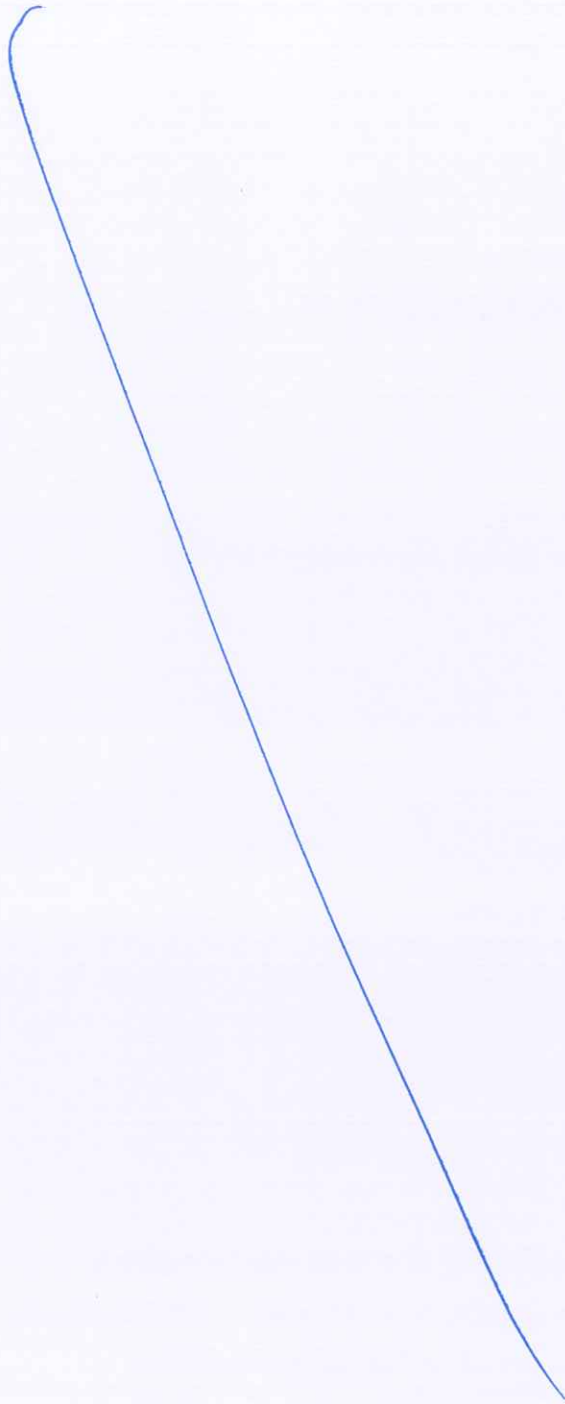

10

Section – C

04X06 = 24 Marks

- Q15. Explain the role & responsibilities of a wheel care technician in an automotive workshop.
Q16. Identify the components of tyre changer in the figure given below:

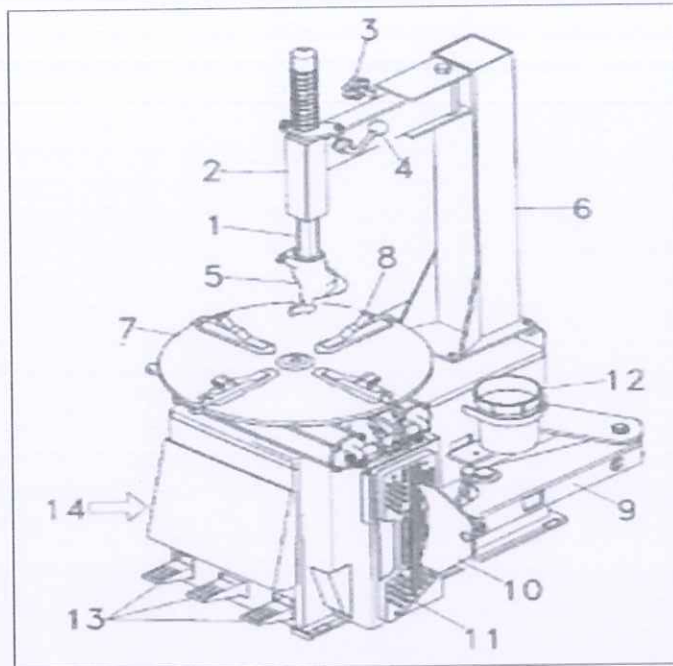

- Q17. Write different types of screwdrivers and explain them with diagrams.
Q18. Explain the components & working of a Hydraulic Power Steering System with the help of a diagram.

Handwritten signature



School of Automotive Skills
Session: 2020-21 (Summer Semester)
B. Voc. Program, 1st Semester,
End-Sem. Examination

Set-A
Answer Key

Course Code: AUT1102

Time: 2 Hours

Course Name: Automotive Wheel Care & Steering System

Max. Marks: 50

Section – A

10X01 = 10 Marks

Q1. The main function of steering pump is:

Answer: b. To provide pressure.

Q2. What is the best temperature to use summer tyre?

Answer: c. Above +7°C.

Q3. The purpose of wheel axle in a vehicle is:

Answer: c. To give structural support to wheels.

Q4. The function of the _____ is to enhance the performance and provide better steering and vehicle stability.

Answer: b. Pitch.

Q5. Where is the bead located in the tyre?

Answer: b. On edges.

Q6. What is the full form of TPMS?

Answer: a. Tyre Pressure Monitoring Sensor.

Q7. What is the full form of TWI?

Answer: a. Tread wear indicator.

Q8. Date of manufacturing on a tyre is given as:

Answer: 1318.

Q9. What is the unit used to measure tyre width of a tyre?

Answer: Inch.

Q10. What is Gerotor?

Answer: b. Positive Displacement Pump.



Q11. Write briefly about requirement of a good steering system.

Answer: Following are the requirements of a good steering system:

- a. Very accurate.
- b. Easy to handle.
- c. Provide directional stability.
- d. Multiply the turning effort applied on the steering wheel by the driver.
- e. Irreversible to a certain degree, so that the shocks of the road surface encountered by the wheels are not transmitted to driver's hands.

Q12. What are the steps involved to ensure accurate wheel alignment measurement?

Answer:

1. Centre the vehicle on the alignment rack.
2. Push down on the front and rear bumper three times.
3. Install the alignment heads to the vehicle.
4. Select the program on the alignment equipment.
5. Compensate, level, and lock all of the alignment equipment.
6. Measure caster, camber & toe angles and record the same.
7. Compare the measurements to the specifications mentioned in the service manual.
8. As per the specifications, adjust the below as required:
 - a. Adjust turning angle.
 - b. Adjust front and rear camber as per the specs mentioned.
 - c. Adjust the toe as the specs mentioned.
 - d. Lower the vehicle from the alignment rack.

Q13. Write down the process of wheel bearing maintenance.

Answer:

Step 1. Prepare the vehicle.

Step 2. Remove wheel and brake unit.

Step 3. Removing The Bearing Hub Assembly.

Remove the dust cap and remove the locking device. This is usually a cotter pin through the nut & spindle.

Step 4. Remove hub seal.

Using a long dowel pin or drift & using a hammer, gently drive on the front of the inner hub bearing from inside the hub unit.

Step 5. Clean and Check the Oil Bearing.

Use a paper towel to wipe all of the old bearing grease from the spindle and the hub dust cap.

Clean the bearing with solvent & air dry on a paper towel or blow it dry with compressed air.



Step 6. Inspect The Bearing.

Inspect the bearing and it's housing, which is called the "Bearing Race," for damage.

IF you see any pitting or damage, replace all the bearing set.

Step 7. Re-pack Grease into Bearing.

Check your shop manual to see which grease is recommended for the vehicle and its application. The most common method is to pack the bearings by hand.

Step 8. Grease Inside of the Hub and Dust Cap.

Put a small amount of grease in the cavity of the hub.

Also pack some grease into the dust cap. Fill it about one-third, not all the way up.

Step 9. Re-install The Bearing and Seal.

Re-install the bearing in the same bearing race. Leave a ring of grease below the bearing race to help keep the fresh grease inside the bearing area after it heats up.

Step 10. Inspect the Sealing Area of the Spindle.

Inspect the sealing area of any signs of wear or damage. If the seal area is worn or grooved.

Step 11. Re-install Bearing Hub Assembly.

Slide the hub assembly onto the spindle and ensure it site on the sealing area.

Put the outer bearing in place.

Q14. What are the safety equipment used in wheel care section?

Answer:

Safety glasses: If you are working in workshop, then you should always wear safety glasses. Because some time stones dust particles available on wheel and when wheel is rotating then it gone into your eyes so you must wear safety glasses with side protection.

Safety gloves: This type of glove can provide protection against some moderate concentrated chemicals. The risk of cuts and abrasions also can be minimized by wearing gloves.

Helmet: Helmet will protect the user's head against: impact from objects falling from above, by resisting and deflecting blows to the head

Safety shoes: A steel-toe boot is protective reinforcement in the toe which protects the foot from falling objects or compression, usually combined with a mid-sole plate to protect against punctures from below.

Section – C

04X06 = 24 Marks

Q15. Explain the role & responsibilities of a wheel care technician in an automotive workshop.

Answer:

- An automotive service technician (or auto mechanic) is someone who inspects, maintains, repair and replace like tyre brake etc.
- Test parts and systems to ensure they are working properly.
- Identify mechanical problems, often by using computerized diagnostic equipment.
- Follow checklists to ensure that all critical parts are examined.

- Perform basic care of tyre rotations.
- Repair or replace worn parts, such as brake pads and wheel bearings.
- Disassemble and reassemble parts.
- Use testing equipment to ensure that repairs and maintenance are effective.
- Explain to clients their automotive problems and the repairs done on their vehicles.

Q16. Identify the components of tyre changer in the figure given below:

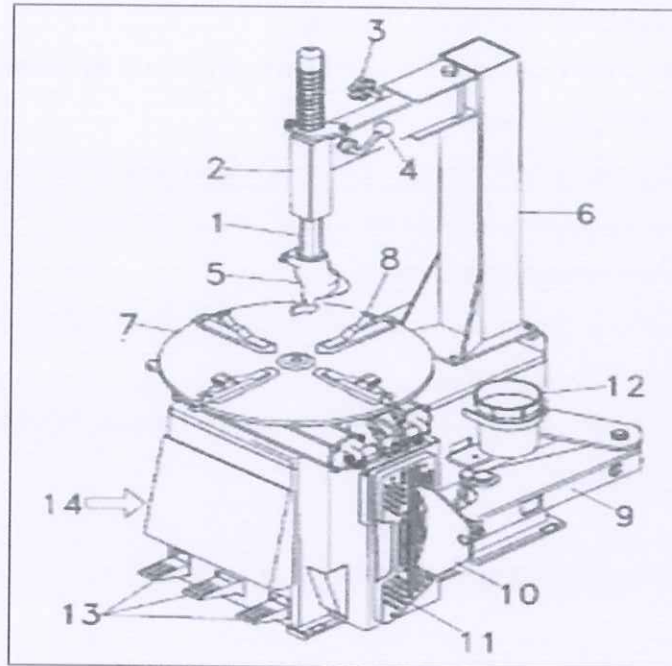

Answer:

1. Vertical slide.
2. Swing arm.
3. Adjustable knob.
4. Lock lever.
5. Mount / demount head.
6. Tower or column.
7. Turntable.
8. Jaw or clamp.
9. Bead breaker arm.
10. Bead breaker blade.
11. Bead breaker pads.
12. Lube pail.
13. Foot pedal controls.
14. Bead seater/ inflator pedal.

Q17. Write different types of screwdrivers and explain them with diagrams.

Answer:

1. Slot Head – This is one of the most common types because it is the easiest screw to make. For this reason, just about anything you find that was created during the error where screws were handmade will have a slot head screw. Most people call this a flat head screw or flat head screwdriver.
2. Phillips – Most people don't realize that a Phillips head screwdriver is designs for a specific task. It is designed to push the screwdriver out of the head when the screw is tight. That's why you have trouble getting one into some materials that are extremely tough.
3. Pozidrive – A Pozidrive screw looks a lot list a Phillips head screw, but does not push your screwdriver out when tight. You can apply as much torque as you need without running into any problems.
4. Hexagon – Hex screwdrivers are some of the simplest and cheap to produce. This is why you will see them used in a lot of furniture you purchase from discount stores. They are easy to use, but do not provide you any insurance that you won't tighten them too much.
5. Torx – Just like the name implies, this head is designed to give you the most torque possible. It is designed a lot like the hex screws but it is designed to have more contact between the screwdriver and the screw, so the torque is distributed more evenly.

Q18. Explain the components & working of a Hydraulic Power Steering System with the help of a diagram.

Answer:

In this system fluid pressure from the pump is used to push against a piston. When the wheel is turned, pressure flows to one side and the piston moves. The piston is attached to the **steering** gears. Hydraulic pressure does the **work**, and the driver controls the direction by turning the **steering** wheel.

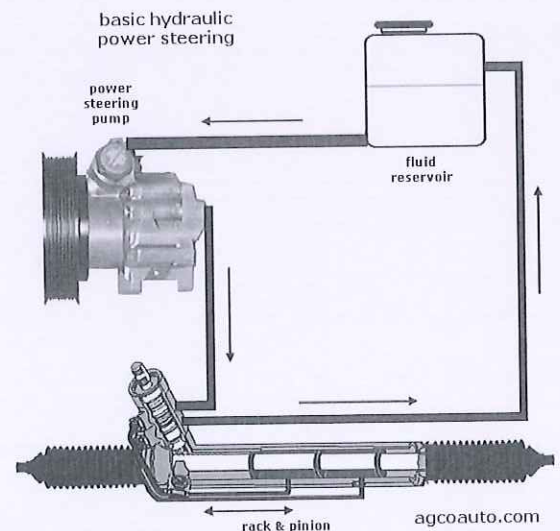



School of Automotive Skills

Session: 2020-21 (Summer Semester)

B. Voc. Program, 1st Semester,

End-Sem. Examination

Set-B

Course Code: AUT1102

Time: 2 Hours

Course Name: Automotive Wheel Care & Steering System

Max. Marks: 50

Instruction:

1. Answer all questions from section – A, each question carries one mark.
2. Attempt all questions from section – B, each question carries four marks.
3. Answer all questions from section – C, each question carries six marks.

Section – A

10X01 = 10 Marks

Q1. What is the main principle of wheel balancing?

- a. To balance the wheel anyway.
- b. To optimize and minimize the weight on wheel.
- c. To rotate the wheel unbalanced.
- d. All of the above.

Q2. What is the best temperature to use winter tyre?

- a. Below +8°C.
- b. Above + 8°C.
- c. Above +7°C.
- d. Below +7°C.

Q3. The purpose of tyre pressure inflator in an Automotive Workshop is:

- a. To clean the workshop.
- b. To fill any standard of air to the wheels.
- c. To inflate the required/standard pressure in PSI to the wheels.
- d. None of the above.

Q4. The function of the _____ is to enhance the performance and provide better steering and vehicle stability.

- a. Groove.
- b. Pitch.
- c. Rain type.
- d. None of the above.

Q5. Tyre size of a tyre is given as:

- a. 125.
- b. 125/50.
- c. 175/65 R15.
- d. None of the above.





Q6. What is the full form of TPMS?

- a. Tyre Pressure Monitoring Sensor.
- b. Tyre Pressure Maintenance Sensor.
- c. Tyre Pressure Master Cylinder.
- d. Tyre Puncture Management Sensor.

Q7. The collection of components, linkages, etc. which allows any vehicle to follow the desired course is known as:

- a. Suspension System.
- b. Steering System.
- c. Braking System.
- d. All of the above.

Q8. Date of manufacturing on a tyre is given as:

- e. 13-5-2018.
- f. 13/05/2018.
- g. 1318.
- h. 13/18.

Q9. What is the unit used to measure tyre width of a tyre?

- a. Inch.
- b. Percent.
- c. Millimeter.
- d. Degree.

Q10. What is the full form of TWI?

- a. Tread wear indicator.
- b. Tyre wear indicator.
- c. Tread worn indicator.
- d. Tyre worn indicator.

Section – B

04X04 = 16 Marks

Q11. What are key factors which can define that your vehicle has a good steering system?

Q12. What are the steps involved to ensure accurate wheel balancing?

Q13. Write a short note on:

- a. Aspect Ratio.
- b. Load Index.

Q14. What are the differences between tools and equipment used in the wheel care department?



Section – C

04X06 = 24 Marks

Q15. What are the possible reasons of experiencing vibrations on steering wheel, particularly driving at high speeds? How this problem can be resolved? Explain the steps in detail.

Q16. Explain the classification of tyres based on season and application.

Q17. Define Camber, Castor & Toe angles of wheel geometry.

Q18. Explain the components & working of an Electric Power Assisted Steering System with the help of a diagram.



School of Automotive Skills
Session: 2020-21 (Summer Semester)
B. Voc. Program, 1st Semester,
End-Sem. Examination

Course Code: AUT1102

Time: 2 Hours

Course Name: Automotive Wheel Care & Steering System

Max. Marks: 50

Section – A

10X01 = 10 Marks

Q1. What is the main principle of wheel balancing?

Answer: b. To optimize and minimize the weight on wheel.

Q2. What is the best temperature to use winter tyre?

Answer: d. Below +7°C.

Q3. The purpose of tyre pressure inflator in an Automotive Workshop is:

Answer: c. To inflate the required/standard pressure in PSI to the wheels.

Q4. The function of the _____ is to enhance the performance and provide better steering and vehicle stability.

Answer: b. Pitch.

Q5. Tyre size of a tyre is given as:

Answer: c. 175/65 R15.

Q6. What is the full form of TPMS?

Answer: a. Tyre Pressure Monitoring Sensor.

Q7. The collection of components, linkages, etc. which allows any vehicle to follow the desired course is known as:

Answer: b. Steering System.

Q8. Date of manufacturing on a tyre is given as:

Answer: c. 1318.

Q9. What is the unit used to measure tyre width of a tyre?

Answer: a. Inch.

Q10. What is the full form of TWI?

Answer: a. Tread wear indicator.



Section – B

04X04 = 16 Marks

Q11. What are key factors which can define that your vehicle has a good steering system?

Answer: Following are the requirements of a good steering system:

- a. Very accurate.
- b. Easy to handle.
- c. Provide directional stability.
- d. Multiply the turning effort applied on the steering wheel by the driver.
- e. Irreversible to a certain degree, so that the shocks of the road surface encountered by the wheels are not transmitted to driver's hands.

Q12. What are the steps involved to ensure accurate wheel balancing?

Answer:

- a. Standard tyre air pressure.
- b. Cleaned wheel for balancing.
- c. Old weights should be removed.
- d. Proper setup of equipment is required.
- e. Optimize and minimize operation should be performed.
- f. Re-checking of the balancing after counter weight installation is mandatory.

Q13. Write a short note on:

- a. Aspect Ratio.
- b. Load Index.

Answer:

Aspect Ratio

The fourth and fifth digits of the tyre code that immediately follow the tyre width. So an aspect ratio of 55 for example means that the profile height of the tyre is 55% of its width.

Load Index

The load index provides information on the maximum weight capability for the tyre. The load index is a numerical code that can be located just after the tyre size marking and before the speed rating.

Q14. What are the differences between tools and equipment used in the wheel care department?

Answer:

Sr. No.	Tools	Equipment
1	A tool can be any item that is used to achieve a goal	Equipment usually denotes a set of tools that are used to achieve a specific objective



2

A tool can be non-mechanical device

A equipment is a mechanical device

3

The usage of tools among human beings runs back to millions of years

The use of equipment is more of a recent development.

4

Tools are often seen to be used by animals

Equipment is only used by human beings.

Section – C

04X06 = 24 Marks

Q15. What are the possible reasons of experiencing vibrations on steering wheel, particularly driving at high speeds? How this problem can be resolved? Explain the steps in detail.

Answer:

Step 1: Put safety first.

Before you can begin to do anything, make sure you are protected by wearing some safety equipment. Make sure you are wearing steel toes boots, long pants, safety glasses or goggles, and gloves.

Step 2: Ensure you have proper tires.

Make sure the tyres that you have on the rims are good for the road. No cracks on the sidewall, and to have at least (50%) of tread depth.

Step 3: Make sure you have no centre caps and wheel weights.

Before mounting the wheel onto the machine, make sure you have your centre caps off (if you have them), and the old wheel weights from the previous balancing off. This is to ensure that you get the most accurate results from the machine.

Step 4: Mount the wheel.

After you have done all the previous steps, you can now safely mount your wheel onto the machine. Once it is on, double check to make sure that the wheel is snug tight.

Step 5: Measure the wheel.

Once the wheel is on, the machine will want to know the size of the rim. You will have to measure the height of the rim, as well as the width.

Step 6: Select your vehicle.

Depending on the machine you're using, it may have a feature which allows you to choose what type of vehicle this wheel will be going on so it can put the proper amount of road force when it's being tested.

Step 7: Enter proper tire pressure accordingly to your vehicle specifications.

If you don't do this before closing down the hood, it will ask you if you have done it or not to be a reminder.

Step 8: Start.

Once you have measure your rims and have chosen the proper type of vehicle, you can simply presses start or close the hood.



Step 9: Install wheel weights.

Once the machine has finished testing the road force and balance the wheel, it will tell you how much weight it wants and what side of the wheel.

Step 10: Rebalance.

Once you have install the wheel weights, you want to rebalance the wheel to make sure you added the proper amount of the wheel weights, and at the proper spot of the rim it has asked.

Step 11: Finish up.

This means now your wheel is balanced.

Q16. Explain the classification of tyres based on season and application.

Answer:

1. **Summer Tyres:**

Summer tyres are designed to work best during the warmer summer months.

They are created with a specific tread pattern for optimal performance on both dry and wet roads when the air temperature is above +7°C.

2. **Winter tyres:**

look very similar to summer tyres but are specially developed to provide additional driving performance in winter conditions. It is a common misconception that winter tyres are only for driving in the snow.

Winter tyres are designed to work best in conditions below +7°C, so even in wet and icy conditions, you'll benefit from their superior grip and handling.

3. **All season tyres**

essentially combine elements of summer tyres and winter tyres.

To create a tyre that has benefits of both so that they can be used all-year round, giving drivers peace of mind whatever the weather throws at them.

While all season car tyres are not likely to match the performance of specialist summer or winter tyres during these respective seasons, they provide a good all-round mix of strengths.

Q17. Define Camber, Castor & Toe angles of wheel geometry.

Answer:

Camber:

This suspension angle shows how the tire angles away from 0 degrees vertical when viewed from either the front or rear of the vehicle. Expressed in degrees, negative camber means the top of the tire tilts toward the centre of the vehicle, while positive camber means the top of the tire tilts away from centre. A visual cue for a camber problem is excessive tire wear on the inner or outermost ribs.

Caster:

This angle shows the forward or backward slope of a line drawn through the upper and lower steering pivot points, when viewed directly from the side of the vehicle.

Also expressed in degrees, caster is measured by “comparing a line running through the steering system’s upper and lower pivot points to a line drawn perpendicular to the ground,”

Toe:

Identifies the direction tires are pointed relative to the centerline of the vehicle, when viewed from directly above. Toe can be expressed in either degrees or fractions of an inch.

Q18. Explain the components & working of an Electric Power Assisted Steering System with the help of a diagram.

Answer:

- A hybrid type of electronic power steering has been in place for some time now, but that included the use of an electric motor to drive a hydraulic pump.
- The new version of EPS is all electronic. The system works by incorporating information with the EPS control unit, EPS motor, reduction gear and torque sensor.

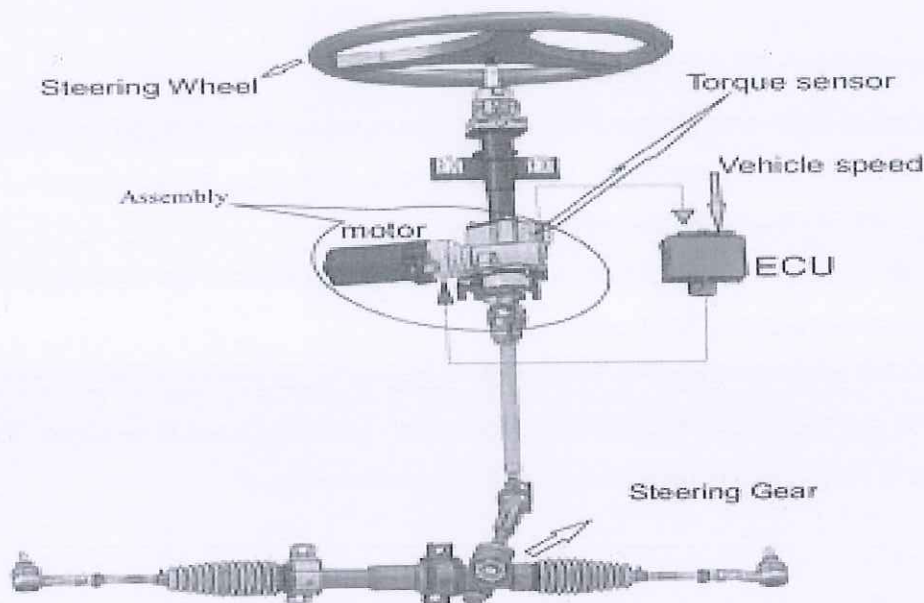

- An EPS system works by using a pinion gear assist that provides the power assist by rotating the pinion gear. The reduction gear is press fitted onto a set of splines on the pinion shaft and delivers the assist to the rack gear instead of pushing on the rack gear as in a hydraulic system.

COMPONENT OF ELECTRIC STEERING SYSTEM

- Steering Wheel
- Steering Column & Shaft
- Universal Joint
- Steering Gear Box
- Steering Pump



- Electric motor
- Linkage (Tie Road)
- Reduction Gear
- ECU (**Electronic Control Unit**)
- Torque sensor

Reduction Gear

Gear mechanism that increases the rotational torque generation by the motor and transmits it to the pinion gear.

Electric Motor

Outputs rotating torque according to the required power-assist calculation.

ECU

Calculate the amount of power-assist required according to driver's steering force and vehicle speed signal.

HOW ELECTRIC STEERING SYSTEM WORKS

- The steering gear itself is a manual rack with an electric motor mounted on the steering column or the rack. When the driver turns the wheel, a steering sensor detects the position and rate of rotation of the steering wheel.
- This information along with input from a torque sensor mounted in the steering shaft is sent to the power steering control module.
- The system also uses other inputs from vehicle speed sensors and the traction control system which are factored in to determine how much steering assist is required. The control module then tells the motor to rotate the required amount.



School of Automotive Skills
Session: 2020-21 (Summer Semester)
B. Voc. Program, 1st Semester,
End-Sem. Examination

CP Set A

Course Code: AUT1103

Course Name: Automotive Body Repair

Set A

Time: 2 Hours

Max. Marks: 50

Instruction:

1. Answer all questions from section A, each question carries one mark.
2. Answer all questions from section B, each question carries four marks.
3. Answer all questions from section C, each question carries six marks.

Section – A

10X01 = 10 Marks

- Q.1. Out of the following option which one is not a body panel?
a. Door
b. Wheel
c. Fender
d. Bumper
- Q.2. Which of the following is not a shearing process?
a. Punching
b. Drawing
c. Blanking
d. Parting
- Q.3. Velocity of plasma stream during plasma cutting operation is close to
a. 200m/s
b. 400m/s
c. 600m/s
d. 800m/s
- Q.4. Non consumable electrode is used in which of the following welding process?
a. MMAW
b. MIG
c. TIG
d. MAG
- Q.5. which one is not shielding gas type welding?
a. MMAW
b. TIG
c. MIG
d. MAG
- Q.6. Solder is an alloy of
a. Brass and Copper
b. Aluminium and Zinc
c. Tin and Lead
d. Aluminium and Brass
- Q.7. What is the color code of prohibition sign?
a. Red
b. Yellow
c. Black
d. Blue
- Q.8. Which of the car does not have D pillar?
a. Saloon
b. Wagon
c. Estate
d. MPV
- Q.9. Two door car that generally has either 2 seats or 4 seats in a 2+2 configuration is known as
a. Convertible
b. Cabriolet
c. Coupe
d. Wagon
- Q.10. front section of the car is also known as
a. Dog house
b. Cat house
c. Green house
d. None of the above

Section – B

04X04 = 16 Marks

- Q.1. Differentiate between soldering and brazing.
- Q.2. What are the roles and responsibilities of an auto body repairer?



- Q.3. What are the various types of car body section? Name three parts falls in each body section.
- Q.4. What is Plasma cutting? Explain components of plasma cutting.

Section – C

04X06 = 24 Marks

- Q.1. Write a short note on the following:
- a. 5S theory
 - b. Electrode coating
 - c. Notching
- Q.2. Define Dent and briefly explain various types of dents.
- Q.3. Explain the working TIG with a suitable diagram.
- Q.4. Explain Metal Inert Gas welding with the help of an diagram.



School of Automotive Skills
Session: 2020-21 (Summer Semester)
B. Voc. Program, 1st Semester,
End-Sem. Examination

Answer key

Set A

Course Code: AUT1103

Course Name: Automotive Body Repair

Time: 2 Hours

Max. Marks: 50

Answer key

Instruction:

1. Answer all questions from section A, each question carries one mark.
2. Answer all questions from section B, each question carries four marks.
3. Answer all questions from section C, each question carries six marks.

Section – A

10X01 = 10 Marks

- Q.1. Out of the following option which one is not a body panel?
a. Door
b. Wheel
c. Fender
d. Bumper
- Q.2. Which of the following is not a shearing process?
a. Punching
b. Drawing
c. Blanking
d. Parting
- Q.3. Velocity of plasma stream during plasma cutting operation is close to
a. 200m/s
b. 400m/s
c. 600m/s
d. 800m/s
- Q.4. Non consumable electrode is used in which of the following welding process?
a. MMAW
b. MIG
c. TIG
d. MAG
- Q.5. which one is not shielding gas type welding?
a. MMAW
b. TIG
c. MIG
d. MAG
- Q.6. Solder is an alloy of
a. Brass and Copper
b. Aluminium and Zinc
c. Tin and Lead
d. Aluminium and Brass
- Q.7. What is the color code of prohibition sign?
a. Red
b. Yellow
c. Black
d. Blue
- Q.8. Which of the car does not have D pillar?
a. Saloon
b. Wagon
c. Estate
d. MPV
- Q.9. Two door car that generally has either 2 seats or 4 seats in a 2+2 configuration is known as
a. Convertible
b. Cabriolet
c. Coupe
d. Wagon
- Q.10. front section of the car is also known as
a. Dog house
b. Cat house
c. Green house
d. None of the above

Section – B

04X04 = 16 Marks

- Q.1. Differentiate between soldering and brazing.



BHARTIYA SKILL DEVELOPMENT UNIVERSITY

Ans. **Soldering** is a process in which two or more metal are joined together by melting and putting a filler metal (solder) into the joint, the filler metal having a lower melting point than the parent metals.

- Brazing is when a filler metal or alloy is heated to its melting temperature above 450 °C.
- In this case only filler metal melts, there is no melting of work piece metal.
- But this process need preheating of base metal.

Q.2. What are the roles and responsibilities of an auto body repairer?

Ans. An auto body technician can repair most damage from everyday vehicle collisions and make vehicles look and drive like new.

- Damage may be minor, such as replacing a cracked windshield, or major, such as replacing an entire door panel.
- They can do all body work.

Q.3. What are the various types of car body section? Name three parts falls in each body section.

Ans. Car body section are divided into major three section:

- Front section- Front section includes everything between front bumper and fire wall. Also called nose section, front clip, “doghouse”
- Mid-section- Center section or Mid-section includes body parts that form passenger compartment. Also called a “greenhouse”
- Rear section- Rear section also called tail section, rear clip, “cathouse”

Q.4. What is Plasma cutting? Explain components of plasma cutting.

- Ans. Plasma arc cutting is a process resulting from ionizing a column of gas (argon, nitrogen, helium, air, hydrogen or their mixture) with extreme heat of an electric arc.
- The ionized gas along with the arc is forced through a very small nozzle orifice, resulting into a plasma stream of high velocity (up to 600 m/sec) and high temperature (up to 20000° k).
- When this high speed is reached, high temperature plasma stream and electric arc strike the workpiece, and ion in the plasma recombine into gas atoms and liberate a great amount of latent heat.
- This heat melts the workpiece, vaporizes part of the material and the balance is blasted away in the form of molten metal through the heat.

Section – C

04X06 = 24 Marks

Q.1. Write a short note on the following:

- a. 5S theory
- b. Electrode coating
- c. Notching

Ans: Electrode can be classified as:

- A= Acid Coating
- B= Basic Coating
- C= Cellulose Coating
- R= Rutile Coating

Q.2. Define Dent and briefly explain various types of dents.



BHARTIYA SKILL DEVELOPMENT UNIVERSITY

Ans. **Car Dings** – caused by smaller objects and are easy to repair as long as no damage to the vehicles paint has occurred.

- **Round Dents** – caused from hailstones or a similarly round object (football, baseball, basketball, etc.) hitting the car and causing a dimple on the door, bumper, roof or hood.
- **Crease Type Dents** – Crease dents usually bends and tears the car's metal. When an automobile acquires a crease type dent, it is possible to lose the metal memory making it hard to repair back to original shape.

Q.3. Explain the working TIG with a suitable diagram.

- Ans. Tungsten Inert Gas Welding (TIG Welding), also known as Gas Tungsten Arc Welding (GTAW).
- It is an Arc welding method that uses a non-consumable tungsten electrode to weld two or more work pieces.
- It is very much similar to Metal Inert Gas (MIG) Welding.
- Commonly used to weld thin sections of stainless steel and non-ferrous metals such as aluminium, magnesium, and copper alloys.

Q.4. Explain Metal Inert Gas welding with the help of an diagram.

- Ans. Metal inert gas welding takes its name from the use of inert gases such as argon, helium and mixture of the two gases.
- MIG welding is an arc welding process in which a continuous solid wire electrode is fed through a welding gun and into the weld pool, joining two base material together.
- The process is semi- automatic because the electrode and gas are automatically fed through a welding the gun at a user defined speed when the operator pulls down the trigger.



School of Automotive Skills
Session: 2020-21 (Summer Semester)
B. Voc. Program, 1st Semester,
End-Sem. Examination

Course Code: AUT1103

Time: 2 Hours

Course Name: Automotive Body Repair *Set B*

Max. Marks: 50

Instruction:

1. Answer all questions from section A, each question carries one mark.
2. Answer all questions from section B, each question carries four marks.
3. Answer all questions from section C, each question carries six marks.

Section – A

10X01 = 10 Marks

- Q.1. Number of body panels in a car is....
- a. 10
 - b. 11
 - c. 13
 - d. 12
- Q.2. Which of the following is a forming process?
- a. Punching
 - b. Stretching
 - c. Blanking
 - d. Parting
- Q.3. Which one is not a body type?
- a. Convertible
 - b. Cabriolet
 - c. Coupe
 - d. Monocoque
- Q.4. Middle section of the car is also known as
- a. Dog house
 - b. Cat house
 - c. Green house
 - d. None of the above
- Q.5. what is color code of warning sign?
- a. Blue
 - b. Green
 - c. Yellow
 - d. Red
- Q.6. Full form of ATV is...
- a. All transfer vehicle
 - b. All-terrain vehicle
 - c. Active transfer vehicle
 - d. Active terrain vehicle
- Q.7. In which of the following operation the sheet is sheared into two or more pieces.
- a. Slitting
 - b. Lancing
 - c. Parting
 - d. Forming
- Q.8. Non consumable electrode is used in which of the following welding process?
- a. MMAW
 - b. MIG
 - c. TIG
 - d. MAG
- Q.9. which one is not related to Soldering
- a. Solder
 - b. Flux
 - c. Shielding gas
 - d. None of the above
- Q.10. Which of the following is not used as filler material in brazing?
- a. Copper
 - b. Magnesium
 - c. Lead
 - d. Silver



Section – B

04X04 = 16 Marks

- Q.1. Explain backbone and Monocoque chassis and enlist the difference between them.
- Q.2. What are the advantages of MIG welding?
- Q.3. Explain soldering and brazing.
- Q.4. What are the various types of car body section? Name three parts falls in each body section.

Section – C

04X06 = 24 Marks

- Q.1. Write a short note on the following:
 - a. Blanking
 - b. Perforating
 - c. Parting
- Q.2. Define TIG and briefly explain the working of TIG.
- Q.3. Explain the working principle of plasma cutter with a suitable diagram.
- Q.4. Briefly explain the following processes with respect to sheet metal working:
 - a. Shearing process
 - b. Forming process
 - c. Finishing process



School of Automotive Skills
Session: 2020-21 (Summer Semester)
B. Voc. Program, 1st Semester,
End-Sem. Examination

Answer key
set B

Course Code: AUT1103

Course Name: Automotive Body Repair

Time: 2 Hours

Max. Marks: 50

Answer key - set B

Instruction:

1. Answer all questions from section A, each question carries one mark.
2. Answer all questions from section B, each question carries four marks.
3. Answer all questions from section C, each question carries six marks.

Section – A

10X01 = 10 Marks

- Q.1. Number of body panels in a car is....
a. 10
b. 11
c. 13
d. 12
- Q.2. Which of the following is a forming process?
a. Punching
b. Stretching
c. Blanking
d. Parting
- Q.3. Which one is not a body type?
a. Convertible
b. Cabriolet
c. Coupe
d. Monocoque
- Q.4. Middle section of the car is also known as
a. Dog house
b. Cat house
c. Green house
d. None of the above
- Q.5. what is color code of warning sign?
a. Blue
b. Green
c. Yellow
d. Red
- Q.6. Full form of ATV is...
a. All transfer vehicle
b. All-terrain vehicle
c. Active transfer vehicle
d. Active terrain vehicle
- Q.7. In which of the following operation the sheet is sheared into two or more pieces.
a. Slitting
b. Lancing
c. Parting
d. Forming
- Q.8. Non consumable electrode is used in which of the following welding process?
a. MMAW
b. MIG
c. TIG
d. MAG
- Q.9. which one is not related to Soldering
a. Solder
b. Flux
c. Shielding gas
d. None of the above
- Q.10. Which of the following is not used as filler material in brazing?
a. Copper
b. Magnesium
c. Lead
d. Silver



Section – B

04X04 = 16 Marks

- Q.1. Explain backbone and Monocoque chassis and enlist the difference between them.
- Monocoque Chassis is a one-piece structure that prescribes the overall shape of a vehicle.
 - This type of automotive chassis is manufactured by welding floor pan and other pieces together

- Q.2. What are the advantages of MIG welding?
- Ans. Higher welding speeds
 - Greater deposition rates
 - Less post welding cleaning (e.g. no slag to chip off weld)
 - Better weld pool visibility

The process is easily automated

- Q.3. Explain soldering and brazing.
- Ans. Soldering is normally done by melting the solder with a soldering iron and applying it to the two metals that are going to be joined together.
 - The filler metal used in the process is called solder.
 - Soldering is done temperature below 450°C

- Q.4. What are the various types of car body section? Name three parts falls in each body section.

Ans. Car body section are divided into major three section:

- Front section- Front section includes everything between front bumper and fire wall. Also called nose section, front clip, “doghouse”
- Mid section- Center section or Mid section includes body parts that form passenger compartment. Also called a “greenhouse”
- Rear section- Rear section also called tail section, rear clip, “cathouse”

Section – C

04X06 = 24 Marks

- Q.1. Write a short note on the following:
- a. Blanking
 - b. Perforating
 - c. Parting
- Ans. Shearing process using a die and punch where the exterior portion of the shearing operation is to be discarded.

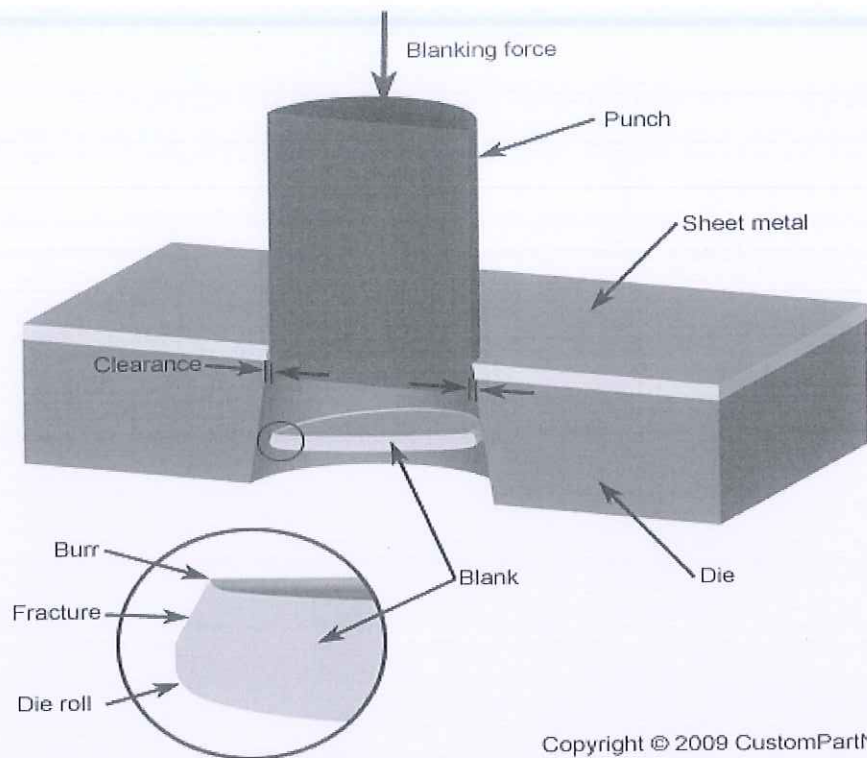

Copyright © 2009 CustomPartNet

Q.2. Define TIG and briefly explain the working of TIG.

- Ans. Tungsten Inert Gas Welding (TIG Welding), also known as Gas Tungsten Arc Welding (GTAW).
- It is an Arc welding method that uses a non-consumable tungsten electrode to weld two or more work pieces.
- It is very much similar to Metal Inert Gas (MIG) Welding.
- Commonly used to weld thin sections of stainless steel and non-ferrous metals such as aluminium, magnesium, and copper alloys.

Q.3. Explain the working principle of plasma cutter with a suitable diagram.

- Ans. Plasma arc cutting is a process resulting from ionizing a column of gas (argon, nitrogen, helium, air, hydrogen or their mixture) with extreme heat of an electric arc.
- The ionized gas along with the arc is forced through a very small nozzle orifice, resulting into a plasma stream of high velocity (up to 600 m/sec) and high temperature (up to 20000° k).
- When this high speed is reached, high temperature plasma stream and electric arc strike the workpiece, and ion in the plasma recombine into gas atoms and liberate a great amount of latent heat.
- This heat melts the workpiece, vaporizes part of the material and the balance is blasted away in the form of molten metal through the heat.

Q.4. Briefly explain the following processes with respect to sheet metal working:

- a. Shearing process
- b. Forming process
- c. Finishing process

Ans. Sheet metal processes can be broken down into two major classifications and one minor classification.

1. **Shearing processes** -- processes which apply shearing forces to cut, fracture, or separate the material.



BHARTIYA SKILL DEVELOPMENT UNIVERSITY

2. **Forming processes** -- processes which cause the metal to undergo desired shape changes without failure, excessive thinning, or cracking. This includes bending and stretching.
3. **Finishing processes** -- processes which are used to improve the final surface characteristics.



School of Automotive Skills

Session: 2020-21 (Summer Semester)

B. Voc. Program, 1st Semester,

End-Sem. Examination

Set A

Course Code: AUT1104

Time: 2 Hours

Course Name: Automotive Spray Painting

Max. Marks: 50

Instruction:

1. Answer all questions from section A, each question carries one mark.
2. Answer all questions from section B, each question carries four mark.
3. Answer all questions from section C, each question carries six mark.

Section – A

10X01 = 10 Marks

Q.1 What is the function of dry guide coat?

- a. To check surface level
- b. For better adhesion
- c. For easy sanding
- d. All of the above

Q.2 What is the mixing ratio of body filler and hardener?

- a. 100gms: 20gms
- b. 100gms: 2gms
- c. 100gms: 2mg
- d. None of the above

Q.3 What is the role of pigment in paint?

- a. It helps in drying
- b. It gives hardness to paint
- c. It gives viscosity to paint
- d. It gives the colour

Q.4 Which chemical is found in hardener?

- a. Isocyanate
- b. Butane
- c. Xylene
- d. None of the above

Q.5 What is the role of binder?

- a. It provide color
- b. It provide specific properties
- c. It provide gloss, hardness, durability
- d. It reduce the viscosity of paint

Q.6 What do you mean by degreasing?

- a. Process of spot repair
- b. Process of cleaning surface
- c. Process of color mixing
- d. Both (b) & (c)

Q.7 What is the another name of double action sander?

- a. Flat-bed sander
- b. Belt sander
- c. Single action sander
- d. Random orbital sander

Q.8 Which type of paint is environment friendly and safe for paint technician health?

- a. NC paint
- b. 2K paint
- c. Waterborne
- d. Synthetic paint



BHARTIYA SKILL DEVELOPMENT UNIVERSITY

Q.9 What should be angle of gun respected to the panel while spraying paint?

- a. 15 degree
- b. 60 degree
- c. 45 degree
- d. 90 degree

Q.10 What are the primary colors?

- a. Red, yellow, blue
- b. Green, orange, red
- c. Blue, violet, green
- d. None of the above

Section – B

04X04 = 16 Marks

Q.11 Write short notes on:

- a. 2K products
- b. Binder

Q.12 Write the do's and don'ts of paint-booth.

Q.13 What is a body filler? Also write about different types of body fillers.

Q.14 Write about all kind of safety equipment's used in a paint shop.

Section – C

04X06 = 24 Marks

Q.15 What is a primer surfacer? Explain different properties of a primer surfacer.

Q.16 What is the function of paint booth filters? Explain how many types of filters are use in a paint booth?

Q.17 Explain different types of sanding discs.

Q.18 What a is spray gun? Explain different types of spray guns.



School of Automotive Skills

Session: 2020-21 (Summer Semester)

B. Voc. Program, 1st Semester,

End-Sem. Examination

SETA

Course Code: AUT1104

Course Name: Automotive Spray Painting

Time: 2 Hours

Max. Marks: 50

*Answer set A
key*

Instruction:

1. Answer all questions from section A, each question carries one mark.
2. Answer all questions from section B, each question carries four mark.
3. Answer all questions from section C, each question carries six mark.

Section – A

10X01 = 10 Marks

Q.1 What is the function of dry guide coat?

- a. **To check surface level**
- b. For better adhesion
- c. For easy sanding
- d. All of the above

Q.2 What is the mixing ratio of body filler and hardener?

- a. 100gms: 20gms
- b. **100gms: 2gms**
- c. 100gms: 2mg
- d. None of the above

Q.3 What is the role of pigment in paint?

- a. It helps in drying
- b. It gives hardness to paint
- c. It gives viscosity to paint
- d. **It gives the colour**

Q.4 Which chemical is found in hardener?

- a. **Isocynate**
- b. Butane
- c. Xylene
- d. None of the above

Q.5 What is the role of binder?

- a. It provide color
- b. It provide specific properties
- c. **It provide gloss, hardness, durability**
- d. It reduce the viscosity of paint

Q.6 What do you mean by degreasing?

- a. Process of spot repair
- b. **Process of cleaning surface**
- c. Process of color mixing
- d. Both (b) & (c)

Q.7 What is the another name of double action sander?

- a. Flat-bed sander
- b. Belt sander
- c. Single action sander
- d. **Random orbital sander**

Q.8 Which type of paint is environment friendly and safe for paint technician health?

- a. NC paint
- b. 2K paint
- c. **Waterborne**
- d. Synthetic paint



Q.9 What should be angle of gun respected to the panel while spraying paint?

- a. 15 degree
- b. 60 degree
- c. 45 degree
- d. **90 degree**

Q.10 What are the primary colors?

- a. **Red, yellow, blue**
- b. Green, orange, red
- c. Blue, violet, green
- d. None of the above

Section – B

04X04 = 16 Marks

Q.11 Write short note on:

- a. 2K products
- b. Binder

Ans: (a) 2K primer or products come in 2 pack. Primer and hardener come different different packs.

Urethane Primer Surfacer

- Urethane Primer is the next coating you should use after epoxy or self-etching primer and filler.
- This is used where you will really want the bodywork to become nice and flat.
- We suggest finishing the surface with 180-220 grit sandpaper before applying urethane primer.
- Designed for overall jobs
- Excellent colour holdout for all top coats
- Sand able - Light Filling
- Apply over- bare metal, body fillers, existing finishes

Ans: (b)

Binder: -

1. It provides paint its gloss.
2. It also provides hardness, durability and adhesion.
3. It also wets the pigment from a powder to a liquid.

Q.12 Write do's and don'ts of paint-booth.

Ans:

Do's:

1. While switch on the paint booth, please ensure that voltage is above 380volts.
2. Keep the paint booth and its surroundings clean.
3. Sanding is not advisable in surrounding of paint booth.
4. Open the main door only for vehicle entry.
5. For all other movements use only service door.
6. Please insure the vehicle and technician dress must be dust free.
7. Switch off the main supply after completion of work.

Don'ts:

1. Don't store paints and accessories inside paint booth.
2. Don't use any cotton waste inside paint booth.
3. Don't spray the paint/test the spray gun on floor filter.
4. Don't throw the waste paint material on the floor filter.
5. Don't use compressed air for cleaning the paint booth walls and floor.
6. Don't allow sparks inside the paint booth.
7. Don't open the main door during painting.

Q.13 What is body filler? Also write different types of body filler.

Ans: Body Filler:

It is a mixture that contains fiberglass resin (polyester) and talc.

1. The resin provides adhesion.
2. The talc makes the material flow smoothly.
3. The main solvent in the filler is styrene.
4. It uses a catalyst to Harden which is MEK (methyl ethyl ketone)

There are three types of putty/body fillers: -

1. Standard
2. Mid-range
3. Premium

Q.14 Brief about all kind of safety equipment used in paint shop.

Ans:

Safety Equipment:

1. Hand gloves.
2. Safety shoes
3. Mask and respirator
4. Safety glasses
5. Protective Clothing.
6. Ear plugs.

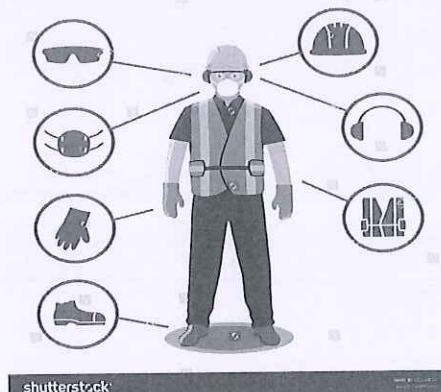



Q.15 What is primer surfacer? Explain different properties of primer surfacer.

Ans:

Primer Surfacer is ideal for improving adhesion of the final topcoat and enhancing paint's color. When brushed or sprayed to metal or fiberglass surfaces, this high build, rust resistant, sandable formula will hide sanding scratches and quickly fills uneven surfaces.

2K Primer Surfacer is a very fast curing, easy sanding **primer** or wet-on-wet sealer, that provides good sand scratch filling, no settling in the can, excellent adhesion and topcoat holdout.

Generally, one to two **coats of primer** will suffice for painting interior walls, but **how many** you'll **need** depends on the wall material, the paint color, and the type of **primer** used.

Urethane Primer Surfacer

- Urethane Primer is the next coating you should use after epoxy or self-etching primer and filler.
- This is used where you will really want the bodywork to become nice and flat.
- We suggest finishing the surface with 180-220 grit sandpaper before applying urethane primer.

Q.16 What is the function of paint booth filters? Explain how many types of filters are use in a paint booth?

Ans:

Air makeup filters come in multiple varieties such as pad, panel, cleanable aluminum and pocket and bag filters. ... This is the importance of intake filters; they provide clean, filtered air to the booth so your coating operation is free of foreign particles that can contaminate your paint job.

Pre-Filters

Pre-filters are made from ultra-fibre glass. Hence it is easy to handle. The offered paint booth filter is extensively used in industrial and commercial applications. Pre-filters are placed outside the booth towards the right or left side. They can be used to filter incoming air or outgoing or exhausted air.

Ceiling Filters

As the name implies, ceiling filters are placed on the roof of the booth. A ceiling filter lasts for maximum 8 to 9 months. It is used to collect dust from the roof side. These filters can be customised. The sizes we offer are:

AVAILABLE SIZES:

- 1.0 Meter x 20 Meter (Rolls)
- 1.5 Meter x 20 Meter(Rolls)
- 2.0 Meter x 20 Meter(Rolls)



Paint Stop Filters/Floor Filters

- Paint stop filters are to be placed inside the booth, on the floor and left, right and back side of the booth. The duration is maximum 200 hours. Such filters are not suitable for oil based paint. The available sizes are:

AVAILABLE SIZES:

0.8 Meter x 20 Meter (Rolls)

1.0 Meter x 20 Meter (Rolls)

1.5 Meter x 20 Meter (Rolls)

2.0 Meter x 20 Meter (Rolls)

Q.17 Explain different types of sanding disc.

Ans:

: P- 80-Grit

In contrast to sandpapers in the 32 to 40-grit range, 80-grit sandpaper is not terribly rough on the surface of vehicle panels. As such, 80-grit can be applied to the hood, roof or door panels of a car or van without leaving rough streaks. However, light streaking will still be present if you apply heavy force. Therefore, the use of 80-grit sandpaper on a vehicle will usually need to be followed by a smooth-out sanding with a higher-grit sandpaper. Ultimately, 80-grit is best used on vehicles that need considerable sanding in select areas, but without the roughness of lower-grit options.

320-Grit

At this point along the wet sandpaper grit chart, the options are ideal for smooth buffering as well as the removal of thick paint. With a 320-grit piece of sandpaper, paint should come off the vehicle with evenly applied strokes of a disc. By the time you work a 320-grit through the paint, the shiny, silvery lustre of the metal should come glaring to the surface. Thanks to the strength of 320-grit sandpaper, it's a good option for cars or vans that have been treated with enamel or other hard coats. A perfect example of how 320-grit sandpaper can work is when you want to turn a blue van red. Before you apply the new paint job, you'll want to sand away the older blue coats. With 320-grit, the blue should come off smoothly and easily. Once all of the panels have been stripped, the surfaces should be smooth enough for a primer coat of the new paint. Alternately, 320-grit could make it really easy to change out the paint on a single panel, such as a scratched door. As such, when people ask what grit sandpaper to use when painting a car, 320-grit is a good choice for large automobiles with thick coats.

400-Grit

When it comes to finishing, the most popular option is 400-grit sandpaper. Before the new coat of paint is applied, 400-grit paper makes prepping smooth and easy. If there are any



rough areas spotted along the surface or edges of a given panel, 400-grit could be used to smooth the metal out in a way that lower grits might be incapable of. The best thing about 400-grit sandpaper is that, despite its strength, it's fine enough to handle challenges along an auto-body surface without roughing up the metal. When the question arises about what grit sandpaper is appropriate for a wet sanding primer, 400-grit is sometimes stressed as better for wet sanding than for dry sanding. The reasoning here is that, when dry, 400-grit tends to leave sand on the subject, which can be troublesome as far as finishing work is concerned. Therefore, while 400-grit is one of the most popular grits of sandpaper, it's often used exclusively for wet sanding. As such, 400-grit is one of the most widespread options on the wet sandpaper grit chart.

600-Grit

When it comes to correcting errors in soft layers of paint, 600-grit sandpaper makes the task relatively easy. Likewise, if paint runs out before a panel has been fully covered, the edges of the paint can be sanded smooth with a wet 600. Basically, 600-grit sandpaper is a perfect option when you need to salvage the panels after a paint job has hit a snag. When you consider all the time and money that can slip down the drain when a vehicle-painting project doesn't go as planned, 600-grit sandpaper is a lifesaver because it reduces complications. For example, you might be painting a car with a unique color that has to be specially ordered, but end up with a bad passenger door or roof due to the paint running out when you're 93-percent finished. In an earlier set of circumstances, you might have needed to do the paintjob over again, yet still be at risk of running out along another part of the vehicle. With 600-grit sandpaper, it needn't be as costly or time-consuming, because the raw edges of an unfinished paint job can be sanded back for a recoat and will therefore be ready by the time a new supply of the same paint arrives.

Q.18 What a is spray gun? Explain different types of spray guns.

Ans:

A spray gun is a piece of equipment which you use to spray paint under pressure onto a surface.

The spray gun is the most popular type of spray application equipment use

- An spray gun is a tool which uses compressed air to atomise paint and to apply it to a surface.
- Air and material enter the gun through separate passages and are mixed at the air cap in a controlled pattern.

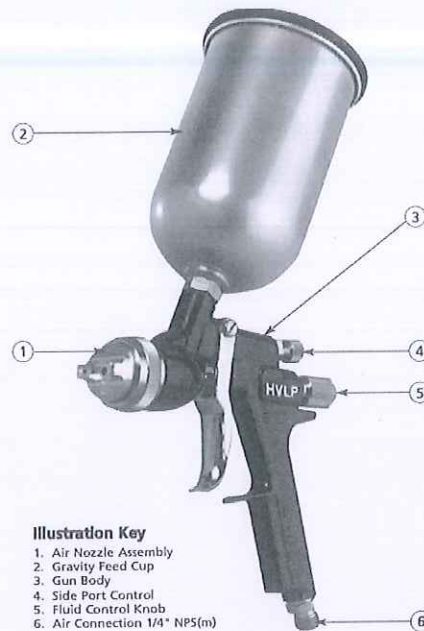

There are primarily four types of gun: -

1. Cup spray guns
2. Air spray guns
3. Airless spray guns
4. HVLP spray guns

More recently with the advent of environmental pressure's

5. H.V.L.P. (High Volume, Low Pressure) guns were developed.
6. These guns reduce the amount paint bounce back, and overspray
7. by reducing the amount of air from the air cap down to approx.
8. 10 psi.
9. They have also been found to lower the paint consumption by
10. up to 25%

Proper technique for spray gun stroke

11. The stroke should be made with free arm
12. motion, keeping the gun at right angles to
13. the work surface.
14. Triggering should begin just before the edge
15. of the panel to be sprayed.
16. The trigger should be held fully depressed and the gun moved in
17. one continuous motion until the other edge of the panel is reached.
18. The trigger is then released shutting off the fluid flow, but motion
19. still continues for few more inches.
20. The stroke is then reversed for the return
21. spray pass.
22. Each spray pass should overlap the



BHARTIYA SKILL DEVELOPMENT UNIVERSITY

23. preceding one by approx. 50 %.

24. Move the gun at a constant speed while the trigger is pulled, since

25. material flows at a constant rate a 50% overlap should give you

26. uniform coverage.



School of Automotive Skills
Session: 2020-21 (Summer Semester)
B. Voc. Program, 1st Semester,
End-Sem Examination

SEB

Course Code: AUT1104

Time: 2 Hour

Course Name: Automotive Spray Painting

Max. Marks: 50

Instruction:

1. Answer all questions from section – A, each question carries One mark.
2. Answer all questions from section – B, each question carries Four marks.
3. Answer all questions from section – C, each question carries Six marks.

Section – A

10X01 = 10 Marks

Q.1 Which internal body organ is affected most from paint material containing organic solvents & 2K hardener?

- | | |
|----------|------------|
| a. Liver | c. Heart |
| b. Lungs | d. Stomach |

Q.2 What is the changing frequency of Floor Filter of Spray booth ?

- | | |
|-------------------|-----------------------|
| a. After 100 hrs. | c. After 200-250 hrs. |
| b. After 200 hrs. | d. None. |

Q.3 What is the recommended intensity of light inside the paint booth?

- | | |
|----------------|------------------|
| a. 100-200 lux | c. 1000-1500 lux |
| b. 500-800 lux | d. 1500-2000 lux |

Q.4 Which type of paint is environment friendly and also safe for health of paint technician?

- | | |
|---------------------|--------------------|
| a. Waterborne paint | c. 2K paint |
| b. NC Paint | d. Synthetic paint |

Q.5 What is the mixing ratio of body filler and hardener?

- | | |
|-----------------|----------------------|
| a. 100gm: 20gm | c. 100gms: 2mg |
| b. 100gms: 2gms | d. None of the above |

Q.6 Which type of sanding process is recommended by OEM for refinish painting?

- | | |
|----------------|----------------------|
| a. Dry sanding | c. Both (a) & (b) |
| b. Wet sanding | d. None of the above |

Q.7 Which nozzle size spray-gun is required for clear coat application?

- | | |
|-----------|-----------|
| a. 1.2 mm | c. 1.6 mm |
| b. 1.4 mm | d. 1.8 mm |



Q.8 Which type of chemical is found in hardener?

- a. Isocyanate
- b. Butane
- c. Xylene
- d. None of the above

Q.9 What should be the angle of spray-gun with respect to the panel while spraying paint?

- a. 15 degree
- b. 60 degree
- c. 45 degree
- d. 90 degree

Q.10 Which colors are known as primary colors?

- a. Red, yellow, blue
- b. Green, orange, red
- c. Blue, violet, green
- d. None of the above

Section – B

04X04 = 16 Marks

Q.1 Write any four differences between a primer and a primer-surfacer?

Q.2 Write a short note on:

- a. DFT
- b. Dual action sander

Q.3 Write the do's and don'ts for paint booth.

Q.4 What is a body filler? What are the different types of body filler?

Section – C

04X06 = 24 Marks

Q.1 Explain different types of hazards associated with an automotive paint shop.

Q.2 What is process of dry sanding? Explain different of types of dry sanding.

Q.3 Explain different types of sanding disc based on application.

Q.4 What is a spray gun? Explain different types of spray guns.



School of Automotive Skills
Session: 2020-21 (Summer Semester)
B. Voc. Program, 1st Semester,
End-Sem Examination

Set B

Answer key - set B

Course Code: AUT1104

Time: 2 Hour

Course Name: Automotive Spray Painting

Max. Marks: 50

Instruction:

1. Answer all questions from section – A, each question carries One mark.
2. Answer all questions from section – B, each question carries Four marks.
3. Answer all questions from section – C, each question carries Six marks.

Section – A

10X01 = 10 Marks

Q.1 Which internal body organ is affected most from paint material containing organic solvents & 2K hardener?

- | | |
|-----------------|------------|
| a. Liver | c. Heart |
| b. Lungs | d. Stomach |

Q.2 What is the changing frequency of Floor Filter of Spray booth ?

- | | |
|-------------------|------------------------------|
| a. After 100 hrs. | c. After 200-250 hrs. |
| b. After 200 hrs. | d. None. |

Q.3 What is the recommended intensity of light inside the paint booth?

- | | |
|----------------|-------------------------|
| a. 100-200 lux | c. 1000-1500 lux |
| b. 500-800 lux | d. 1500-2000 lux |

Q.4 Which type of paint is environment friendly and also safe for health of paint technician?

- | | |
|----------------------------|--------------------|
| a. Waterborne paint | c. 2K paint |
| b. NC Paint | d. Synthetic paint |

Q.5 What is the mixing ratio of body filler and hardener?

- | | |
|------------------------|----------------------|
| a. 100gm: 20gm | c. 100gms: 2mg |
| b. 100gms: 2gms | d. None of the above |

Q.6 Which type of sanding process is recommended by OEM for refinish painting?

- | | |
|-----------------------|----------------------|
| a. Dry sanding | c. Both (a) & (b) |
| b. Wet sanding | d. None of the above |

Q.7 Which nozzle size spray-gun is required for clear coat application?

- | | |
|------------------|-----------|
| a. 1.2 mm | c. 1.6 mm |
| b. 1.4 mm | d. 1.8 mm |



Q.8 Which type of chemical is found in hardener?

- a. Isocyanate
- b. Butane
- c. Xylene
- d. None of the above

Q.9 What should be the angle of spray-gun with respect to the panel while spraying paint?

- a. 15 degree
- b. 60 degree
- c. 45 degree
- d. 90 degree

Q.10 Which colors are known as primary colors?

- a. Red, yellow, blue
- b. Green, orange, red
- c. Blue, violet, green
- d. None of the above

Section – B

04X04 = 16 Marks

Q.1 Write any four differences between a primer and a primer-surfacer?

Q.2 Write a short note on:

- a. DFT
- b. Dual action sander

Ans: DFT

- It is a coating thickness gauge used to measure dry film thickness.
- It is most critical measurements because of its impact on the coating process, quality and cost.

Or

- A coating thickness gauge (also referred to as a paint meter) is used to measure dry film thickness. Dry film thickness measurements can be used to evaluate a coating's expected life, the product's appearance and performance, and ensure compliance with a host of International Standards.

Q.3 Write the do's and don'ts for paint booth.

Ans:

Do's:

1. While switch on the paint booth, please ensure that voltage is above 380volts.
2. Keep the paint booth and its surroundings clean.
3. Sanding is not advisable in surrounding of paint booth.
4. Open the main door only for vehicle entry.
5. For all other movements use only service door.
6. Please insure the vehicle and technician dress must be dust free.
7. Switch off the main supply after completion of work.

Don'ts:



1. Don't store paints and accessories inside paint booth.
2. Don't use any cotton waste inside paint booth.
3. Don't spray the paint/test the spray gun on floor filter.
4. Don't throw the waste paint material on the floor filter.
5. Don't use compressed air for cleaning the paint booth walls and floor.
6. Don't allow sparks inside the paint booth.
7. Don't open the main door during painting.

Q.4 What is a body filler? What are the different types of body filler?

Ans: Body Filler:

It is a mixture that contains fiberglass resin (polyester) and talc.

1. The resin provides adhesion.
2. The talc makes the material flow smoothly.
3. The main solvent in the filler is styrene.
4. It uses a catalyst to Harden which is MEK (methyl ethyl ketone)

There are three types of putty/body fillers: -

1. Standard
2. Mid-range
3. Premium

Section – C

04X06 = 24 Marks

Q.1 Explain different types of hazards associated with an automotive paint shop.

Ans: Interior Painting Safety Hazards:

- Inadequate ventilation is the first and foremost hazard when painting indoors.
- Take care when placing appropriate warning signs for people place them at a level and in a position where the majority of people can see them easily.

Fire and explosion hazards:

- One of the major safety concerns associated with spray application is the combustible, flammable vapours and mists.
- It is important to ensure that all potential sources of ignition have been removed prior to spraying flammable and combustible products.

Health effects:

- Overexposure to a substance like primer or paint when spraying them means that too much has been breathed in, swallowed or absorbed.
- The possible health effects of overexposure to these products can vary depending on the chemicals they contain.

The main health effects from exposure to these solvents can include:

1. Eye and skin irritation



2. Respiratory tract irritation;
3. Dermatitis/Skin diseases
4. Drowsiness
5. Vomiting.

Potential sources of ignition include:

1. Open flames (work space heating units)
2. Cutting and welding torches
3. Gas fired heaters
4. Electrical outlets and lighting
5. Static electricity
6. Smoking

Q.2 What is process of dry sanding? Explain different of types of dry sanding.

Q.3 Explain different types of sanding disc based on application.

Ans:

: P- 80-Grit

In contrast to sandpapers in the 32 to 40-grit range, 80-grit sandpaper is not terribly rough on the surface of vehicle panels. As such, 80-grit can be applied to the hood, roof or door panels of a car or van without leaving rough streaks. However, light streaking will still be present if you apply heavy force. Therefore, the use of 80-grit sandpaper on a vehicle will usually need to be followed by a smooth-out sanding with a higher-grit sandpaper. Ultimately, 80-grit is best used on vehicles that need considerable sanding in select areas, but without the roughness of lower-grit options.

320-Grit

At this point along the wet sandpaper grit chart, the options are ideal for smooth buffering as well as the removal of thick paint. With a 320-grit piece of sandpaper, paint should come off the vehicle with evenly applied strokes of a disc. By the time you work a 320-grit through the paint, the shiny, silvery lustre of the metal should come glaring to the surface. Thanks to the strength of 320-grit sandpaper, it's a good option for cars or vans that have been treated with enamel or other hard coats. A perfect example of how 320-grit sandpaper can work is when you want to turn a blue van red. Before you apply the new paint job, you'll want to sand away the older blue coats. With 320-grit, the blue should come off smoothly and easily. Once all of the panels have been stripped, the surfaces should be smooth enough for a primer coat of the new paint. Alternately, 320-grit could make it really easy to change out the paint on a single panel, such as a scratched door. As such, when people ask what grit sandpaper to use when painting a car, 320-grit is a good choice for large automobiles with thick coats.

400-Grit



When it comes to finishing, the most popular option is 400-grit sandpaper. Before the new coat of paint is applied, 400-grit paper makes prepping smooth and easy. If there are any rough areas spotted along the surface or edges of a given panel, 400-grit could be used to smooth the metal out in a way that lower grits might be incapable of. The best thing about 400-grit sandpaper is that, despite its strength, it's fine enough to handle challenges along an auto-body surface without roughing up the metal. When the question arises about what grit sandpaper is appropriate for a wet sanding primer, 400-grit is sometimes stressed as better for wet sanding than for dry sanding. The reasoning here is that, when dry, 400-grit tends to leave sand on the subject, which can be troublesome as far as finishing work is concerned. Therefore, while 400-grit is one of the most popular grits of sandpaper, it's often used exclusively for wet sanding. As such, 400-grit is one of the most widespread options on the wet sandpaper grit chart.

600-Grit

When it comes to correcting errors in soft layers of paint, 600-grit sandpaper makes the task relatively easy. Likewise, if paint runs out before a panel has been fully covered, the edges of the paint can be sanded smooth with a wet 600. Basically, 600-grit sandpaper is a perfect option when you need to salvage the panels after a paint job has hit a snag. When you consider all the time and money that can slip down the drain when a vehicle-painting project doesn't go as planned, 600-grit sandpaper is a lifesaver because it reduces complications. For example, you might be painting a car with a unique color that has to be specially ordered, but end up with a bad passenger door or roof due to the paint running out when you're 93-percent finished. In an earlier set of circumstances, you might have needed to do the paintjob over again, yet still be at risk of running out along another part of the vehicle. With 600-grit sandpaper, it needn't be as costly or time-consuming, because the raw edges of an unfinished paint job can be sanded back for a recoat and will therefore be ready by the time a new supply of the same paint arrives.

Q.4 What is a spray gun? Explain different types of spray guns.

Ans:

A spray gun is a piece of equipment which you use to spray paint under pressure onto a surface.

The spray gun is the most popular type of spray application equipment use

- An spray gun is a tool which uses compressed air to atomise paint and to apply it to a surface.
- Air and material enter the gun through separate passages and are mixed at the air cap in a controlled pattern.

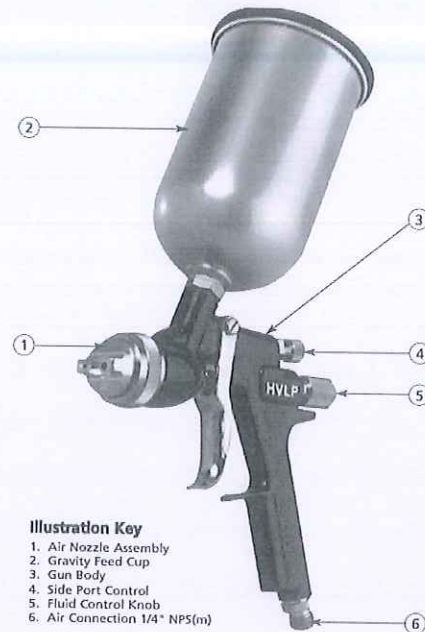

There are primarily four types of gun: -

1. Cup spray guns
2. Air spray guns
3. Airless spray guns
4. HVLP spray guns

More recently with the advent of environmental pressure's

5. H.V.L.P. (High Volume, Low Pressure) guns were developed.
6. These guns reduce the amount paint bounce back, and overspray
7. by reducing the amount of air from the air cap down to approx.
8. 10 psi.
9. They have also been found to lower the paint consumption by
10. up to 25%

Proper technique for spray gun stroke

11. The stroke should be made with free arm
12. motion, keeping the gun at right angles to
13. the work surface.
14. Triggering should begin just before the edge
15. of the panel to be sprayed.
16. The trigger should be held fully depressed and the gun moved in
17. one continuous motion until the other edge of the panel is reached.
18. The trigger is then released shutting off the fluid flow, but motion
19. still continues for few more inches.
20. The stroke is then reversed for the return
21. spray pass.



22. Each spray pass should overlap the

23. preceding one by approx. 50 %.

24. Move the gun at a constant speed while the trigger is pulled, since

25. material flows at a constant rate a 50% overlap should give you

26. uniform coverage.



School of Automotive Skills
1st Semester, End-Sem. Examination
B. Voc. Program, Summer Semester (2020-21)

8213

Course Code: AUT1105

Set-B

Time: 2 Hours

Course Name: Automotive Electrical Fundamentals and Comfort System

Max. Marks: 50

Instruction:

1. Answer all questions from section – A, each question carries one mark.
2. Answer all questions from section – B, each question carries four marks.
3. Answer all questions from section – C, each question carries six marks.

Section – A

10X01 = 10 Marks

1. The charging system:
 - a. Provides all electrical energy to operate the electrical system while the engine is running.
 - b. Restores the energy to the battery after starting the engine.
 - c. Uses the principle of magnetic induction to generate electrical power.
 - d. All of the above.
2. Why we use metallic shield for power cables in an automotive electrical?
 - a. To make it attractive.
 - b. To increase the electrical conductivity.
 - c. To protect the wire from the external forces.
 - d. All of the above.
3. Calculate the total resistance between the points A and B.

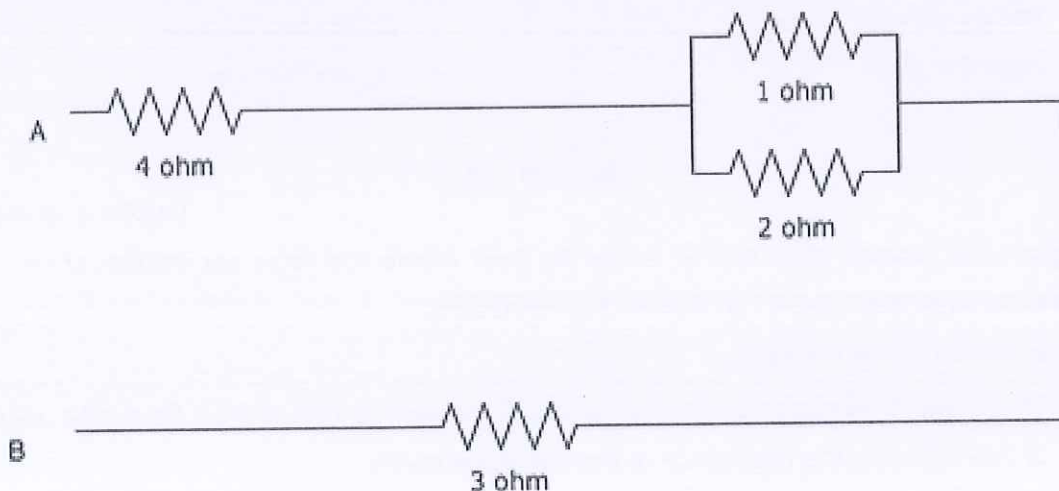

13. Define the following:

- | | |
|--------------------------------|------------------|
| a. Coefficient of performance. | c. Heat Pump. |
| b. Heat Engine. | d. Refrigerator. |

14. Draw a schematic chart of a simple VCERS cycle.

Section – C

04X06 = 24 Marks

15. Define AC Compressor, Condenser & Evaporator in detail.

16. Explain the following refrigerants and their properties:

- | | |
|----------|----------------------|
| a. HFC. | d. CO ₂ . |
| b. FC. | e. NH ₃ . |
| c. HCFC. | f. HC. |

17. Write down the standard operating procedure of AC Gas Recycling through Bosch Robinair ACS 261.

18. Differentiate between series and parallel connections.

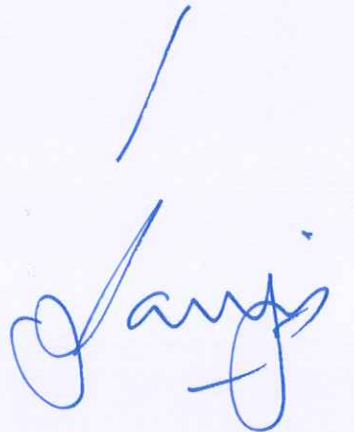



School of Automotive Skills
1st Semester, End-Sem. Examination
B. Voc. Program, Summer Semester (2020-21)

SRB

Set-B

Course Code: AUT1105

Course Name: Automotive Electrical Fundamentals & Comfort System

Section – A

10X01 = 10 Marks

1. The charging system:

Answer: d. All of the above.

2. Why do we use metallic shield for power cables in an automotive electrical?

Answer: c. To protect the wire from the external forces.

3. Calculate the total resistance between the points A and B.

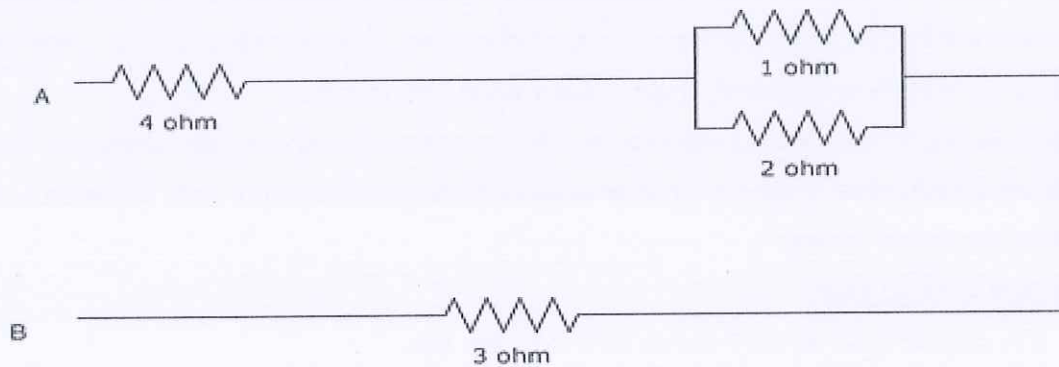

Answer: a. 8 ohms.

4. OBD used in scanning the sensor faults in an Automotive vehicle stands for....

Answer: d. On-Board Diagnostic.

5. Which one of the following component is not a part of an electronic component?

Answer: c. Wire.

6. Among the below options which material is a bad conductor of electricity?

Answer: a. Glass.

7. What are the modes of Heat transfer in a thermodynamic system?

Answer: c. Conduction, Convection and Radiation.

8. Which measuring instrument is commonly used in the automotive workshops for auto-electrical measurements?

Answer: d. Multimeter.

9. What is the purpose of a Drain Wire in an electrical cable?

Answer: d. To reduce the magnetic effect of positive and negative wire in a cable.



BHARTIYA SKILL DEVELOPMENT UNIVERSITY

10. Mixed-Signal Circuits in an Automotive electronics is also known as.....

Answer: d. Hybrid Circuits.

Section – B

04X04 = 16 Marks

11. Explain the function of an OBD-II Scanning Tool. Name any three parameters of an OBD-II Scanning Tool used in an Automotive Workshop.

Answer:

On-board diagnostics (OBD) is an automotive term referring to a vehicle's self-diagnostic and reporting capability. OBD systems give the vehicle owner or repair technician access to the status of the various vehicle subsystems.

The amount of diagnostic information available via OBD has varied widely since its introduction in the early 1980s versions of on-board vehicle computers. Early versions of OBD would simply illuminate a malfunction indicator light or "idiot light" if a problem was detected but would not provide any information as to the nature of the problem.

Modern OBD implementations use a standardized digital communications port to provide real-time data in addition to a standardized series of diagnostic trouble codes (DTCs) which allow one to rapidly identify and remedy malfunctions within the vehicle.

Various tools are available that plug into the OBD connector to access OBD functions. These range from simple generic consumer level tools to highly sophisticated OEM dealership tools to vehicle telematics devices.

Applications of OBD Tool:

1. It is used to read all diagnostics data from the car.
2. It has Mobile device-based tools and analysis, PC-based scan tools and analysis platforms, Data Loggers, Emission Testing, Driver's supplementary vehicle instrumentation, vehicle telematics.
3. Used to monitor real-time data like:
 - a. Engine temperature.
 - b. Fuel rate.
 - c. O2 sensor voltage.
 - d. Battery voltage level.
 - e. Time your engine has been running, etc.

12. Solve the following problems:

- a) One cable is damaged on the insulation. A residual current of 8.5A flows at a voltage of 24V. What is the resistance at the damaged area?
- b) If 500A flow at 250V, then what will be the resistance in the circuit?

Answer:

- a. Given: $V = 24V$, $I = 8.5A$.
w.k.t. $V = IR$,



BHARTIYA SKILL DEVELOPMENT UNIVERSITY

$$R = V/I = 24/8.5 = 2.82\text{ohms.}$$

b. Given: $V = 250\text{ V}$, $I = 500\text{ A}$.

w.k.t. $V = IR$,

$$R = V/I = 250/500 = 0.5\text{ ohms.}$$

13. Define the following:

- a. Coefficient of performance.
- b. Heat Engine.
- c. Heat Pump.
- d. Refrigerator.

Answer:

- a. Coefficient of performance: A refrigeration system's coefficient of performance (CoP) is very important in determining a system's overall efficiency. It is defined as refrigeration capacity in kW divided by the energy input in kW. While CoP is a very simple measure of performance, it is typically not used for industrial refrigeration in North America. Owners and manufacturers of these systems typically use performance factor (PF). A system's PF is defined as a system's energy input in horsepower divided by its refrigeration capacity in TR. Both CoP and PF can be applied to either the entire system or to system components. For example, an individual compressor can be rated by comparing the energy needed to run the compressor versus the expected refrigeration capacity based on inlet volume flow rate. It is important to note that both CoP and PF for a refrigeration system are only defined at specific operating conditions, including temperatures and thermal loads.
- b. Heat Engine: In thermodynamics and engineering, a heat engine is a system that converts heat or thermal energy—and chemical energy—to mechanical energy, which can then be used to do mechanical work. It does this by bringing a working substance from a higher state temperature to a lower state temperature. A heat source generates thermal energy that brings the working substance to the high temperature state. The working substance generates work in the working body of the engine while transferring heat to the colder sink until it reaches a low temperature state. During this process some of the thermal energy is converted into work by exploiting the properties of the working substance. The working substance can be any system with a non-zero heat capacity, but it usually is a gas or liquid. During this process, some heat is normally lost to the surroundings and is not converted to work.
- c. Heat Pump: A heat pump is a device that transfers heat energy from a source of heat to what is called a thermal reservoir. Heat pumps move thermal energy in the opposite

BHARTIYA SKILL DEVELOPMENT UNIVERSITY

direction of spontaneous heat transfer, by absorbing heat from a cold space and releasing it to a warmer one. A heat pump uses external power to accomplish the work of transferring energy from the heat source to the heat sink. The most common design of a heat pump involves four main components – a condenser, an expansion valve, an evaporator and a compressor. The heat transfer medium circulated through these components is called refrigerant.

- d. Refrigerator: A refrigerator (colloquially fridge) consists of a thermally insulated compartment and a heat pump (mechanical, electronic or chemical) that transfers heat from the inside of the fridge to its external environment so that the inside of the fridge is cooled to a temperature below the room temperature. Refrigeration is an essential food storage technique in developed countries. The lower temperature lowers the reproduction rate of bacteria, so the refrigerator reduces the rate of spoilage. A refrigerator maintains a temperature a few degrees above the freezing point of water. Optimum temperature range for perishable food storage is 3 to 5 °C (37 to 41 °F). A similar device that maintains a temperature below the freezing point of water is called a freezer. The refrigerator replaced the icebox, which had been a common household appliance for almost a century and a half.

14. Draw a schematic diagram of a simple VCRS cycle.

Answer:

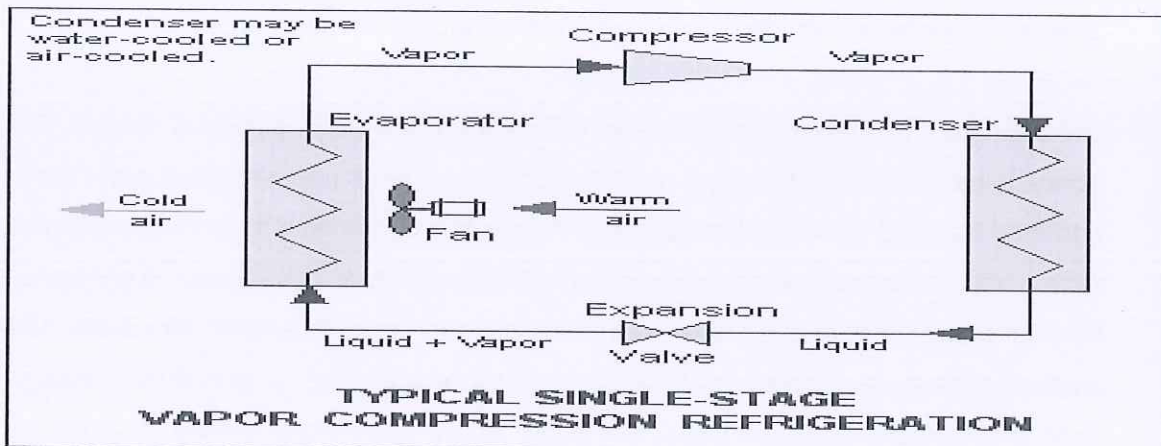

Section – C

04X06 = 24 Marks

15. Define AC Compressor, Condenser & Evaporator in detail.

Answer:

AC Compressor: The function of a compressor is to remove the vapour produced by the evaporator and to deliver it at a required higher pressure. The compressor can be compared to a heart pumping the blood (the refrigerant) inside the body (the compression cycle). In the basic compression cycle, the compressor is positioned between the evaporator and the



BHARTIYA SKILL DEVELOPMENT UNIVERSITY

condenser. Compressors can be installed in either single or multistage configuration, and can be connected to each other in series or in parallel.

The compressor is one of the most important parts of your air conditioning unit. Not only does the compressor play an important role in the cooling process, but it also ensures that the unit works effectively and continually.

Compressor Location

The compressor can be found under the hood (Bonnet) of the vehicle, near to the belt drive.

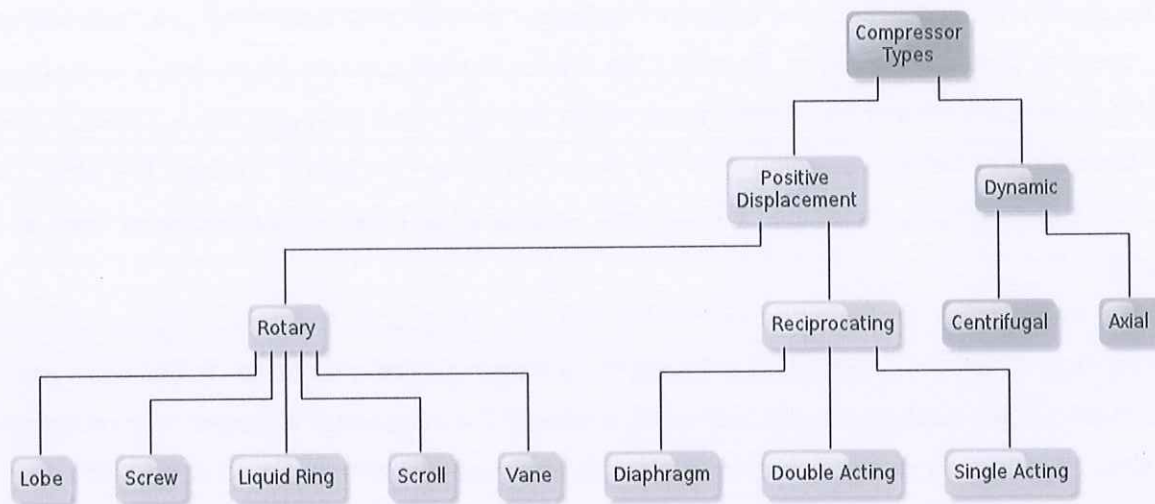

AC Condenser: In systems involving heat transfer, a condenser is a device or unit used to condense a gaseous substance into a liquid state through cooling. In so doing, the latent heat is released by the substance and transferred to the surrounding environment. Condensers are used for efficient heat rejection in many industrial systems. Condensers can be made according to numerous designs, and come in many sizes ranging from rather small (hand-held) to very large (industrial-scale units used in plant processes). For example, a refrigerator uses a condenser to get rid of heat extracted from the interior of the unit to the outside air.

Condensers are used in air conditioning, industrial chemical processes such as distillation, steam power plants and other heat-exchange systems. Use of cooling water or surrounding air as the coolant is common in many condensers.

A condenser is designed to transfer heat from a working fluid (e.g. water in a steam power plant) to a secondary fluid or the surrounding air. The condenser relies on the efficient heat transfer that occurs during phase changes, in this case during the condensation of a vapour into a liquid. The vapour typically enters the condenser at a temperature above that of the secondary fluid. As the vapour cools, it reaches the saturation temperature, condenses into liquid and releases large quantities of latent heat. As this process occurs along the condenser, the quantity of vapour decreases and the quantity of liquid increases; at the outlet of the condenser, only liquid remains. Some condenser designs contain an additional length to sub-cool this condensed liquid below the saturation temperature.



Types of condenser:

- Air-cooled Condenser.
- Water-cooled Condenser.
- Evaporative Condenser.

Evaporator: An evaporator is a device in a process used to turn the liquid form of a chemical substance such as water into its gaseous-form/vapour. The liquid is evaporated, or vaporized, into a gas form of the targeted substance in that process.

The air-conditioning evaporator is a small radiator inside the dashboard that provides cold air for the air-conditioning system. It's called the evaporator because it's where the freezing liquid refrigerant takes on any heat from the air blown through it and changes into a gaseous state (evaporating it) before returning it to the air-conditioning condenser to shed the heat; the process is constantly repeated. The air that emerges from the air conditioner is cold as a result.

The evaporator is typically hidden inside the vehicle's dashboard and can be labour-intensive to replace, which then requires a full system recharge. Unlike a ruptured heater core, which can leak engine coolant into the foot wells, a leak in the evaporator releases only refrigerant vapour. A clogged drainage channel is a common cause of water in the front foot wells.

Types of Evaporator:

- Natural/forced Circulation Evaporator.
- Falling Film Evaporator.
- Rising Film (Long Tube Vertical) Evaporator.
- Climbing and Falling-film Plate Evaporators.
- Multiple Effect Evaporators.
- Agitated Thin Film Evaporator.

16. Explain the following refrigerants and their properties:

- a. HFC.
- b. FC.
- c. HCFC.
- d. CO₂.
- e. NH₃.
- f. HC.

Answer:

- a. HFC: HydroFluoroCarbons

The hydrofluorocarbons are refrigerants that contain no chlorine and are not harmful to the ozone layer. However, their impact on global warming is very large compared



BHARTIYA SKILL DEVELOPMENT UNIVERSITY

with traditional refrigerants. The most common HFC refrigerants available since the ban on HCFCs are presented.

b. FC: FluoroCarbons

Fluorocarbons contain no chlorine and are not harmful to the ozone layer. However, they are extremely stable, and they have a high GWP. R218 is an example of a fluorocarbon, and FCs are also present in the mixtures R403 and R408.

c. HCFC: HydroChloroFluoroCarbons

The slow phase-out of CFCs shows it is a costly process. However, and more importantly, it also shows the problems and indecisiveness surrounding the availability of HCFCs, which were officially indicated as temporary (until 2030) substitutes for CFCs. The hasty actions of the European Union that culminated in the ban of HCFCs, immediately for refrigeration and soon (2004 at the latest) for air conditioning, has upset the industry's programs and plans.

The HCFCs contain less chlorine than CFCs, which means a lower ODP. Examples of hydrochlorofluorocarbons include R22, R123 and R124.

d. CO₂: Carbon Dioxide

R744, carbon dioxide, has several attractive characteristics: non-flammable, does not cause ozone depletion, very low toxicity index (safety A1), available in large quantities, and low cost. However, it also has a low efficiency and a high operating pressure (approximately 10 times higher than R134a). For the two latter reasons, efforts are needed to improve its refrigeration cycle and related technology, particularly heat exchangers and expansion devices. A major forthcoming CO₂ application seems to be air conditioning in the automotive industry. Heat pumps could also benefit from CO₂ due to the higher temperature that can be obtained even at very low ambient temperatures.

e. NH₃: Ammonia

Ammonia, R717, is an attractive refrigerant alternative. It has been used in refrigeration systems since 1840 and in vapour compression since 1860. In terms of its properties, it should be considered a high-class refrigerant. Furthermore, its ODP and GWP are 0. However, although it is a self-alerting gas, i.e. leaks can easily be detected by the smell, ammonia is very hazardous even at low concentrations because the smell often causes panic. This is the main reason why ammonia was withdrawn from applications for use by unskilled people and retained only for industrial applications.

It is also quite common in commercial refrigeration, although safety regulations require that it be used with a secondary distribution loop. Obviously, this secondary loop reduces the efficiency.

f. HC: HydroCarbons

Hydrocarbons are a very limited solution to the environmental problems associated with refrigerants. They are harmless to the ozone layer ($ODP = 0$) and have hardly any direct greenhouse effect ($GWP < 5$), but they are highly flammable. The use of HCs as refrigerants is confined to Europe, because many other countries elsewhere have banned the use of flammable gas in the presence of the public. According to the standards ISO 55149 and EN 378.2000, this should apply also in Europe.

However, the standard IEC 355.2.20 allows the use of HCs in household refrigerators with refrigerant charges up to 150 g.

This standard has opened the way for some European refrigerator manufacturers to produce household refrigerators with flammable isobutene, R600a.

These have been accepted enthusiastically by environmentalists, and have achieved great success in the market.

17. Write down the standard operating procedure of AC Gas Recycling through Bosch Robinair ACS 261.

Answer:

- The student should wear appropriate PPE's like safety goggles, safety gloves, earplugs, nose mask, etc. while working on Robinair ACS 261 A/C recycling machine.
- Check the power supply of the machine, it should be three phase.
- Check the cooling effect of the vehicle by temperature measuring instrument.
- Check the unwanted sound of the compressor.
- Check the compressor oil level (Top-up if required).
- Check the refrigerant amount from the refrigerant tank (if less then fill it up).
- Check the connections of the A/C line.
- Turn ON the machine.
- Connect the high pressure and low pressure valves with hose reel connectors.
- Select A/C Servicing.
- Select Manual / Auto Mode of A/C recycling.
- Select Recovery of refrigerant (PI Time of 1 minute), then select vacuuming of A/C System Line (Vacuum. Creation time for 20 minutes and Vacuum. Holding time for 5 minutes), Oil recharging (10 ml or *as per cabin size and vehicle manual specifications), Refrigerant charging (300 gm to 900 gm as per mentioned in the manual as per cabin size), Hose pipe draining.

Process:

Step 1: Start recovery of refrigerant gas from the A/c System.

Step 2: After recovery start vacuum creation and vacuum holding in the line of A/C System.

Step 3: After step 2, start refilling of the compressor oil and refrigerant in the A/C System.



BHARTIYA SKILL DEVELOPMENT UNIVERSITY

Step 4: After refilling, remove the hose connectors from the outlet valves, and start the hose draining process to ensure that no refrigerant gas should remain in the hose pipe of the Robinair ACS 261.

Step 5: Note down the summary screen of the Robinair ACS 261 for the final results of A/C Recycling in a vehicle to know the amount recovered and consumed & the time taken for the process to estimate the cost of job work.

Step 6: Switch OFF the machine and remove the power supply.

- Check the cooling effect of the vehicle by temperature measuring instrument after the process of recycling of refrigerant by turning ON the vehicle for 15 minutes.
- Check the workplace properly and manage it from the initial phase of the process for better working of the job.

18. Differentiate between series and parallel connections.

Solution:

The main difference between series and parallel circuits is that, in series circuits, all components are connected in series so that they all share the same current whereas, in parallel circuits, components are connected in parallel so that they all have the same potential difference between them.



School of Automotive Skills

1st Semester, End-Sem. Examination

Set A

B. Voc. Program, Summer Semester (2020-21)

Course Code: AUT1105

Set - A

Time: 2 Hours

Course Name: Automotive Electrical Fundamentals and Comfort System

Max. Marks: 50

Instruction:

1. Answer all questions from section – A, each question carries one mark.
2. Answer all questions from section – B, each question carries four marks.
3. Answer all questions from section – C, each question carries six marks.

Section – A

10X01 = 10 Marks

1. What type of specification is used to rate a transducer?
 - a. Transmitting Range.
 - b. Receiving Range.
 - c. Dynamic Range.
 - d. All of the above.
2. Flow of current is due to the:
 - a. Flow of electron
 - b. Drift of electron
 - c. Drift of free electron
 - d. None of the above
3. Which of the term in the following is not a property of refrigerant R134a?
 - a. High heat of vaporization.
 - b. Flammable.
 - c. Non-corrosive.
 - d. Non-toxic.
4. If in a circuit there are three resistors each of 120 ohms connected as two in series and one in parallel with those two, & with a battery of 12 V. Then what find out the total current of the circuit?
 - a. 15A.
 - b. 1.5A.
 - c. 115A.
 - d. 0.15A
5. What is the effect of voltage to current in a circuit?
 - a. Voltage increase while current increase.
 - b. Voltage decrease while current increase.
 - c. Voltage increase while current decrease.



- d. None of the above.
6. Who invented the voltaic pile?
- a. Alexander Graham Bell.
 - b. Alessandro Volta.
 - c. Albert Einstein.
 - d. A.P.J. Abdul Kalam.
7. What is the universally accepted cylinder code for R134a?
- a. Light Green.
 - b. Light Yellow.
 - c. Light Red.
 - d. Light Blue.
8. A parking light takes 0.5A current, its resistance is 24 Ω . What is the voltage of the lamp?
- a. 12 Volts.
 - b. 24 Volts.
 - c. 10 Volts.
 - d. 48 Volts.
9. Which of the following is not an application of an actuator?
- a. Electroactive Polymer.
 - b. Electropassive Polymer.
 - c. Thermal Bimorph.
 - d. Shape-memory Alloy.
10. The function of a compressor is to remove the vapor produced by the and to deliver it at a required pressure.
- a. Evaporator, Lower.
 - b. Evaporator, Higher.
 - c. Expansion Valve, Lower.
 - d. Expansion Valve, Higher.

Section – B

04X04 = 16 Marks

11. Define the following:
- a. Coefficient of performance.
 - b. Heat Engine.
 - c. Heat Pump.
 - d. Refrigerator.
12. Name any eight sensors with their function used in an automotive vehicle.
13. Write down the advantages and disadvantages of VCERS over Air Refrigeration System.
14. Explain Thermodynamic System.

Section – C

04X06 = 24 Marks

15. Write down the standard operating procedure of AC Gas Recycling through Bosch Robinair ACS 261.
16. Explain the following:
 - a. Electrostatic Effect.
 - b. Multimeter.
 - c. Relay.
17. Define AC Compressor, Condenser & Evaporator in detail.
18. Differentiate between series and parallel connections.



A handwritten signature in black ink, appearing to read 'Dang', is written in the center of the page.



School of Automotive Skills
1st Semester, End-Sem. Examination
B. Voc. Program, Summer Semester (2020-21)

SRLA

Set-A

Course Code: AUT1105

Course Name: Automotive Electrical Fundamentals & Comfort System

Section – A

10X01 = 10 Marks

1. What type of specification is used to rate a transducer?

Answer: c. Dynamic Range.

2. Flow of current is due to the:

Answer: c. Drift of free electron

3. Which of the term in the following is not a property of refrigerant R134a?

Answer: b. Flammable.

4. If in a circuit there are three resistors each of 120 ohms connected as two in series and one in parallel with those two, & with a battery of 12 V. Then what find out the total current of the circuit?

Answer: d. 0.15A.

5. What is the effect of voltage to current in a circuit?

Answer: a. Voltage increase while current increases.

6. Who invented the voltaic pile?

Answer: b. Alessandro Volta.

7. What is the universally accepted cylinder code for R134a?

Answer: d. Light Blue.

8. A parking light takes 0.5A current, its resistance is 24 Ω . What is the voltage of the lamp?

Answer: a. 12 Volts.

9. Which of the following is not an application of an actuator?

Answer: b. Electropassive Polymer.

10. The function of a compressor is to remove the vapour produced by the and to deliver it at a required pressure.

Answer: b. Evaporator, Higher.

Section – B

04X04 = 16 Marks

11. Define the following:

- Coefficient of performance.
- Heat Engine.
- Heat Pump.
- Refrigerator.

Answer:

- A refrigeration system's coefficient of performance (CoP) is very important in determining a system's overall efficiency. It is defined as refrigeration capacity in kW divided by the energy input in kW. While CoP is a very simple measure of performance, it is typically not used for industrial refrigeration in North America. Owners and manufacturers of these systems typically use performance factor (PF).
- In thermodynamics and engineering, a heat engine is a system that converts heat or thermal energy—and chemical energy—to mechanical energy, which can then be used to do mechanical work. It does this by bringing a working substance from a higher state temperature to a lower state temperature.

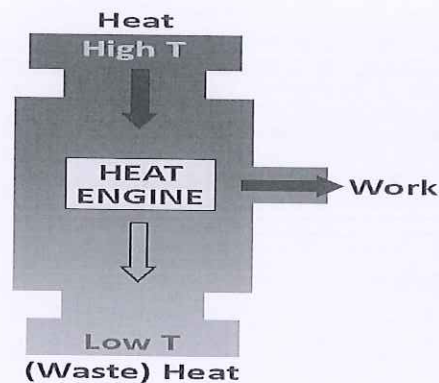

- A heat pump is a device that transfers heat energy from a source of heat to what is called a thermal reservoir. Heat pumps move thermal energy in the opposite direction of spontaneous heat transfer, by absorbing heat from a cold space and releasing it to a warmer one.
- A refrigerator (colloquially fridge) consists of a thermally insulated compartment and a heat pump (mechanical, electronic or chemical) that transfers heat from the inside of the fridge to its external environment so that the inside of the fridge is cooled to a

temperature below the room temperature. Refrigeration is an essential food storage technique in developed countries.

12. Name any eight sensors with their function used in an automotive vehicle.

Answer:

1. Crankshaft Position Sensor: The functional objective for the crankshaft position sensor is to determine the position and/or rotational speed (RPM) of the crank. Engine Control Units use the information transmitted by the sensor to control parameters such as ignition timing and fuel injection timing.
2. Engine Coolant Temperature Sensor: Coolant temperature sensors are used by the fuel management system to detect the engine's operating temperature. Depending on the sensor information, the control unit adapts the injection time and firing angle to the operating conditions.
3. Airbag Sensor: This airbag works as an inflatable seatbelt that inflates upon frontal impact from another vehicle. Activation of automotive airbags is triggered by crash sensors (also known as impact sensors) that work to detect frontal impact and trigger a control unit that deploys the airbag to cushion the passenger.
4. Camshaft Position Sensor: The purpose of a camshaft position sensor is to determine the position of the camshaft as it relates to the crankshaft. This data is then sent to the powertrain control module (PCM) for use with fuel injector and/or ignition system control.
5. Brake Fluid Pressure Sensor: The sensor has an input port to measure the hydraulic braking pressure and an electrical connector output for a wire connection for feeding the warning light. Some brake failures do not trip the sensor into a fault mode. A brake fluid pressure sensor is used in anti-lock braking system (ABS).
6. Knock Sensor: The knock sensor is located on the engine block, cylinder head or intake manifold. This is because its function is to sense vibrations caused by engine knock or detonation. The PCM uses this signal to alter the ignition timing and prevent detonation. Be clear that this sensor affects the ignition timing of an engine.
7. MAP Sensor: The Manifold Absolute Pressure (MAP) sensor is a key sensor because it senses engine load. The sensor generates a signal that is proportional to the amount of vacuum in the intake manifold. The engine computer then uses this information to adjust ignition timing and fuel enrichment.
8. Oxygen Sensor: The O₂ sensor is mounted in the exhaust manifold to monitor how much unburned oxygen is in the exhaust as the exhaust exits the engine. Monitoring oxygen levels in the exhaust is a way of gauging the fuel mixture. It tells the computer if the fuel mixture is burning rich (less oxygen) or lean (more oxygen).

13. Write down the advantages and disadvantages of VCRS over Air Refrigeration System.

Answer:

Advantages:

- Size is small when compared to an air refrigeration system for a given capacity of refrigeration.
- Volume of refrigerant circulated is low. Hence the running cost is low.
- High coefficient of performance.
- The operating temperature range is huge.
- The temperature at the evaporator can be easily controlled by regulating expansion valve.
- It requires smaller evaporator.

Disadvantages:

- High initial cost, costly refrigerant.
- Environmental hazardous refrigerant involved.
- Must ensure the prevention of leakage of refrigerant.

14. Explain Thermodynamic System.

Answer:

- A thermodynamic system is a group of material and/or radiative contents. Its properties may be described by thermodynamic state variables such as temperature, entropy, internal energy, and pressure.
- The simplest state of a thermodynamic system is a state of thermodynamic equilibrium, as opposed to a non-equilibrium state. A system is defined as quantity of matter or a region in space chosen for study. Everything external to the system is surrounding. Thermodynamic system and surrounding is always separated by the boundary.



- The system can be separated from its surrounding by a wall or without a wall.
- When the state of its content varies in space, the system can be considered as many systems located next to each other, each being a different thermodynamical system.
- A thermodynamic system is subject to external interventions called thermodynamic operations; these alter the system's walls or its surroundings; as a result, the system undergoes thermodynamic processes according to the principles of thermodynamics. (This account mainly refers to the simplest kind of thermodynamic system; compositions of simple systems may also be considered.)

Section – C

04X06 = 24 Marks

15. Write down the standard operating procedure of AC Gas Recycling through Bosch Robinair ACS 261.

Answer:

- The student should wear appropriate PPE's like safety goggles, safety gloves, earplugs, nose mask, etc. while working on Robinair ACS 261 A/C recycling machine.
- Check the power supply of the machine, it should be three phase.
- Check the cooling effect of the vehicle by temperature measuring instrument.
- Check the unwanted sound of the compressor.
- Check the compressor oil level (Top-up if required).
- Check the refrigerant amount from the refrigerant tank (if less then fill it up).
- Check the connections of the A/C line.
- Turn ON the machine.
- Connect the high pressure and low pressure valves with hose reel connectors.
- Select A/C Servicing.
- Select Manual / Auto Mode of A/C recycling.
- Select Recovery of refrigerant (PI Time of 1 minute), then select vacuuming of A/C System Line (Vacuum. Creation time for 20 minutes and Vacuum. Holding time for 5 minutes), Oil recharging (10 ml or *as per cabin size and vehicle manual specifications), Refrigerant charging (300 gm to 900 gm as per mentioned in the manual as per cabin size), Hose pipe draining.

Process:

Step 1: Start recovery of refrigerant gas from the A/c System.

Step 2: After recovery start vacuum creation and vacuum holding in the line of A/C System.

Step 3: After step 2, start refilling of the compressor oil and refrigerant in the A/C System.

Step 4: After refilling, remove the hose connectors from the outlet valves, and start the hose draining process to ensure that no refrigerant gas should remain in the hose pipe of the Robinair ACS 261.

Step 5: Note down the summary screen of the Robinair ACS 261 for the final results of A/C Recycling in a vehicle to know the amount recovered and consumed & the time taken for the process to estimate the cost of job work.

Step 6: Switch OFF the machine and remove the power supply.

- Check the cooling effect of the vehicle by temperature measuring instrument after the process of recycling of refrigerant by turning ON the vehicle for 15 minutes.

- Check the workplace properly and manage it from the initial phase of the process for better working of the job.

16. Explain the following:

- a. Electrostatic Effect.
- b. Multimeter.
- c. Relay.

Answer:

- a. **Electrostatic effects:** Electrostatics is a branch of physics that studies electric charges at rest. Since classical physics, it has been known that some materials such as amber attract lightweight particles after rubbing. The Greek word for amber, or electron, was the source of the word 'electricity'. Electrostatic phenomena arise from the forces that electric charges exert on each other. Such forces are described by Coulomb's law. Even though electrostatically induced forces seem to be rather weak, some electrostatic forces such as the one between an electron and a proton, that together make up a hydrogen atom, is about 36 orders of magnitude stronger than the gravitational force acting between them.
- b. **Multimeter:** A multimeter or a multitester, also known as a VOM (volt-ohm-milli-ammeter), is an electronic measuring instrument that combines several measurement functions in one unit. A typical multimeter can measure voltage, current, and resistance. Analog multimeters uses a micro-ammeter with a moving pointer to display readings. Digital multimeters (DMM, DVOM) have a numeric display, and may also show a graphical bar representing the measured value. Digital multimeters are now far more common due to their lower cost and greater precision, but analog multimeters are still preferable in some cases, for example when monitoring a rapidly varying value.
- c. **Relays** are switches that open and close circuits electromechanically or electronically. Relays control one electrical circuit by opening and closing contacts in another circuit. As relay diagrams show, when a relay contact is normally open (NO), there is an open contact when the relay is not energized. When a relay contact is Normally Closed (NC), there is a closed contact when the relay is not energized. In either case, applying electrical current to the contacts will change their state.

Relays are generally used to switch smaller currents in a control circuit and do not usually control power consuming devices except for small motors and Solenoids that draw low amps. Nonetheless, relays can "control" larger voltages and amperes by having an amplifying effect because a small voltage applied to a relays coil can result in a large voltage being switched by the contacts.

17. Define AC Compressor, Condenser & Evaporator in detail.

Answer:

- a. The function of a compressor is to remove the vapour produced by the evaporator and to deliver it at a required higher pressure. The compressor can be compared to a heart pumping the blood (the refrigerant) inside the body (the compression cycle). In the basic compression cycle, the compressor is positioned between the evaporator and the condenser. Compressors can be installed in either single or multistage configuration, and can be connected to each other in series or in parallel. The compressor is one of the most important parts of your air conditioning unit. Not only does the compressor play an important role in the cooling process, but it also ensures that the unit works effectively and continually. Compressor Location: The compressor can be found under the hood (Bonnet) of the vehicle, near to the belt drive.

Types of Compressors:

- Positive Displacement Compressor (reduction in volume due to a piston in thermodynamics is considered as positive displacement of the piston).
 - Reciprocating or piston type compressor.
 - Screw compressor.
 - Scroll compressor.
 - Rotary compressor.
 - Dynamic compressor.
 - Centrifugal or turbo compressor.
- b. In systems involving heat transfer, a condenser is a device or unit used to condense a gaseous substance into a liquid state through cooling. In so doing, the latent heat is released by the substance and transferred to the surrounding environment. Condensers are used for efficient heat rejection in many industrial systems. Condensers can be made according to numerous designs, and come in many sizes ranging from rather small (hand-held) to very large (industrial-scale units used in plant processes). For example, a refrigerator uses a condenser to get rid of heat extracted from the interior of the unit to the outside air.

Condensers are used in air conditioning, industrial chemical processes such as distillation, steam power plants and other heat-exchange systems. Use of cooling water or surrounding air as the coolant is common in many condensers.

Types of Condensers:

- Air-cooled Condenser.
- Water-cooled Condenser.
- Evaporative Condenser.

- c. An evaporator is a device in a process used to turn the liquid form of a chemical substance such as water into its gaseous-form/vapour. The liquid is evaporated, or vaporized, into a gas form of the targeted substance in that process.

The air-conditioning evaporator is a small radiator inside the dashboard that provides cold air for the air-conditioning system. It's called the evaporator because it's where the freezing liquid refrigerant takes on any heat from the air blown through it and changes into a gaseous state (evaporating it) before returning it to the air-conditioning condenser to shed the heat; the process is constantly repeated. The air that emerges from the air conditioner is cold as a result.

The evaporator is typically hidden inside the vehicle's dashboard and can be labour-intensive to replace, which then requires a full system recharge. Unlike a ruptured heater core, which can leak engine coolant into the foot wells, a leak in the evaporator releases only refrigerant vapour. A clogged drainage channel is a common cause of water in the front foot wells.

Types of Evaporator:

- Natural/forced Circulation Evaporator.
- Falling Film Evaporator.
- Rising Film (Long Tube Vertical) Evaporator.
- Climbing and Falling-film Plate Evaporators.
- Multiple Effect Evaporators.
- Agitated Thin Film Evaporator.

18. Differentiate between series and parallel connections.

Solution:

The main difference between series and parallel circuits is that, in series circuits, all components are connected in series so that they all share the same current whereas, in parallel circuits, components are connected in parallel so that they all have the same potential difference between them.



School of Automotive Skills
Session: 2020-21 (Summer Semester)
B. Voc. Program, 1st Semester,
End-Sem. Examination

Set A

Course Code: AUT1106

Time: 2 Hour

Course Name: Automotive Tools & Measurement

Max. Marks: 50

Instruction:

1. Answer all questions from section A, each question carries one mark.
2. Answer all questions from section B, each question carries four mark.
3. Answer all questions from section C, each question carries six mark.

Section – A

10X01 = 10 Marks

Q-1. The least count defines the.....

- | | |
|---------------------------------|--------------------|
| a. Smallest unit we can measure | c. Smallest length |
| b. Smallest dimension | d. None of these |

Q-2. Which type of measurement does not provide numerical values?

- | | |
|--------------|----------------------|
| a. Gauging | c. Both (A) & (B) |
| b. Measuring | d. None of the above |

Q-3. In engineering drawing second & fourth angle projections are not used because of:

- | | |
|------------------|----------------------|
| a. Overlapping | c. Lacking |
| b. Complications | d. None of the above |

Q-4. Which one of the following ratios represents the reducing scale?

- | | |
|--------|---------|
| a. 1:1 | c. 2:1 |
| b. 1:2 | d. 10:2 |

Q-5. Which value can be the reading of an instrument having least count = $20\mu\text{m}$?

- | | |
|-----------|-----------|
| a. 20.05 | c. 20.06 |
| b. 20.062 | d. 20.006 |

Q-6. In first angle projection object is kept between observer & plane of projection:

- a. True.
- b. False.
- c. None of the above.



Q-7. Tolerance can be defined as:

- a. Permissible variation of specified dimension.
- b. Unilateral dimension.
- c. Bi-Lateral dimension.
- d. Both (a) & (b).

Q-8. A view is obtained making an imaginary cut through the part.

- a. Front View.
- b. Side View.
- c. Sectional View.
- d. Top View.

Q-9. When the tolerance distribution is only on one side of the basic size, it is known as:

- a. Unilateral tolerance.
- b. Bilateral tolerance.
- c. None of the above.

Q-10. Which value can be the reading of an instrument having least count = $50\mu\text{m}$?

- a. 19.05
- b. 18.062
- c. 19.06
- d. 18.006

Section – B

04X04 = 16 Marks

Q-1. What is hammer? Also write name of the components.

Q-2. Describe types of chisel angle.

Q-3. Calculate the least count of a Vernier Caliper, the 49 division of main scale is coinciding with 50 divisions of Vernier scale (MSD = 1 mm).

Q-4. Name the instruments & accessories used for technical drawing.

Section – C

04X06 = 24 Marks

Q-1. Write requirement of clamps, also explain types of clamps.

Q-2. What is chisel? Explain different types of chisel

Q-3. Explain pliers and snips.

Q-4. Differentiate between first angle projection & third angle projection.



School of Automotive Skills
Session: 2020-21 (Summer Semester)
B. Voc. Program, 1st Semester,
End-Sem. Examination

Set-A

Course Code: AUT1106

Set-A Answer Key

Time: 2 Hour

Course Name: Automotive Tools & Measurement

Max. Marks: 50

Instruction:

1. Answer all questions from section A, each question carries one mark.
2. Answer all questions from section B, each question carries four mark.
3. Answer all questions from section C, each question carries six mark.

Section – A

10X01 = 10 Marks

Q-1. The least count defines the.....

- | | |
|--|--------------------|
| a. Smallest unit we can measure | c. Smallest length |
| b. Smallest dimension | d. None of these |

Q-2. Which type of measurement does not provide numerical values?

- | | |
|-------------------|----------------------|
| a. Gauging | c. Both (A) & (B) |
| b. Measuring | d. None of the above |

Q-3. In engineering drawing second & fourth angle projections are not used because of:

- | | |
|-----------------------|----------------------|
| a. Overlapping | c. Lacking |
| b. Complications | d. None of the above |

Q-4. Which one of the following ratios represents the reducing scale?

- | | |
|---------------|---------|
| a. 1:1 | c. 2:1 |
| b. 1:2 | d. 10:2 |

Q-5. Which value can be the reading of an instrument having least count = $20\mu\text{m}$?

- | | |
|-----------|-----------------|
| a. 20.05 | c. 20.06 |
| b. 20.062 | d. 20.006 |

Q-6. In first angle projection object is kept between observer & plane of projection:

- a. **True.**
- b. False.
- c. None of the above.

Q-7. Tolerance can be defined as:

- a. **Permissible variation of specified dimension.**
- b. Unilateral dimension.
- c. Bi-Lateral dimension.
- d. Both (a) & (b).

Q-8. A view is obtained making an imaginary cut through the part.

- a. Front View.
- b. Side View.
- c. Sectional View.
- d. Top View.

Q-9. When the tolerance distribution is only on one side of the basic size, it is known as:

- a. **Unilateral tolerance.**
- b. Bilateral tolerance.
- c. None of the above.

Q-10. Which value can be the reading of an instrument having least count = $50\mu\text{m}$?

- a. **19.05**
- b. 18.062
- c. 19.06
- d. 18.006

Section – B

04X04 = 16 Marks

Q-1. What is hammer? Also write name of the components.

Ans:

HAMMERS: -

- An engineer's hammer is a hand tool used for striking purposes while:
 - Punching
 - Bending
 - Chipping
 - Forging
 - Riveting

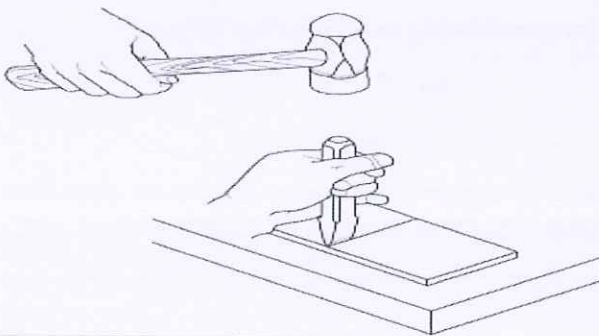

MAJOR PARTS OF HAMMER: -

- The major parts of hammer are hammer head and a handle
- The head is made of drop forged carbon steel, while wooden handle must be capable of absorbing shocks
- The parts of hammer head are:

- Face
- Peen
- Cheek
- Eyehole
- Wedge

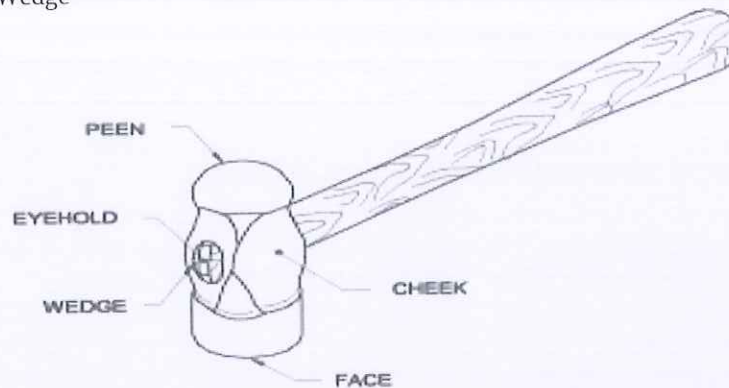

Q-2. Describe types of chisel angle.

Ans:

ANGLES OF CHISELS:-

Point Angle:

Correct point/cutting angles of chisel depends on the material to be chipped, sharp angles for soft materials and wide angles for hard materials

Rake Angle:

Rake angle is angle between the top face of cutting point and normal to work surface at cutting edge

Clearance Angle:

Clearance angle is angle between the bottom face of point and tangent to the work surface originating at the cutting edge

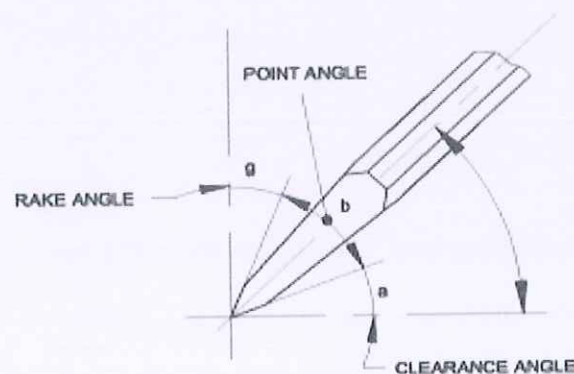

Q-3. Calculate the least count of a Vernier Caliper, the 49 division of main scale is coinciding with 50 divisions of Vernier scale (MSD = 1 mm).

Ans:

Q-4. Name the instruments & accessories used for technical drawing.

Ans:

- e. Drawing Board.



- f. Drawing sheet.
- g. Mini-drafter.
- h. Set Squares.
- i. Compasses.
- j. Divider.
- k. Pencils/ lead sticks/ pencil sharpener/ eraser, etc.

Section – C

04X06 = 24 Marks

Q-1. Write requirement of clamps, also explain types of clamps.

Ans:

Clamps are used for preventing the movement of work and for holding the job tight

Requirements of clamping devices

Should be able to manipulate for easy loading

Should provide the required clamping force

Should be capable of locking with minimum movement

Should accommodate a range of sizes of jobs

A typical clamping device employs a screw and nut

to provide the clamping force

1. C- CLAMPS:

These clamps are in the shape of C

The C clamp has its body forged or cast

One end of clamp is machined flat

The other end is drilled and threaded to accommodate a screw rod which is operated by a handle

The screw rod carries a swivel pad which is free to revolve

The clamp is hardened and face is serrated

Used for:

On an angle plate

Drill press table

Two or more work piece together

2. TOOL MAKER'S CLAMPS: Most commonly used by tool makers for holding small machined flat pieces

Two rectangular pieces of steel perfectly machined and inner faces coming in contact with job perfectly parallel

They are assembled by means of two threaded rods

Screw rod A –to adjust gap between two holding faces

Screw rod B- tightened to maintain required pressure (hole in head for passing cylindrical pin for tightening purpose)

Used for holding previously machined work which is flat and parallel

Also known as parallel clamp

Q-2. What is chisel? Explain different types of chisel

Ans:

TYPES OF CHISELS:

- Common types of Chisels are:
 - Flat Chisel
 - Cross Cut or Cape Chisel
 - Half Round Nose Chisel
 - Diamond Point Chisel
 - Web or Punching Chisel
- A chisel is specified according to their
 - Length
 - Width of cutting edge
 - Type
 - Cross section of body
- The length ranges from 150 mm to 400mm
- The width of cutting edge varies according to type of chisels
- 1. **Flat chisel:** - They are used to remove the metal from large flat surfaces and to chip excess metal from weld joints and castings
- 2. **Cross cut chisel:** - They are used for cutting keyways, grooves and slots

g 3

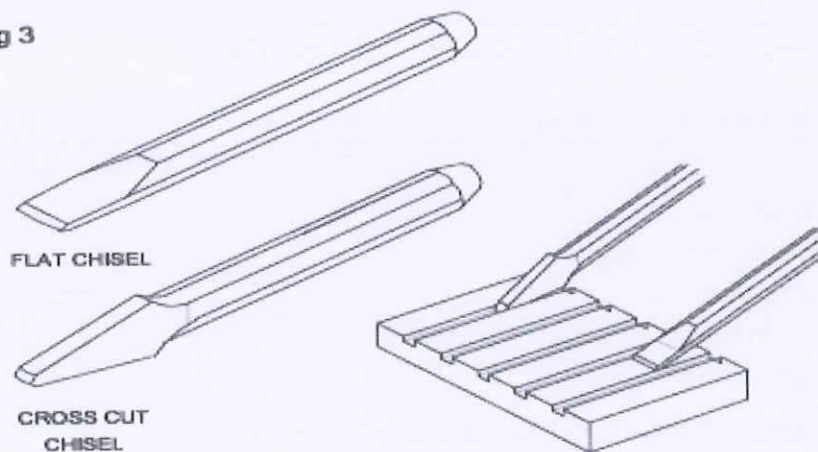

- 3. **Half round chisel:** - Half Round Nose chisels are used for cutting grooves .

Fig 4

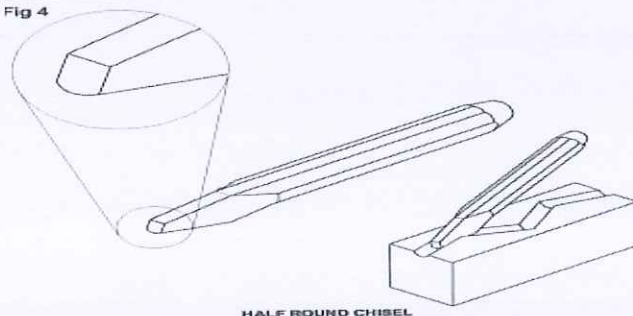

4. **Diamond point chisel:** - Diamond Point chisels are used for squaring materials at the corners.

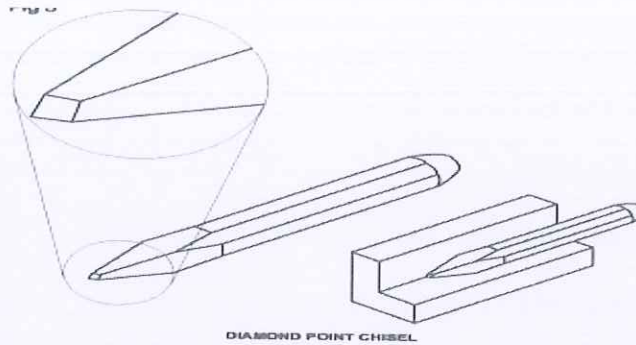

5. **Web/punching chisel:** - Web/ Punching Chisels are used for separating metals after chain drilling.

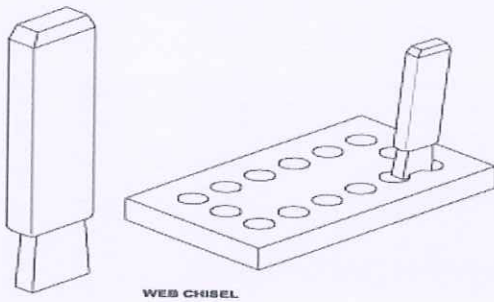

Q-3. Explain pliers and snips.

Ans:

Pliers have a pair of legs joined by a pivot, hinge or fulcrum pin (combination pliers)

Each leg consists of long handle and a short jaw

Elements of pliers:

Flat Jaw: Serrated for general gripping

Pipe Grip: serrated for gripping cylindrical objects

Side Cutters: for cutting off soft wires

Joint Cutters: two joint cutters for cutting or shearing off steel wires

Handles: for applying pressure by hand

Available in sizes from 150 mm to 230 mm (Size = Overall length)

1. Flat Nose Pliers has tapered jaws with flat gripping surfaces which may be either smooth or serrated

It is used for bending and folding narrow strips of thin jobs.

2. ROUND NOSE PLIERS

This type of pliers is made with tapered round shape

They are used to shape loops in wires and form curves in light metal strips

3. SLIP- JOINT PLIERS:

These pliers are available in different ranges of positions with different shapes of pivot pins so that they have various range of jaw opening

Mainly used for gripping

4. END CUTTING 7 SIDE CUTTING.

They are used for shearing off wires in confined spaces and cutting of wires close to surface level

They are also used for spreading the cotter pin

5. INTERNAL & EXTERNAL CIRCLIP PLIERS

6. SLIP-JOINT, MULTI GRIP PLIERS

SNIP:

A snip also called a hand shear is used like a pair of scissors to cut thin, soft metal sheets.

Snips are used to cut sheet metal up-to 1.2 mm thickness.

There are several types of snips available for making straight or circular cuts.

The most common snips are straight snips and curved/bent snips.

The choice of snips depends on the shape and type of cut required

Snips are specified by overall length and shape of the blade

1. STRAIGHT SNIPS

These are used for making straight cuts and large external curves

Straight snips have thin blades which are strongly on vertical planes

They are therefore only suitable for straight cuts and external curves when surplus waste has to be removed

While cutting the blade of the snips should not cover the marking

2. BENT SNIPS

These snips have curved blades for making circular cuts

They are also used for trimming cylindrical or conical work in sheet metal

They are therefore only suitable for circular/conical cuts and curves when surplus waste has to be removed

While cutting the blade of the snips should not cover the marking

Q-4. Differentiate between first angle projection & third angle projection.

Ans:

First angle projection	Third angle projection
Object is kept in the first quadrant	Object is assumed to be kept in third quadrant
Object lies between observer and the plane of projection	Plane of projection lies between the observer and the object.
The plane of projection is assumed to be non-transparent	The plane of projection is assumed to be transparent
Front (elevation) view is drawn above the XY line	Front (elevation) view is drawn below the XY line
Top (plane) view is drawn below the XY line	Top (plane) view is drawn above the XY line
Left view is projected on the right plane & vice versa	Left view is projected on the left plane itself.
Followed in India, European countries.	Followed in USA.



School of Automotive Skills
Session: 2020-21 (Summer Semester)
B. Voc. Program, 1st Semester,
End-Sem. Examination

Set B

Course Code: AUT1106

Set-B

Time: 2 Hour

Course Name: Automotive Tools & Measurement

Max. Marks: 50

Instruction:

1. Answer all questions from section A, each question carries one mark.
2. Answer all questions from section B, each question carries four mark.
3. Answer all questions from section C, each question carries six mark.

Section – A

10X01 = 10 Marks

Q-1. The least count defines the.....

- | | |
|---------------------------------|--------------------|
| a. Smallest unit we can measure | c. Smallest length |
| b. Smallest dimension | d. None of these |

Q-2. Which type of measurement does not provide numerical values?

- | | |
|--------------|----------------------|
| a. Gauging | c. Both (A) & (B) |
| b. Measuring | d. None of the above |

Q-3. In engineering drawing second & fourth angle projections are not used because of:

- | | |
|------------------|----------------------|
| a. Overlapping | c. Lacking |
| b. Complications | d. None of the above |

Q-4. Which one of the following ratios represents the reducing scale?

- | | |
|--------|---------|
| a. 1:1 | c. 2:1 |
| b. 1:2 | d. 10:2 |

Q-5. Which value can be the reading of an instrument having least count = 20 μ m ?

- | | |
|-----------|-----------|
| a. 20.05 | c. 20.06 |
| b. 20.062 | d. 20.006 |

Q-6. In first angle projection object is kept between observer & plane of projection:

- a. True.
- b. False.
- c. None of the above.

Q-7. Tolerance can be defined as:

- | | |
|--|--------------------------|
| a. Permissible variation of specified dimension. | c. Unilateral dimension. |
| b. Bi-Lateral dimension. | d. Both (a) & (c). |



BHARTIYA SKILL DEVELOPMENT UNIVERSITY

Q-8. A view is obtained making an imaginary cut through the part.

- a. Front View.
- b. Side View.
- c. Sectional View.
- d. Top View.

Q-9. When the tolerance distribution is only on one side of the basic size, it is known as:

- a. Unilateral tolerance.
- b. Bilateral tolerance.
- c. None of the above.

Q-10. Which value can be the reading of an instrument having least count = $50\mu\text{m}$?

- a. 19.05
- b. 18.062
- c. 19.06
- d. 18.006

Section – B

04X04 = 16 Marks

Q-1. Describe types of nuts.

Q-2. Write a short note on spanners.

Q-3. What is hammer? Also write name of the components.

Q-4. Write at least 4 differences between tools and equipment's.

Section – C

04X06 = 24 Marks

Q-1. Explain pliers and snips.

Q-2. What is screw? Explain different types of screw.

Q-3. Write requirement of clamps, also explain types of clamps.

Q-4. What do you understand by measuring? And how can you differentiate between direct measuring & indirect measuring?



School of Automotive Skills
Session: 2020-21 (Summer Semester)
B. Voc. Program, 1st Semester,
End-Sem. Examination

Set B

Course Code: AUT1106

Answer - key - set B

Time: 2 Hour

Course Name: Automotive Tools & Measurement

Max. Marks: 50

Instruction:

1. Answer all questions from section A, each question carries one mark.
2. Answer all questions from section B, each question carries four mark.
3. Answer all questions from section C, each question carries six mark.

Section – A

10X01 = 10 Marks

Q-1. The least count defines the.....

- | | |
|--|--------------------|
| a. Smallest unit we can measure | c. Smallest length |
| b. Smallest dimension | d. None of these |

Q-2. Which type of measurement does not provide numerical values?

- | | |
|-------------------|----------------------|
| a. Gauging | c. Both (A) & (B) |
| b. Measuring | d. None of the above |

Q-3. In engineering drawing second & fourth angle projections are not used because of:

- | | |
|-----------------------|----------------------|
| a. Overlapping | c. Lacking |
| b. Complications | d. None of the above |

Q-4. Which one of the following ratios represents the reducing scale?

- | | |
|---------------|---------|
| a. 1:1 | c. 2:1 |
| b. 1:2 | d. 10:2 |

Q-5. Which value can be the reading of an instrument having least count = 20µm ?

- | | |
|-----------|-----------------|
| a. 20.05 | c. 20.06 |
| b. 20.062 | d. 20.006 |

Q-6. In first angle projection object is kept between observer & plane of projection:

- a. **True.**
- b. False.
- c. None of the above.



Q-7. Tolerance can be defined as:

- a. **Permissible variation of specified dimension.**
- b. Bi-Lateral dimension.
- c. Unilateral dimension.
- d. Both (a) &(c).

Q-8. A view is obtained making an imaginary cut through the part.

- a. Front View.
- b. Side View.
- c. **Sectional View.**
- d. Top View.

Q-9. When the tolerance distribution is only on one side of the basic size, it is known as:

- a. **Unilateral tolerance.**
- b. Bilateral tolerance.
- c. None of the above.

Q-10. Which value can be the reading of an instrument having least count = $50\mu\text{m}$?

- a. **19.05**
- b. 18.062
- c. 19.06
- d. 18.006

Section – B

04X04 = 16 Marks

Q-1. Describe types of nuts.

Ans:

Nuts of different types are used depending on the requirement of the assembly.

There are different types of nut:

Hexagonal nuts

Square nuts

Self locking nuts

T- nuts

Slotted & Castle nuts

Round nuts

Slotted Round nuts

1. This is the most commonly used nut in structures and machine tool construction

Hexagonal nuts are available in different thicknesses, thin nuts are used as lock nuts

2. Square nuts are provided with square bolts and are most commonly used in coaches

3. Also known as Simmonds lock nut.

This nut has an internal groove cut in which a fiber or nylon ring is inserted

This ring holds the nut tightly on the bolt and serves as a locking device

Self locking nuts are not used with studs.

Q-2. Write a short note on spanners.

Ans:

Spanners are used for operating:

- Threaded Fasteners
- Bolts
- Nuts
- Spanners are made with jaws or opening that fit square or hexagonal nuts and bolts and screw heads.
- They are made of High Tensile or alloy steel
- They are drop forged and heat treated for strength
- They are given a smooth surface finish for easy gripping

The basic types of spanners are:

- Open end spanners
- Tube or tubular box spanners
- Socket Spanners
- Ring Spanners
- The correct spanner to use is the one that fits exactly and allows room for use
- They should also permit the job to be done in shorter time

Q-3. What is hammer? Also write name of the components.

Ans:

HAMMERS: -

- An engineer's hammer is a hand tool used for striking purposes while:
 - Punching
 - Bending
 - Chipping
 - Forging
 - Riveting

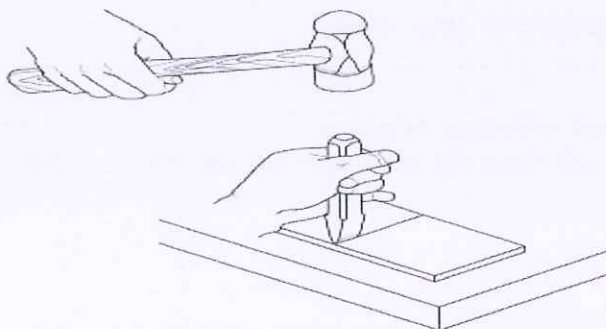

MAJOR PARTS OF HAMMER: -

- The major parts of hammer are hammer head and a handle
- The head is made of drop forged carbon steel, while wooden handle must be capable of absorbing shocks
- The parts of hammer head are:
 - Face
 - Peen
 - Cheek
 - Eyehole

- Wedge

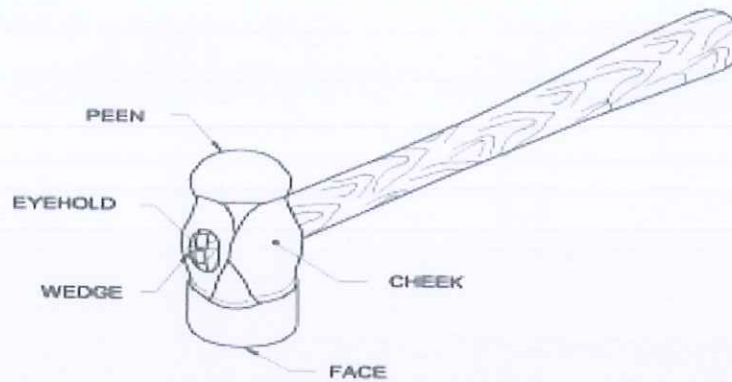

Q-4. Write at least 4 differences between tools and equipment's.

Ans:

Tools that are used in particular fields or activities may have different designations such as "instrument", "utensil", "implement", "machine", "device," or "apparatus". The set of **tools** needed to achieve a goal is "**equipment**". The knowledge of constructing, obtaining and using **tools** is technology.

Section – C

04X06 = 24 Marks

Q-1. Explain pliers and snips.

Ans:

Pliers have a pair of legs joined by a pivot, hinge or fulcrum pin (combination pliers)

Each leg consists of long handle and a short jaw

Elements of pliers:

Flat Jaw: Serrated for general gripping

Pipe Grip: serrated for gripping cylindrical objects

Side Cutters: for cutting off soft wires

Joint Cutters: two joint cutters for cutting or shearing off steel wires

Handles: for applying pressure by hand

Available in sizes from 150 mm to 230 mm (Size = Overall length)

2. Flat Nose Pliers has tapered jaws with flat gripping surfaces which may be either smooth or serrated

It is used for bending and folding narrow strips of thin jobs.

3. This type of pliers is made with tapered round shape

They are used to shape loops in wires and form curves in light metal strips

4. These pliers are available in different ranges of positions with different shapes of pivot pins so that they have various range of jaw opening

Mainly used for gripping

5. They are used for shearing off wires in confined spaces and cutting of wires close to surface level

They are also used for spreading the cotter pin

6. A snip also called a hand shear is used like a pair of scissors to cut thin, soft metal sheets.

Snips are used to cut sheet metal up-to 1.2 mm thickness.

There are several types of snips available for making straight or circular cuts.

The most common snips are straight snips and curved/bent snips.

The choice of snips depends on the shape and type of cut required

Snips are specified by overall length and shape of the blade

7. These are used for making straight cuts and large external curves

Straight snips have thin blades which are strongly on vertical planes

They are therefore only suitable for straight cuts and external curves when surplus waste has to be removed

While cutting the blade of the snips should not cover the marking

Q-2. What is screw? Explain different types of screw.

Ans:

Machine screws are used when a nut cannot be used in the assembly and the component in the assembly has a threaded hole to receive the screws

Types of machine screws:

1. Hexagon head screws
2. Hexagon socket head caps screws
3. Square head and counter sink head screws
4. Set screws
5. Grub screws

1. Hexagon head screws are used when the projection of the screw head will not be an obstruction in the assembly

They are made of steel and for electrical work they are made of brass

2. These are used when the projection of the screw head above the surface is to be avoided

The Indian standard specification head socket cap screws cover the range from 1.6 mm to 36 mm

They are made of steel.

3. There are four types of counter-sink head screws in common use:

Slotted countersink head screws (M1-M20)

Cross recessed countersink head screws (M1.6-M10)

Slotted raised countersink head screws (M1-M20)

Cross recessed, raised countersink head screws (M1.6-M10)

Countersink screws are capable of aligning the matching component correctly with threaded hole

4. Square head screws are used in places where there is frequent removal and refitting of the assembly

These screws are tightened to a higher torque using a wrench

Square head screws are also available with a collar

There is a washer at the base which is integral part of the head

The purpose of collar is to protect the work surface from damages due to constant use of wrenches

Q-3. Write requirement of clamps, also explain types of clamps.

Ans:

Clamps are used for preventing the movement of work and for holding the job tight

Requirements of clamping devices

Should be able to manipulate for easy loading

Should provide the required clamping force

Should be capable of locking with minimum movement

Should accommodate a range of sizes of jobs

A typical clamping device employs a screw and nut

to provide the clamping force

1. C- CLAMPS:

These clamps are in the shape of C

The C clamp has its body forged or cast

One end of clamp is machined flat

The other end is drilled and threaded to accommodate a screw rod which is operated by a handle

The screw rod carries a swivel pad which is free to revolve

The clamp is hardened and face is serrated

Used for:

On an angle plate

Drill press table

Two or more work piece together

2. TOOL MAKER'S CLAMPS: Most commonly used by tool makers for holding small machined flat pieces

Two rectangular pieces of steel perfectly machined and inner faces coming in contact with job perfectly parallel

They are assembled by means of two threaded rods

Screw rod A –to adjust gap between two holding faces

Screw rod B- tightened to maintain required pressure (hole in head for passing cylindrical pin for tightening purpose)

Used for holding previously machined work which is flat and parallel

Also known as parallel clamp

Q-4. What do you understand by measuring? And how can you differentiate between direct measuring & indirect measuring?

Ans:

Measuring is a process by means of which a measured value is determined by comparing a given size with a statutory unit of measure.

Direct measuring: In this, the object to be measure is compared directly with the known dimension.

In-direct measuring: In this, the dimension is transferred from the measuring tool to the workpiece with the assistance of intermediate equipment

