



School of Automotive Skills
Session: 2021-22 (Summer Semester)
B. Voc. Program, 3rd Semester,
End-Sem. Examination

Course Code: AUT1301

Time: 2 Hours

Course Name: Automotive Power Train

Max. Marks: 50

Instruction:

1. Answer all questions from section A, each question carries one mark.
2. Answer all questions from section B, each question carries four mark.
3. Answer all questions from section C, each question carries six mark.

Section – A

10X01 = 10 Marks

Q.1 If one or more nozzles are not spraying correctly then _____ occurs:

- | | |
|----------------|--------------------------|
| a. Dripping | c. Misfiring |
| b. Cold firing | d. None of the mentioned |

Q. 2 Fuel is injected into the cylinder at the end of _____ stroke:

- a. Suction
- b. Compression
- c. Expansion
- d. Exhaust

Q.3 Which of the following is one of the major exhaust emissions from CI engines compared to SI engines?

- | | |
|---------------------------|------------------------|
| a. Oxides of nitrogen | c. Particulates |
| b. CO and CO ₂ | d. Unburnt hydrocarbon |

Q.4 Which is the most commonly use antifreeze ?

- | | |
|-----------------|--------------------|
| a. Ethyl octane | c. Alcohol |
| b. Water | d. Ethylene glycol |

Q.5 In which condition of the vehicle does NO_x emission in SI engine will be lowest?

- | | |
|-------------|-----------------|
| a. Cruising | c. Accelerating |
| b. Idling | d. Decelerating |

Q.6 The transferring of heat from engine to coolant is happened through which heat transfer mode?

- | | |
|---------------|----------------------|
| a. Convection | c. Radiation |
| b. Conduction | d. None of the above |

Q.7 A Rotating force is called _____.

- | | |
|---------------|-----------------------|
| a. Horsepower | d. Eccentric movement |
| b. Torque | |



BHARTIYA SKILL DEVELOPMENT UNIVERSITY

Q.8 The coolant flow through the radiator is controlled by the _____.

- a. Size of the passages in the block
- b. Thermostat
- c. Cooling fan(s)
- d. Water pump

Q.9 The normal operating temperature (coolant temperature) of an engine equipped with a 195°F thermostat is _____.

- a. 175°F to 195°F
- b. 185°F to 205°F
- c. 195°F to 215°F
- d. 175°F to 215°F

Q.10 Normal oil pump pressure in an engine is _____ PSI.

- a. 3 to 7
- b. 100 to 150
- c. 10 to 60
- d. 180 to 210

Section – B

04X04 = 16 Marks

Q.11 What Is Compression Ration? Explain if compression is Lower and higher.

Q. 12 Why is a cooling system pressurized?

Q. 13 What are 10 common causes of overheating?

Q. 14 Write short note on

- a. Engine gasket
- b. Piston rings

Section – C

04X06 = 24 Marks

Q. 15 Explain Types of Engine Oil Pump.

Q. 16 Explain fuel supply system for diesel engine with the help of a diagram.

Q. 17 Explain the flow of coolant through the engine and radiator.

Q. 18 Describe how to perform a drain, flush, and refill procedure on a cooling system.

Vijay



School of Automotive Skills
Session: 2021-22 (Summer Semester)
B. Voc. Program, 3rd Semester,
End-Sem. Examination

Course Code: AUT1301

Time: 2 Hours

Course Name: Automotive Power Train

Max. Marks: 50

Instruction:

1. Answer all questions from section A, each question carries one mark.
2. Answer all questions from section B, each question carries four marks.
3. Answer all questions from section C, each question carries six marks.

Section – A

10X01 = 10 Marks

Q.1 If one or more nozzles are not spraying correctly then _____ occurs:

- | | |
|----------------|--------------------------|
| a. Dripping | c. Misfiring |
| b. Cold firing | d. None of the mentioned |

Q.2 Fuel is injected into the cylinder at the end of _____ stroke:

- | | |
|-----------------------|--------------|
| a. Suction | c. Expansion |
| b. Compression | d. Exhaust |

Q.3 Which of the following is one of the major exhaust emissions from CI engines compared to SI engines?

- | | |
|---------------------------|------------------------|
| a. Oxides of nitrogen | c. Particulates |
| b. CO and CO ₂ | d. Unburnt hydrocarbon |

Q.4 Which is the most commonly use antifreeze ?

- | | |
|-----------------|---------------------------|
| a. Ethyl octane | c. Alcohol |
| b. Water | d. Ethylene glycol |

Q.5 In which condition of the vehicle does NO_x emission in SI engine will be lowest?

- | | |
|------------------|-----------------|
| a. Cruising | c. Accelerating |
| b. Idling | d. Decelerating |

Q.6 The transferring of heat from engine to coolant is happened through which heat transfer mode?

- | | |
|----------------------|----------------------|
| a. Convection | c. Radiation |
| b. Conduction | d. None of the above |

Q.7 A Rotating force is called _____.

- | | |
|------------------|-----------------------|
| a. Horsepower | d. Eccentric movement |
| b. Torque | |



BHARTIYA SKILL DEVELOPMENT UNIVERSITY

Q.8 The coolant flow through the radiator is controlled by the _____.

- a. Size of the passages in the block
- b. Thermostat**
- c. Cooling fan(s)
- d. Water pump

Q.9 The normal operating temperature (coolant temperature) of an engine equipped with a 195°F thermostat is _____.

- a. 175°F to 195°F
- b. 185°F to 205°F
- c. 195°F to 215°F**
- d. 175°F to 215°F

Q.10 Normal oil pump pressure in an engine is _____ PSI.

- a. 3 to 7
- b. 100 to 150
- c. 10 to 60**
- d. 180 to 210

Section – B

04X04 = 16 Marks

Q.11 What Is Compression Ratio? Explain if compression is Lower and higher.

Ans

Compression ratio (CR) is the ratio of the difference in the cylinder volume when the piston is at the bottom of the stroke to the volume in the cylinder above the piston when the piston is at the top of the stroke. The compression ratio of an engine is an important consideration when rebuilding or repairing an engine.

If Compression Is Lower	If Compression Is Higher
Lower power	Higher power possible
Poorer fuel economy	Better fuel economy possible
Easier engine cranking	Harder to crank engine, especially when hot
More advanced ignition timing possible without spark knock (detonation)	Less ignition timing required to prevent spark knock (detonation)

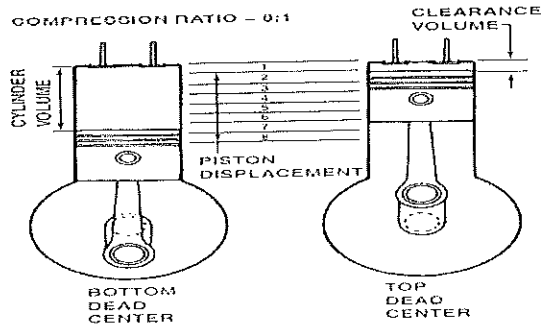

FIGURE 18-18 Compression ratio is the ratio of the volume of the cylinder before compression to the volume of the cylinder after compression. The ratio of the compression ratio is 8:1, which means the gas has an 8:1 compression ratio.

- Q. 12 Why is a cooling system pressurized?
- Q. 13 What are 10 common causes of overheating?
- Q. 14 Write short note on
 - a. Engine gasket
 - b. Piston rings

Section – C

04X06 = 24 Marks

- Q. 15 Explain Types of Engine Oil Pump.

Ans: All oil pumps are called positive displacement pumps, and each rotation of the pump delivers the same volume of oil; therefore, everything that enters must exit. Also a positive displacement pump will deliver more oil and higher pressure as the speed of the pump increases. Most automotive engines use one of two types of oil pumps, either gear or rotor

1. External gear type. A gear-type oil pump is usually driven by a shaft from the distributor, which is driven by the camshaft. As a result, this type of pump rotates at half engine (crankshaft) speed. The gear-type oil pump consists of two spur gears in a close-fit housing—one gear is driven while the other idles. As the gear teeth come out of mesh, they tend to leave a space, which is filled by oil drawn through the pump inlet. When the pump is pumping, oil is carried around the outside of each gear in the space between the gear teeth and the housing. As the teeth mesh in the center, oil is forced from the teeth into an oil passage, thus producing oil pressure.

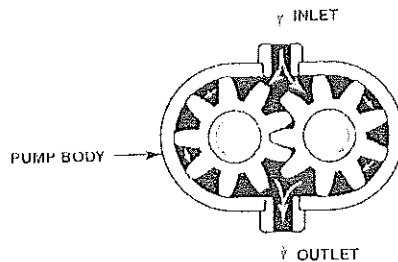

FIGURE 23-6 In an external gear-type of pump, the oil flows through the pump around the outside of each gear. This is an example of a positive displacement pump, where everything entering the pump must leave the pump.



BHARTIYA SKILL DEVELOPMENT UNIVERSITY

2. Internal/external gear type. This type of oil pump is driven by the crankshaft and operates at engine speed. In this style of oil pump, two gears and a crescent stationary element are used.

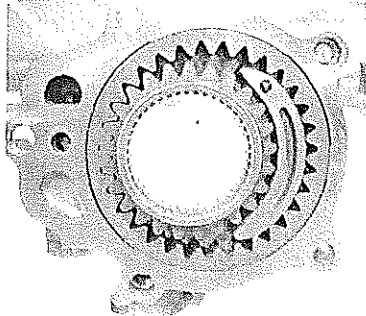
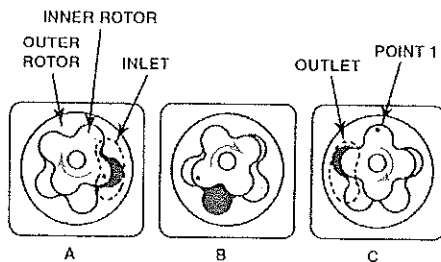

FIGURE 23-7 A type of internal/external gear pump installed in the fuel pump of the engine shown in Figure 23-6.

3. Rotor type. This rotor-type oil pump is driven by the crankshaft and uses a special lobe-shaped gear meshing with the inside of a lobed rotor. The center lobed section is driven and the outer section idles. As the lobes separate, oil is drawn in just as it is drawn into gear-type pumps. As the pump rotates, it carries oil around and between the lobes. As the lobes mesh, they force the oil out from between them under pressure in the same manner as the gear-type pump. The pump is sized so that it will maintain a pressure of at least 10 PSI (70 kPa) in the oil gallery when the engine is hot and idling. Pressure will increase because the engine-driven pump also rotates faster



A. OIL IS PICKED UP IN LOBE OF OUTER ROTOR.
B. OIL IS MOVED IN LOBE OF OUTER ROTOR TO OUTLET.
C. OIL IS FORCED OUT OF OUTLET BECAUSE THE INNER AND OUTER ROTORS MESH TOO TIGHTLY AT POINT 1 AND THE OIL CANNOT PASS THROUGH.

FIGURE 23-8 The operation of a rotor-type oil pump.

4. Gerotor type. This type of positive displacement oil pump uses an inner and an outer rotor. The term is derived from two words: "generated rotor," or gerotor. The inner rotor has one fewer teeth than the outer rotor and both rotate.

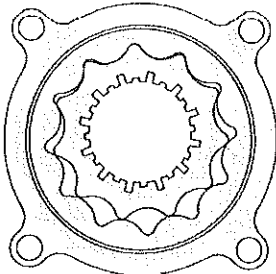

Q. 16 Explain fuel supply system for diesel engine with the help of a diagram.

Ans.

DIESEL FUEL SYSTEM BASICS

INTRODUCTION



BHARTIYA SKILL DEVELOPMENT UNIVERSITY

The function of the diesel fuel system is to inject a precise amount of atomized and pressurized fuel into each engine cylinder at the proper time. Combustion in a diesel engine occurs when this rush of fuel is mixed with hot compressed air. (No electrical spark is used as in a gasoline engine.)

The fuel system consists of the following components.

FUEL TANKS

There are many different types and shapes of fuel tanks. Each size and shape is designed for a specific purpose. The fuel tank must be capable of storing enough fuel to operate the engine for a reasonable length of time. The tank must be closed to prevent contamination by foreign objects. It must also be vented to allow air to enter, replacing any fuel demanded by the engine. Three other tank openings are required--one to fill, one to discharge, and one to drain.

FUEL LINES

There are three types of diesel fuel lines. These include heavyweight lines for the high pressures found between the injection pump and the injectors, medium weight lines for the light or medium fuel pressures found between the fuel tank and injection pump, and lightweight lines where there is little or no pressure.

FUEL FILTERS

Diesel fuel must be filtered not once, but several times in most systems. A typical system might have three stages of progressive filters--a filter screen at the tank or transfer pump, a primary fuel filter, and a secondary fuel filter. In series filters, all the fuel goes through one filter and then through the other. In parallel filters, part of the fuel goes through each filter.

For more information on fuel filters, see [Diesel Fuel Filter Basics](#).

FUEL TRANSFER PUMPS

Simple fuel systems use gravity or air pressure to get fuel from the tank to the injection pump. On modern high speed diesel engines, a fuel transfer pump is normally used. This pump, driven by the engine, supplies fuel automatically to the diesel injection system. The pump often has a hand primer lever for bleeding air from the system. Modern injection pumps are almost all jerk pumps which use the plunger and cam method of fuel injection.

FUEL INJECTION SYSTEMS

There are four primary systems for injecting fuel:

1. Individual pump and injector for each cylinder
2. Combined pump and injector for each cylinder (*unit injector type*)
3. One pump serving injectors for several cylinders (*distributor type*)
4. Pumps in a common housing with injectors for each cylinder (*common rail system*)

The common rail system is rapidly gaining popularity for on-road applications. The in-line and distributor types are used on off-road vehicles and industrial machines.



BHARTIYA SKILL DEVELOPMENT UNIVERSITY

High Pressure Common Rail Fuel System Diagram

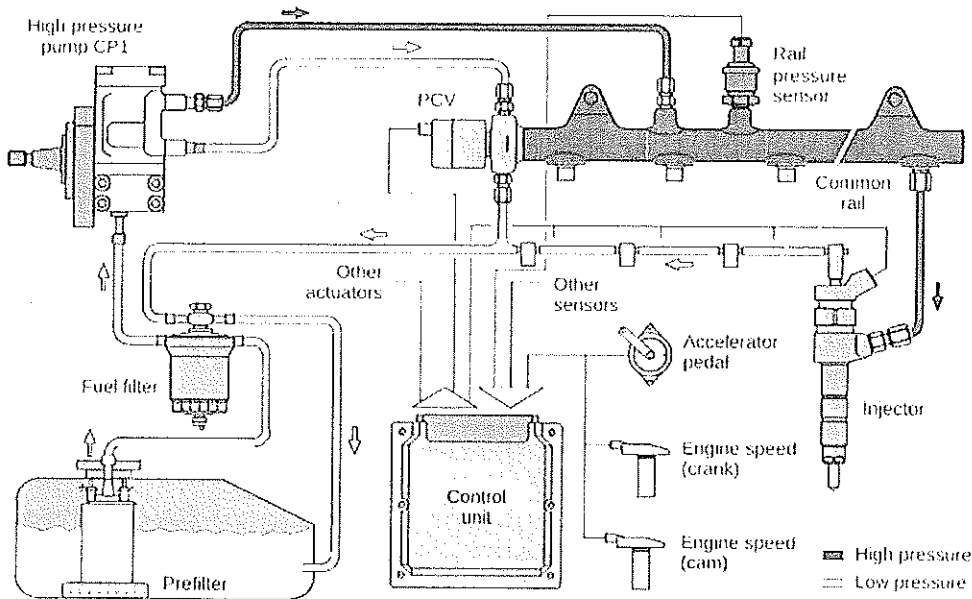

FUEL INJECTORS

Diesel fuel injectors are arguably the most important fuel system component. The job of the injectors is to deliver a precise amount of atomized and pressurized fuel into each cylinder. Highly atomized, pressurized fuel distributed evenly throughout the cylinder results in increased power and fuel economy, decreased engine noise, and smoother operation.

Modern diesel fuel injectors, such as those found in common rail fuel systems, use piezoelectricity. Piezoelectric injectors are extremely precise and can handle the very high pressures found in common rail applications.

DIESEL FUEL

The fuel used in modern high speed diesel engines is derived from the heavier residues of crude oil that are left over after the more volatile fuels such as gasoline are removed during the refining process. The most common grade of diesel fuel is 2-D, more commonly known as ultra low sulfur diesel (ULSD).

For more information on diesel fuel, see [Ultra Low Sulfur Diesel Basics](#).

WATER

A common enemy of diesel fuel systems is water. Unfortunately, water is more common in diesel fuel than most people realize. Should water find its way into an injection system, it will rapidly oxidize ferrous metal (steel) components. Some of the most common failures attributed to water include:

- Injection component seizure
- Sticky metering components in both the pump and injector
- Governor/metering component failure

CONCLUSION

A diesel fuel system is a critical component of any diesel engine and its optimum operation is essential for peak performance. E-ZOIL manufactures several additives formulated to address common issues encountered by the diesel fuel system. DIESEL AID, DIESEL AID + CETANE, ARTIC POWER, ARTIC FLO and CLEAN & LUBE increase fuel system lubricity preventing premature failure of fuel pumps and injectors. Additionally, DIESEL AID and



BHARTIYA SKILL DEVELOPMENT UNIVERSITY

DIESEL AID + CETANE totally disperse water, which also causes premature failure of fuel system components.

Q. 17 Explain the flow of coolant through the engine and radiator.

Q. 18 Describe how to perform a drain, flush, and refill procedure on a cooling system.

Vijay



School of Automotive Skills
Session: 2021-22 (Summer Semester)
B. Voc. Program, 3rd Semester,
End-Sem. Examination

Course Code: AUT1301

Time: 2 Hours

Course Name: Automotive Power Train

Max. Marks: 50

Instruction:

1. Answer all questions from section A, each question carries one mark.
2. Answer all questions from section B, each question carries four mark.
3. Answer all questions from section C, each question carries six mark.

Section – A

10X01 = 10 Marks

- Q.1 Air filters can remove particles and dirt as small as _____.
- a. 5 to 10 microns
 - b. 10 to 25 microns
 - c. 30 to 40 microns
 - d. 40 to 50 micron
- Q. 2 Why are the EGR gases cooled before entering the engine on some engines?
- a. Cool exhaust gas is more effective at controlling NOx emissions
 - b. To help prevent the exhaust from slowing down
 - c. To prevent damage to the intake valve
 - d. To prevent heating the air-fuel mixture in the cylinder
- Q. 3 What is the purpose of an intercooler?
- a. To reduce the temperature of the air entering the engine
 - b. To cool the turbocharger
 - c. To cool the engine oil on a turbocharged engine
 - d. To cool the exhaust before it enters the turbocharger
- Q. 4 How are most turbochargers lubricated?
- a. By engine oil under pressure through lines from the engine
 - b. By an internal oil reservoir
 - c. By greased bearings
 - d. No lubrication is needed.
- Q.5 In which condition of the vehicle does NOx emission in SI engine will be lowest?
- a. Cruising
 - b. Idling
 - c. Accelerating
 - d. Decelerating



BHARTIYA SKILL DEVELOPMENT UNIVERSITY

Q.6 The transferring of heat from engine to coolant is happened through which heat transfer mode?

- a. Convection
- b. Conduction
- c. Radiation
- d. None of the above

Q.7 A Rotating force is called _____.

- a. Horsepower
- b. Torque
- c. Combustion pressure
- d. Eccentric movement

Q. 8 The coolant flow through the radiator is controlled by the _____.

- a. Size of the passages in the block
- b. Thermostat
- c. Cooling fan(s)
- d. Water pump

Q.9 The normal operating temperature (coolant temperature) of an engine equipped with a 195°F thermostat is _____.

- a. 175°F to 195°F
- b. 185°F to 205°F
- c. 195°F to 215°F
- d. 175°F to 215°F

Q.10 Normal oil pump pressure in an engine is _____ PSI.

- a. 3 to 7
- b. 100 to 150
- c. 10 to 60
- d. 180 to 210

Section – B

04X04 = 16 Marks

Q. 11 What are the advantages and disadvantages of turbocharging?

Q. 12 Why is a 50/50 mixture of antifreeze and water commonly used as a coolant?

Q. 13 Brief What is normal operating coolant temperature?

Q. 14 Write short notes on engine head gasket.

Section – C

04X06 = 24 Marks

Q. 15 How does a muffler quiet exhaust noise?

Q. 16 Describe the Engine compression test.

Q. 17 What is camshaft.? Explain types of camshaft in engine.

Q. 18 What is cylinder head? Explain different types of cylinder heads.

Vipin



School of Automotive Skills
Session: 2021-22 (Summer Semester)
B. Voc. Program, 3rd Semester,
End-Sem. Examination

Course Code: AUT1301

Time: 2 Hours

Course Name: Automotive Power Train

Max. Marks: 50

Instruction:

1. Answer all questions from section A, each question carries one mark.
2. Answer all questions from section B, each question carries four mark.
3. Answer all questions from section C, each question carries six mark.

Section – A

10X01 = 10 Marks

Q.1 Air filters can remove particles and dirt as small as _____.

- a. 5 to 10 microns
- b. 10 to 25 microns
- c. 30 to 40 microns
- d. 40 to 50 microns

Q. 2 Why are the EGR gases cooled before entering the engine on some engines?

- a. Cool exhaust gas is more effective at controlling NOx emissions
- b. To help prevent the exhaust from slowing down
- c. To prevent damage to the intake valve
- d. To prevent heating the air-fuel mixture in the cylinder

Q. 3 What is the purpose of an intercooler?

- a. To reduce the temperature of the air entering the engine
- b. To cool the turbocharger
- c. To cool the engine oil on a turbocharged engine
- d. To cool the exhaust before it enters the turbocharger

Q. 4 How are most turbochargers lubricated?

- a. By engine oil under pressure through lines from the engine
- b. By an internal oil reservoir
- c. By greased bearings
- d. No lubrication is needed.

Q.5 In which condition of the vehicle does NOx emission in SI engine will be lowest?

- a. Cruising
- b. Idling
- c. Accelerating
- d. Decelerating



BHARTIYA SKILL DEVELOPMENT UNIVERSITY

Q.6 The transferring of heat from engine to coolant is happened through which heat transfer mode?

- a. Convection
- b. Conduction**
- c. Radiation
- d. None of the above

Q.7 A Rotating force is called _____.

- a. Horsepower
- b. Torque**
- c. Combustion pressure
- d. Eccentric movement



Q. 8 The coolant flow through the radiator is controlled by the _____.

- a. Size of the passages in the block
- b. Thermostat**
- c. Cooling fan(s)
- d. Water pump

Q.9 The normal operating temperature (coolant temperature) of an engine equipped with a 195°F thermostat is _____.

- a. 175°F to 195°F
- c. 195°F to 215°F**
- b. 185°F to 205°F
- d. 175°F to 215°F

Q.10 Normal oil pump pressure in an engine is _____ PSI.

- a. 3 to 7
- c. 10 to 60**
- b. 100 to 150
- d. 180 to 210

Section – B

04X04 = 16 Marks

Q. 11 What are the advantages and disadvantages of turbocharging?

Q.12 Why is a 50/50 mixture of antifreeze and water commonly used as a coolant?

Ans: According to the freezing point, it appears that the lowest freezing point of coolant is achieved when 70% antifreeze is used with 30% water. While the freezing temperature is lower, the high concentrate of antifreeze reduces the heat transferability of the coolant. Therefore, most vehicle manufacturers specify a 50/50 mixture of antifreeze and water to achieve the best balance between freeze protection and heat conductivity.

Q. 13 Brief What is normal operating coolant temperature?

Q. 14 Write short notes on engine head gasket.

Ans: The contact surface of the cylinder block and cylinder head must be sealed gastight by the cylinder head gasket.

It is subjected to the following loads:

- Chemical loads: Aggressive fuel components and hot combustion gases in the cylinders.
- Thermal loads: High combustion temperatures and inducted cold fresh gas.
- Mechanical loads: Rapid changing overpressure during the compression, combustion and vacuum during induction(Suction).

The cylinder head gasket must satisfy the following requirements:

- Elastic adaption of the sealing surfaces in all operating states/conditions.
- Low tendency to settle to facilitate cylinder head tensioning without retightening.



BHARTIYA SKILL DEVELOPMENT UNIVERSITY

- **Material used for Gasket:**

1. **Metal/ Soft material cylinder head gasket:** A metallic carrier plate roughly 0.3 mm thick is provided with clamping teeth. These teeth hold the soft material layer applied on both sides. The soft material is provided with a pore-filling plastic coating to improve its resistance to the surrounding media. The combustion chamber passages are beaded in. e.g.: With an aluminum plated steel plate. The sealing effect at the liquid passages can be further improved by an elastomer coating.

2. **Metal cylinder head gasket:** This is usually manufactured as multilayer cylinder head gasket from steel plates. For the purpose of providing a secure gas seal, beads or plate linings are required to increase the local pressing. The sealing effect at the liquid passages is also increased by elastomer coatings

Section – C

04X06 = 24 Marks

Q. 15 How does a muffler quiet exhaust noise?

Q. 16 Describe the Engine compression test.

Ans:

An engine compression test is one of the fundamental engine diagnostic tests that can be performed. For smooth engine operation, all cylinders must have equal compression. An engine can lose compression by leakage of air through one or more of only three routes. _____ Intake or exhaust valve _____ Piston rings (or piston, if there is a hole) _____ Cylinder head gasket For best results, the engine should be warmed to normal operating temperature before testing. An accurate compression test should be performed as follows: STEP 1 Remove all spark plugs. This allows the engine to be cranked to an even speed. Be sure to label all spark plug wires.

CAUTION: Disable the ignition system by disconnecting the primary leads from the ignition coil or module or by grounding the coil wire after removing it from the center of the distributor cap. Also disable the fuel-injection system to prevent the squirting of fuel into the cylinder.

STEP 2 Block open the throttle. This permits the maximum amount of air to be drawn into the engine. This step also ensures consistent compression test results. STEP 3 Thread a compression gauge into one spark plug hole and crank the engine.

Continue cranking the engine through four compression strokes. Each compression stroke makes a puffing sound. NOTE: Note the reading on the compression gauge after the first puff. This reading should be at least one-half the final reading. For example, if the final, highest reading is 150 PSI, then the reading after the first puff should be higher than 75 PSI. A low first-puff reading indicates possible weak piston rings. Release the pressure on the gauge and repeat for the other cylinders. STEP 4 Record the highest readings and compare the results. Most vehicle manufacturers specify the minimum compression reading and the maximum allowable variation among cylinders. Most manufacturers specify a maximum difference of 20% between the highest reading and the lowest reading. For example: If the high reading is 150 PSI Subtract 20% 30 PSI Lowest allowable compression is 120 PSI



NOTE: To make the math quick and easy, think of 10% of 150, which is 15 (move the decimal point to the left one place). Now double it: 15 2

30. This represents 20%. NOTE: During cranking, the oil pump cannot maintain normal oil pressure. Extended engine cranking, such as that which occurs during a compression test, can cause hydraulic lifters to collapse. When the engine starts, loud valve clicking noises may be heard. This should be considered normal after performing a compression test, and the noise should stop after the vehicle has been driven a short distance.

Q. 17 What is camshaft.? Explain types of camshaft in engine.

Ans: Cam shaft is used to operate the intake and exhaust valves at right timings.

- The key parts of any camshaft are the lobes. As the camshaft spins, the lobes open and close the intake and exhaust valves in time with the motion of the piston.

Types of camshaft

- Pushrod
- Over Head
- Single overhead cam (SOHC)
- Double overhead cam (DOHC)
- Advancement- Electronic Variable valve timing mechanism installed in Camshaft

Camshaft assembly

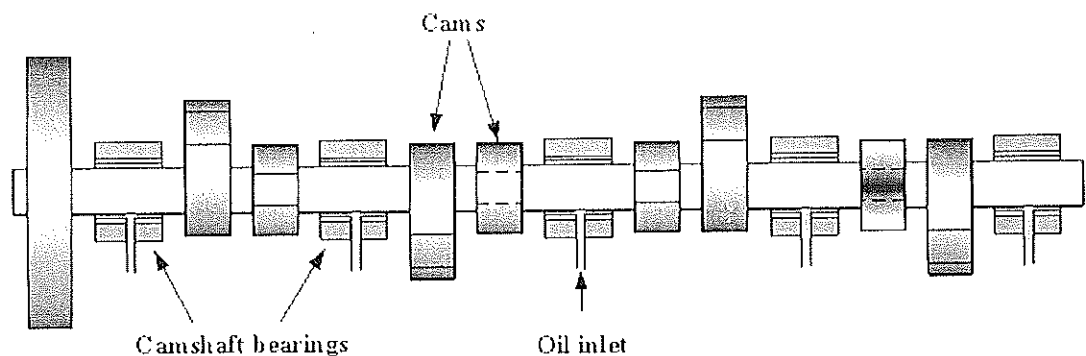

Material which is used to manufacture

- Carbon steel
- Alloyed steels
- Nitride steel

Timing

A steel billet racing camshaft with noticeably broad lobes (very long duration)

The relationship between the rotation of the camshaft and the rotation of the crankshaft is of critical importance. Since the valves control the flow of the air/fuel mixture intake and exhaust gases, they must be opened and closed at the appropriate time during the stroke of the piston. For this reason, the camshaft is connected to the crankshaft either directly, via a gear mechanism, or indirectly via a belt or chain called a timing *belt* or *timing chain*. Direct drive using gears is unusual because of the cost. The frequently reversing torque caused by the slope of the cams tends to cause gear rattle which for an all-metal gear train requires further expense of a cam damper. Rolls-Royce V8 used gear drive as, unlike chain, it could be made silent and to last the life of the engine. Where gears are used in cheaper cars, they



BHARTIYA SKILL DEVELOPMENT UNIVERSITY

tend to be made from resilient fibre rather than metal, except in racing engines that have a high maintenance routine. Fibre gears have a short life span and must be replaced regularly, much like a timing belt. In some designs the camshaft also drives the distributor and the oil and fuel pumps. Some vehicles may have the power steering pump driven by the camshaft. With some early fuel injection systems, cams on the camshaft would operate the fuel injectors. Honda redesigned the VF750 motorcycle from chain drive to the gear drive VFR750 due to insurmountable problems with the VF750 Hi-Vo inverted chain drive.

The timing of the camshaft can be advanced to produce better low RPM torque or retarded for better high RPM power. Changing cam timing moves the overall power produced by the engine down or up the RPM scale. The amount of change is very little (usually < 5 deg) and affects valve to piston clearances.

Q. 18 What is cylinder head? Explain different types of cylinder heads.

Ans: The cylinder head seals off the combustion chamber at the top. It is secured by the cylinder head bolts with the inserted cylinder head gasket on cylinder block.

❖ **Design of Cylinder Head:** The cylinder head contains the fresh gas and exhaust gas ducts with their valves seats and usually also the compression space (clearance volume).

- It accommodates the spark plugs as well as the fuel injectors in the case of direct injection engines together with the engine timing components. E.g. The valves.
- The camshaft is often mounted on the cylinder head. The cylinder head is subjected to high loads resulting from combustion pressure and hot combustion gases and must therefore demonstrate high inherent stability, good heat conduction and low thermal expansion.

• There are two types of cylinder head: -

1. **Liquid-cooled cylinder head:** This is predominantly cast from Al alloys for each cylinder individually or for the entire block in one piece. The coolant flows from the cylinder block into the cylinder head via flow ducts.

2. **Air-Cooled Cylinder Head:** This is manufactured entirely from AL alloys and is provided with cooling fins. Because the transfer of heat to air is less efficient than to coolant (cooling liquid), the cooling surface must be enlarged by cooling fins.

Note: - Compression Space: The compression space is the smallest combustion chamber. It is sealed towards the bottom by the position of the piston at TDC, where part of the compression space may be situated in the piston crown.

Geometrical shape:

- The geometrical shape of the compression space has a significant bearing on:-
- Surface to volume ratio
- Position of the spark plug and fuel injector
- Mixture Swirl
- Combustion Sequence
- Knock resistance



BHARTIYA SKILL DEVELOPMENT UNIVERSITY

- Achievable Compression ratio
- Valve arrangement.
- Note: The compression space influences engine efficiency and thus performance, torque and fuel consumption as well as emissions characteristics.

Vijay



Registration No.:

BHARTIYA SKILL DEVELOPMENT UNIVERSITY

School of Automotive Skills
Session: 2021-22 (Summer Semester)
B. Voc. Program, 3rd Semester,
End Sem. Examination

Course Code: AUT 1302

Time: 2 Hour

Course Name: Automotive Breaking, Suspension

Max. Marks: 50

and Steering System

Instruction:

1. All the questions are compulsory to attend.
2. Students are not allowed to bring any smart device or cell phone in the exam hall.
3. Marks will be deducted if any overwriting in words will be found.

Section – A

10X01 = 10 Marks

1. Which of the following steering system works on turning mechanism?
 - a) Ackermann
 - b) a & b
 - c) Davis
 - d) None of the above
2. Which one of the following option is used in ABS for working?
 - a) Leaf spring
 - b) Brake pump
 - c) Vehicle speed sensor
 - d) All of the mentioned
3. What is the full form of ESP system?
 - a) Electronic Stability Program
 - b) Engine Stability Program
 - c) Electronic Steering Program
 - d) None of above



BHARTIYA SKILL DEVELOPMENT UNIVERSITY

4. Which one of these is not the part of hydraulic steering system?
 - a) Hydraulic Pump
 - b) Electric Motor
 - c) Steering wheel
 - d) Rack and pinion
5. What is wishbone system?
 - a) Steering system
 - b) Suspension system
 - c) Braking system
 - d) None of these
6. Which parts of an automobile is first suspension for the vehicle?
 - a) Leaves of leaf spring
 - b) Coil Spring
 - c) Tires
 - d) None of the above
7. The type of axle which is not being used to transmit power is.....
 - a) Dead axle
 - b) Live axle
 - c) both (a) & (b)
 - d) None of the above
8. Which type of suspension system is used in the Honda City?
 - a) Macpherson strut system
 - b) Wish Bone system
 - c) Rigid suspension system
 - d) None of the above
9. If a person turns the steering wheel 450 degrees then how much should the wheel turns while having a steering ratio of 40:4?
 - a) 11 degrees
 - b) 120 degrees
 - c) 45 degrees
 - d) None of the above
10. Which material is used to manufacture brake disc in braking system?
 - a) Wood
 - b) Spring Steel
 - c) Cast iron
 - d) High Carbon Steel

Section – B

04X04 = 16 Marks

11. Explain the process of hydraulic braking system.
12. What are the purposes of rigid suspension system?
13. Write the components of hydraulic electrical steering system.
14. Suppose a vehicle is having a problem of "Noise while braking", write the process of diagnose and repair according to you.



BHARTIYA SKILL DEVELOPMENT UNIVERSITY

Section – C

04X06 = 24 Marks

15. Write down the process of front coil spring replacement of Honda city?
16. What is drive axle? Also, explain all types of rear axle.
17. Write down the process of overhauling of electrical steering system?
18. Write down the major problems which can happen because of uneven trade wear, also explain Tire changing process.

Vijai



Registration No.:

BHARTIYA SKILL DEVELOPMENT UNIVERSITY

School of Automotive Skills
Session: 2021-22 (Summer Semester)
B. Voc. Program, 3rd Semester,
End Sem. Examination

Course Code: AUT 1302

Time: 2 Hour

Course Name: Automotive Breaking, Suspension
and Steering System

Max. Marks: 50

Instruction:

1. All the questions are compulsory to attend.
2. Students are not allowed to bring any smart device or cell phone in the exam hall.
3. Marks will be deducted if any overwriting in words will be found.

Section – A

10X01 = 10 Marks

1. Which of the following steering system works on turning mechanism?
 - a) Ackermann
 - b) a & b
 - c) Davis
 - d) None of the above
2. Which one of the following option is used in ABS for working?
 - a) Leaf spring
 - b) Brake pump
 - c) Vehicle speed sensor
 - d) All of the mentioned
3. What is the full form of ESP system?
 - a) Electronic Stability Program
 - b) Engine Stability Program
 - c) Electronic Steering Program
 - d) None of above

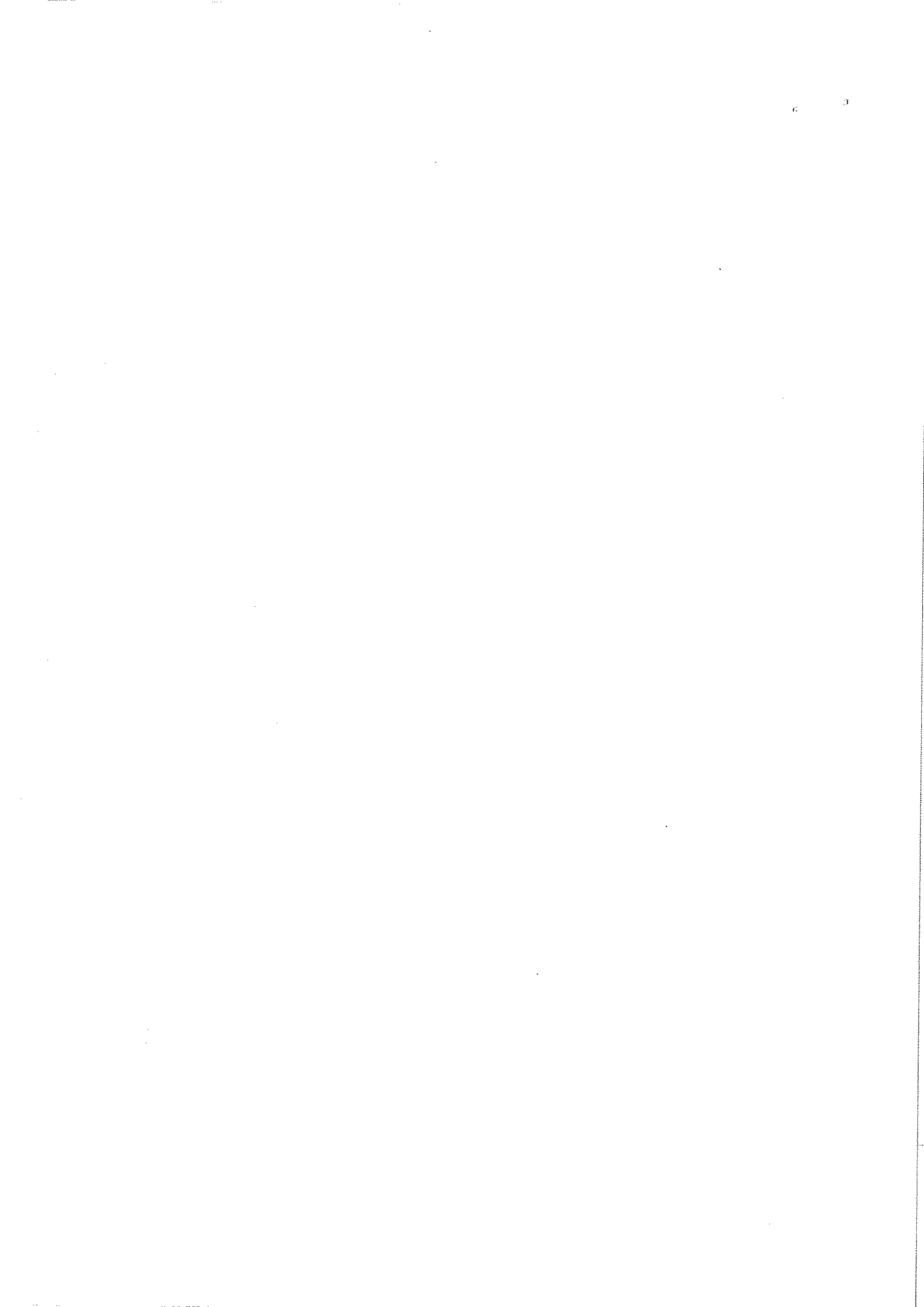



4. Which one of these is not the part of hydraulic steering system?
- a) Hydraulic Pump
b) **Electric Motor**
c) Steering wheel
d) Rack and pinion
5. What is wishbone system?
- a) Steering system
b) **Suspension system**
c) Braking system
d) None of these
6. Which parts of an automobile is first suspension for the vehicle?
- a) Leaves of leaf spring
b) Coil Spring
c) **Tires**
d) None of the above
7. The type of axle which is not being used to transmit power is.....
- a) Dead axle
b) **Live axle**
c) both (a) & (b)
d) None of the above
8. Which type of suspension system is used in the Honda City?
- a) **Macpherson strut system**
b) Wish Bone system
c) Rigid suspension system
d) None of the above
9. If a person turns the steering wheel 450 degrees then how much should the wheel turns while having a steering ratio of 40:4?
- a) 11 degrees
b) 120 degrees
c) **45 degrees**
d) None of the above
10. Which material is used to manufacture brake disc in braking system?
- a) Wood
b) Spring Steel
c) **Cast iron**
d) High Carbon Steel

Section – B

04X04 = 16 Marks

11. Explain the process of hydraulic braking system.

- Ans. **Hydraulic braking system:**
- In addition to the mechanical advantage provided by leverage, all vehicles use hydraulic pressure to help increase brake application force. All braking systems require that a driver's force is transmitted to the drum or rotor attached to each wheel.

BHARTIYA SKILL DEVELOPMENT UNIVERSITY

The force that can be exerted on the brake pedal varies due to the strength and size of the driver. Engineers design braking systems to require less than 150 lb of force (68 kg) from the driver, yet provide the force necessary to stop a heavy vehicle from high speed.

12. What are the purposes of rigid suspension system?

Ans. **Rigid Suspension system:** Rigid Suspension system has both right and left wheel attached to the same solid axle.

When one wheel hits a bump in the road, its upward movement causes a slight tilt of the other wheel.

Example: Used for heavy duty vehicles. Construction is simple. Comfort is not great due to low sprung & high un sprung weight. Used in Truck's Front and rear axle both & in Car's Rear Suspension (Mostly Leaf Spring rear suspension)

13. Write the components of hydraulic electrical steering system.

Ans.

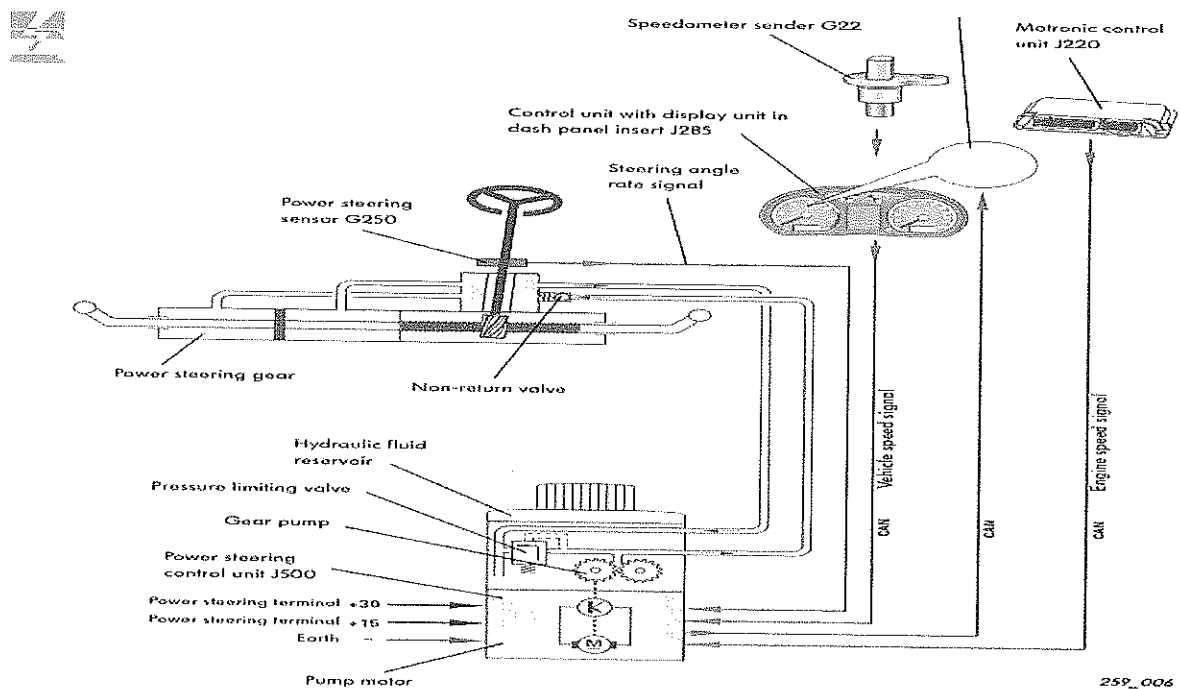

14. Suppose a vehicle is having a problem of "Noise while braking", write the process of diagnose and repair according to you.

Ans. **STEP 1** Verify the customer complaint. For example, common drum brake concerns include:

- Low brake pedal
- Parking brake does not hold the vehicle on a hill

BHARTIYA SKILL DEVELOPMENT UNIVERSITY

- Noise while braking
- Noise when the vehicle is moving, but the brakes are not applied.

STEP 2 Perform a visual inspection of the brakes and related parts, such as the wheels, tires, and suspension system.

STEP 3 Determine the root cause. For example, this could include determining that the parking brake linkage is corroded causing the brake shoes to wear. Replacing just the brake shoes will not correct the root cause.

STEP 4 Restore the brake system to like-new operation, which is the purpose of any repair.

STEP 5 Test-drive the vehicle to verify that the service has corrected the customer's complaint.

Section – C

04X06 = 24 Marks

15. Write down the process of Suspension frame coil replacement of Honda city?

Ans. The following steps are of coil spring replacement:

1. Removal of wheel
2. Remove shock absorber mounting bolts
3. Hold wheel knuckle using rope/cloth.
4. Compression of coil spring.
5. Removal of coil spring
6. Checking of travel of shock absorber
7. Reverse the process for assembly

16. What is drive axle? Explain types of rear axles.

- **DRIVE AXLE SHAFTS:** Unequal-length drive axle shafts (also called half shafts) result in unequal drive axle shaft angles to the front drive wheels. This unequal angle often results in a pull on the steering wheel during acceleration. This pulling to one side during acceleration due to unequal engine torque being applied to the front drive wheels is called torque steer. To help reduce the effect of torque steer, some vehicles are manufactured with an intermediate shaft that results in equal drive axle shaft angles.



BHARTIYA SKILL DEVELOPMENT UNIVERSITY

17. Write down the process of overhauling of electrical steering system?

Ans. The following process is for overhauling of electrical steering system:

1. Removal of steering from vehicle.
2. Removal of steering sensor from body.
3. Removal of steering motor.
4. Removal of steering motor gear.
5. Removal of tie rod from both side.
6. Removal of rack from column.
7. Reversing the process for assembly.

18. Write down the major problems which can happen because of uneven trade wear, also explain Tire changing process.

Ans. Following are problems that can happen because of uneven trade wear:

1. Steering pull.
2. Rapid wear.
3. Suspension worn out.
4. Alignment angle mismatched.
5. Vehicle instability.

Vijay



BHARTIYA SKILL DEVELOPMENT UNIVERSITY

Registration No.:

Q.P. Set B

School of Automotive Skills
Session: 2021-22 (Summer Semester)
B. Voc. Program, 3rd Semester,
End Sem. Examination

Course Code: AUT 1302

Time: 2 Hour

**Course Name: Automotive Breaking, Suspension
and Steering System**

Max. Marks: 50

Instruction:

1. All the questions are compulsory to attend.
2. Students are not allowed to bring any smart device or cell phone in the exam hall.
3. Marks will be deducted if any overwriting in words will be found.

Section – A

10X01 = 10 Marks

1. Which of the following steering system works on turning and sliding mechanism?
 - a) Ackermann
 - b) a & b
 - c) Davis
 - d) None of the above
2. Which of these were or are being used in automobiles to provide suspension?
 - a) Leaf springs
 - b) Coil springs
 - c) Torsion bars
 - d) All of the mentioned
3. What is the full form of ESP system?
 - a) Electronic Stability Program
 - b) Engine Stability Program
 - c) Electronic Steering Program
 - d) None of above



BHARTIYA SKILL DEVELOPMENT UNIVERSITY

4. Which one of these is not the part of electric steering system?
 - a) Hydraulic Pump
 - b) Electric Motor
 - c) Steering wheel
 - d) Rack and pinion

5. What is Macpherson strut system?
 - a) Steering system
 - b) Suspension system
 - c) Braking system
 - d) None of these

6. Which parts of an automobile is first suspension for the vehicle?
 - a) Leaves of leaf spring
 - b) Coil Spring
 - c) Tires
 - d) None of the above

7. The type of axle which is used to transmit power is.....
 - a) Dead axle
 - b) Live axle
 - c) both (a) & (b)
 - d) None of the above

8. Which type of suspension system is used in the Honda City?
 - a) Macpherson strut system
 - b) Wish Bone system
 - c) Rigid suspension system
 - d) None of the above

9. If a person turns the steering wheel 220 degrees then how much should the wheel turns while having a steering ratio of 20:2?
 - a) 11 degrees
 - b) 120 degrees
 - c) 22 degrees
 - d) None of the above

10. Which material is used to manufacture backing plate in braking system?
 - a) Mild Steel
 - b) Spring Steel
 - c) Stamped Steel
 - d) High Carbon Steel

Section – B

04X04 = 16 Marks

11. Explain the new technologies we are using in braking system.
12. What are the purposes of Independent suspension system?
13. Write the components of Electrical steering system.
14. Suppose a vehicle is having a problem of "Steering Pull", write the process of diagnosis and repair according to you.



BHARTIYA SKILL DEVELOPMENT UNIVERSITY

Section – C

04X06 = 24 Marks

15. Write down the process of suspension frame replacement of Honda city?
16. What is ABS? Explain all the components of ABS.
17. Write down the process of drive axle replacement?
18. Explain the components of Hydraulic electric steering system mechanism.

Vikram



Registration No.:

BHARTIYA SKILL DEVELOPMENT UNIVERSITY

School of Automotive Skills
Session: 2021-22 (Summer Semester)
B. Voc. Program, 3rd Semester,
End Sem. Examination

Course Code: AUT 1302

Time: 2 Hour

Course Name: Automotive Breaking, Suspension
and Steering System

Max. Marks: 50

Instruction:

1. All the questions are compulsory to attend.
2. Students are not allowed to bring any smart device or cell phone in the exam hall.
3. Marks will be deducted if any overwriting in words will be found.

Section – A

10X01 = 10 Marks

1. Which of the following steering system works on turning and sliding mechanism?
a) Ackermann
b) a & b
c) Davis
d) None of the above
2. Which of these were or are being used in automobiles to provide suspension
a) Leaf springs
b) Coil springs
c) Torsion bars
d) **All of the mentioned**
3. What is the full form of ESP system?
a) **Electronic Stability Program**
b) Engine Stability Program
c) Electronic Steering Program
d) None of above

BHARTIYA SKILL DEVELOPMENT UNIVERSITY

used in the front **suspension** of modern vehicles and is named for American automotive engineer Earle S. **MacPherson**, who originally invented and developed the design.

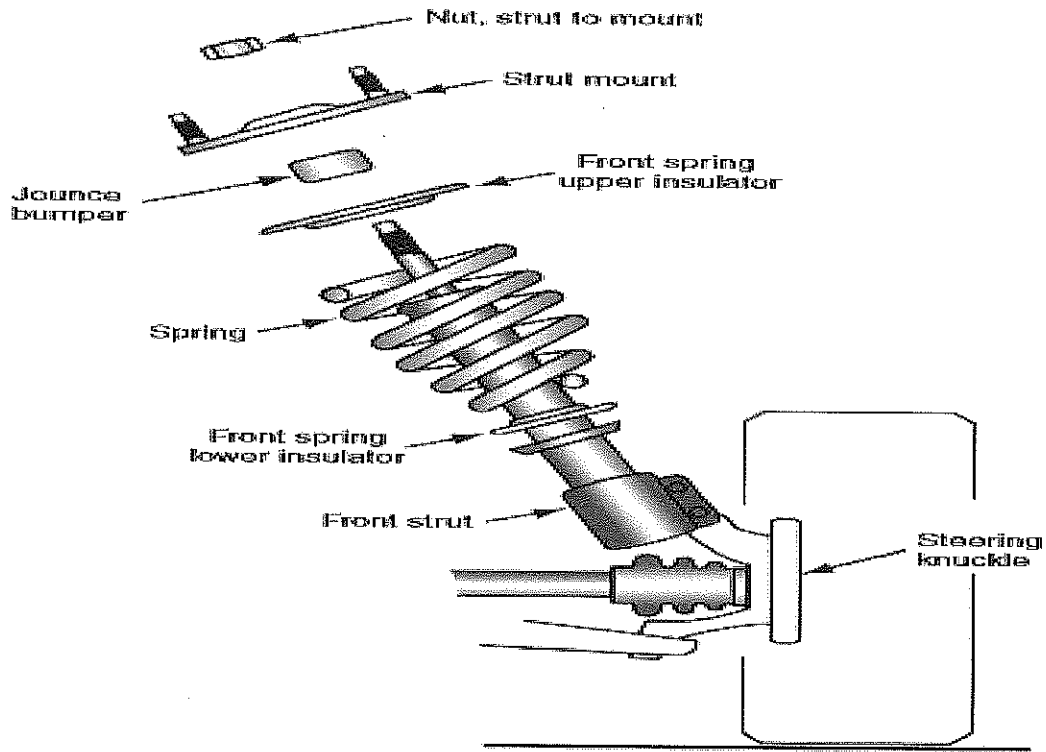
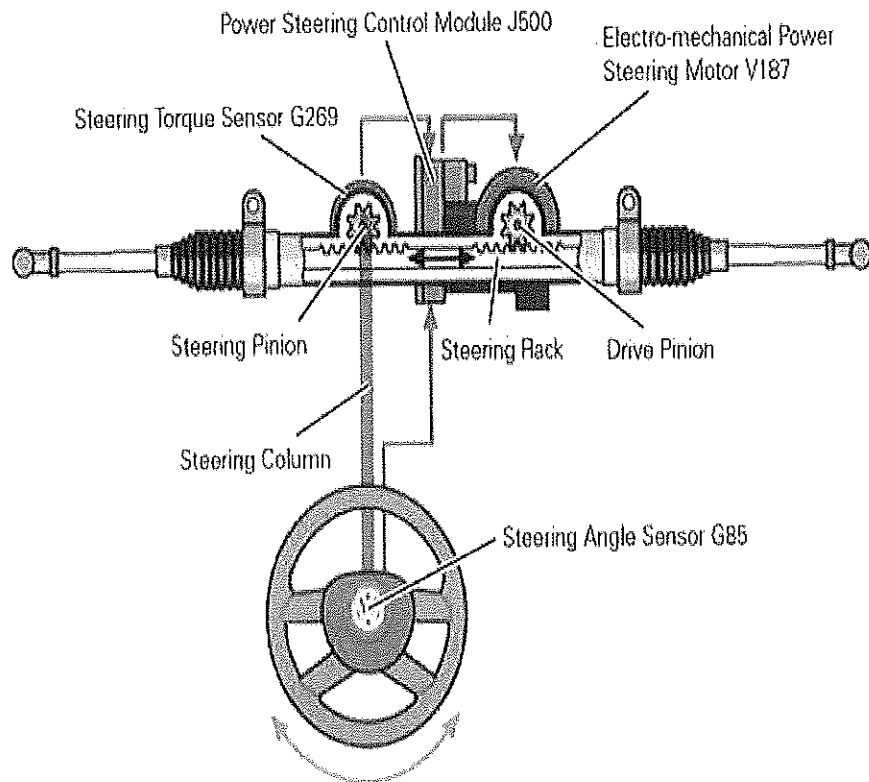

FIGURE 5-5 Front strut assembly.

13. Write the components of Electrical steering system.

- Ans. **Electric power steering system (EPS):** EPS is also similar to hydraulic steering system the only difference is, it use torque sensor and electric motor in place of hydraulic pump. Electric power steering system control by ECM (electronic control module).

BHARTIYA SKILL DEVELOPMENT UNIVERSITY



14. Suppose a vehicle is having a problem of "Steering Pull", write the process of diagnosis and repair according to you.

Ans. **STEP 1** Verify the customer complaint. For example, common drum brake concerns include:

- Low brake pedal
- Parking brake does not hold the vehicle on a hill
- Noise while braking
- Noise when the vehicle is moving, but the brakes are not applied.

STEP 2 Perform a visual inspection of the brakes and related parts, such as the wheels, tires, and suspension system.

STEP 3 Determine the root cause. For example, this could include determining that the parking brake linkage is corroded causing the brake shoes to wear. Replacing just the brake shoes will not correct the root cause.

STEP 4 Restore the brake system to like-new operation, which is the purpose of any repair.

STEP 5 Test-drive the vehicle to verify that the service has corrected the customer's complaint.

BHARTIYA SKILL DEVELOPMENT UNIVERSITY

Section – C

04X06 = 24 Marks

15. Write down the process of suspension frame replacement of Honda city?

Ans. The following steps are of suspension frame replacement:

1. Removal of wheel
2. Remove shock absorber mounting bolts
3. Removal of suspension frame
4. Removal of balancing rod
5. Removal of steering mounting
6. Removal of frame
7. Reverse the process for assembly.

16. What is ABS? Explain all the components of ABS.

Ans. **Antilock braking systems (ABS)** help prevent the wheels from locking during sudden braking, especially on slippery surfaces. This helps the driver maintain control. Antilock brakes increase safety because they eliminate lockup and minimize the danger of skidding, allowing the vehicle to stop in a straight line. ABS also allows the driver to maintain steering control during heavy braking so the vehicle can be steered to avoid an obstacle or another vehicle.

- **On dry or wet pavement, maximum braking traction occurs when tire slip is held between approximately 15% and 30%.**

17. Write down the process of drive axle replacement?

Ans. The following is the process for drive axle replacement:

1. Remove the wheel
2. Remove the hub bolt
3. Remove the shocker hub bolt
4. Remove the wheel hub from suspension arm
5. Adjust the wheel hub side to side
6. Remove the drive axle shaft
7. Reverse the process for assembly

18. Explain the components of Hydraulic electric steering system mechanism.

BHARTIYA SKILL DEVELOPMENT UNIVERSITY

Ans.

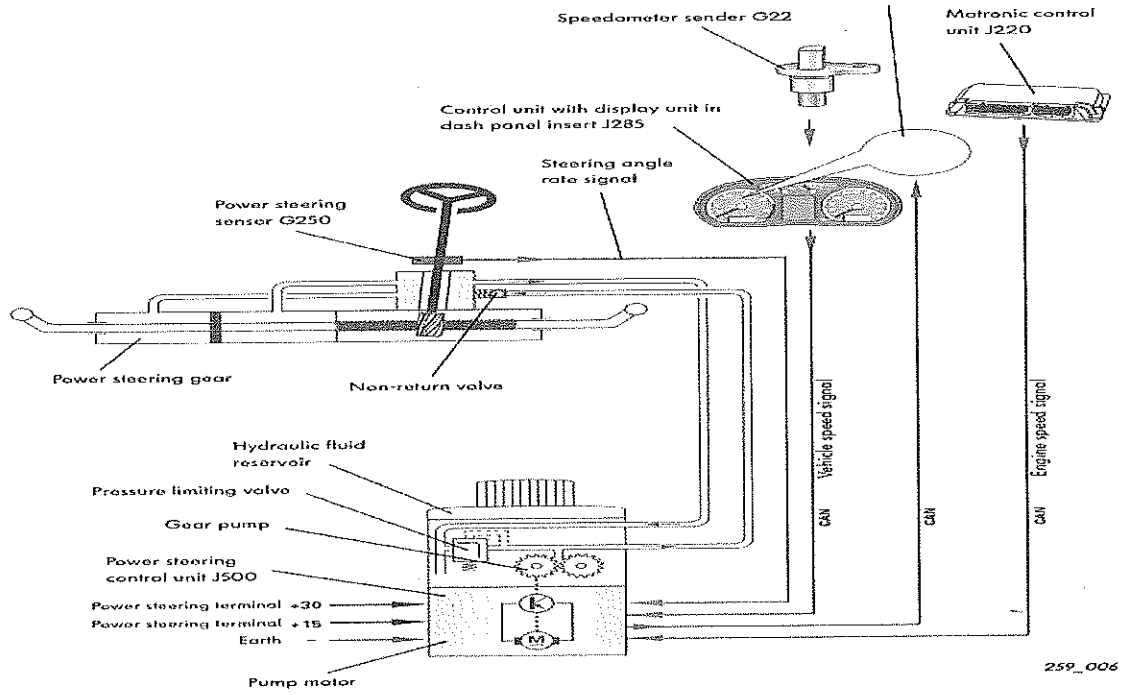

259_006

Vipin

Set A, 01

Registration No.:

School of Automotive Skills
Session: 2021-22 (Summer Semester)
B. Voc. Program, 3rd Semester
End Sem. Examination

Course Code: AUT1303
Course Name: Automotive Body Works

Time: 2 Hour
Max. Marks: 50

Instruction:

1. Attempt all questions.
2. Use of Calculators is prohibited.
3. Section A contains 10 Questions. Each question carries 1 Marks.
4. Section B contains 4 Questions. Each question carries 4 Marks.
5. Section C contains 4 Questions. Each question carries 6 Marks.

Section – A

10X01 = 10 Marks

Q1. remover is essential for cleaning the surface prior to sanding or spraying undercoats or to coats.

- | | |
|-------------------|----------------|
| a) Wax and grease | c) Body filler |
| b) Putty | d) Seam sealer |

Q2. is the event in which two or more bodies exert forces on each other in about a relatively short time.

- | | |
|------------|--------------|
| a) Denting | c) Clamping |
| b) Bending | d) Collision |

Q3. is an essential tool for the quick removal of paint, primer and old body filler from an area being repaired?

- a) Sliding hammers
- b) Sander
- c) Shears
- d) Nibblers

Q4. is used to prevent moisture from getting into seams of a car.

- a) Degreaser
- b) Putty
- c) Body filler
- d) Seam sealer

Q5. is a lightweight, extremely strong, and robust material.

- a) Sheet metal
- b) Diamond
- c) Chassis
- d) Fiberglass

Q6. are typically used for hammer-forming flat sheet metal into custom shapes.

- a) Sliding hammers
- b) Mallets
- c) Shears
- d) Nibblers

Q7. A stamping tool is used for the dented panel.

- a) Restoring Bodyline
- b) Making Holes
- c) Pulling out dents
- d) Pressing

Q8. Serrate head hammers are used for.....

- a) shrinking metal
- b) Panel flattening
- c) Restoring Bodylines
- d) All of the above

Q9. Removing and installing a new panel or body part is called:

- a) Major repair
- b) Minor Repair
- c) Paint selection
- d) Panel replacement

Q10. A slide hammer is used for in sheet metal.

- a) Restoring Bodyline
- b) Making Holes
- c) Pulling out dents
- d) None of these



BHARTIYA SKILL DEVELOPMENT UNIVERSITY

Section – B

04X04 = 16 Marks

Q11. What are the advantages of using sanding blocks during dry sanding?

Q12. Describe the types of body hammers used in a body shop.

Q13. Write the names of different tools used in auto bodywork.

Q14. What are the advantages and disadvantages of chemical stripping?

Section – C

04X06 = 24 Marks

Q15. Write steps to remove front bumper assembly.

Q16. Write short notes on:

- a) Seam sealer
- b) Sand paper

Q17. Discuss the different categories of body filler.

Q18. Discuss the panel beating processes and also mention the differences between dolly-on and dolly-off hammering.

Vijay

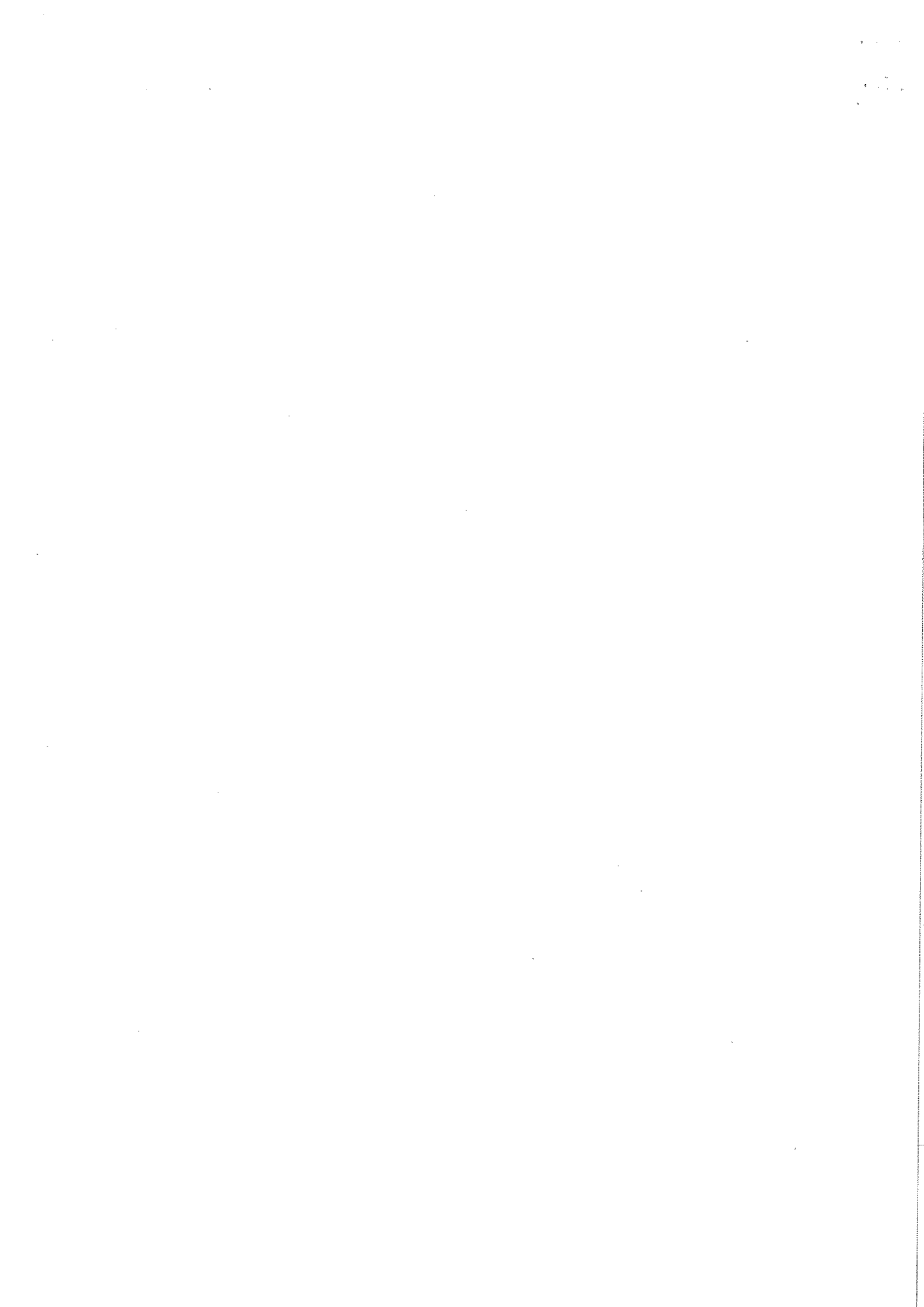

Registration No.:

School of Automotive Skills
Session: 2021-22 (Summer Semester)
B. Voc. Program, 3rd Semester

Answer sheet (Set A) End Sem. Examination

Course Code: AUT1303

Time: 2 Hour

Course Name: Automotive Body Works

Max. Marks: 50

Instruction:

1. Attempt all questions.
2. Use of Calculators is prohibited.
3. Section A contains 10 Questions. Each question carries 1 Marks.
4. Section B contains 4 Questions. Each question carries 4 Marks.
5. Section C contains 4 Questions. Each question carries 6 Marks.

Section – A

10X01 = 10 Marks

Q1. remover is essential for cleaning the surface prior to sanding or spraying undercoats or to coats.

- | | |
|-------------------|----------------|
| a) Wax and grease | c) Body filler |
| b) Putty | d) Seam sealer |

Q2. is the event in which two or more bodies exert forces on each other in about a relatively short time.

- | | |
|------------|--------------|
| a) Denting | c) Clamping |
| b) Bending | d) Collision |

Q3. is an essential tool for the quick removal of paint, primer and old body filler from an area being repaired?

- a) Sliding hammers
- b) Sander
- c) Shears
- d) Nibblers

Q4. is used to prevent moisture from getting into seams of a car.

- a) Degreaser
- b) Putty
- c) Body filler
- d) **Seam sealer**

Q5. is a lightweight, extremely strong, and robust material.

- a) Sheet metal
- b) Diamond
- c) Chassis
- d) **Fiberglass**

Q6. are typically used for hammer-forming flat sheet metal into custom shapes.

- a) Sliding hammers
- b) **Mallets**
- c) Shears
- d) Nibblers

Q7. A stamping tool is used for the dented panel.

- a) Restoring Bodyline
- b) Making Holes
- c) Pulling out dents
- d) **Pressing**

Q8. Serrate head hammers are used for.....

- a) **shrinking metal**
- b) Panel flattening
- c) Restoring Bodylines
- d) All of the above

Q9. Removing and installing a new panel or body part is called:

- a) Major repair
- b) Minor Repair
- c) Paint selection
- d) **Panel replacement**

Q10. A slide hammer is used for in sheet metal.

- a) Restoring Bodyline
- b) Making Holes
- c) **Pulling out dents**
- d) None of these



Q11. What are the advantages of using sanding blocks during dry sanding?

Ans: -

- Sanding blocks are commercially available in a wide variety of shapes, styles, size, and materials.
- Sanding can help you to get the best results, but without a sanding block you'll be wasting your time.
- Sanding blocks help you to exert even pressure on the sandpaper, while minimizing waves in the panel being sanded.

Q12. Describe the types of body hammers used in a body shop.

Ans: -

Body hammer come in a variety of shapes, sizes, and uses.

- Those with a serrate head are used for shrinking metal.
- Round heads are used for general panel flattening.
- While square heads are used for restoring bodylines.

Q13. Write the names of different tools used in auto bodywork.

Ans: - Basic tools like hammers, mallets, dollies, sanding blocks, spoons, portable grinders and sanders, stud welders and slide hammers, panel flangers, pneumatic tools, chisel, nibblers, clamps, etc.

Q14. What are the advantages and disadvantages of chemical stripping?

Ans: -

Advantages

- It is used to remove all types of liquid as well as powder paints, lacquers, enamels & polyurethanes from the metal surface.
- It reduces the cleaning effort.
- It saves time.
- It strips large area like doors, panel, bonnet, etc.
- Capability to strip tough configurations.

Disadvantages

- It couldn't be applicable for plastic materials like front and rear bumper.
- Waste could be hazardous.
- It causes irritation while contact to our skins.
- Slow stripping rate.

Section – C

04X06 = 24 Marks

Q15. Write steps to remove front bumper assembly.

Ans: - Step 1- Remove Front Beauty Cover



BHARTIYA SKILL DEVELOPMENT UNIVERSITY

Once all pins are removed, peel back the weather stripping to loosen the cover.

- Pins locations shown with arrows in the photo below. Once free, set the cover aside.

Step 2- Remove Plastic fasteners

- Remove the plastic fasteners on the upper portion of the front bumper on each side.
- Use a flathead screw driver or the appropriate removal tool and pry upward.

Step 3 - Remove Upper portion bolts

- Remove the 10mm Bolts on the upper portion of the bumper as pictured.

step 4 - Remove Clips from Under Bumper

- Remove push pin clips from the bottom side of the bumper which hold the splash shield in place.
- Use a flathead screw driver or the appropriate removal tool and pry away.

Step 5 - Remove Clips from the fender areas

- Use a flathead screw driver or the appropriate removal tool and pry away.

Step 6 - Remove Front Clip

- Pull sides of front bumper outward until retention clips release on driver and passenger side.
- See photo below for arrows showing location of retention clips.
- After each side is successfully released, remove front bumper by pulling forward from the grill area. You will not be fully removing the bumper from the car at this moment.

Step 7 - Remove Fog Light Clips and Head Lamp Washer

Step 8 - Complete Removing the Front Bumper

- Fully remove the front bumper by continuing to pull forward in a slow motion.
- If removing the bumper yourself, its recommended to place a towel/blanket on the ground so that you do not scrape anything if dragged or dropped on the ground.

Q16. Write short notes on:

- a) Seam sealer
- b) Sand paper

Ans:- **Seam Sealer**

- Seam sealer is used to prevent moisture from getting into seams of a car.
- Where two panels join, there is a chance water and moisture can get in and start corroding the panels. Therefore, seam sealer is applied to prevent corrosion from happening.

Sand Paper

- Sandpaper and Glass-paper are names used for a type of coated abrasive that consists of sheet of paper or cloth with abrasive material glued to one face.
- Despite the use of names sand or glass, they have been replaced by other abrasives such as aluminium oxide or silicon carbide.
- Sandpaper is produced in a range of grit sizes and is used to remove material from surfaces; either to make them smoother (for example, in painting and wood finishing), to remove a layer of material (such as old paint), or sometimes to make the surface rougher (for example, as a preparation for gluing).



Q17. Discuss the different categories of body filler.

Ans: - Body fillers are generally polyester resin based filler with a creme hardener that can be used to even out dents and cover blemishes on vehicles.

- Body fillers all fall into three general categories: standard, mid-range, and premium, and are generally available in a two-part material consisting of a polyester resin and a creme hardener.
- The filler grade you select will depend on the scope of the project and the size of the damaged spots needing to be repaired.
- Standard grade is a great option for minimal hail damage and small rust spots, while premium grade should be used for actual tears or a large surface area.

Q18. Discuss the panel beating processes and also mention the differences between dolly-on and dolly-off hammering.

Ans: -

After an accident, a car's body may be severely damaged and bent out of shape. The dents and breakages need to be beaten and smoothed back to shape. This entire process is referred to as panel beating and is usually carried out by panel beaters using specialized tools and techniques. A good panel beating should result in a smooth and nearly new appearance without small dents and uneven bumps. Here is a brief description of the processes carried out during panel beating.

Tools Required;

- Dolly & hammer set
- Spoons
- Mallet

The first step to fix a dent would be to stretch the metal back into shape. This is done by heating the dented area with a blow torch and, once well heated, the panel beaters hammer the metal slowly to stretch it back to shape. A shrink hammer is used to beat the metal all while another tool called a dolly is laid back on the panel to give it shape.

Putty may sometimes be used to fill small dents and holes. Panel beaters prepare putty mix and quickly set it into the dents while shaping all through. Putty must be set quickly since it hardens fast. Once applied, the putty filler hardens and the panel beaters can then sand and smooth it before primer is set. Putty fillers should be carefully and quickly prepared and laid to ensure a smooth finish.

Dolly- on hammering

- Hold dolly against back of damage and hammer right over to of dolly.
- Repeatedly move point of hammer impact and dolly slightly, each blow overlapping.
- Start at outside and work towards center.
- Shapes of dolly and hammer must match desired shape of panel.
- Start with light hammer blows, and work up to stronger blows.

Dolly-off hammering

- It is used to raise low spots and lower high spot simultaneously.
- The hammer hits the panel slightly to one side of where the dolly is being held.
- It is often used to rough out or shape large areas of damage during initial straightening.

Vipin

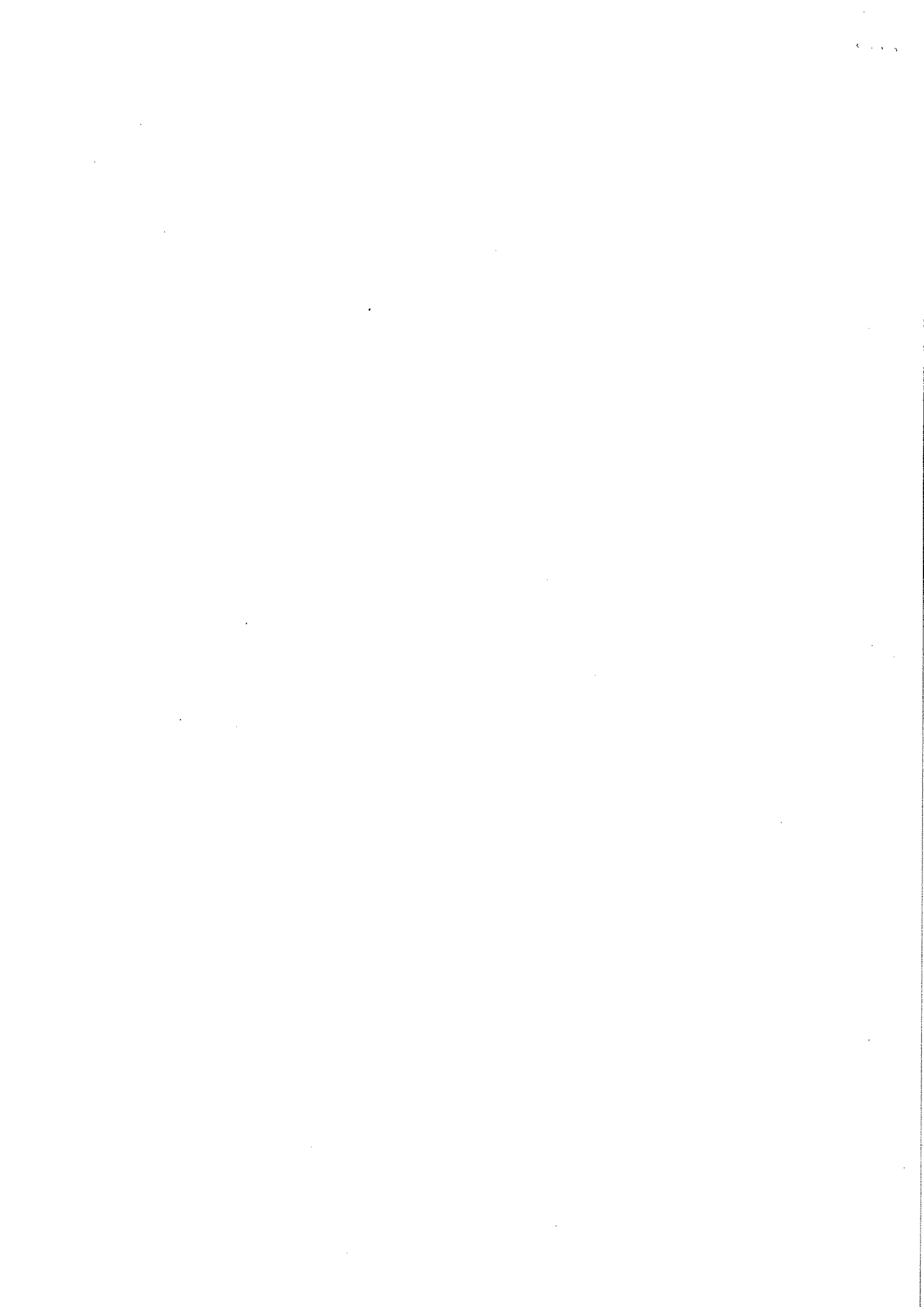

School of Automotive Skills
Session: 2021-22 (Summer Semester)
B. Voc. Program, 3rd Semester
End Sem. Examination

Course Code: AUT1303
Course Name: Automotive Body Works

Time: 2 Hour
Max. Marks: 50

Instruction:

1. Attempt all questions.
2. Use of Calculators is prohibited.
3. Section A contains 10 Questions. Each question carries 1 Marks.
4. Section B contains 4 Questions. Each question carries 4 Marks.
5. Section C contains 4 Questions. Each question carries 6 Marks.

Section – A

10X01 = 10 Marks

Q1. The gap between the electrode rod and the work piece should be about

- | | |
|-----------------------------|---------------------------|
| a) The electrode diameter | c) 5 mm |
| b) The work piece thickness | d) the core wire diameter |

Q2. Plasma is a state of matter consisting of..... gas.

- | | |
|-------------------|-------------|
| a) Hydrogen | c) Nitrogen |
| b) Carbon dioxide | d) Ionized |

Q3. Removing and installing a new panel or body part is called:

- a) Major repair
- b) Minor Repair
- c) Paint selection
- d) Panel replacement

Q4. A slide hammer is used forin sheet metal.

- | | |
|-----------------------|----------------------|
| a) Restoring Bodyline | c) Pulling out dents |
| b) Making Holes | d) None of these |

Q5. is an essential tool for the quick removal of paint, primer and old body filler from an area being repaired?

- | | |
|--------------------|------------|
| a) Sliding hammers | d) Nibbler |
| b) Sander | |
| c) Shears | |



BHARTIYA SKILL DEVELOPMENT UNIVERSITY

Q6. is a lightweight, extremely strong, and robust material.

- a) Sheet metal
- b) Diamond
- c) Chassis
- d) Fiberglass

Q7. are typically used for hammer-forming flat sheet metal into custom shapes.

- a) Sliding hammers
- b) Mallets
- c) Shears
- d) Nibblers

Q8. remover is essential for cleaning the surface prior to sanding or spraying undercoats or to coats.

- a) Wax and grease
- b) Putty
- c) Body filler
- d) Seam sealer

Q9. is used to prevent moisture from getting into seams of a car.

- a) Degreaser
- b) Putty
- c) Body filler
- d) Seam sealer

Q10. For GMAW welding, electrode is used.

- a) Consumable
- b) Non-consumable
- c) filler
- d) None of the above

Section – B

04X04 = 16 Marks

Q11. What is the difference between mallet and hammer?

Q12. What is the use of spoons in an auto body repair?

Q13. What are the advantages and disadvantages of chemical stripping?

Q14. What is the difference between mallet and hammer?

Section – C

04X06 = 24 Marks

Q15. Discuss the panel beating processes and also mention the differences between dolly-on and dolly-off hammering.

Q16. Write steps to remove front bumper assembly.

Q17. How to repair rusted Panels?

Q18. How to Replace a Windshield?

School of Automotive Skills
Session: 2021-22 (Summer Semester)
B. Voc. Program, 3rd Semester
Answer sheet (Set B) End Sem. Examination

Course Code: AUT1303

Time: 2 Hour

Course Name: Automotive Body Works

Max. Marks: 50

Instruction:

1. Attempt all questions.
2. Use of Calculators is prohibited.
3. Section A contains 10 Questions. Each question carries 1 Marks.
4. Section B contains 4 Questions. Each question carries 4 Marks.
5. Section C contains 4 Questions. Each question carries 6 Marks.

Section – A

10X01 = 10 Marks

Q1. The gap between the electrode rod and the work piece should be about

- | | |
|-----------------------------|---------------------------|
| a) The electrode diameter | c) 5 mm |
| b) The work piece thickness | d) the core wire diameter |

Q2. Plasma is a state of matter consisting of..... gas.

- | | |
|-------------------|-------------|
| a) Hydrogen | c) Nitrogen |
| c) Carbon dioxide | d) Ionized |

Q3. Removing and installing a new panel or body part is called:

- a) Major repair
- b) Minor Repair
- c) Paint selection
- d) **Panel replacement**

Q4. A slide hammer is used forin sheet metal.

- | | |
|-----------------------|-----------------------------|
| a) Restoring Bodyline | c) Pulling out dents |
| b) Making Holes | d) None of these |

Q5. is an essential tool for the quick removal of paint, primer and old body filler from an area being repaired?

- | | |
|--------------------|------------|
| a) Sliding hammers | c) Shears |
| b) Sander | d) Nibbler |

Q6. is a lightweight, extremely strong, and robust material.

- a) Sheet metal
- a) Diamond
- b) Chassis
- c) **Fiberglass**

Q7.are typically used for hammer-forming flat sheet metal into custom shapes.

- a) Sliding hammers
- b) **Mallets**
- c) Shears
- d) Nibblers

Q8. remover is essential for cleaning the surface prior to sanding or spraying undercoats or to coats.

- a) **Wax and grease**
- b) Putty
- c) Body filler
- d) Seam sealer

Q9.is used to prevent moisture from getting into seams of a car.

- a) Degreaser
- b) Putty
- c) Body filler
- d) **Seam sealer**

Q10. For GMAW welding..... electrode is used.

- a) **Consumable**
- b) Non-consumable
- c) filler
- d) None of the above



Q11. What is the difference between mallet and hammer?

Ans: -

A **hammer** is made of hardened steel and has, depending on its purpose, either a claw for prying, or a hatchet type blade generally use for roofing.

A **mallet** is a kind of hammer, often made of rubber or sometimes wood, that is smaller than a maul or beetle, and usually has a relatively large head. The term is descriptive of the overall size and proportions of the tool, and not the materials it may be made of, though most mallets have striking faces that are softer than steel.

Q12. What is the use of spoons in an auto body repair?

Ans: -

- Designed for used inside hard-to-reach areas.
- Spoons function like a body dolly with a handle.
- Often smaller and thinner than a dolly, they can be used inside of doors, fenders, hoods, or other double wall panels.
- They can also be used for prying panels outward from behind.

Q13. What are the advantages and disadvantages of chemical stripping?

Ans: -

Advantages

- It is used to remove all types of liquid as well as powder paints, lacquers, enamels & polyurethanes from the metal surface.
- It reduces the cleaning effort.
- It saves time.
- It strips large area like doors, panel, bonnet, etc.
- Capability to strip tough configurations.

Disadvantages

- It couldn't be applicable for plastic materials like front and rear bumper.
- Waste could be hazardous.
- It causes irritation while contact to our skins.
- Slow stripping rate.

Q14. What is the difference between mallet and hammer?

Ans: -

- A **hammer** is made of hardened steel and has, depending on its purpose, either a claw for prying, or a hatchet type blade generally use for roofing.
- A **mallet** is a kind of hammer, often made of rubber or sometimes wood, that is smaller than a maul or beetle, and usually has a relatively large head. The term is descriptive of the overall size and proportions of the tool, and not the materials it may be made of, though most mallets have striking faces that are softer than steel



BHARTIYA SKILL DEVELOPMENT UNIVERSITY

Section – C

04X06 = 24 Marks

Q15. Discuss the panel beating processes and also mention the differences between dolly-on and dolly-off hammering.

Ans: -

After an accident, a car's body may be severely damaged and bent out of shape. The dents and breakages need to be beaten and smoothed back to shape. This entire process is referred to as panel beating and is usually carried out by panel beaters using specialized tools and techniques. A good panel beating should result in a smooth and nearly new appearance without small dents and uneven bumps. Here is a brief description of the processes carried out during panel beating.

Tools Required;

- Dolly & hammer set
- Spoons
- Mallet

The first step to fix a dent would be to stretch the metal back into shape. This is done by heating the dented area with a blow torch and, once well heated, the panel beaters hammer the metal slowly to stretch it back to shape. A shrink hammer is used to beat the metal all while another tool called a dolly is laid back on the panel to give it shape.

Putty may sometimes be used to fill small dents and holes. Panel beaters prepare putty mix and quickly set it into the dents while shaping all through. Putty must be set quickly since it hardens fast. Once applied, the putty filler hardens and the panel beaters can then sand and smooth it before primer is set. Putty fillers should be carefully and quickly prepared and laid to ensure a smooth finish.

Dolly- on hammering

- Hold dolly against back of damage and hammer right over to of dolly.
- Repeatedly move point of hammer impact and dolly slightly, each blow overlapping.
- Start at outside and work towards center.
- Shapes of dolly and hammer must match desired shape of panel.
- Start with light hammer blows, and work up to stronger blows.

Dolly-off hammering

- It is used to raise low spots and lower high sport simultaneously.
- The hammer hits the panel slightly to one side of where the dolly is being held.
- It is often used to rough out or shape large areas of damage during initial straightening.

Q16. Write steps to remove front bumper assembly.

Ans: - Step 1- Remove Front Beauty Cover

- Remove plastic push-pins holding the top plastic shroud that rests on top of the front clip and extends around the engine bay, including the weather-stripping used to seal out water.
- Once all pins are removed, peel back the weather stripping to loosen the cover.
- Pins locations shown with arrows in the photo below. Once free, set the cover aside.

Step 2- Remove Plastic fasteners

- Remove the plastic fasteners on the upper portion of the front bumper on each side.



BHARTIYA SKILL DEVELOPMENT UNIVERSITY

Step 3 - Remove Upper portion bolts

- Remove the 10mm Bolts on the upper portion of the bumper as pictured.

Step 4 - Remove Clips from Under Bumper

- Remove push pin clips from the bottom side of the bumper which hold the splash shield in place.
- Use a flathead screw driver or the appropriate removal tool and pry away.

Step 5 - Remove Clips from the fender areas

- Use a flathead screw driver or the appropriate removal tool and pry away.

Step 6 - Remove Front Clip

- Pull sides of front bumper outward until retention clips release on driver and passenger side.
- See photo below for arrows showing location of retention clips.
- After each side is successfully released, remove front bumper by pulling forward from the grill area. You will not be fully removing the bumper from the car at this moment.

Step 7 - Remove Fog Light Clips and Head Lamp Washer

Step 8 - Complete Removing the Front Bumper

- Fully remove the front bumper by continuing to pull forward in a slow motion.
- If removing the bumper yourself, it's recommended to place a towel/blanket on the ground so that you do not scrape anything if dragged or dropped on the ground.

Q17. How to repair rusted Panels?

Ans: -

Although we usually envision collision repair whenever we think of automotive bodywork, rust repair is often just as common. Rust may be rare in some regions, but it is all too common in the rest of the world.

Anywhere that humidity meets unprotected sheet metal, rust is hard at work eating its way through your automobile's sheet metal. Sadly, you may not even know that the rust is present, as it tends to do its damage to areas of your vehicle that you don't normally see during everyday operation. When you're dealing with rust, you should determine whether it is just surface rust or a rust-through.

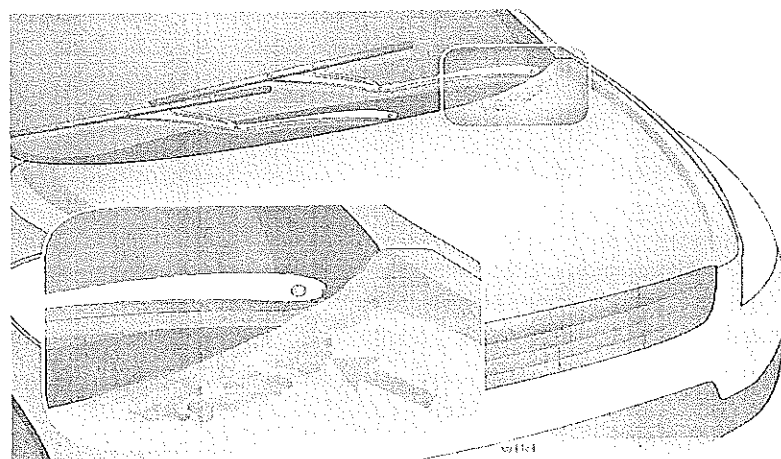

MINOR SURFACE RUST REMOVAL

- 1) Mask off the affected area with paint-appropriate tape. You want a few inches of protection



BHARTIYA SKILL DEVELOPMENT UNIVERSITY

- 2) Follow the directions on the rust remover, usually spraying or brushing it onto the rust and letting it sit for a few minutes. Then, wipe off any residue with a clean rag. Remember that rust remover is nasty stuff, so be sure to wear the appropriate protective gear when handling it.
- 3) The rust should be gone, but remove any leftover rust with sandpaper.
- 4) Clean with a grease and wax remover soap, then air dry.
- 5) Spray primer in a light-to-medium coat, and allow an hour to dry. Spray three coats.
- 6) Spray the color base coat, going thinner than the primer. You may have to do five or six coats for complete coverage. Give it plenty of time between coats to prevent drips.
- 7) Spray the clear coat. Wait two or 3 days before washing, and wait a minimum of two months (some body shops suggest waiting for six) before waxing.

MAJOR RUST REMOVAL

- 1) Mask off the affected area. If sanding through paint and primer, cover the rest of the vehicle to protect it from the super-fine dust.
- 2) Use a grinder with a sanding wheel to remove as much surface rust as you can. When removing the rust, remember not to bear down any heavier than you absolutely need to.
- 3) Clean the work area with grease remover.
- 4) Use a fiberglass-reinforced body filler for holes and depressions left over after digging out the rust. Allow it to cure completely. This could take quite some time, and shouldn't be done at all if it's any cooler than about 65 degrees outside.
- 5) Sand the filler with progressively finer grit sandpaper, and then clean with wax and grease remover.
- 6) Tape off the area to be painted.
- 7) Use the self-etching primer and wait the required drying time.
- 8) Spray several light coats of paint.
- 9) Finish with a coat or two of clear. Like above, hold off on washing and waxing.

Q18. How to Replace a Windshield?

Ans: -

- There are basically two types of windows in an automobile: fixed glass and opening glass. Fixed glass is used in windows that do not open, such as the windshield, back window, and rear quarter windows.
- Glass from fixed windows is taken out by first removing any trim around the window seal, removing the rubber by using a special tool designed for the task, then pushing the window glass outward. Any residual window caulk or sealant must be removed from the sheet metal around the window opening. Some of these windows are glued in place, while others are held in place by rubber weather strip. For the type that is glued in place, the sheet metal window opening must be free of debris or broken glass and clean and free of contaminants; this can be ensured by cleaning with wax and grease remover, then applying the glue to the flange in the window opening. The glass is then set into position and pressed into place to ensure full contact with the glue. Leave the vehicle for the proper amount of time for the glue to set.
- For the glass that is secured by weather strip, as with the glued-in type, the sheet metal window opening must be clean. The rubber weather strip is stretched around the window glass, making sure that the weather strip is properly oriented around the glass. Spray silicone is then applied to the inside lip of the weather strip and a thin cord or rope (about 1/8 inch in diameter) is slid into the lip that fits around the flange in the window opening. The cord or rope should overlap at the top or bottom of the glass so that it protrudes toward the inside of the vehicle long enough that you can hold opposite ends of the rope in each hand.
- With the help of an assistant, the glass and weather strip is set in place outside the vehicle. By pulling the rope inward (out of the weather strip), the weather strip can pass over the window opening flange. The cord or rope is pulled in slowly while the assistant outside of the vehicle pushes the glass in place.

Vijay



School of Automotive Skills
Session: 2021-22 (Summer Semester)
B. Voc. Program, 3rd Semester,
End-Sem. Examination

Course Code: AUT1304

Time: 2 Hour

Course Name: Automotive Refinish Painting

Max. Marks: 50

Instruction: Attempt all Questions.

Section – A

10X01 = 10 Marks

Q-1. Which type of paint is not environment friendly and safe for paint technician health?

- a. 2K Paint
- b. Synthetic Paint
- c. NC Paint
- d. All of the Above

Q-2. Why plastic panels are used in cars?

- a. It is light in Weight
- b. It is more flexible
- c. It reduces the appearance
- d. Both (a) & (b)

Q-3 Why plastic parts are painted?

- a. To enhance gloss
- b. To save from environmental influences
- c. Both (a) & (b)
- d. None of these

Q-4. What happen if plastic parts are not painted?

- a. It Degrade like other materials
- b. No effect occurs
- c. Both (a) & (b)

Q-5. Flexible additive decreases the paint flexibility.

- a. True
- b. False

Q-6. Is plastic primer applied after clear.

- a. True
- b. False

Q-7. Defects in paint arises due to.....?

- a. Adverse atmospheric conditions
- b. Mistakes during paint application
- c. Wrong selection of hardener and thinner
- d. All of the above

Q-8. High film thickness caused mottling.

- a. True
- b. False

Q-9. What are the causes of pin holes?

- a. Non recommended thinner used
- b. Improper degreasing
- c. Both a & b



BHARTIYA SKILL DEVELOPMENT UNIVERSITY

d. None of these

Q-10. How we can prevent for dust in the paint film.

- a. Maintain the paint booth regularly
- b. Make yourself dust free before entering the paint booth
- c. Both (a) & (b)
- d. None of these

Section – B

04X04 = 16 Marks

Q-11. Write a short note on sanding papers.

Q-12. Discuss the correct parameters of random orbital sander handling.

Q-13. Write the putty and primer sanding processes.

Q-14. Brief about shade cards.

Section – C

04X06 = 24 Marks

Q-15. Explain six refinish painting defects.

Q-16. Explain paint booth control Panel operations.

Q-17. Explain Different types of masking techniques and material which is required for masking.

Q-18. Explain about different types of paint booth filters.



School of Automotive Skills
Session: 2021-22 (Summer Semester)
B. Voc. Program, 3rd Semester,
End-Sem. Examination

Course Code: AUT1304

Time: 2 Hour

Course Name: Automotive Refinish Painting

Max. Marks: 50

Instruction: Attempt all Questions.

Section – A

10X01 = 10 Marks

Q-1. Which type of paint is not environment friendly and safe for paint technician health?

- a. 2K Paint
- b. Synthetic Paint
- c. NC Paint
- d. All of the Above

Q-2. Why plastic panels are used in cars?

- a. It is light in Weight
- b. It is more flexible
- c. It reduces the appearance
- d. Both (a) & (b)

Q-3 Why plastic parts are painted?

- a. To enhance gloss
- b. To save from environmental influences
- c. Both (a) & (b)
- d. None of these

Q-4. What happen if plastic parts are not painted?

- a. It degrade like other materials
- b. No effect occurs
- c. Both (a) & (b)

Q-5. Flexible additive decreases the paint flexibility.

- a. True
- b. False

Q-6. Is plastic primer applied after clear.

- a. True
- b. False

Q-7. Defects in paint arises due to.....?

- a. Adverse atmospheric conditions
- b. Mistakes during paint application
- c. Wrong selection of hardener and thinner
- d. All of the above

Q-8. High film thickness caused mottling.

- a. True
- b. False

Q-9. What are the causes of pin holes?

- a. Non recommended thinner used
- b. Improper degreasing
- c. Both (a) & (b)
- d. None of these

Q-10. How we can prevent for dust in the paint film.



BHARTIYA SKILL DEVELOPMENT UNIVERSITY

- c. Both (a) & (b)
- d. None of these

Section – B

04X04 = 16 Marks

Q-11. Write a short note on sanding papers.

Q-12. Discuss the correct parameters of random orbital sander handling.

Ans: The angle of gun should be 90 degrees to the panel.

2. The pressure of gun should be 2-3 bar.

3. The distance between the panel and gun should be 5-8 inches.

4. The discharge should be 2.5 rounds of the discharge knob.

5. Overlapping should be 50% in each lap.

Q-13. Write the putty and primer sanding processes.

Ans:

Q-14. Brief about shade cards.

Section – C

04X06 = 24 Marks

Q-15. Explain six refinish painting defects.

Ans.

Mottling/Clouding

Cause:

- > Incorrect quantity of thinner, usually under thinning.
- > Holding the gun too close to the job.
- > In correct spray gun pressure.
- > In sufficient time between coats.
- > Incorrect spray booth temperature.

Prevention:

- > Use recommended thinning ratio.
- > Choose suitable spray gun set up.
- > Follow flash off times between coats as recommended.
- > Do not pile-in heavy wet coats.

Remedy:

- > If mottling has occurred, allow color coat to set up, then apply another double coat using correct thinning ratio and spray technique. (Cross coating recommended.)
- > After clear had through-dried, sand surface and repaint.

Runs/Sagging

Cause:

- > In correct spraying viscosity, spraying technique, flash-off times between coats, and film thickness.
- > Defective Spray gun set up.
- > Incorrect spraying pressure
- > Temperature of paint, substrate or spray booth too low.
- > Incorrect choice of hardeners and thinners.

Prevention:

- > Follow application recommendations and technical data sheets.
- > Regulate fluid adjustment on spray gun to cut down flow of material.
- > Increase flash-time between coats.



Remedy:

- > In case of minor area affected cut the runs by sand paper P1500 and Polish
- > In case of major wait till complete drying and then Sand the runs and Re-paint

Q-16. Explain paint booth control Panel operations.

Ans.

Q-17. Explain Different types of masking techniques and material which is required for masking.

Ans In order to carry out this process of masking we have range of materials such as:-

- Masking Paper
- Plastic sheet masking
- Masking tapes
- Caps and plugs
- Masking rope

Masking Paper

Paper has been and is the material most used to mask or protect areas not to paint. It is used to resist the solvents and diluents containing in the paint. It has low acquisition cost and easy of placement on flat surfaces.

Plastic sheet masking

The plastic sheet masking has been the technological evolution of the paper in masking. It has characteristics of resistance to solvents, temperature and handling. The main advantage of using these films is the easy adaptation to the contours.

Masking tapes

Among the wide range of masking tapes on the market, we can classify them into three groups:

- General masking tapes
- Fine masking tapes
- Trim masking tapes

Plugs and caps

The use of plugs for masking or covering of nuts and both plain and threaded holes. Generally, are made of silicone because of its high resistance to solvents, temperature and handling.

Masking rope

Masking rope are self-adhesive foam strips used in holes and openings.

This type of masking material is used on the edges of the doors, hinged covers

The purpose of masking rope is to prevent the penetration of the spray paint into the hole.

Q-18. Explain about different types of paint booth filters.



BHARTIYA SKILL DEVELOPMENT UNIVERSITY

Registration No.:

School of Automotive Skills
Session: 2021-22 (Summer Semester)
B. Voc. Program, 3rd Semester,
End-Sem. Examination

Course Code: AUT1304

Time: 2 Hour

Course Name: Automotive Refinish Painting

Max. Marks: 50

Instruction: Attempt all Questions.

Section – A

10X01 = 10 Marks

Q-1. Which of the following paint layer is a part of OEM painting?

- a. Electrophoretic dip coat primer
- b. Epoxy primer
- c. Polyester putty
- d. Body filler?

Q-2. Which of the following components provide color to the paint?

- a. Binder
- b. Pigments
- c. Solvents
- d. Additive

Q-3. Which one of the parameter is not consider for spraying?

- a. Gun Distance
- b. Spray Gun Angle
- c. Gun Speed
- d. Spray Gun Height

Q-4. Which of the sander is having the highest rpm?

- a. a. Single action
- b. b. Hand block
- c. Double action
- d. None of the above

Q-5. What is the width of each layer in feather edging?

- c. 7-10 mm
- d. 0-5 mm
- e. 20-30 mm
- f. None of these

Q-6. How we can speed up the drying process of waterborne paints?



BHARTIYA SKILL DEVELOPMENT UNIVERSITY

- a. By increasing temperature of booth
- b. **By using external blowers**
- c. Both a & b
- d. None of these

Q-7. Defects in paint arises due to.....?

- a. Adverse atmospheric conditions
- b. Mistakes during paint application
- c. Wrong selection of hardener and thinner
- d. **All of the above**

Q-8. High film thickness caused mottling.

- a. **True**
- b. False

Q-9. What are the causes of pin holes?

- a. Non recommended thinner used
- b. Improper degreasing
- c. **Both (a) & (b)**
- d. None of these

Q-10. How we can prevent for dust in the paint film.

- a. Maintain the paint booth regularly
- b. Make yourself dust free before entering the paint booth
- c. **Both (a) & (b)**
- d. None of these

Section – B

04X04 = 16 Marks

Q-11. Write a short note on spray gun.

Ans Masking is a technique in which auto body masking tape is applied on the car to mask off the areas that should not be treated or painted.

Masking tape, also known as painter's tape, is a type of pressure-sensitive tape made of a thin and easy-to-tear paper, and an easily released pressure-sensitive adhesive.

Q-12. Discuss the correct parameters of paint mixing.

Ans The angle of gun should be 90 degrees to the panel.

- 2. The pressure of gun should be 2-3 bar.
- 3. The distance between the panel and gun should be 5-8 inches.
- 4. The discharge should be 2.5 rounds of the discharge knob.
- 5. Overlapping should be 50% in each lap.

Q-13. Write the putty and primer sanding processes.

Ans:

Section – C

04X06 = 24 Marks

Q-15. Draw and explain Hue circle diagram.

Ans

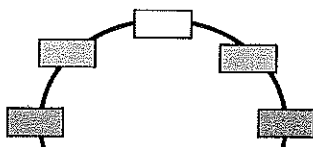



White, black and gray are "neutral" colors. They have no hue. Neutral colors are not more related to one hue than to any other. To show this on the hue circle diagram, we place neutral colors at the center

Q-16. Explain different types of masking papers and masking tapes.

Ans. In order to carry out this process of masking we have range of materials such as:-

- Masking Paper
- Plastic sheet masking
- Masking tapes
- Caps and plugs
- Masking rope

Masking Paper

Paper has been and is the material most used to mask or protect areas not to paint. It is used to resist the solvents and diluents containing in the paint. It has low acquisition cost and easy of placement on flat surfaces.

Plastic sheet masking

The plastic sheet masking has been the technological evolution of the paper in masking. It has characteristics of resistance to solvents, temperature and handling. The main advantage of using these films is the easy adaptation to the contours.

Masking tapes

Among the wide range of masking tapes on the market, we can classify them into three groups:

- General masking tapes
- Fine masking tapes
- Trim masking tapes

Plugs and caps

The use of plugs for masking or covering of nuts and both plain and threaded holes. Generally are made of silicone because of its high resistance to solvents, temperature and handling.

Masking rope

Masking rope are self-adhesive foam strips used in holes and openings.

This type of masking material is used on the edges of the doors, hinged covers

The purpose of masking rope is to prevent the penetration of the spray paint into the hole.

Q-17. Explain standard repair process.

Q.18. Write difference between solid color and Metallic color.

Vipin

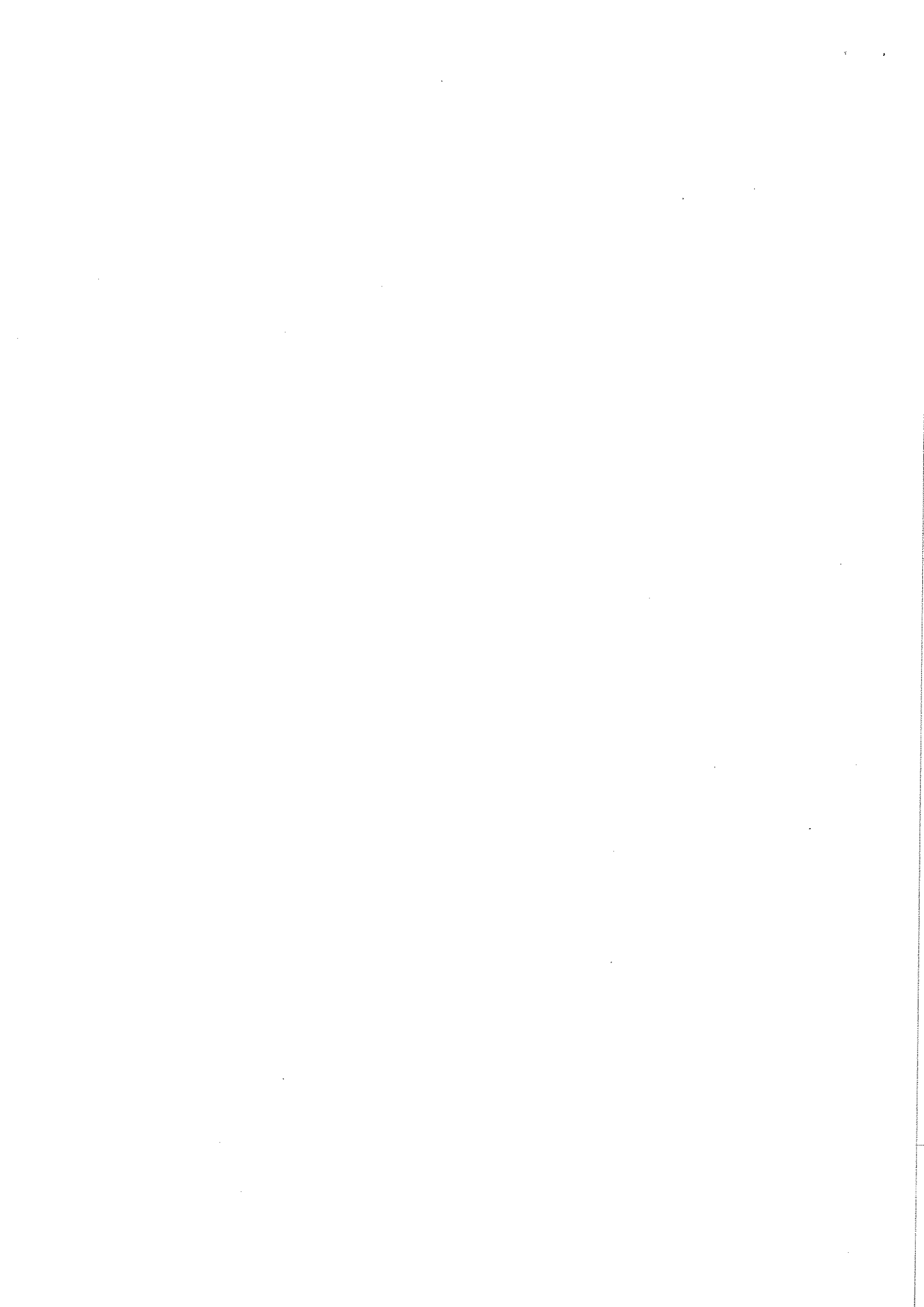



School of Automotive Skills
Session: 2021-22 (Summer Semester)
B. Voc. Program, 3rd Semester,
End-Sem. Examination

Course Code: AUT1305

Time: 2 Hours

Course Name: Automotive Electrical and AC

Max. Marks: 50

Instruction:

1. Answer all questions from section A, each question carries one mark.
2. Answer all questions from section B, each question carries four marks.
3. Answer all questions from section C, each question carries six marks.

Section – A

10X01 = 10 Marks

Q. 1 An ammeter is an electrical instrument used to measure:

- | | |
|------------|----------------------|
| a. Current | c. Resistance |
| b. Voltage | d. None of the above |

Q.2 The unit of electrical charge is the:

- | | |
|-----------|------------|
| a. Volt | c. Joule |
| b. Ampere | d. Coulomb |

Q.3 Current flows in a circuit when:

- | | |
|-----------------------|--|
| a. A switch is opened | c. The switch is either open or closed |
| b. A switch is closed | d. There is no voltage |

Q.4 With Ohm's law, if voltage increases and resistance stays the same:

- | | |
|-----------------------------|-------------------------|
| a. Current remains the same | c. Current increases |
| b. Power decreases | d. Resistance decreases |

Q.5 A transformer transform:

- | | |
|------------|-----------------|
| a. Current | c. Frequency |
| b. Voltage | d. Both A and B |

Q.6 The process of producing electric current through the variable magnetic field is called:

- | | |
|--------------------|------------------------------|
| a. Electrification | c. Electromagnetic induction |
| b. patience | d. Parabolic |

Q.7 The capacity of a battery is expressed in terms of:

- | | |
|-------------------|-----------------------|
| a. Current rating | c. Ampere hour rating |
| b. Voltage rating | d. None of the above |

Q.8 The direction of the arrow represents the direction of When the diode is forward biased?

- a) P-type material
- b) N-type

- c) P-N Junction
- d) Conventional Current flow.



BHARTIYA SKILL DEVELOPMENT UNIVERSITY

Q.9 Which is the most commonly use refrigerant in AC ?

- a. R134a
- b. Water
- c. Alcohol
- d. Ethylene glycol

Q.10. The function of a compressor is:

- a. To compress the water
- b. To compress the refrigerant
- c. To compress the air
- d. None of the above

Section – B

04X04 = 16 Marks

Q.1 What is diode, rectifiers and transistors? explain its function.

Q.2 Explain electromagnetism with neat diagram.

Q.3 What is current and voltage? Write down properties of current and voltage.

Q.4 Draw with neat diagram series and parallel connections of a resistor.

Section – C

04X06 = 24 Marks

Q. 1 Explain construction, and working of lead acid battery.

Q. 2 Write down the four main components used in vehicle AC system also write down the function of each components in brief.

Q. 3 Explain the structure of an atom.

Q.4 There are two resistors R_1 and R_2 having resistance equal to 20Ω and 30Ω respectively are connected in parallel in an electric circuit. If the potential difference/voltage across the electric circuit is 5 V, find the electric current flowing through the circuit and the total resistance of the resistors.

Vishin



School of Automotive Skills
Session: 2021-22 (Summer Semester)
B. Voc. Program, 3rd Semester,
End-Sem. Examination

Course Code: AUT1305

Time: 2 Hours

Course Name: Automotive Electrical & A.C.

Max. Marks: 50

Instruction:

1. Attempt all the questions.
2. Draw neat and clean diagram.

Section – A

10X01 = 10 Marks

1. c
2. b
3. c
4. c
5. b
6. a
7. a
8. b
9. c
10. d

Section – B

04X04 = 16 Marks

1. A diode is a two-terminal electronic component that conducts current primarily in one direction (asymmetric conductance); it has low (ideally zero) resistance in one direction, and high (ideally infinite) resistance in the other.
A rectifier is an electrical device that converts alternating current (AC), which periodically reverses direction, to direct current (DC), which flows in only one direction. The reverse operation is performed by the inverter.
Transformers are electrical devices consisting of two or more coils of wire used to transfer electrical energy by means of a changing magnetic field. Function of a transformer is to transform alternating current energy from one voltage to another voltage.
2. It is a basic law of electromagnetism predicting how a magnetic field will interact with an electric circuit to produce an electromotive force (EMF). This phenomenon is known as electromagnetic induction.



BHARTIYA SKILL DEVELOPMENT UNIVERSITY

An **electric current** is a stream of charged particles, such as electrons or ions, moving through an electrical conductor or space. **Voltage** is the pressure from an electrical circuit's power source that pushes charged electrons (current) through a conducting loop, enabling them to do work such as illuminating a light. Piezoelectric Effect is the ability of certain materials to generate an electric charge in response to applied mechanical stress.

4. Series and Parallel connection

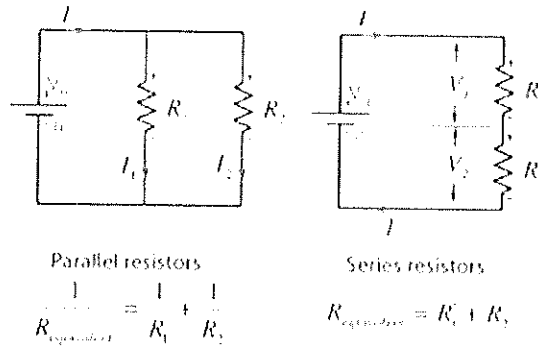

Section – C

04X06 = 24 Marks

- Principal and working: When the sulfuric acid dissolves, its molecules break up into positive hydrogen ions ($2H^+$) and sulphate negative ions (SO_4^-) and move freely. ... The SO_4^- ions being negatively charged moved towards the electrodes connected to the positive terminal of the supply main (i.e., anode).

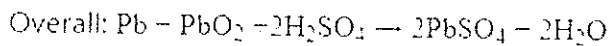
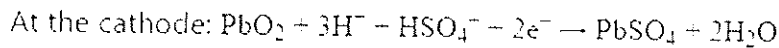
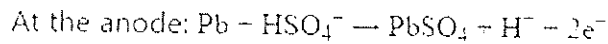

- The four main components of AC is compressor, condenser, evaporator and expansion valve.

- Structure of an atom

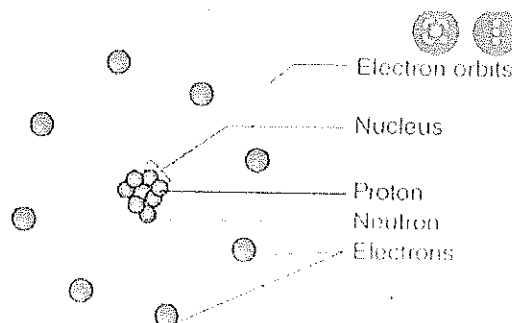



Q4 Resistance numerical

Total resistance (R) = ?

Electric current (I) through the circuit = ?

We know that in parallel combination, the reciprocal of total resistance is,

$$\begin{aligned}\frac{1}{R} &= \frac{1}{R_1} + \frac{1}{R_2} \\ &= \frac{1}{20\Omega} + \frac{1}{30\Omega} \\ &= \frac{3 + 2}{60}\Omega = \frac{5}{60}\Omega\end{aligned}$$

$$\text{Or, } \frac{1}{R} = \frac{1}{12}\Omega$$

Now, electric current through the circuit $I = \frac{V}{R}$

$$\text{Or, } I = 5V \div 12\Omega = 0.416A$$

Thus, total resistance $R = 12\Omega$

Electric current (I) through the circuit = 0.416 A

Vipin

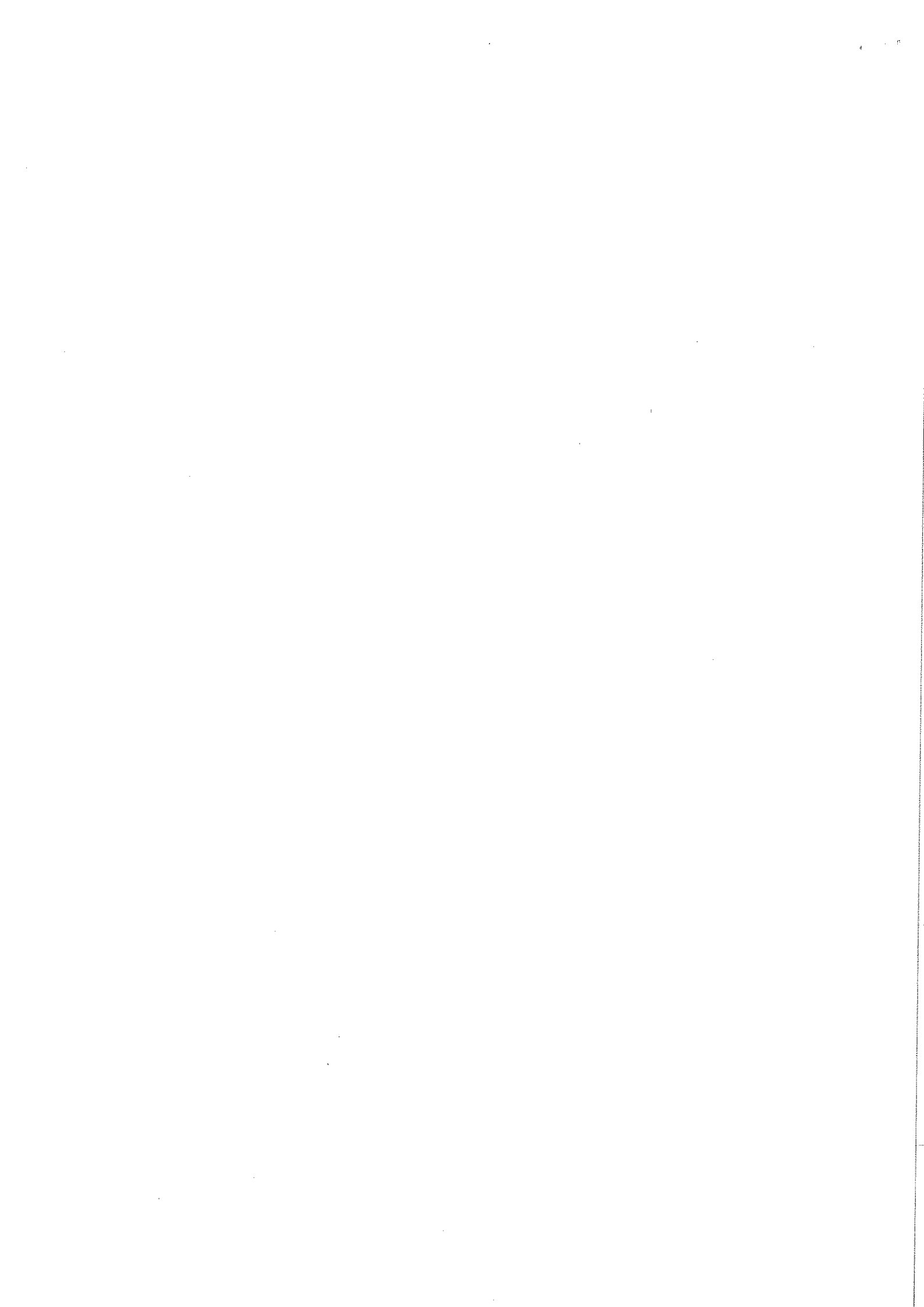



School of Automotive Skills
Session: 2021-22 (Summer Semester)
B. Voc. Program, 3rd Semester,
End-Sem. Examination

Course Code: AUT1305

Time: 2 Hours

Course Name: Automotive Electrical and AC

Max. Marks: 50

Instruction:

1. Answer all questions from section A, each question carries one mark.
2. Answer all questions from section B, each question carries four mark.
3. Answer all questions from section C, each question carries six mark.

Section – A

10X01 = 10 Marks

Q. 1 The process of producing electric current through variable magnetic field is called:

- | | |
|--------------------|------------------------------|
| a. Patience | c. Parabolic |
| b. Electrification | d. Electromagnetic induction |

Q.2 Where is the expansion valve installed in automotive AC system?

- a. at the condenser inlet and outlet tubes
- b. at the evaporator inlet and condenser outlet
- c. between the evaporator outlet and the compressor inlet
- d. between the evaporator outlet and condenser inlet

Q.3 The charge on an electron is equal to:

- | | |
|--|--|
| a. 1.6×10^{-19} C of -ve charge | c. 1.6×10^{-22} C of -ve charge |
| b. 2.6×10^{-19} C of -ve charge | d. 1.6×10^{-23} C of -ve charge |

Q.4 Which of the following statement is always correct?

- a. An atom has equal number of electrons and protons
- b. An atom has equal number of electrons and neutrons
- c. An atom has equal number of protons and neutrons
- d. An atom has equal number of electrons, protons and neutrons

Q.5 Which of the given fuse is bigger.....

- | | |
|-------|-----------------------|
| a. DC | c. DC or AC |
| b. AC | d. AC and DC are same |

Q.6 A relay is used to:

- | | |
|---------------------------------------|--------------------|
| a. Break the fault current | c. Sense the fault |
| b. Sense the fault and direct to trip | d. All of these |

the circuit

Q.7 Basic relay connection requirements is that the relay must operate for

a) load

b) Internal faults.



BHARTIYA SKILL DEVELOPMENT UNIVERSITY

- c. Both a and b
d. None of these
- Q.8 Electronic multimeter measures:
- a. Voltage current and resistance
b. Current and power
c. Voltage and current
d. Energy and power
- Q.9 Which is the most commonly use refrigerant ?
- a. R134a
b. Water
c. Alcohol
d. Ethylene glycol
- Q.10 .An unknown DC voltage is to be measured. Which measuring range in the multimeter will you select first?
- a. 500 V
b. 50 V
c. 5 V
d. 0.5 V

Section – B

04X04 = 16 Marks

- Q.1 What is transformer? Explain its function. Differentiate between step up transformer and step down transformer
- Q.2 Explain faraday law of electromagnetic induction with neat sketch.
- Q.3 Explain function and working of both an alternator and starter motor.
- Q.4 Explain standard operating procedure of using multimeter and a multimeter can measure multiple electrical properties name them.

Section – C

04X06 = 24 Marks

- Q.1 Explain vapor compression refrigeration cycle use in automotive vehicles with neat sketch.
- Q.2 Explain principal of operation, construction and working of lead acid battery use in automotive vehicles.
- Q.3 Write various electrical symbols used in automotive electrical systems.
- Q.4 Explain with neat sketch various components system connecting in automotive vehicles (wiring diagram).

Vijay



School of Automotive Skills

Session: 2021-22 (Summer Semester)

Answer key.

B. Voc. Program, 3rd Semester,

End-Sem. Examination

Course Code: AUT1305

Time: 2 Hours

Course Name: Automotive Electrical & A.C.

Max. Marks: 50

Instruction:

1. Attempt all the questions.
2. Draw neat and clean diagram.

Section – A

10X01 = 10 Marks

1. c
2. b
3. c
4. c
5. b
6. a
7. a
8. b
9. c
10. d

Section – B

04X04 = 16 Marks

1. Transformers are electrical devices consisting of two or more coils of wire used to transfer electrical energy by means of a changing magnetic field. Function of a transformer is to transform alternating current energy from one voltage to another voltage.



BHARTIYA SKILL DEVELOPMENT UNIVERSITY

BASIS FOR COMPARISON	STEP-UP TRANSFORMER	STEP-DOWN TRANSFORMER
Definition	Step-up transformer increase the output voltage.	Step-down transformer reduces the output voltage.
Voltage	Input voltage is low while the output voltage is high.	Input voltage is high while the output voltage is low.
Winding	High voltage winding is the secondary winding.	High voltage winding is the primary winding.
Current	Current is low on the secondary winding.	Current is high on the secondary winding.
Rating of output voltage	11000 volts or above	110v, 24v, 20v, 10v, etc.
Size of the conductor	Primary winding is made up of thick insulated copper wire.	Secondary winding is made up of thick insulated copper wire
Application	Power plant, X-rays	Doorbell, voltage

- It is a basic law of electromagnetism predicting how a magnetic field will interact with an electric circuit to produce an electromotive force (EMF). This phenomenon is known as electromagnetic induction.
- An alternator is an electrical machine. Its function is to charge the battery on a regular basis. However, if the battery is dead, the alternator cannot charge it. It regulates voltage and supplies power used to operate the car. The electricity used by various parts of the car is generated by the alternator; not by the battery which we usually believe.
The starter is an electric motor placed on the side of the engine. Bendix Mechanism is used here. This automatically allows the pinion gear to engage the flywheel of the engine. Starter rotates and starts the engine. The name actually suits best as the starter sounds exactly what it does. It starts the car.
- A multimeter can be measure current, voltage, resistance, capacitance, inductance etc.

Section – C

04X06 = 24 Marks

- VCRS:

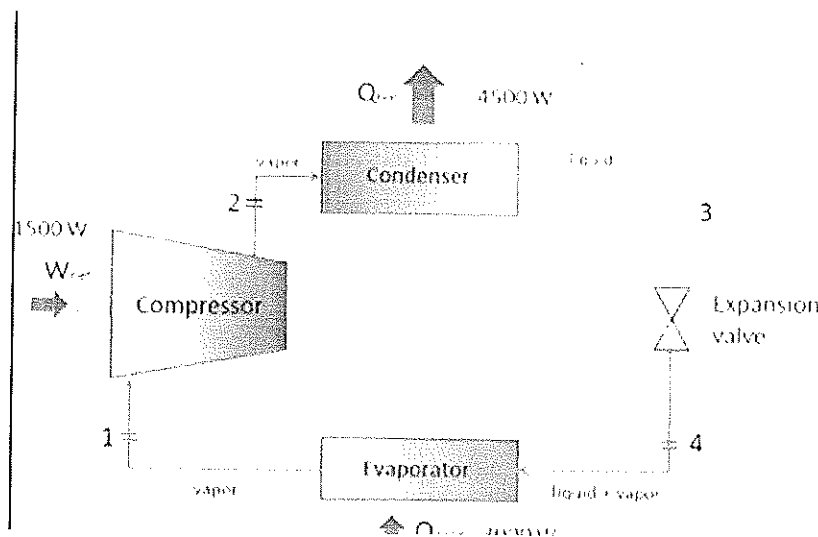







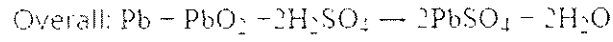
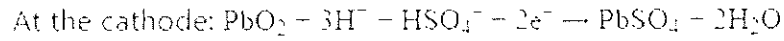
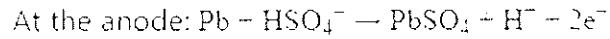



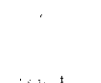

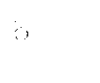

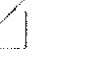

BHARTIYA SKILL DEVELOPMENT UNIVERSITY

2. Principal Construction and working: When the sulfuric acid dissolves, its molecules break up into positive hydrogen ions ($2H^+$) and sulphate negative ions (SO_4^-) and move freely. ... The SO_4^- ions being negatively charged moved towards the electrodes connected to the positive terminal of the supply main (i.e., anode).

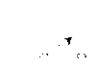

3. Electricals symbols

 RESISTOR	 VARIABLE RESISTOR	 CAPACITOR	 INDUCTOR
 VARIABLE CAPACITOR	 VARIABLE INDUCTOR	 TRANSFORMER	 GENERATOR
 DIODE	 ZENER DIODE	 LED	 MOTOR
 VARIABLE DIODE	 VARIABLE ZENER DIODE	 VARIABLE LED	 VARIABLE MOTOR

4. Wiring diagram:

Vijay

