



Registration No.:

School of Automotive Skills
Session: 2021-22 (Winter Semester)
B. Voc. Program, III Semester,
End-Sem. Examination

Course Code: AUT1301
Course Name: Automotive Power Train

Time: 2 Hours
Max. Marks: 50

Instruction:

1. Answer all questions from section A, each question carries one mark.
2. Answer all question from section B, each question carries four marks.
3. Answer all question from section C, each question carries six marks.

Section – A

10X01 = 10 Marks

Q 1. The reconditioning process used to give cylinder bore surfaces a crosshatch pattern is known as

- A. **Honing**
- B. Porous plating
- C. Boring
- D. Shot peening

Q2. **The petrol engines are also known as**

- A. **Spark ignition (S.I.) engines**
- B. Compression ignition (C.I.) engines
- C. Steam engines
- D. None of these

Q 3. The materials used for cylinder block are

- A. Cast iron and steel
- B. **Cast iron and aluminum alloy**
- C. Steel and aluminum alloy
- D. Brass and steel.

Q4. The condition that results in large quantities of HC emission is

- A High temperature combustion
- B **Incomplete combustion**
- C Low temperature combustion
- D High atmospheric temperature combustion

Q5. The exhaust gas from petrol engine contains

- A Petrol vapours
- B Water vapours
- C Carbon monoxide
- D **All of these**

- Q6. The main function of a resonator is that it
- A Regulates the intake air flow rate
 - B **Reduces the intake air noise**
 - C Enhances intake efficiency
 - D Regulates the intake air temperature
- Q7. The ignition coil is used to
- A. Step up current
 - B. Step down current
 - C. **Step up voltage**
 - D. Step down voltage
- Q8. The self-ignition temperature of Diesel as compared to petrol is
- A. Higher
 - B. **Lower**
 - C. Same
 - D. Depends on fuel quality
- Q9. The main purpose of an engine's air cleaner is that it
- A. Controls the engine's air intake volume
 - B. Reduces the engine's air intake noise
 - C. Prevents rain water from entering the engine
 - D. **Prevents dust and other foreign matter from entering the engine**
- Q10. Which of the following is the main aim of an engine management system to achieve?
- A. high reliability and durability with lowest possible initial cost
 - B. high power output and torque
 - C. **low levels of gaseous and particulate emissions**
 - D. all of the mentioned

Section – B

04X04 = 16 Marks

- Q11. Explain the standard operating procedure of checking piston rings.
- Ans: Following procedure is adopted while checking piston rings
- Push a compression ring down to the bottom of ring travel in the cylinder. Measure the ring end gap. Typical end gap is 0.25 to 0.51mm. If the gap is too small, the ring diameter is too large. A smaller diameter ring set is needed. Some rings can be filed to get the proper end gap. If the end gap is within specification, check the fit of each compression ring in its piston groove. Roll the ring in the groove, if the fit is tight, the groove probably needs cleaning. Check the ring side clearance between ring and groove. Measure the clearance between ring and groove, it should be at least .025mm.

Q12. Explain the working principle of TPS sensor.

Ans: In automobiles, the speed of the engine can be controlled by varying the amount of fuel and air supplied to the engine. For this throttle system is used. Previously, a mechanical linkage was attached to the throttle pedal by which the butterfly valve of the throttle system was controlled. When the driver hits the accelerator cable the valve used to open wide which causes high flow of fuel or air thereby increasing the speed of the vehicle. This sensor is usually mounted on the throttle body. It senses the position of the throttle valve or butterfly valve and transmits the information to the Engine control unit. This sensor monitors how far down the accelerator pedal is pushed and gives the output current determining the position of the pedal. The position of the pedal controls the airflow of the engine. If the valve is wide opened, a large amount of air is supplied to the engine and vice-versa. The output given by this sensor, along with other sensors is transmitted to the engine control unit, which decides the amount of fuel to be injected into the engine accordingly.

This sensor is a three wired potentiometer. Through the first wire, a 5V power is supplied to the sensors resistive layer. The second wire is used as ground whereas the third wire is connected to the potentiometer wiper and provides input to the Engine control system.

Based on its construction, there are three types of throttle position sensors. They are the throttle position sensors with built-in end switches also known as Closed Throttle Position Sensor, the potentiometer type and the combination of both these types.

Q13. What is the function of air induction system?

Ans: Following are the function of air induction system

1. Supply the filter air to combustion chamber
2. Meter the amount of air entering.
3. muffles induction noise

Q14. Explain the working of throttle body.

Ans: The amount of air that enters a spark ignition engine is primarily controlled by the driver moving the accelerator pedal. The foot-operated pedal connects through linkage or cable to the throttle valve in the throttle body. This is air-control device for all spark ignition engines.

Depressing the accelerator pedal opens the throttle valve. This allows fresh air from the air cleaner to enter the intake manifold. The throttle valve controls only air if the engine has port (multipoint) or throttle body injection.

Throttle valve is fitted with following sensors and actuator

MAP Sensor: It is Manifold Absolute pressure sensor, which checks the vacuum pressure developed in the intake and thereby helps in calculating the amount of air entering.

TPS Sensor: Throttle position sensor, which tells exact position of throttle valve in real time

IAC Valve: This is a solenoid-based actuation valve, which provide the path for air during idling.

Section – C

04X06 = 24 Marks

Q15. What are the Major Components of an IC Engine? Explain with their Function

Ans: Following are the main components of IC Engine

1. **Cylinder-block:** The cylinder is the main body of the IC engine. The cylinder is a part in which the intake of fuel, compression of fuel, and burning of fuel take place. The main function of the cylinder is to guide the piston. It is in direct contact with the products of combustion so it must be cooled. For cooling the cylinder, a water jacket (for liquid cooling used in most cars) or fin (for air cooling used in most bikes) are situated on outer side of the cylinder.
2. **Cylinder-head:** The top end of the engine cylinder is closed by means of a removable cylinder head. There are two holes or ports at the cylinder head, one for intake of fuel and the other for exhaust. Both the intake and exhaust ports are closed by the two valves known as the inlet and exhaust valve.
3. **Piston:** A piston is fitted to each cylinder as a face to receive gas pressure and transmit the thrust to the connecting rod. It is a prime mover in the engine. The main function of the piston is to give a tight seal to the cylinder through the bore and slide freely inside the cylinder.
4. **Piston-rings:** To provide a good sealing fit and less friction resistance between the piston and cylinder, pistons are equipped with piston rings. These rings are fitted in grooves that have been cut in the piston.
5. **Connecting-rod:** Connecting rod connects the piston to the crankshaft and transmits the motion and thrust of the piston to the crankshaft. It converts the reciprocating motion of the piston into the rotary motion of the crankshaft.
6. **Crank-shaft:** The crankshaft of an internal combustion engine receives the efforts or thrust supplied by the piston to the connecting rod and converts the reciprocating motion of the piston into the rotary motion of the crankshaft.
7. **Crankcase:** The main body of the engine at which the cylinder is attached and which contains the crankshaft and crankshaft bearing is called the crankcase. It serves as the lubricating system too and sometimes it is called an oil sump. All the oil for lubrication is placed in it.

8. Valves: To control the inlet and exhaust of an internal combustion engine, valves are used. The number of valves in an engine depends on the number of cylinders.

9. Sparkplug: It is used in a spark-ignition engine. The main function of a spark plug is to conduct a high potential from the ignition system into the combustion chamber to ignite the compressed air-fuel mixture. 10. Injector: An injector is usually used in a compression ignition engine. It sprays the fuel into the combustion chamber at the end of the compression stroke. It is fitted on the cylinder head.

10. Camshaft: The camshaft is used in the IC engine to control the opening and closing of valves at proper timing. For proper engine output inlet valve should open at the end of the exhaust stroke and close at the end of the intake stroke.

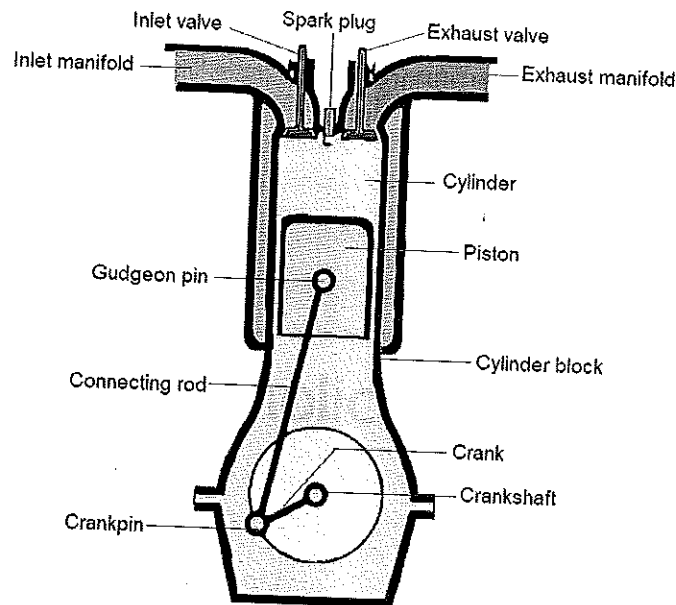

Q16. Explain the various components of Air Induction system.

Ans: Following are the major components of Air Induction System

Air Cleaner: The air cleaner actually contains an air filter which removes solid particles such as dust, pollen, and mold from air that enters the engine. Air enters the engine through the air intake or air induction system. The grit and dust particles in this air must be removed before it enters the engine.

The air cleaner also muffles induction noise.

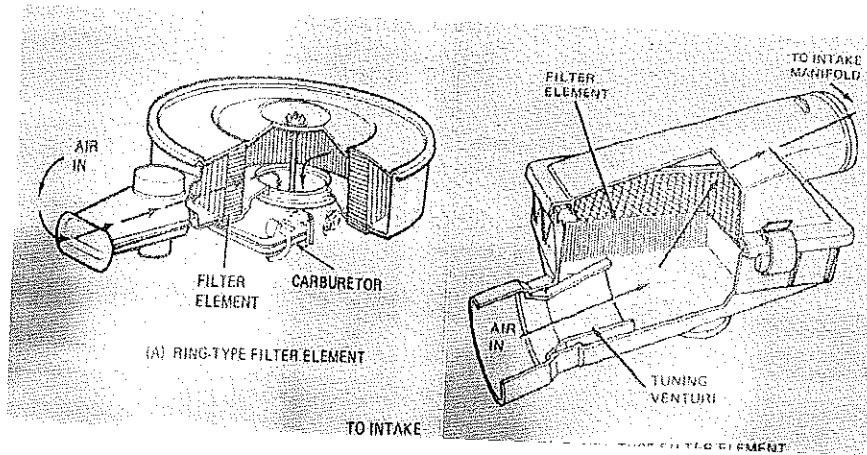

Throttle body: The amount of air that enters a spark ignition engine is primarily controlled by the driver moving the accelerator pedal. The foot-operated pedal connects through linkage or cable to the throttle valve in the throttle body. This is air-control device for all spark ignition engines.

Depressing the accelerator pedal opens the throttle valve. This allows fresh air from the air cleaner to enter the intake manifold. With a carburetor, the throttle valve controls the amount of air-fuel mixtures that enters

The throttle valve controls only air if the engine has port (multipoint) or throttle body injection.

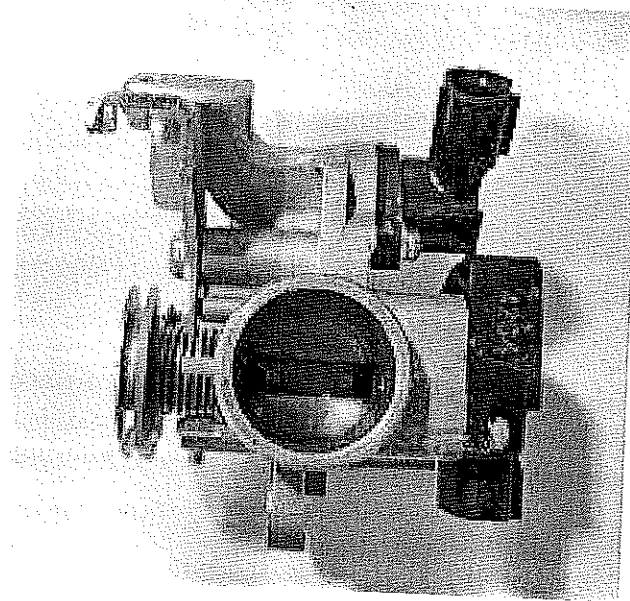

Instead of a mechanically-operated throttle valve, some cars have an electronic throttle control or drive-by-wire system. A sensor on the accelerator pedal signals its position to the electronic control module (ECM). The ECM computes the proper opening of the throttle valves. Signals then are sent to small motors on the throttle body which open and close the throttle valves as required.

Intake Manifold: The primary function of the intake manifold is to evenly distribute the combustion mixture (or just air in a direct injection engine) to each intake port in the cylinder head(s). Even distribution is important to optimize the efficiency and performance of the engine. It may also serve as a mount for the carburetor, throttle

body, fuel injectors and other components of the engine. The Intake manifold connects to the throttle body with the intake ports in the cylinder head.

The manifold has a set of passages or runners through which air or air-fuel mixture flows. With port fuel injection, only air flows through. Fuel is injected into the air as it flows through the intake ports. With a carburetor or throttle body injection, fuel mixed with the air as it enters the intake manifold.

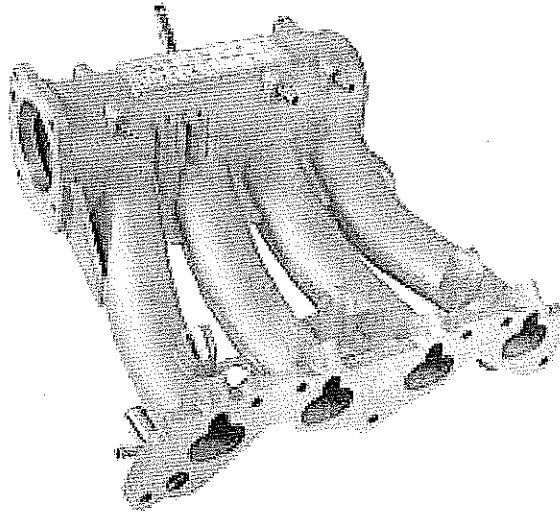

Q17. Explain the Engine management system in detail.

Ans: EMS stands for Engine Management System, consisting of a wide range of electronic and electrical components such as sensors, relays, actuators, and an Engine Control Unit. They work together to provide the Engine Management System with vital data parameters. These are essential for governing various engine functions effectively. Furthermore, modern-day engine technologies incorporate the EMS. These include MPFi & GDi systems in Petrol engines and CRDi systems in diesel engines for improved performance.

ECU stands for Engine Control Unit and ECM for Engine Control Module. Both are the same. However, it is also a generic term for any Electronic Control Unit/Module. The Engine Control Unit is a central part of the Engine Management System, virtually the 'Brain' of the engine. It plays a vital role in collecting, analyzing, processing, and executing the data it receives from various sub-systems. Furthermore, an ECU comprises a computer that uses a microchip to process the inputs from multiple engine sensors in real-time. Furthermore, the Electronic Control Unit contains hardware and software. The ECU's printed circuit board (PCB) consists of a micro-controller chip or the CPU (Central Processing Unit). The micro-controller or chips on the PCB store the software. It is possible to re-program the ECU by updating the software or replacing

chips. All the engine sensors send data inputs through electrical signals to the ECU. In turn, the ECU controls various actuators, ignition timing, variable valve timing, etc. Based on this data input, the ECU precisely calculates and delivers the ideal air-fuel mixture. It also regulates the engine's idle speed and limits the top speed of a vehicle. This system is also widely referred to as an "Electronic Engine Management System" or the EMS. Furthermore, it is possible to customize the modern-day ECUs to suit different vehicular applications and varying customer demands. Also, some cars have an individual "Control Module" for all major systems. For example, a modern car has the following individual Control Modules that control the respective systems. An Engine Control Unit connects to all the individual Electronic Control Modules (ECMs). A modern-day car consists of more than one Control Modules, each exclusive for every primary system, which improves performance. However, the manufacturers seldom refer to these systems as car computers since they are multiple computers instead of one.

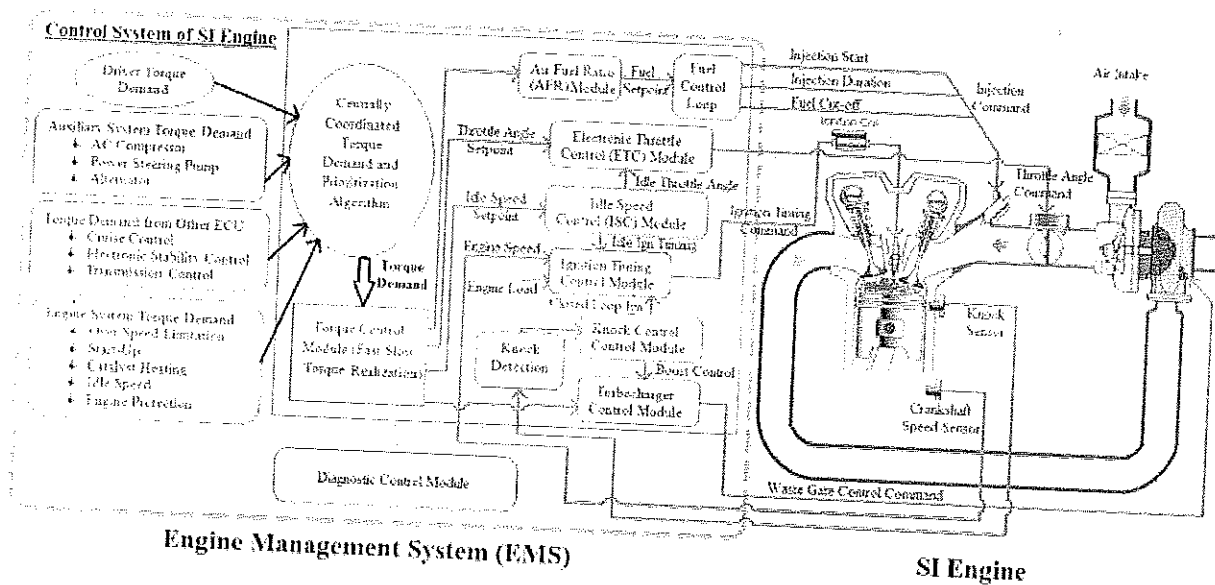

Q18. Draw and explain Exhaust system layout.

Ans: Depending on the overall system design, the exhaust gas may flow through one or more of:

- Cylinder Head and Exhaust Manifold.
- A turbocharger to increase engine power.
- A catalytic converter to reduce air pollution.
- A muffler (North America) / silencer (UK/India), to reduce noise.

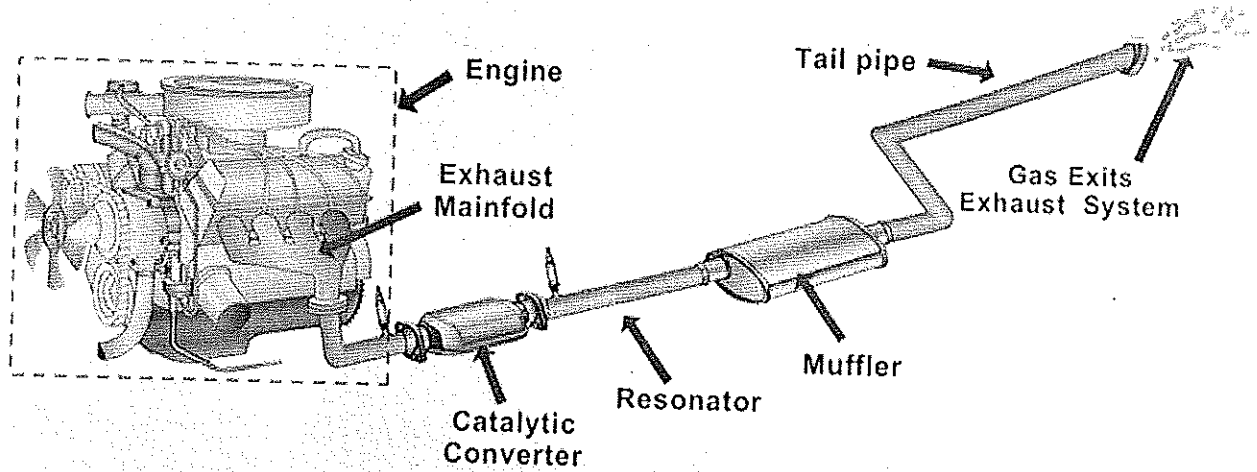

The exhaust system of an automobile consists of an exhaust manifold, catalytic converter, resonator and a muffler connected with a tail pipe

Exhaust Manifold: The exhaust manifold collects the burned gases as they are expelled from the engine cylinders and directs them to the exhaust pipe. The temperature at this area is high. So, a material with suitable thermal expansion coefficient, service temperature, strength, corrosion resistance must be used here. There are two types of manifolds. They are cast iron manifold, sheet metal manifold.

They provide very good strength to withstand manifold from cracking. Low thermal mass and light weight manifolds are required for fast light-off exhaust system applications. The weld ability of the sheet metal manifold is easier. These materials provide sufficient thermal expansion co-efficient, service temperature, strength, thermal and corrosion resistance.

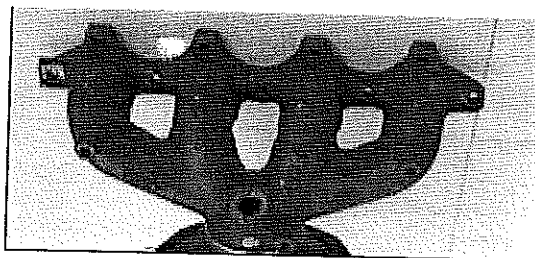

Cast Iron

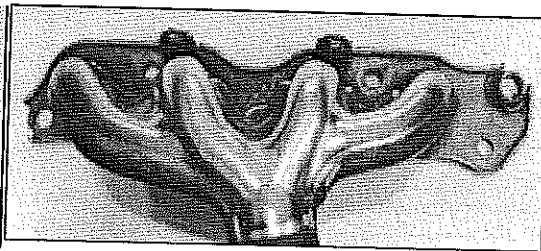

Sheet Metal

Exhaust Pipes: The exhaust pipes are responsible for transporting the burned exhaust gases from the engine and the exhaust manifold and funneling them towards the car's tailpipe. It can be metal or aluminum. The pipes are used to create an effectively sealed pathway.

Catalytic Converter: A catalytic converter is a device that uses a catalyst to convert three harmful compounds in car exhaust into harmless compounds.

HOW A CATALYTIC CONVERTER WORKS

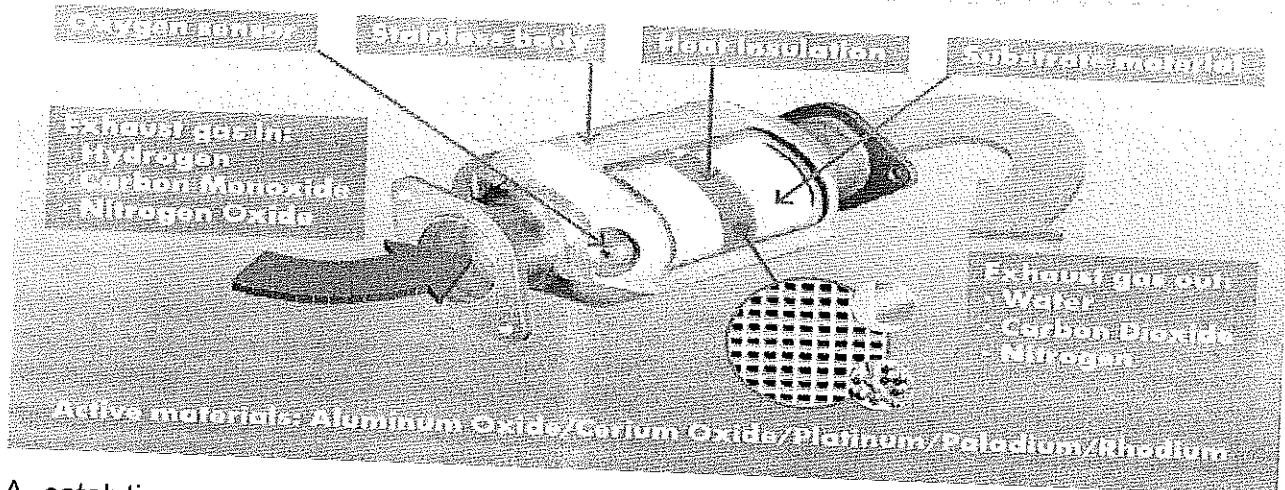

A catalytic converter is a device that uses a catalyst to convert three harmful compounds in car exhaust into harmless compounds. Hydrocarbons - in the form of unburned gasoline. Carbon monoxide - formed by the combustion of gasoline. Nitrogen oxides - created when the heat in the engine forces nitrogen in the air to combine with oxygen.

Muffler: Mufflers are installed on cars and motorcycles to increase airflow out the engine by dissipating exhaust gases. They are also used to suppress exhaust noises by decreasing sound levels emitted by the engine.

Mufflers are installed on cars and motorcycles to increase airflow out the engine by dissipating exhaust gases. They are also used to suppress exhaust noises by decreasing sound levels emitted by the engine.

Tail Pipe: The tail pipe is end of the final length of exhaust pipe which ends with just a straight or angled cut where it vents to open air.

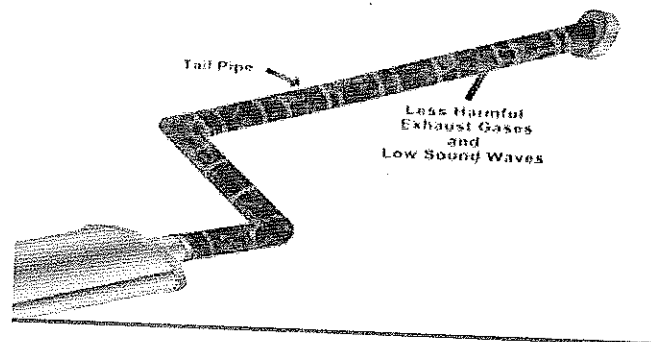



BHARTIYA SKILL DEVELOPMENT UNIVERSITY

Registration No.:

School of Automotive Skills
Session: 2021-22 (Winter Semester)
B. Voc. Program, III Semester,
End-Sem. Examination

Course Code: AUT1301

Time: 2 Hours

Course Name: Automotive Powertrain

Max. Marks: 50

Instruction:

1. Answer all questions from section A, each question carries one mark.
2. Answer all question from section B, each question carries four marks.
3. Answer all question from section C, each question carries six marks.

Section – A

10X01 = 10 Marks

Q1. What are the important parameters in a gasoline engine that can be controlled?

- A. air-fuel ratio
- B. mixture distribution between cylinders
- C. ignition timing
- D. all of the mentioned**

Q2. Diesel engines are also known as

- A. Spark ignition (S.I.) engines
- B. Compression ignition (C.I.) engines**
- C. Steam engines
- D. None of these

Q3. Hall effect pickup use _____

- A. inductive transducers
- B. potentiometers
- C. thermistors
- D. semiconductors**

Q4. Hot-wire sensors are used for the measurement of _____

- A. temperature
- B. pressure
- C. mass flow rate**
- D. smoke intensity



BHARTIYA SKILL DEVELOPMENT UNIVERSITY

- Q5. Catalytic converters use lambda sensors to keep _____
- A. exhaust temperature constant
 - B. exhaust pressure constant
 - C. **excess air ratio within a range**
 - D. flow rate of air constant
- Q6. _____ is the basic requirement of a good combustion chamber.
- A. Low volumetric efficiency
 - B. High compression ratio
 - C. Low compression ratio
 - D. **High power output and high thermal efficiency**
- Q7. The ignition coil is used to
- A. Step up current
 - B. Step down current
 - C. **Step up voltage**
 - D. Step down voltage
- Q8. The self-ignition temperature of petrol as compared to Diesel is
- A. **Higher**
 - B. Lower
 - C. Same
 - D. Depends on fuel quality
- Q9. The main purpose of an engine's air cleaner is that it
- A. Controls the engine's air intake volume
 - B. Reduces the engine's air intake noise
 - C. Prevents rain water from entering the engine
 - D. **Prevents dust and other foreign matter from entering the engine**



BHARTIYA SKILL DEVELOPMENT UNIVERSITY

Q10. Radiator tubes are generally made of _____

- A. cast iron
- B. steel
- C. plastics
- D. **brass**

Section – B

04X04 = 16 Marks

Q11. What are the various components of the Exhaust system of a car?

Ans: Depending on the overall system design, the exhaust gas may flow through one or more of:

- Cylinder Head and Exhaust Manifold.
- A turbocharger to increase engine power.
- A catalytic converter to reduce air pollution.
- A muffler (North America) / silencer (UK/India), to reduce noise.

Exhaust Manifold: The exhaust manifold collects the burned gases as they are expelled from the engine cylinders and directs them to the exhaust pipe. The temperature at this area is high. So, a material with suitable thermal expansion co-efficient, service temperature, strength, corrosion resistance must be used here. There are two types of manifolds. They are cast iron manifold, sheet metal manifold.

Exhaust Pipes: The exhaust pipes are responsible for transporting the burned exhaust gases from the engine and the exhaust manifold and funneling them towards the car's tailpipe. It can be metal or aluminum. The pipes are used to create an effectively sealed pathway.

Catalytic Converter: A catalytic converter is a device that uses a catalyst to convert three harmful compounds in car exhaust into harmless compounds. A catalytic converter is a device that uses a catalyst to convert three harmful compounds in car exhaust into harmless compounds. Hydrocarbons - in the form of unburned gasoline. Carbon monoxide - formed by the combustion of gasoline. Nitrogen oxides - created when the heat in the engine forces nitrogen in the air to combine with oxygen .



BHARTIYA SKILL DEVELOPMENT UNIVERSITY

Muffler: Mufflers are installed on cars and motorcycles to increase airflow out the engine by dissipating exhaust gases. They are also used to suppress exhaust noises by decreasing sound levels emitted by the engine.

Tail Pipe: The tail pipe is end of the final length of exhaust pipe which ends with just a straight or angled cut where it vents to open air.

Q12. Explain the standard operating procedure of checking piston rings.

Ans: Following procedure is adopted while checking piston rings

Push a compression ring down to the bottom of ring travel in the cylinder. Measure the ring end gap. Typical end gap is 0.25 to 0.51mm. If the gap is too small, the ring diameter is too large. A smaller diameter ring set is needed. Some rings can be filed to get the proper end gap. If the end gap is within specification, check the fit of each compression ring in its piston groove. Roll the ring in the groove, if the fit is tight, the groove probably needs cleaning. Check the ring side clearance between ring and groove. Measure the clearance between ring and groove, it should be at least .025mm.

Q13. Enlist the various sensors used in EMS with their function.

Ans: Following table shows the common sensor along with their working principle

Sensor		Principle
1	TPS	Resistive sensors
2	CMP	Hall-effect switch
3	Knock Sensor	Piezoelectric device
4	CKP	Magnetic pulse generators
5	ECT	Thermistor

Q14. Explain the types of Air induction system

Ans: Following type of air induction system is commonly used in ICE

Cold Air Intake Systems: Cold air intake assemblies feature a longer tube with an air filter positioned on the front end. Because this filter is mounted further away from the engine block itself, it can draw air that's actually cooler in temperature. The filter is often positioned near the front corner of the vehicle or even directly behind a bumper or grille. The benefit of drawing in cooler air is that it's denser and packed with more oxygen - allowing more fuel to be burned for increased power. In fact, engineers estimate that every 10-degree F drop in



BHARTIYA SKILL DEVELOPMENT UNIVERSITY

intake air temperature increases power by one percent. It is conventional type of air induction system, which uses small length air pipe and Filter is installed very near to the engine block making air heated up due to the heat of engine itself.

Hot Air Intake system: A heated air inlet or warm air intake is a system commonly used on the original air cleaner assemblies of carbureted engine to increase the temperature of the air going into the engine for the purpose of improving the consistency of the air/fuel mixture to reduce engine emissions and fuel usage

Ram Air Intake system: Another method of channeling cooler air into the engine is the "ram air" intake design. In this setup, a longer tube scoops up air from high-pressure areas at the front of the vehicle. But unlike cold air intakes which have the air filter positioned at the front of the tube, ram air assemblies have air filters mounted in a traditional location back by the engine. Ram air intakes may be equipped with additional pre-filters at the front for protection against splash-up and dust from the road.

Section – C

04X06 = 24 Marks

Q15. Explain the working of the SI Engine with the help of a suitable figure.

ANS: The working of the 4-stroke petrol engine comprises of following 4 important strokes.

1) Suction Stroke:- While suction stroke, the piston moves from TDC to BDC with the intake valve is in open condition and the exhaust valve in closed condition. During this stroke, as the piston moves from TDC to BDC, a partial vacuum is created inside a cylinder that helps to suck (pull) the air-fuel mixture from the intake manifold into the cylinder.

At the end of the suction stroke when the piston reaches the BDC, the inlet valve becomes closed.

2) Compression Stroke: – During the compression stroke, the piston compresses the air-fuel mixture to high pressure inside the cylinder. For this purpose, the piston moves from the BDC towards TDC. During a compression stroke, both valves (Inlet and Exhaust) remain in a closed condition. At the end of the compression stroke, the spark plug produces the spark to ignite the air-fuel mixture.

3) Power Stroke / Expansion Stroke: - It is a stroke, in which power is obtained from the engine by the expansion of combustion products. It is also called an Expansion Stroke because due to the burning of fuel, High-pressure gases expand inside the cylinder and

force the piston downwards. During power stroke piston moves from the TDC towards BDC. At the end of the power stroke, the exhaust port opens.

4) Exhaust Stroke: - In Exhaust stroke, the piston moves from BDC to TDC. During this stroke, burn gases are released to Exhaust Pipe through an exhaust port. The exhaust valve closes when the exhaust stroke is completed.

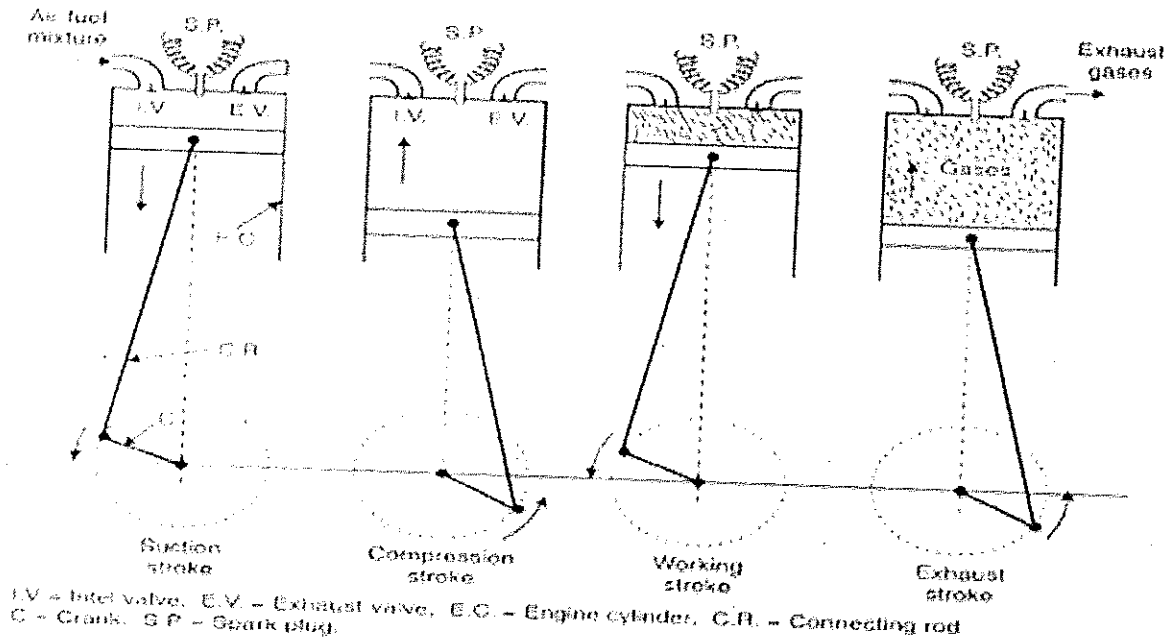

Q16. Explain the working principle of EVAP used in cars.

Ans: Evaporative emissions are raw gasoline vapors that can escape from a vehicle under several different circumstances. Evaporative emissions are in addition to those released from the tail pipe. Gasoline fuel molecules are large and heavy and stay close to the ground. They contribute significantly to urban smog. The whole idea of evaporative emissions controls is to trap these fuel vapors before they can escape to the atmosphere

Working of EVAP

When the engine is shut off, fuel vapors feed on the tank (and float bowl in case of carburetor vehicle) into the charcoal canister.

The activated charcoal in the canister traps or adsorbs the fuel vapors

Later when the engine starts, fresh air flows through the canister and picks up gasoline vapor.

The air then flows into the intake manifold and becomes part of the air-fuel mixture entering the engine cylinders

This action of clearing the trapped fuel vapor from the canister is called purging.

Running the engine removes or purges the vapor from the canister.

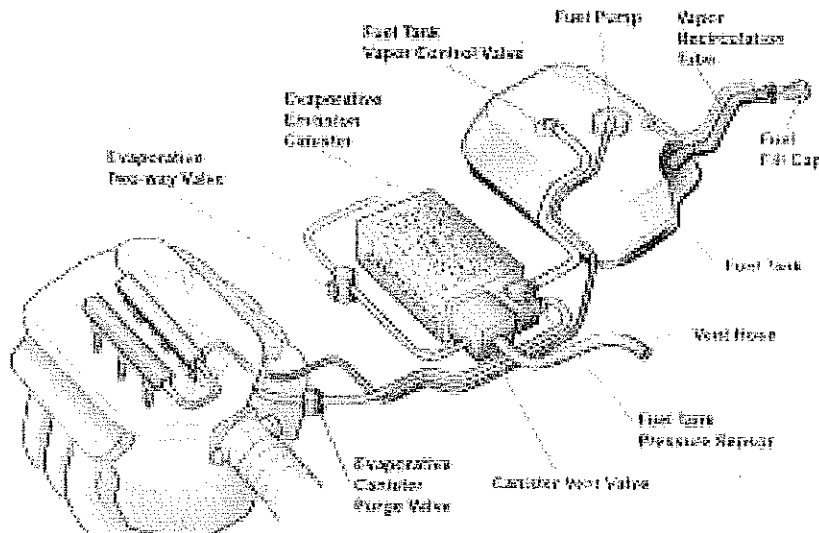

Q17. What are the various control systems used in EMS?

Ans: Any engine for its proper working in all conditions requires control system

The basic parts of the control system are:

- Inputs: These are sensors

The control unit or decision-maker: These are

The driver of the car

The mechanical control

Electronic control module

- Output: These are actuators

The control system has 3 major subsystems:

- **Air Intake system**
- **Fuel delivery system**
- **Electronic control system**

The basic parts of the control system i.e., input sensor, control unit ECM, and output actuators work together in this subsystem to enable the engine to work properly.

Air Intake System: The function of the air intake system is to allow air to reach your car engine. Oxygen in the air is one of the necessary ingredients for the engine



BHARTIYA SKILL DEVELOPMENT UNIVERSITY

combustion process. A good air intake system allows for clean and continuous airflow into the engine, thereby achieving more power and better mileage for your car.

A modern car air intake system has three main parts - the air filter, mass flow sensor, and throttle body. Located directly behind the front grille, the air intake system draws air through a long plastic tube going into the air filter housing, which will be mixed with the car fuel. Only then will the air being sent to the intake manifold that supplies the fuel/air mixture to the engine cylinders.

Fuel delivery system: The fuel delivery system consists of all the components which supply the engine with fuel. This includes the tank itself, all the lines, one or more fuel filters, a fuel pump (mechanical or electric), and the fuel metering components (carburetor or fuel injection system).

It holds the fuel supply and contains a sending unit that tells the fuel gauge how much fuel remains in the tank. The fuel tank also contains a filler tube and, on most fuel-injected vehicles, a fuel pump. In most tanks, there is also a fine mesh screen "sock" attached to the pickup tube. This is used to filter out large particles which could easily clog the fuel lines, fuel pump and fuel filter.

Electronic control system: An **electronic control unit (ECU)** is a small device inside a vehicle that controls one or several electrical systems in that vehicle. It tells electrical systems what to do and how to operate. ECU's core is a microcontroller and it is controlled by embedded software. An electronic control unit receives input from one or several parts of the vehicle and uses that information to take action if needed. For example, an airbag ECU receives information from crash sensors and seat sensors. When there is a crash, the ECU decides which airbags to deploy depending on where passengers are sitting. Then it tells the actuators to deploy them. Then the actuators convert the electrical signal into the physical value needed, using valves, injectors, or relays.

Vehicles may contain over 100 ECUs that in addition to essential functions, like engine performance and power steering, control comfort and security features, such as parking assistance, memory seats and airbag deployment.



BHARTIYA SKILL DEVELOPMENT UNIVERSITY

Q18. Explain the Procedure of the following

- A. Inspection & measurement of engine cylinder bore
- B. Inspection & measurement of piston diameter.

Ans: A. Inspection & measurement of engine cylinder bore

- Check the clearance specifications for the engine you're working with.
- Set a micrometer to the estimated diameter of your engine's cylinders
- Clamp the micrometer into a vice lightly.
- Fit a dial bore gauge with a head that matches the size of the cylinder
- Zero your dial bore gauge to the micrometer
- Insert the dial bore gauge into the first cylinder in the block
- Rock the gauge back and forth until the indicator needle reverses its direction.
- Turn the head of the gauge 90 degrees and measure a second time
- Reset the gauge vertically and lower it by about 1 inch (2.5 cm).

B. Inspection & measurement of piston diameter.

- Pistons should be inspected and measured at several locations including the skirt, top, middle and bottom ring lands and the pin bore.
- The skirt should always be measured exactly 90° from the pin bore.
- The actual height location may vary from manufacturer to manufacturer, but most specify a location the same height as the pin bore location.
- After inspecting the ring lands, check each with a new ring.
- It is important to use new rings for the measuring procedure because wear will reduce the width of the old rings.
- A feeler gauge is placed between the ring and the top of the land.
- Under no circumstances should the ring-to-land clearance exceed .006" (0.15mm). Worn out ring lands do not let the rings seal in the explosive pressures of the burning air-fuel charge.
- It is not advisable to reuse pistons during a rebuild and rings should never be reused.

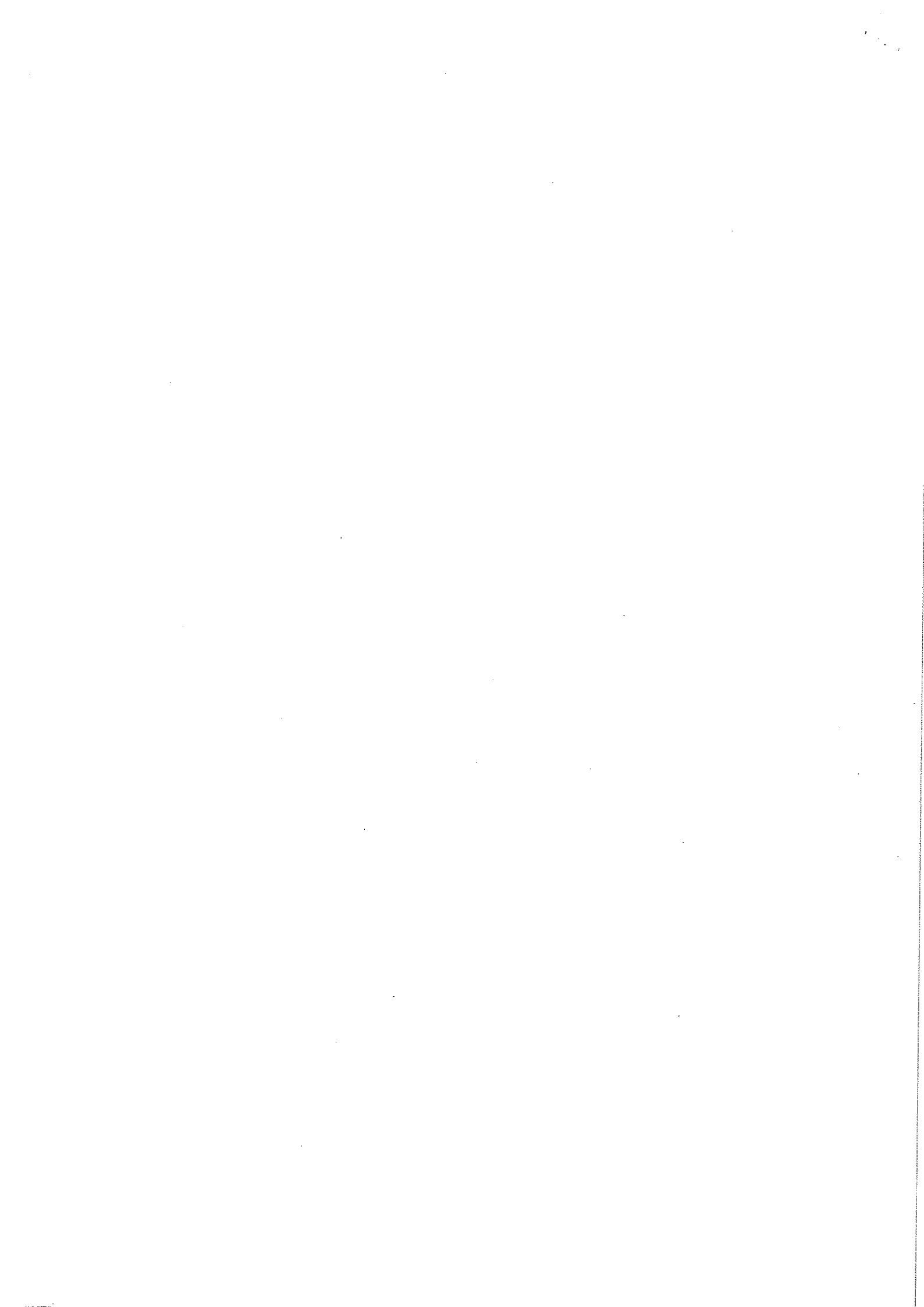



BHARTIYA SKILL DEVELOPMENT UNIVERSITY

Registration No.:

School of Automotive Skills
Session: 2021-22 (Winter Semester)
B. Voc. Program, III Semester,
End-Sem. Examination

Course Code: AUT1301

Time: 2 Hours

Course Name: Automotive Powertrain

Max. Marks: 50

Instruction:

1. Answer all questions from section A, each question carries one mark.
2. Answer all question from section B, each question carries four marks.
3. Answer all question from section C, each question carries six marks.

Section – A

10X01 = 10 Marks

Q 1. The reconditioning process used to give cylinder bore surfaces a crosshatch pattern is known as

- A. Honing
- B. Porous plating
- C. Boring
- D. Shot peening

Q2. The petrol engines are also known as

- A. Spark ignition (S.I.) engines
- B. Compression ignition (C.I.) engines
- C. Steam engines
- D. None of these

Q 3. The materials used for cylinder block are

- A. Cast iron and steel
- B. Cast iron and aluminum alloy
- C. Steel and aluminum alloy
- D. Brass and steel.

Q4. The condition that results in large quantities of HC emission is

- A High temperature combustion
- B Incomplete combustion
- C Low temperature combustion
- D High atmospheric temperature combustion

Q5. The exhaust gas from petrol engine contains

- A Petrol vapours
- B Water vapours
- C Carbon monoxide
- D All of these

Q6. The main function of a resonator is that it

- A Regulates the intake air flow rate
- B Reduces the intake air noise
- C Enhances intake efficiency
- D Regulates the intake air temperature



BHARTIYA SKILL DEVELOPMENT UNIVERSITY

- Q7. The ignition coil is used to
- A. Step up current
 - B. Step down current
 - C. Step up voltage
 - D. Step down voltage
- Q8. The self-ignition temperature of Diesel as compared to petrol is
- A. Higher
 - B. Lower
 - C. Same
 - D. Depends on fuel quality
- Q9. The main purpose of an engine's air cleaner is that it
- A. Controls the engine's air intake volume
 - B. Reduces the engine's air intake noise
 - C. Prevents rain water from entering the engine
 - D. Prevents dust and other foreign matter from entering the engine
- Q10. Which of the following is the main aim of an engine management system to achieve?
- A. high reliability and durability with lowest possible initial cost
 - B. high power output and torque
 - C. low levels of gaseous and particulate emissions
 - D. all of the mentioned

Section – B

04X04 = 16 Marks

- Q11. Explain the standard operating procedure of checking piston rings.
- Q12. Explain the working principle of TPS sensor.
- Q13. What is the function of air induction system?
- Q14. Explain the working of throttle body.

Section – C

04X06 = 24 Marks

- Q15. What are the Major Components of an IC Engine? Explain with their Function
- Q16. Explain the various components of Air Induction system.
- Q17. Explain the Engine management system in detail.
- Q18. Draw and explain Exhaust system layout.



BHARTIYA SKILL DEVELOPMENT UNIVERSITY

Registration No.:

School of Automotive Skills
Session: 2021-22 (Winter Semester)
B. Voc. Program, III Semester,
End-Sem. Examination

Course Code: AUT1301

Time: 2 Hours

Course Name: Automotive Powertrain

Max. Marks: 50

Instruction:

1. Answer all questions from section A, each question carries one mark.
2. Answer all question from section B, each question carries four marks.
3. Answer all question from section C, each question carries six marks.

Section – A

10X01 = 10 Marks

- Q1. What are the important parameters in a gasoline engine that can be controlled?
- A. air-fuel ratio
 - B. mixture distribution between cylinders
 - C. ignition timing
 - D. all of the mentioned
- Q2. Diesel engines are also known as
- A. Spark ignition (S.I.) engines
 - B. Compression ignition (C.I.) engines
 - C. Steam engines
 - D. None of these
- Q3. Hall effect pickup use _____
- A. inductive transducers
 - B. potentiometers
 - C. thermistors
 - D. semiconductors
- Q4. Hot-wire sensors are used for the measurement of _____
- A. temperature
 - B. pressure
 - C. mass flow rate
 - D. smoke intensity
- Q5. Catalytic converters use lambda sensors to keep _____
- A. exhaust temperature constant
 - B. exhaust pressure constant
 - C. excess air ratio within a range
 - D. flow rate of air constant
- Q6. _____ is the basic requirement of a good combustion chamber.
- A. Low volumetric efficiency
 - B. High compression ratio
 - C. Low compression ratio
 - D. High power output and high thermal efficiency



BHARTIYA SKILL DEVELOPMENT UNIVERSITY

- Q7. The ignition coil is used to
- A. Step up current
 - B. Step down current
 - C. Step up voltage
 - D. Step down voltage
- Q8. The self-ignition temperature of petrol as compared to Diesel is
- A. Higher
 - B. Lower
 - C. Same
 - D. Depends on fuel quality
- Q9. The main purpose of an engine's air cleaner is that it
- A. Controls the engine's air intake volume
 - B. Reduces the engine's air intake noise
 - C. Prevents rain water from entering the engine
 - D. Prevents dust and other foreign matter from entering the engine
- Q10. Radiator tubes are generally made of _____
- A. cast iron
 - B. steel
 - C. plastics
 - D. brass

Section – B

04X04 = 16 Marks

- Q11. What are the various components of the Exhaust system of a car?
- Q12. Explain the standard operating procedure of checking piston rings.
- Q13. Enlist the various sensors used in EMS with their function.
- Q14. Explain the types of Air induction system

Section – C

04X06 = 24 Marks

- Q15. Explain the working of the SI Engine with the help of a suitable figure.
- Q16. Explain the working principle of EVAP used in cars.
- Q17. What are the various control systems used in EMS?
- Q18. Explain the Procedure of the following
- A. Inspection & measurement of engine cylinder bore
 - B. Inspection & measurement of piston diameter.



CEP - SOTA

Registration No.:

BHARTIYA SKILL DEVELOPMENT UNIVERSITY

School of Automotive Skills
Session: 2021-22 (Winter Semester)
B. Voc. Program, 3rd Semester,
End Sem. Examination

Course Code: AUT 1302

Time: 2 Hour

Course Name: Automotive Braking, Suspension
and Steering System

Max. Marks: 50

Instruction:

1. All the questions are compulsory to attend.
2. Students are not allowed to bring any smart device or cell phone in the exam hall.
3. Marks will be deducted if any overwriting in words will be found.

Section – A

10X01 = 10 Marks

1. What is TWI stands for?
 - a) Tire wear indicator
 - b) Tread value indicator
 - c) Tread wear indicator
 - d) None of the above
2. Which one of the following sensors in the electronic steering system is used to change the output to the steering motor as per real-time conditions?
 - a) Steering angle sensor
 - b) Torque sensor
 - c) Vehicle speed sensor
 - d) All of the mentioned
3. What is the full form of ESP system?
 - a) Electronic Stability Program
 - b) Engine Stability Program
 - c) Electronic Steering Program
 - d) None of above



BHARTIYA SKILL DEVELOPMENT UNIVERSITY

4. Which one of these is not part of the hydraulic steering system?
 - a) Hydraulic Pump
 - b) Electric Motor
 - c) Steering wheel
 - d) Rack and pinion

5. The wishbone suspension system is a type of.....
 - a) Independent suspension system
 - b) Dependent suspension system
 - c) Rigid suspension system
 - d) None of these

6. What is CV joint stand for?
 - a) Continuous velocity joint
 - b) Constant velocity joint
 - c) Constant variable joint
 - d) None of the above

7. The type of axle which is not being used to transmit power is.....
 - a) Dead axle
 - b) Live axle
 - c) both (a) & (b)
 - d) None of the above

8. Which type of suspension system is used in the VW Polo?
 - a) Macpherson strut system
 - b) Wish Bone system
 - c) Rigid suspension system
 - d) None of the above

9. If a person turns the steering wheel 450 degrees then how much should the wheel turns while having a steering ratio of 40:4?
 - a) 11 degrees
 - b) 120 degrees
 - c) 45 degrees
 - d) None of the above

10. What is the approximate temperature during the Hot Re-treading process?
 - a) 65 degrees Celsius
 - b) 27 degrees Celsius
 - c) 150 degrees Celsius
 - d) None of the above

Section – B

04X04 = 16 Marks

11. Explain the process of tire patch repair.
12. What are the functions of Independent suspension system?
13. Explain the types of CV joints in drive shaft?
14. Suppose a vehicle is having a problem of "Noise while braking", write the process of diagnose and repair according to you.



Registration No.:

BHARTIYA SKILL DEVELOPMENT UNIVERSITY

Section – C

04X06 = 24 Marks

15. Write down the process of front coil spring replacement of Honda city?
16. What is a drive axle? Also, explain the all types of rear axle.
17. Write down the process of overhauling of electrical steering system?
18. Explain the working of ABS system.

[Handwritten signature]

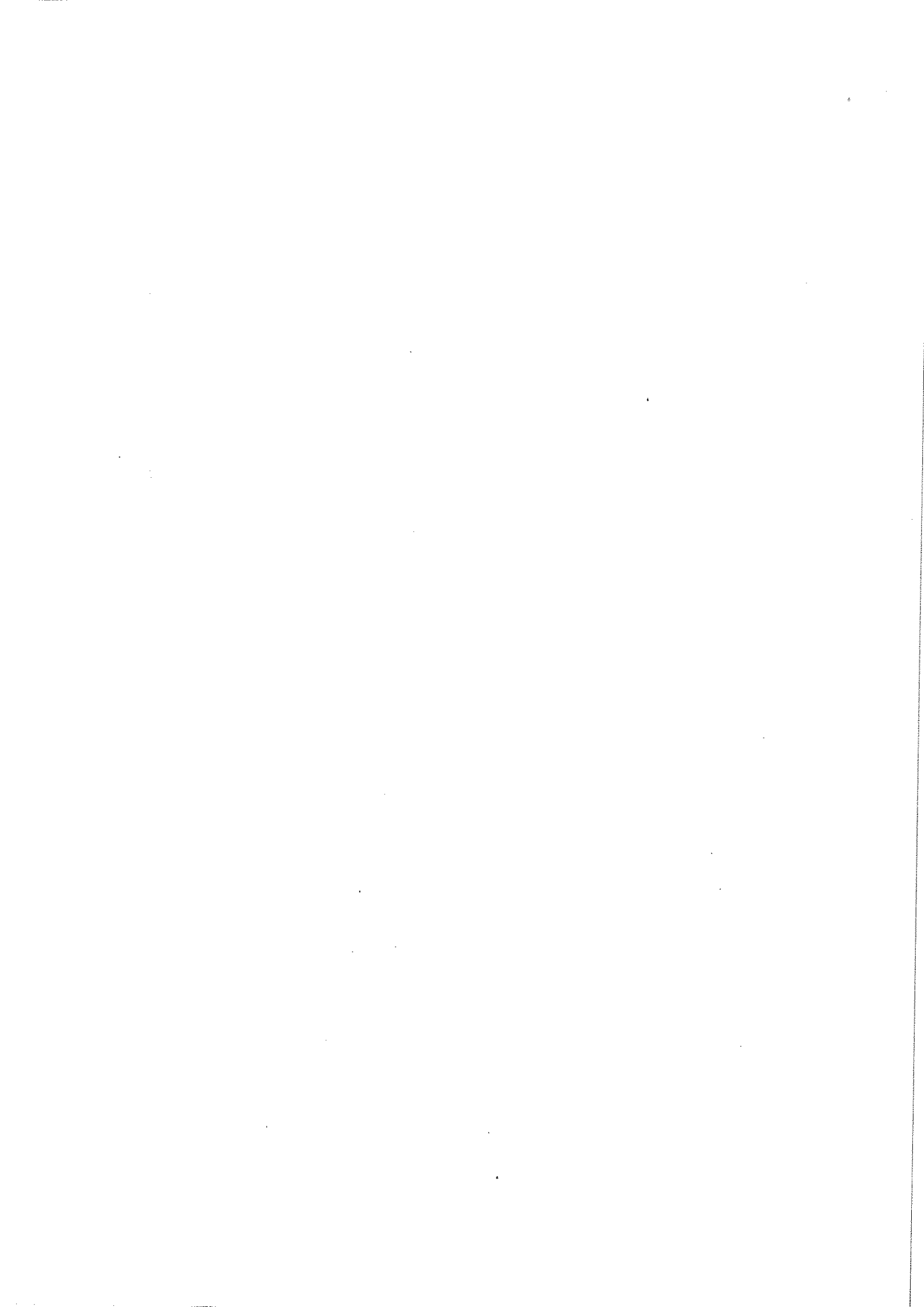



A.K. Set A

Registration No.:

BHARTIYA SKILL DEVELOPMENT UNIVERSITY

School of Automotive Skills
Session: 2021-22 (Winter Semester)
B. Voc. Program, 3rd Semester,
End Sem. Examination

Course Code: AUT 1302

Time: 2 Hour

Course Name: Automotive Braking, Suspension
and Steering System

Max. Marks: 50

Instruction:

1. All the questions are compulsory to attend.
2. Students are not allowed to bring any smart device or cell phone in the exam hall.
3. Marks will be deducted if any overwriting in words will be found.

Section – A

10X01 = 10 Marks

1. What is TWI stands for?

a) Tire wear indicator

b) Tread value indicator

c) Tread wear indicator

d) None of the above

2. Which one of the following sensors in the electronic steering system is used to change the output to the steering motor as per real-time conditions?

a) Steering angle sensor

b) Torque sensor

c) Vehicle speed sensor

d) All of the mentioned

3. What is the full form of ESP system?

a) Electronic Stability Program

b) Engine Stability Program

c) Electronic Steering Program

d) None of above



BHARTIYA SKILL DEVELOPMENT UNIVERSITY

4. Which one of these is not the part of the hydraulic steering system?
a) Hydraulic Pump
b) **Electric Motor**
c) Steering wheel
d) Rack and pinion
5. The wishbone suspension system is type of.....
a) **Independent suspension system**
b) Dependent suspension system
c) Rigid suspension system
d) None of these
6. What is CV joint stand for?
a) Continuous velocity joint
b) **Constant velocity joint**
c) Constant variable joint
d) None of the above
7. The type of axle which is not being used to transmit power is.....
a) **Dead axle**
b) Live axle
c) both (a) & (b)
d) None of the above
8. Which type of suspension system is used in the VW Polo?
a) **Macpherson strut system**
b) Wish Bone system
c) Rigid suspension system
d) None of the above
9. If a person turns the steering wheel 450 degrees then how much should the wheel turns while having a steering ratio of 40:4?
a) 11 degrees
b) 120 degrees
c) **45 degrees**
d) None of the above
10. What is the approximate temperature during the Hot Re-treading process?
a) 65 degrees Celsius
b) 27 degrees Celsius
c) **150 degrees Celsius**
d) None of the above

Section – B

04X04 = 16 Marks

11. Explain the process of tire patch repair.

1. Ans. Patch Installation:

Step 1: Remove Wheel



BHARTIYA SKILL DEVELOPMENT UNIVERSITY

Jack the car and remove the wheel from the hub. Inflate the tire to at least 30 PSI to easily locate the hole. This is manifested by a hissing sound as a result of escaping air. If the hole can't be located, get a small bucket of soapy water and sponge. Dip the sponge in the mixture and squeeze onto the tire. If you see bubbles on the surface, then you've found the hole.

Step 2: Mark the Hole

Use a piece of chalk to mark a small "X" where the hole is located. If a nail or screw is present, resist the urge to pull the nail or any protruding part on the tire surface.

Step 3: Remove Tire from Rim

Remove the tire valve core to release all the air from the tire. Place the wheel in the tire mounting machine and dismount the tire from the rim.

Step 4: Inspect Tire

Check the inside of the tire. Now is the time to remove the nail or foreign object that penetrated the tire. Use long nosed pliers to pull the nail from the outside of the tire. Do this carefully.

Step 5: Buffing the Hole

Apply a light coat of tire cleaner and let it dry. Get the tire buffer and work around the hole. A light buff is enough.

Step 6: Apply Vulcanizing Liquid

Apply a coat of tire vulcanizing liquid around the buffed area. A half inch circumference around the hole is ideal. Let the liquid dry for 10 to 15 seconds.

Step 7: Patch Hole

Get the tire patch and cut to the proper size when necessary. Remove the top and bottom sticker from the patch and place on top of the buffed surface and press firmly. Use a tire patch rolling tool to roll over the tire patch. This will completely seal the patch to the tire.



BHARTIYA SKILL DEVELOPMENT UNIVERSITY

Step 8: Mount Tire

Let the patch dry for at least five minutes before mounting the tire on the rim. Put the tire valve core in the tire valve and pump with the recommended air pressure. A 30 to 35 PSI tire pressure is enough for most street tires.

Step 9: Check Tire

Check the tire first before placing it back in the wheel hub. Check the location of the hole to make sure that no leak is present.

12. What are the functions of the Independent suspension system?

- Maintain correct vehicle ride height.
- Reduce the effect of shock forces.
- Maintain correct wheel alignment.
- Support vehicle weight.
- Keep the tyres in contact with the road.
- Control the vehicle's direction of travel.

13. Explain the types of CV joints in drive shaft?

- Rzeppa CV Joint.
- Fixed and Plunge Joints.
- Plunge Joints (Tripod & Ball-Type)
- Tripod Joints.
- Tripod Joints (Fixed)

14. Suppose a vehicle is having a problem of "Noise while braking", write the process of diagnose and repair according to you.

Ans. **STEP 1** Verify the customer complaint. For example, common drum brake concerns include:

- Low brake pedal
- Parking brake does not hold the vehicle on a hill
- Noise while braking
- Noise when the vehicle is moving, but the brakes are not applied.



BHARTIYA SKILL DEVELOPMENT UNIVERSITY

STEP 2 Perform a visual inspection of the brakes and related parts, such as the wheels, tires, and suspension system.

STEP 3 Determine the root cause. For example, this could include determining that the parking brake linkage is corroded causing the brake shoes to wear. Replacing just the brake shoes will not correct the root cause.

STEP 4 Restore the brake system to like-new operation, which is the purpose of any repair.

STEP 5 Test-drive the vehicle to verify that the service has corrected the customer's complaint.

Section – C

04X06 = 24 Marks

15. Write down the process of front coil spring replacement of Honda city?

Ans.

The following steps are of coil spring replacement:

1. Removal of wheel
2. Remove shock absorber mounting bolts
3. Hold wheel knuckle using rope/cloth.
4. Compression of coil spring.
5. Removal of coil spring
6. Checking of travel of the shock absorber

Reverse the process for assembly

16. What is a drive axle? Also, explain all types of rear axle.

- Ans. **DRIVE AXLE SHAFTS:** Unequal-length drive axle shafts (also called half shafts) result in unequal drive axle shaft angles to the front drive wheels. This unequal angle often results in a pull on the steering wheel during acceleration. This pulling to one side during acceleration due to unequal engine torque being applied to the front drive wheels is called torque steer. To help reduce the effect of torque steer, some vehicles are manufactured with an intermediate shaft that results in equal drive axle shaft angles.

17. Write down the process of overhauling of electrical steering system?

Ans. The following process is for overhauling of electrical steering system:

1. Removal of steering from vehicle.
2. Removal of steering sensor from body.
3. Removal of steering motor.



BHARTIYA SKILL DEVELOPMENT UNIVERSITY

4. Removal of steering motor gear.
5. Removal of tie rod from both side.
6. Removal of rack from column.
7. Reversing the process for assembly.

18. Explain the working of the ABS system.

Ans. Anti-lock Braking System also known as anti-skid braking system (ABS) is an automobile safety system which prevents the locking of wheels during braking and avoid uncontrolled skidding. The modern abs system allows steering during braking which gives more control over the vehicle in case of sudden braking. The main advantages of using ABS system in vehicle is that it provides better control over the vehicle and decreases stopping distance on dry and slippery surfaces. Since in ABS installed vehicle the chance of skidding is very less and hence it provides a better steering control during braking. Without ABS system, even a professional driver can fail to prevent the skidding of the vehicle on dry and slippery surfaces during sudden braking. But with ABS system, a normal person can easily prevent the skidding of the vehicle and get better steering control during braking.



OP Set - B

Registration No.:

BHARTIYA SKILL DEVELOPMENT UNIVERSITY

School of Automotive Skills
Session: 2021-22 (Winter Semester)
B. Voc. Program, 3rd Semester,
End Sem. Examination

Course Code: AUT 1302

Time: 2 Hour

Course Name: Automotive Braking, Suspension
and Steering System

Max. Marks: 50

Instruction:

1. All the questions are compulsory to attend.
2. Students are not allowed to bring any smart device or cell phone to the exam hall.
3. Marks will be deducted if any overwriting in words will be found.

Section – A

10X01 = 10 Marks

1. Which of the following steering system works on the turning and sliding mechanism?
 - a) Ackermann
 - b) a & b
 - c) Davis
 - d) None of the above
2. Which of these were or are being used in automobiles to provide suspension
 - a) Leaf springs
 - b) Coil springs
 - c) Torsion bars
 - d) All of the mentioned
3. What is the full form of the ESP system?
 - a) Electronic Stability Program
 - b) Engine Stability Program
 - c) Electronic Steering Program
 - d) None of above



BHARTIYA SKILL DEVELOPMENT UNIVERSITY

4. Which one of these is not part of the electric steering system?
 - a) Hydraulic Pump
 - b) Electric Motor
 - c) Steering wheel
 - d) Rack and pinion
5. What is the Macpherson strut system?
 - a) Steering system
 - b) Suspension system
 - c) Braking system
 - d) None of these
6. Which part of an automobile is the first suspension for the vehicle?
 - a) Leaves of leaf spring
 - b) Coil Spring
 - c) Tires
 - d) None of the above
7. The type of axle which is used to transmit power is.....
 - a) Dead axle
 - b) Live axle
 - c) both (a) & (b)
 - d) None of the above
8. Which type of suspension system is used in the Honda City?
 - a) Macpherson strut system
 - b) Wish-Bone system
 - c) Rigid suspension system
 - d) None of the above
9. If a person turns the steering wheel 220 degrees then how much should the wheel turn while having a steering ratio of 20:2?
 - a) 11 degrees
 - b) 120 degrees
 - c) 22 degrees
 - d) None of the above
10. Which material is used to manufacture the backing plate in the braking system?
 - a) Mild Steel
 - b) Spring Steel
 - c) Stamped Steel
 - d) High Carbon Steel

Section – B

04X04 = 16 Marks

11. Explain hill climb assist system technology.
12. What are the purposes of a rigid suspension system?
13. Write down the process and advantages of tire rotation
14. Suppose a vehicle is having a problem with "Steering Pull", write the process of diagnosis and repair according to you.



Registration No.:

BHARTIYA SKILL DEVELOPMENT UNIVERSITY

Section – C

04X06 = 24 Marks

15. Write down the process of suspension frame replacement of Honda city?
16. What is Re-treading? Explain the cold Re-treading process.
17. Write down the process of drive axle replacement?
18. Explain the components of Hydraulic electric steering system mechanism.





Set - B A.V.

Registration No.:

BHARTIYA SKILL DEVELOPMENT UNIVERSITY

School of Automotive Skills
Session: 2021-22 (Winter Semester)
B. Voc. Program, 3rd Semester,
End Sem. Examination

Course Code: AUT 1302

Time: 2 Hour

Course Name: Automotive Braking, Suspension
and Steering System

Max. Marks: 50

Instruction:

1. All the questions are compulsory to attend.
2. Students are not allowed to bring any smart device or cell phone to the exam hall.
3. Marks will be deducted if any overwriting in words will be found.

Section – A

10X01 = 10 Marks

1. Which of the following steering system works on the turning and sliding mechanism?

a) Ackermann

b) a & b

c) Davis

d) None of the above

2. Which of these were or are being used in automobiles to provide suspension

a) Leaf springs

b) Coil springs

c) Torsion bars

d) All of the mentioned

3. What is the full form of the ESP system?

a) Electronic Stability Program

b) Engine Stability Program

c) Electronic Steering Program

d) None of above



BHARTIYA SKILL DEVELOPMENT UNIVERSITY

4. Which one of these is not part of the electric steering system?
- a) Hydraulic Pump
b) **Electric Motor**
c) Steering wheel
d) Rack and pinion
5. What is the Macpherson strut system?
- a) Steering system
b) **Suspension system**
c) Braking system
d) None of these
6. Which part of an automobile is the first suspension for the vehicle?
- a) Leaves of leaf spring
b) Coil Spring
c) **Tires**
d) None of the above
7. The type of axle which is used to transmit power is.....
- a) Dead axle
b) **Live axle**
c) both (a) & (b)
d) None of the above
8. Which type of suspension system is used in the Honda City?
- a) Macpherson strut system
b) Wish-Bone system
c) Rigid suspension system
d) None of the above
9. If a person turns the steering wheel 220 degrees then how much should the wheel turn while having a steering ratio of 20:2?
- a) 11 degrees
b) 120 degrees
c) **22 degrees**
d) None of the above
10. Which material is used to manufacture the backing plate in the braking system?
- a) Mild Steel
b) Spring Steel
c) **Stamped Steel**
d) High Carbon Steel

Section – B

04X04 = 16 Marks

11. Explain hill climb assist system technology.

Ans.

Sensors in the vehicle are used to detect when a vehicle is on an incline. The hill start assist maintains the brake pressure for a set period of time as you switch from the brakes to the gas pedal. Once you press the accelerator, it releases the brake.



BHARTIYA SKILL DEVELOPMENT UNIVERSITY

12. What are the purposes of a rigid suspension system?

Ans.

1. Reduction of un-sprung weight i.e. the weight of the wheels and other components receiving the road shocks.
2. Reduction of rolling or pitching of the body to a minimum with appropriate design and attachment of springs.
3. To absorb satisfactorily small as well as large road impacts with the help of the single springing device.

13. Write down the process and advantages of a tire rotation?

Ans. Tire rotation spreads wear evenly among tires, which in turn evens tread life. This results in a uniform tread depth on all 4 tires. Better tread wear and tread depth improve overall vehicle performance, including braking and cornering. Even wearing of tires is important for balanced vehicle handling.

14. Suppose a vehicle is having a problem with "Steering Pull", write the process of diagnosis and repair according to you.

Ans. **STEP 1** Verify the customer complaint. For example, common drum brake concerns include:

- Low brake pedal
- Parking brake does not hold the vehicle on a hill
- Noise while braking
- Noise when the vehicle is moving, but the brakes are not applied.

STEP 2 Perform a visual inspection of the brakes and related parts, such as the wheels, tires, and suspension system.

STEP 3 Determine the root cause. For example, this could include determining that the parking brake linkage is corroded causing the brake shoes to wear. Replacing just the brake shoes will not correct the root cause.

STEP 4 Restore the brake system to like-new operation, which is the purpose of any repair.

STEP 5 Test-drive the vehicle to verify that the service has corrected the customer's complaint.



BHARTIYA SKILL DEVELOPMENT UNIVERSITY

Section – C

04X06 = 24 Marks

15. Write down the process of suspension frame replacement of Honda city?

Ans. The following steps are of suspension frame replacement:

1. Removal of wheel
2. Remove shock absorber mounting bolts
3. Removal of suspension frame
4. Removal of balancing rod
5. Removal of steering mounting
6. Removal of frame
7. Reverse the process for assembly.

16. What is Re-treading? Explain the cold Re-treading process.

Ans. Retreading is a process through which we can use our old tyres. In this method, a worn casing of a tyre that has a good structural quality is taken off and put through a process in which it gets a completely renewed tread and sidewall rubber. After that, the revamped tyre is taken forward for a curing process in which the new rubber is vulcanized to the original casing and hence, the tyre gets a newly made tread pattern.

17. Write down the process of drive axle replacement?

Ans. The following is the process for drive axle replacement:

1. Remove the wheel
2. Remove the hub bolt
3. Remove the shocker hub bolt
4. Remove the wheel hub from suspension arm
5. Adjust the wheel hub side to side
6. Remove the drive axle shaft
7. Reverse the process for assembly

18. Explain the components of Hydraulic electric steering system mechanism.

Ans.

BHARTIYA SKILL DEVELOPMENT UNIVERSITY

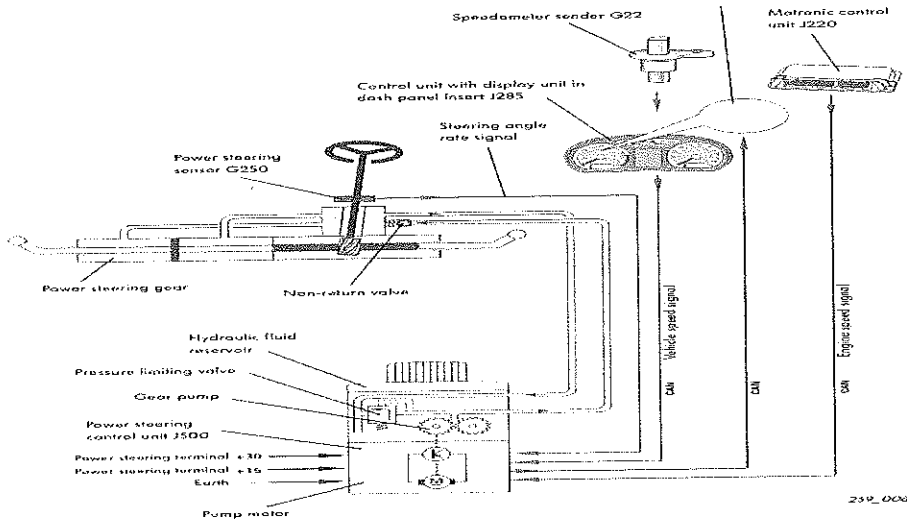

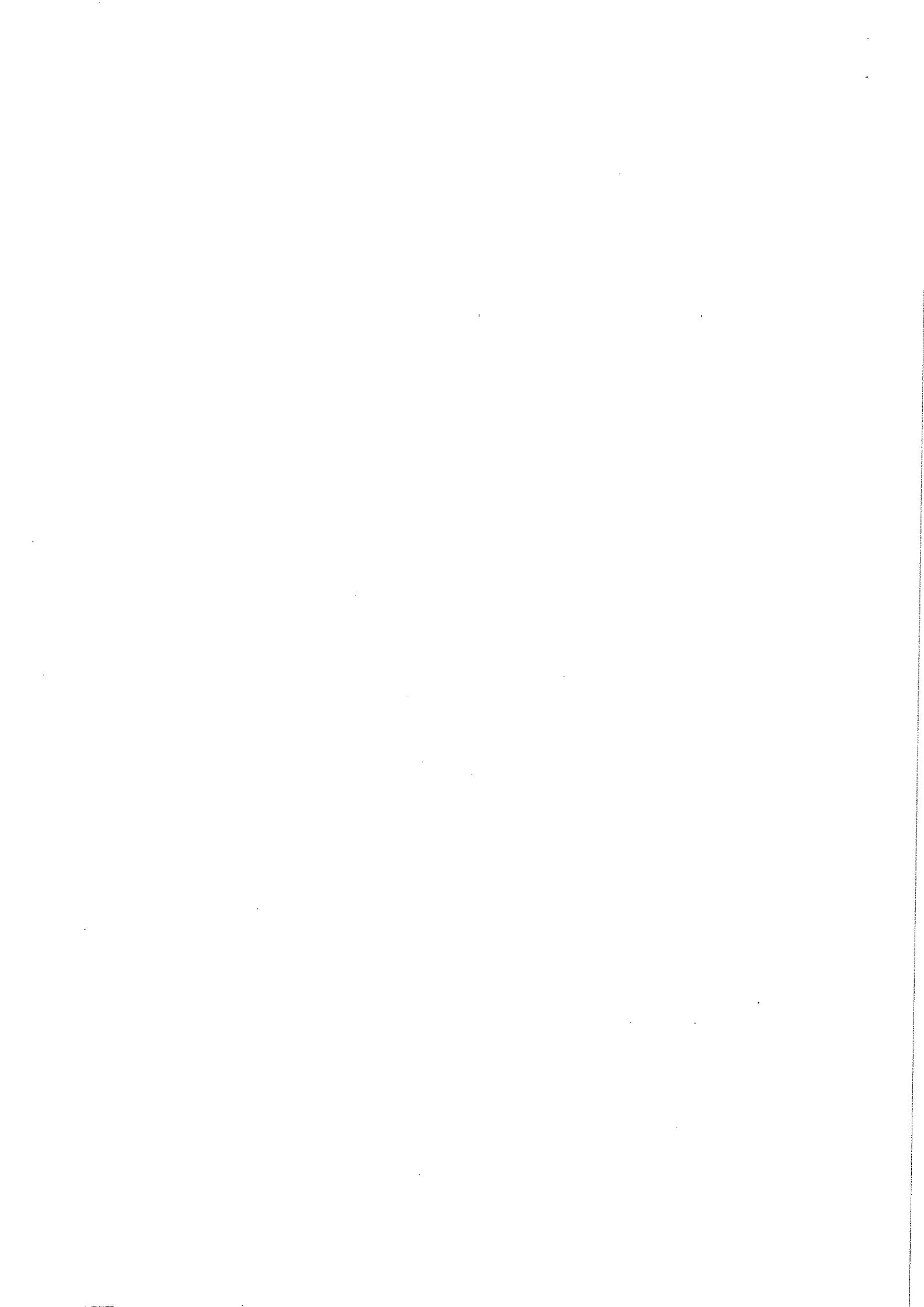



Registration No.:

School of Automotive Skills
Session: 2021-22 (Winter Semester)
B. Voc. Program, 3rd Semester
(Set A) End Sem. Examination

Course Code: AUT1303

Course Name: Automotive Body Works

Time: 2 Hour

Max. Marks: 50

Instruction:

1. Attempt all questions.
2. Use of Calculators is prohibited.
3. Section A contains 10 Questions. Each question carries 1 Marks.
4. Section B contains 4 Questions. Each question carries 4 Marks.
5. Section C contains 4 Questions. Each question carries 6 Marks.

Section – A

10X01 = 10 Marks

Q1. is the event in which two or more bodies exert forces on each other in about a relatively short time.

- a) Denting
- b) Bending
- c) Clamping
- d) Collision

Q2. Which of the following joint have high corrosion resistance?

- a) Welding joint
- b) Riveted joint
- c) Bolted joint
- d) None of the above

Q3. remover is essential for cleaning the surface prior to sanding or spraying undercoats or to coats.

- a) Wax and grease
- b) Putty
- c) Body filler
- d) Seam sealer

Q4. are typically used for hammer-forming flat sheet metal into custom shapes.



BHARTIYA SKILL DEVELOPMENT UNIVERSITY

- a) Sliding hammers
- b) Mallets
- c) Shears
- d) Nibblers

Q5. Which of the following types is not fillet weld?

- a) Butt joint
- b) T-joint
- c) lap joint
- d) Corner joint

Q6. is an essential tool for the quick removal of paint, primer and old body filler from an area being repaired?

- a) Sliding hammers
- b) Sander
- c) Shears
- d) Nibblers

Q7. is used to prevent moisture from getting into seams of a car.

- a) Degreaser
- b) Putty
- c) Body filler
- d) Seam sealer

Q8. is a lightweight, extremely strong, and robust material.

- a) Sheet metal
- b) Diamond
- c) Chassis
- d) Fiberglass

Q9. A slide hammer is used for in sheet metal.

- a) Restoring Bodyline
- b) Making Holes
- c) Pulling out dents
- d) None of these

Q10. Serrate head hammers are used for.....

- a) shrinking metal
- b) Panel flattening
- c) Restoring Bodylines
- d) All of the above



BHARTIYA SKILL DEVELOPMENT UNIVERSITY

Section – B

04X04 = 16 Marks

- Q11. Mention the differences between dolly-on and dolly-off hammering.
- Q12. What are the advantages of using sanding blocks during dry sanding?
- Q13. What is the use of spoons in an auto body repair?
- Q14. What are the advantages and disadvantages of chemical stripping?

Section – C

04X06 = 24 Marks

- Q15. Write short note on fiberglass and its applications
- Q16. Write steps to remove front bumper assembly.
- Q17. How to repair rusted Panels?
- Q18. Discuss the different categories of body filler.



School of Automotive Skills
Session: 2021-22 (Winter Semester)
B. Voc. Program, 3rd Semester
Answer sheet (Set A) End Sem. Examination

Course Code: AUT1303

Time: 2 Hour

Course Name: Automotive Body Works

Max. Marks: 50

Instruction:

1. Attempt all questions.
2. Use of Calculators is prohibited.
3. Section A contains 10 Questions. Each question carries 1 Marks.
4. Section B contains 4 Questions. Each question carries 4 Marks.
5. Section C contains 4 Questions. Each question carries 6 Marks.

Section – A

10X01 = 10 Marks

Q1. is the event in which two or more bodies exert forces on each other in about a relatively short time.

- a) Denting
- b) Bending
- c) Clamping
- d) **Collision**

Q2. Which of the following joint have high corrosion resistance?

- a) **Welding joint**
- b) Riveted joint
- c) Bolted joint
- d) None of the above

Q3. remover is essential for cleaning the surface prior to sanding or spraying undercoats or to coats.

- a) **Wax and grease**
- b) Putty
- c) Body filler
- d) Seam sealer

Q4.are typically used for hammer-forming flat sheet metal into custom shapes.

- a) Sliding hammers
- b) Mallets**
- c) Shears
- d) Nibblers

Q5. Which of the following types is not fillet weld?

- a) **Butt joint**
- b) T-joint
- c) lap joint
- d) Corner joint

Q6. is an essential tool for the quick removal of paint, primer and old body filler from an area being repaired?

- a) Sliding hammers
- b) Sander**
- c) Shears
- d) Nibblers

Q7. is used to prevent moisture from getting into seams of a car.

- a) Degreaser
- b) Putty
- c) Body filler
- d) Seam sealer**

Q8. is a lightweight, extremely strong, and robust material.

- a) Sheet metal
- b) Diamond
- c) Chassis
- d) Fiberglass**

Q9. A slide hammer is used for in sheet metal.

- a) Restoring Bodyline
- b) Making Holes
- c) Pulling out dents**
- d) None of these

Q10. Serrate head hammers are used for.....

- a) shrinking metal**
- b) Panel flattening
- c) Restoring Bodylines
- d) All of the above



Q11. Mention the differences between dolly-on and dolly-off hammering.

Ans. **Dolly- on hammering**

- Hold dolly against back of damage and hammer right over to of dolly.
- Repeatedly move point of hammer impact and dolly slightly, each blow overlapping.
- Start at outside and work towards center.
- Shapes of dolly and hammer must match desired shape of panel.
- Start with light hammer blows, and work up to stronger blows.

Dolly-off hammering

- It is used to raise low spots and lower high spot simultaneously.
- The hammer hits the panel slightly to one side of where the dolly is being held.
- It is often used to rough out or shape large areas of damage during initial straightening.

Q12. What are the advantages of using sanding blocks during dry sanding?

Ans: -

- Sanding blocks are commercially available in a wide variety of shapes, styles, size, and materials.
- Sanding can help you to get the best results, but without a sanding block you'll be wasting your time.
- Sanding blocks help you to exert even pressure on the sandpaper, while minimizing waves in the panel being sanded.

Q13

. What is the use of spoons in an auto body repair?

Ans: -

- Designed for used inside hard-to-reach areas.
- Spoons function like a body dolly with a handle.
- Often smaller and thinner than a dolly, they can be used inside of doors, fenders, hoods, or other double wall panels.
- They can also be used for prying panels outward from behind.

Q14. What are the advantages and disadvantages of chemical stripping?

Ans: -

Advantages

- It is used to remove all types of liquid as well as powder paints, lacquers, enamels & polyurethanes from the metal surface.
- It reduces the cleaning effort.
- It saves time.



BHARTIYA SKILL DEVELOPMENT UNIVERSITY

It strips large area like doors, panel, bonnet, etc.

- Capability to strip tough configurations.

Disadvantages

- It couldn't be applicable for plastic materials like front and rear bumper.
- Waste could be hazardous.
- It causes irritation while contact to our skins.
- Slow stripping rate.

Section – C

04X06 = 24 Marks

Q15. Write short note on fiberglass and its applications

Ans. **Fiberglass**

Fiberglass is a lightweight, extremely strong, and robust material. Fiberglass combines its light weight with an inherent strength to provide a weather resistant finish with a variety of surface textures.

Fiberglass really is made of glass, similar to windows or the drinking glasses in the kitchen. The glass is heated until it is molten, then it is forced through superfine holes, creating glass filaments that are very thin. fiberglass itself may be manufactured from recycled glass. Originally, fiberglass was a glass wool with fibers entrapping a great deal of gas, making it useful as an insulator, especially at high temperatures.

The basic raw materials for fiberglass products are a variety of natural minerals and manufactured chemicals. The major ingredients are silica sand, limestone, and soda ash. Silica sand is used as the glass former, and soda ash and limestone help primarily to lower the melting temperature. Waste glass, also called cullet, is also used as a raw material. The raw materials must be carefully weighed in exact quantities and thoroughly mixed together (called batching) before being melted into glass.

For custom work or bodywork repair, you can easily learn to work with fiberglass, a material doesn't require specialized equipment. Obviously, fiberglass can be used to repair components made of the same material, but it can also be used as an alternative to welding in sheet metal patch panels.

Fiberglass mat is commonly used when repairing holes or anywhere you need to build up bulk. Composed of short stands of glass fibers bound together, not woven, the mat is saturated with fiberglass resin, making it quite pliable and easy to form into complex shapes. As each layer of fiberglass mat is added, the laminate becomes thicker and stiffer.

Fiberglass cloth is more suitable to repairing cracks, breaks, or holes where there are few complex shapes. Since fiberglass cloth is made of woven glass thread, it is difficult to mold to curved shapes without wrinkling. To get the cloth to lie flat on a curved surface, several small cuts can be made in the cloth before the resin is applied. Fiberglass cloth is thinner than fiberglass mat, so avoid using cloth when your goal is to build up bulk in the repair area. However, a repair made with cloth will be stronger than a repaired area made with an equal thickness of mat, since the cloth contains a larger amount of glass.

Q16. Write steps to remove front bumper assembly.

Ans: - **Step 1-** Remove Front Beauty Cover

- Remove plastic push-pins holding the top plastic shroud that rests on top of the front clip and extends around the engine bay, including the weather-stripping used to seal out water.
- Once all pins are removed, peel back the weather stripping to loosen the cover.
- Pins locations shown with arrows in the photo below. Once free, set the cover aside.

Step 2- Remove Plastic fasteners

- Remove the plastic fasteners on the upper portion of the front bumper on each side.
- Use a flathead screw driver or the appropriate removal tool and pry upward.

Step 3 - Remove Upper portion bolts

- Remove the 10mm Bolts on the upper portion of the bumper as pictured.



BHARTIYA SKILL DEVELOPMENT UNIVERSITY

Step 4 - Remove Clips from Under Bumper

- Remove push pin clips from the bottom side of the bumper which hold the splash shield in place.
- Use a flathead screw driver or the appropriate removal tool and pry away.

Step 5 - Remove Clips from the fender areas

- Use a flathead screw driver or the appropriate removal tool and pry away.

Step 6 - Remove Front Clip

- Pull sides of front bumper outward until retention clips release on driver and passenger side.
- See photo below for arrows showing location of retention clips.
- After each side is successfully released, remove front bumper by pulling forward from the grill area. You will not be fully removing the bumper from the car at this moment.

Step 7 - Remove Fog Light Clips and Head Lamp Washer

Step 8 - Complete Removing the Front Bumper

- Fully remove the front bumper by continuing to pull forward in a slow motion.
- If removing the bumper yourself, its recommended to place a towel/blanket on the ground so that you do not scrape anything if dragged or dropped on the ground.

Q17. How to repair rusted Panels?

Ans: -

Although we usually envision collision repair whenever we think of automotive bodywork, rust repair is often just as common. Rust may be rare in some regions, but it is all too common in the rest of the world.

Anywhere that humidity meets unprotected sheet metal, rust is hard at work eating its way through your automobile's sheet metal. Sadly, you may not even know that the rust is present, as it tends to do its damage to area of your vehicle that you don't normally see during everyday operation. When you dealing with rust, you should determine whether it is just surface rust or a rust-through.

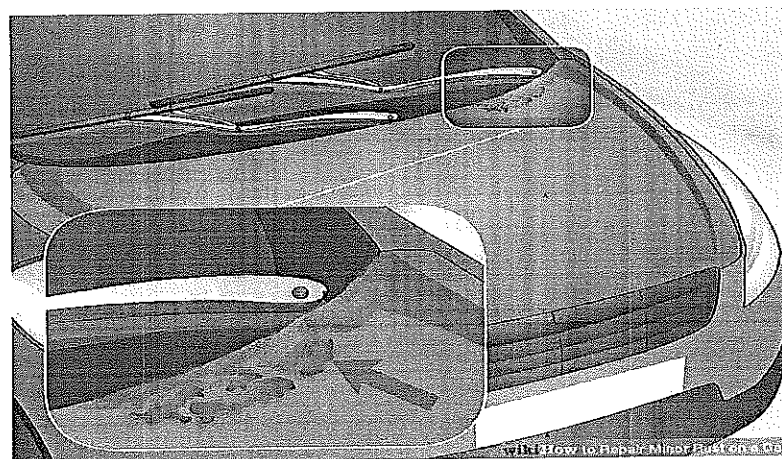

MINOR SURFACE RUST REMOVAL

- 1) Mask off the affected area with paint-appropriate tape. You want a few inches of protection surrounding the rust spot.



BHARTIYA SKILL DEVELOPMENT UNIVERSITY

- 2) Follow the directions on the rust remover, usually spraying or brushing it onto the rust and letting it sit for a few minutes. Then, wipe off any residue with a clean rag. Remember that rust remover is nasty stuff, so be sure to wear the appropriate protective gear when handling it.
- 3) The rust should be gone, but remove any leftover rust with sandpaper.
- 4) Clean with a grease and wax remover soap, then air dry.
- 5) Spray primer in a light-to-medium coat, and allow an hour to dry. Spray three coats.
- 6) Spray the color base coat, going thinner than the primer. You may have to do five or six coats for complete coverage. Give it plenty of time between coats to prevent drips.
- 7) Spray the clear coat. Wait two or 3 days before washing, and wait a minimum of two months (some body shops suggest waiting for six) before waxing.

MAJOR RUST REMOVAL

- 1) Mask off the affected area. If sanding through paint and primer, cover the rest of the vehicle to protect it from the super-fine dust.
- 2) Use a grinder with a sanding wheel to remove as much surface rust as you can. When removing the rust, remember not to bear down any heavier than you absolutely need to.
- 3) Clean the work area with grease remover.
- 4) Use a fiberglass-reinforced body filler for holes and depressions left over after digging out the rust. Allow it to cure completely. This could take quite some time, and shouldn't be done at all if it's any cooler than about 65 degrees outside.
- 5) Sand the filler with progressively finer grit sandpaper, and then clean with wax and grease remover.
- 6) Tape off the area to be painted.
- 7) Use the self-etching primer and wait the required drying time.
- 8) Spray several light coats of paint.
- 9) Finish with a coat or two of clear. Like above, hold off on washing and waxing.

Q18. Discuss the different categories of body filler.

Ans: - Body fillers are generally polyester resin based filler with a creme hardener that can be used to even out dents and cover blemishes on vehicles.

- Body fillers all fall into three general categories: standard, mid-range, and premium, and are generally available in a two-part material consisting of a polyester resin and a creme hardener.
- The filler grade you select will depend on the scope of the project and the size of the damaged spots needing to be repaired.
- Standard grade is a great option for minimal hail damage and small rust spots, while premium grade should be used for actual tears or a large surface area.



U.P. got B

School of Automotive Skills
Session: 2021-22 (Winter Semester)
B. Voc. Program, 3rd Semester
(Set B) End Sem. Examination

Course Code: AUT1303

Time: 2 Hour

Course Name: Automotive Body Works

Max. Marks: 50

Instruction:

1. Attempt all questions.
2. Use of Calculators is prohibited.
3. Section A contains 10 Questions. Each question carries 1 Marks.
4. Section B contains 4 Questions. Each question carries 4 Marks.
5. Section C contains 4 Questions. Each question carries 6 Marks.

Section – A

10X01 = 10 Marks

Q1. Write the name of the joint type:

- a) Butt Joint
- b) I-Joint
- c) Corner Joint
- d) T-Joint

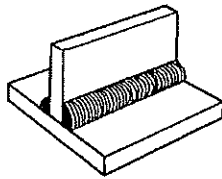

Q2. Tungsten has high melting point ...

- a) 4322°C
- b) 43222°C
- c) 43322°C
- d) 3322°C

Q3. How many panels are there in a car body?

- a) 13
- b) 15
- c) 06
- d) 12

Q4. is the event in which two or more bodies exert forces on each other in about a relatively short time.





BHARTIYA SKILL DEVELOPMENT UNIVERSITY

- a) Denting
- b) Bending
- c) Clamping
- d) Collision

Q5.are typically used for hammer-forming flat sheet metal into custom shapes.

- a) Sliding hammers
- b) Mallets
- c) Shears
- d) Nibblers

Q6. Which of the following types is not fillet weld?

- a) Butt joint
- b) T-joint
- c) lap joint
- d) Corner joint

Q7. Which of the following joint have high corrosion resistance?

- a) Welding joint
- b) Riveted joint
- c) Bolted joint
- d) None of the above

Q8.is used to prevent moisture from getting into seams of a car.

- a) Degreaser
- b) Putty
- c) Body filler
- d) Seam seal

Q9. is a lightweight, extremely strong, and robust material.

- a) Sheet metal
- b) Diamond
- c) Chassis
- d) Fiberglass

Q10. is an essential tool for the quick removal of paint, primer and old body filler from an area being repaired?

- a) Sliding hammers
- b) Sander
- c) Shears
- d) Nibblers

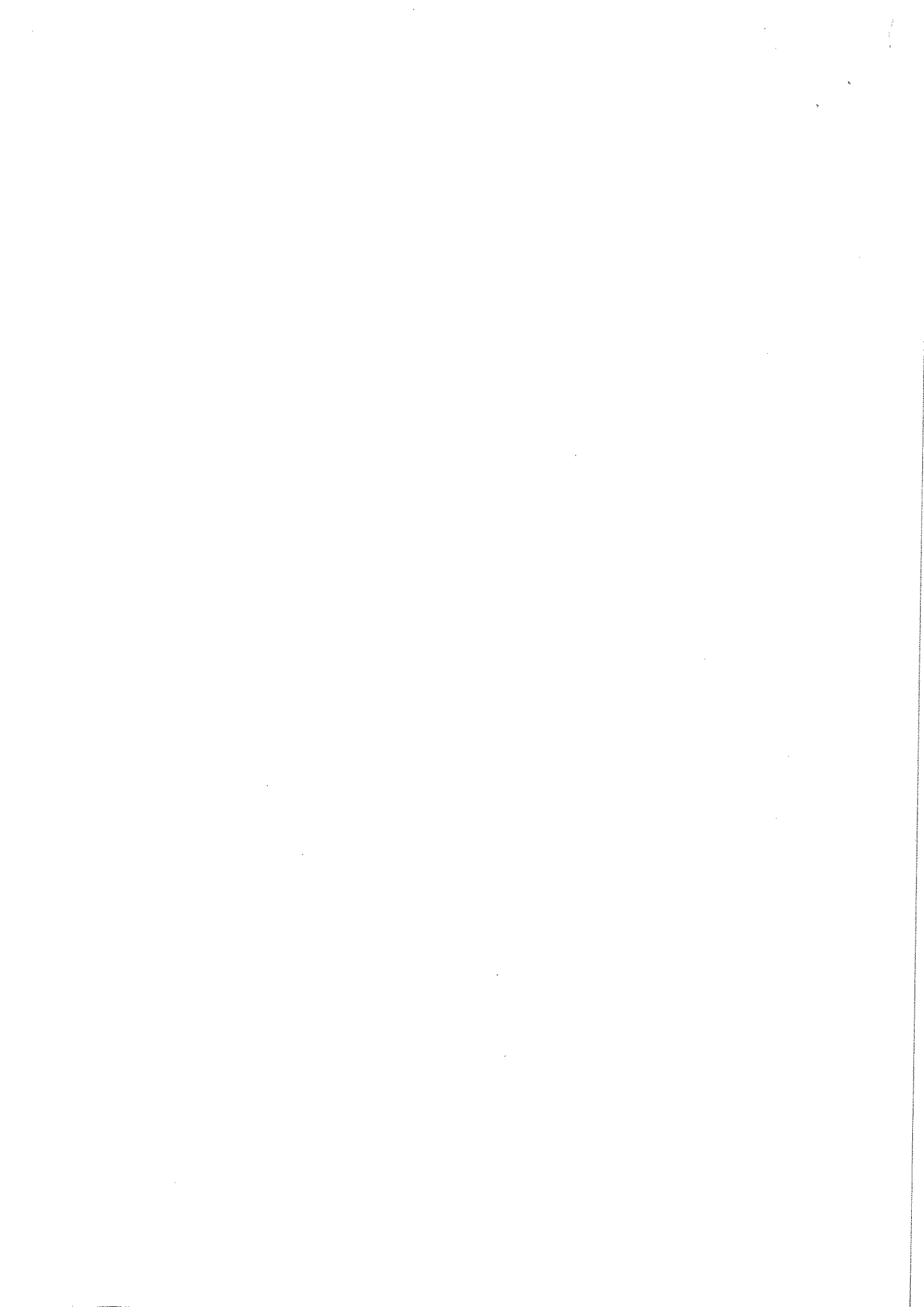



Section – B

04X04 = 16 Marks

- Q11. Write short note on sanding and grinding.
- Q12. Mention the differences between dolly-on and dolly-off hammering.
- Q13. What are the advantages and disadvantages of chemical stripping?
- Q14. Write the names of different tools used in auto bodywork.

Section – C

04X06 = 24 Marks

- Q15. Explain window mechanism with diagram
- Q16. Write short note on fiberglass and its applications
- Q17. Write steps to remove front bumper assembly.
- Q18. How to Replace a Windshield?

[Handwritten signature]



School of Automotive Skills
Session: 2021-22 (Winter Semester)
B. Voc. Program, 3rd Semester
Answer sheet (Set B) End Sem. Examination

Course Code: AUT1303

Course Name: Automotive Body Works

Time: 2 Hour

Max. Marks: 50

Instruction:

1. Attempt all questions.
2. Use of Calculators is prohibited.
3. Section A contains 10 Questions. Each question carries 1 Marks.
4. Section B contains 4 Questions. Each question carries 4 Marks.
5. Section C contains 4 Questions. Each question carries 6 Marks.

Section – A

10X01 = 10 Marks

Q1. Write the name of the joint type:

- a) Butt Joint
- b) I-Joint
- c) Corner Joint
- d) T-Joint

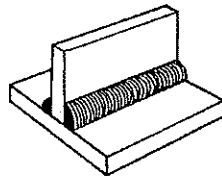

Q2. Tungsten has high melting point ...

- a) 4322°C
- b) 43222°C
- c) 43322°C
- d) 3322°C

Q3. How many panels are there in a car body?

- a) 13
- b) 15
- c) 06
- d) 12

Q4. is the event in which two or more bodies exert forces on each other in about a relatively short time.

- a) Denting
- b) Bending
- c) Clamping
- d) **Collision**

Q5.are typically used for hammer-forming flat sheet metal into custom shapes.

- a) Sliding hammers
- b) **Mallets**
- c) Shears
- d) Nibblers

Q6. Which of the following types is not fillet weld?

- a) **Butt joint**
- b) T-joint
- c) lap joint
- d) Corner joint

Q7. Which of the following joint have high corrosion resistance?

- a) **Welding joint**
- b) Riveted joint
- c) Bolted joint
- d) None of the above

Q8.is used to prevent moisture from getting into seams of a car.

- a) Degreaser
- b) Putty
- c) Body filler
- d) **Seam sealer**

Q9. is a lightweight, extremely strong, and robust material.

- a) Sheet metal
- b) Diamond
- c) Chassis
- d) **Fiberglass**



Q10. is an essential tool for the quick removal of paint, primer and old body filler from an area being repaired?

- a) Sliding hammers
- b) **Sander**
- c) Shears
- d) Nibblers

Section – B

04X04 = 16 Marks

Q11. Write short note on sanding and grinding.

Ans. Grinding

A grinder is a power tool with a spinning abrasive disc, used for grinding, smoothing, and shaping materials, usually metal.

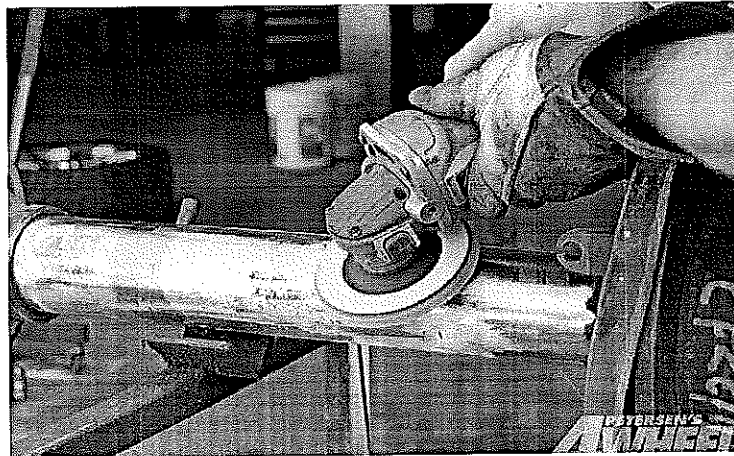

Sanding

Sanding is the process of smoothing or polishing a surface with sandpaper.



Q12. Mention the differences between dolly-on and dolly-off hammering.

Ans. Dolly- on hammering

- Hold dolly against back of damage and hammer right over to of dolly.
- Repeatedly move point of hammer impact and dolly slightly, each blow overlapping.



BHARTIYA SKILL DEVELOPMENT UNIVERSITY

- Start at outside and work towards center.
- Shapes of dolly and hammer must match desired shape of panel.
- Start with light hammer blows, and work up to stronger blows.

Dolly-off hammering

- It is used to raise low spots and lower high spot simultaneously.
- The hammer hits the panel slightly to one side of where the dolly is being held.
- It is often used to rough out or shape large areas of damage during initial straightening.

Q13. What are the advantages and disadvantages of chemical stripping?

Ans: -

Advantages

- It is used to remove all types of liquid as well as powder paints, lacquers, enamels & polyurethanes from the metal surface.
- It reduces the cleaning effort.
- It saves time.
- It strips large area like doors, panel, bonnet, etc.
- Capability to strip tough configurations.

Disadvantages

- It couldn't be applicable for plastic materials like front and rear bumper.
- Waste could be hazardous.
- It causes irritation while contact to our skins.
- Slow stripping rate.

Q14. Write the names of different tools used in auto bodywork.

Ans: - Basic tools like hammers, mallets, dollies, sanding blocks, spoons, portable grinders and sanders, stud welders and slide hammers, panel flangers, pneumatic tools, chisel, nibblers, clamps, etc.

Section – C

04X06 = 24 Marks

Q15. Explain window mechanism with diagram

Windows Mechanisms

Among the items in the door that that can be damaged, other key areas include the window glass, the window riser mechanism (manual or electric), and the window channel in which the glass slides. If they are damaged, these items are most likely to require replacement, rather than repair. Anything that cause glass to be misaligned or in a bind will eventually lead it to break, so it is better to replace the necessary parts now while the vehicle is disassembled, instead of waiting until later, when you will have to disassemble and reassemble the door again.

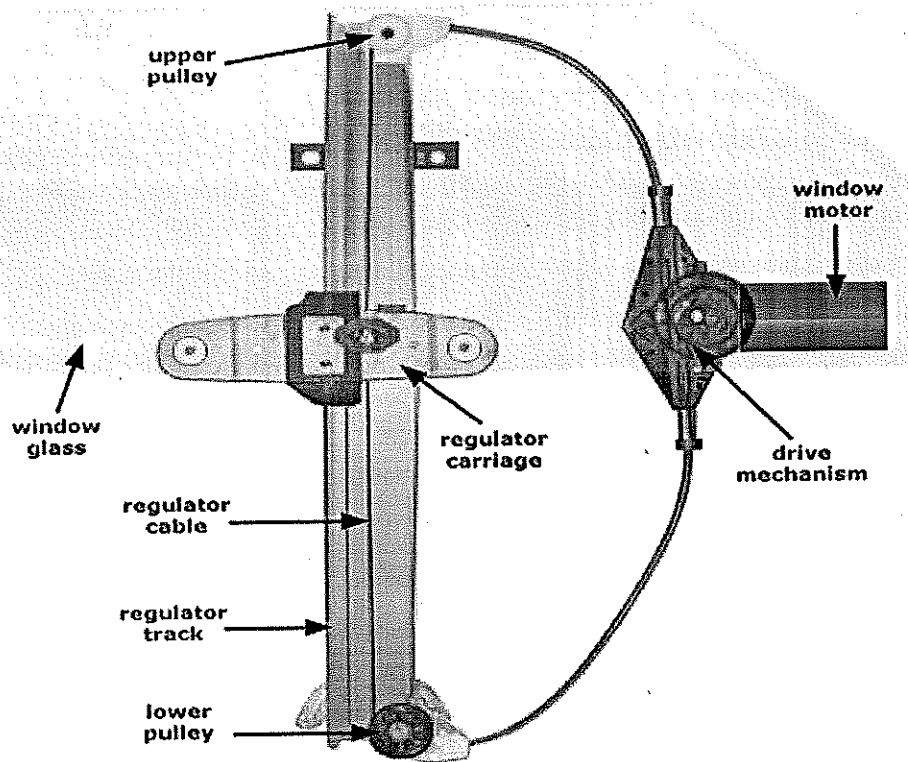
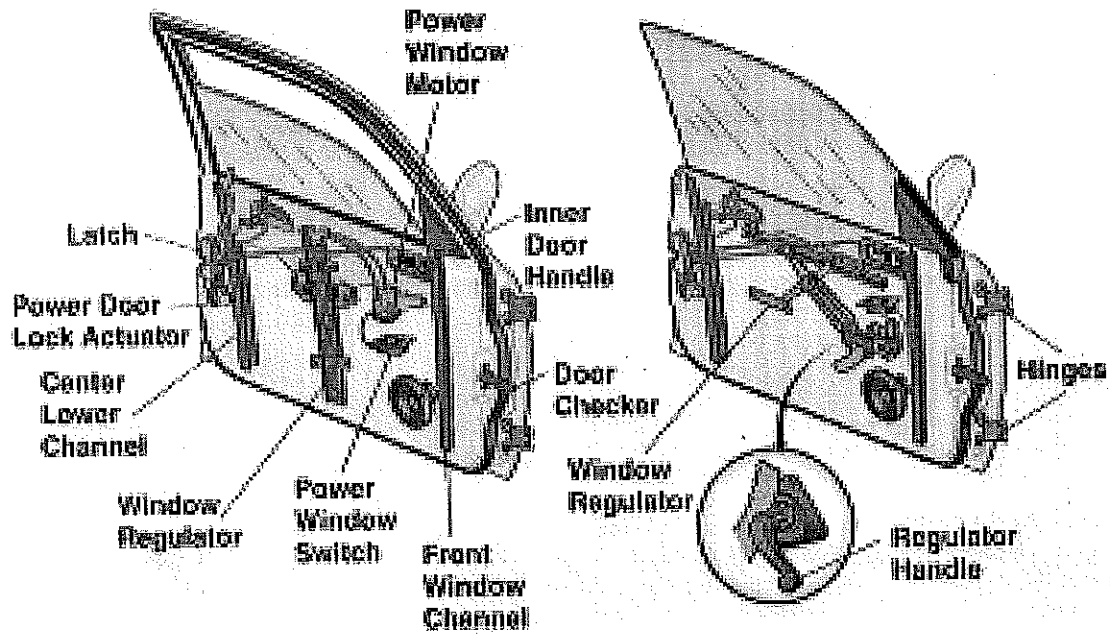

Q16. Write short note on fiberglass and its applications

Ans. Fiberglass

Fiberglass is a lightweight, extremely strong, and robust material. Fiberglass combines its light weight with an inherent strength to provide a weather resistant finish with a variety of surface textures.

Fiberglass really is made of glass, similar to windows or the drinking glasses in the kitchen. The glass is heated until it is molten, then it is forced through superfine holes, creating glass filaments that are very thin. fiberglass itself may be manufactured from recycled glass. Originally, fiberglass was a glass wool with fibers entrapping a great deal of gas, making it useful as an insulator, especially at high temperatures.



BHARTIYA SKILL DEVELOPMENT UNIVERSITY

The basic raw materials for fiberglass products are a variety of natural minerals and manufactured chemicals. The major ingredients are silica sand, limestone, and soda ash. Silica sand is used as the glass former, and soda ash and limestone help primarily to lower the melting temperature. Waste glass, also called cullet, is also used as a raw material. The raw materials must be carefully weighed in exact quantities and thoroughly mixed together (called batching) before being melted into glass.

For custom work or bodywork repair, you can easily learn to work with fiberglass, a material doesn't require specialized equipment. Obviously, fiberglass can be used to repair components made of the same material, but it can also be used as an alternative to welding in sheet metal patch panels.

Fiberglass mat is commonly used when repairing holes or anywhere you need to build up bulk. Composed of short stands of glass fibers bound together, not woven, the mat is saturated with fiberglass resin, making it quite pliable and easy to form into complex shapes. As each layer of fiberglass mat is added, the laminate becomes thicker and stiffer.

Fiberglass cloth is more suitable to repairing cracks, breaks, or holes where there are few complex shapes. Since fiberglass cloth is made of woven glass thread, it is difficult to mold to curved shapes without wrinkling. To get the cloth to lie flat on a curved surface, several small cuts can be made in the cloth before the resin is applied. Fiberglass cloth is thinner than fiberglass mat, so avoid using cloth when your goal is to build up bulk in the repair area. However, a repair made with cloth will be stronger than a repaired area made with an equal thickness of mat, since the cloth contains a larger amount of glass.

Q17. Write steps to remove front bumper assembly.

Ans: - Step 1- Remove Front Beauty Cover

- Remove plastic push-pins holding the top plastic shroud that rests on top of the front clip and extends around the engine bay, including the weather-stripping used to seal out water.
- Once all pins are removed, peel back the weather stripping to loosen the cover.
- Pins locations shown with arrows in the photo below. Once free, set the cover aside.

Step 2- Remove Plastic fasteners

- Remove the plastic fasteners on the upper portion of the front bumper on each side.
- Use a flathead screw driver or the appropriate removal tool and pry upward.

Step 3 - Remove Upper portion bolts

- Remove the 10mm Bolts on the upper portion of the bumper as pictured.

Step 4 - Remove Clips from Under Bumper

- Remove push pin clips from the bottom side of the bumper which hold the splash shield in place.
- Use a flathead screw driver or the appropriate removal tool and pry away.

Step 5 - Remove Clips from the fender areas

- Use a flathead screw driver or the appropriate removal tool and pry away.

Step 6 - Remove Front Clip

- Pull sides of front bumper outward until retention clips release on driver and passenger side.
- See photo below for arrows showing location of retention clips.
- After each side is successfully released, remove front bumper by pulling forward from the grill area. You will not be fully removing the bumper from the car at this moment.

Step 7 - Remove Fog Light Clips and Head Lamp Washer

Step 8 - Complete Removing the Front Bumper

- Fully remove the front bumper by continuing to pull forward in a slow motion.



- If removing the bumper yourself, its recommended to place a towel/blanket on the ground so that you do not scrape anything if dragged or dropped on the ground.

Q18. How to Replace a Windshield?

Ans: -

- There are basically two types of windows in an automobile: fixed glass and opening glass. Fixed glass is used in windows that do not open, such as the windshield, back window, and rear quarter windows.
- Glass from fixed windows is taken out by first removing any trim around the window seal, removing the rubber by using a special tool designed for the task, then pushing the window glass outward. Any residual window caulk or sealant must be removed from the sheet metal around the window opening. Some of these windows are glued in place, while others are held in place by rubber weather strip. For the type that is glued in place, the sheet metal window opening must be free of debris or broken glass and clean and free of contaminants; this can be ensure by cleaning with wax and grease remover, then applying the glue to the flange in the windows opening. The glass is then set into position and pressed into place to ensure full contact with the glue. Leave the vehicle for the proper amount of time for the glue to set.
- For the glass that is secured by weather strip, as with the glued-in type, the sheet metal window opening must be clean. The rubber weather strip is stretched around the window glass, making sure that the weather strip is properly oriented around the glass. Spray silicone is then applied to the inside lip of the weather strip and a thin cord or rope (about 1/8 inch in diameter) is slid into the lip that fits around the flange in the window opening. The cord or rope should overlap at the top or bottom of the glass so that it protrudes toward the inside of the vehicle long enough that you can hold opposite ends of the rope in each hand.
- With the help of an assistant, the glass and weather strip is set in place outside the vehicle. By pulling the rope inward (out of the weather strip), the weather strip can pass over the window opening flange. The cord or rope is pulled in slowly while the assistant outside of the vehicle pushes the glass in place.





BHARTIYA SKILL DEVELOPMENT UNIVERSITY

School of Automotive Skills
Session: 2021-22 (Winter Semester)
B. Voc. Program, 3rd Semester,
End-Sem. Examination

Course Code: AUT1304

Time: 2 Hour

Course Name: Automotive Refinish Painting

Max. Marks: 50 marks

Instruction:

1. Answer all questions from section A, each question carries one mark
2. Answer all question from section B, each question carries two mark.
3. Answer all question from section C, each question carries three mark.

Section – A

10X01 = 10 Marks

Q-1. What does 2-k represent?

- | | |
|--------------------------|-----------------------------|
| a. 1000 | c. Product without hardener |
| b. Product with hardener | d. None of these |

Q-2. Wash primer is a.....primer?

- | | |
|--------|----------------------|
| a. 1 K | c. Both A & B |
| b. 2 K | d. None of the above |

Q-3. The Minimum lux required for light in paint booth color inspection is...

- | | |
|-------------|---------------------|
| a. 1200 lux | c. 2000 lux |
| b. 500 lux | d. All of the above |

Q-4. What is the best way of sanding Putty and Body filler?

- | | |
|---------------------|----------------------------|
| a. Dry guide coat | c. Cleaning with degreaser |
| b. Air less sanding | d. Both (a) and (c) |

Q-5. Which of the following are Primary colors?

- | | |
|--------------------------|-------------------------|
| a. Red, blue & yellow | c. Violet, green & blue |
| b. lime, orange & violet | d. Red, orange & blue |

Q-6. What is the mixing ratio (in gram) of Body filler available in workshop?

- | | |
|-----------|------------------------|
| a. 100: 2 | c. 100:12 |
| b. 100:10 | d. As per manufacturer |

Q-7. Which of the following paint layer is not a part of refinish painting?

- a. Electro Phosphating
- b. Epoxy primer
- c. Polyester putty
- d. Body filler

Q-8. What is the purpose of dry coat?

- a. To facilitate sanding
- b. To remove dust
- c. a & b
- d. None of the above

Q-9. Which paint is not more environment friendly?

- a. NC Paints
- b. Synthetic paints
- c. PU Paint
- d. All of the above

Q-10. What is the baking temperature for 2k refinish paint?

- a. 45 degree Celsius
- b. 60 degree Celsius
- c. 90 degree Celsius
- d. 120 degree Celsius

Section – B

04X04 = 16 Marks

Q11. What is color, explain Oswald munsell theory.

Q12. What is chroma, write chroma property on hue circle.

Q13. What are the Materials used for masking? What are their uses.

Q-14. Write down the SOP of Spot Repair?

Section – C

06X04 = 24 Marks

Q15. Explain paint quality inspection and usage of tools in inspection.

Q16. What are the causes, prevention and remedies for water spotting and color fade?

Q17. Write note on pearlescent color.

Q-18. What is the difference between wash Primer and Surfacer?

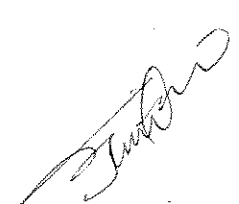



BHARTIYA SKILL DEVELOPMENT UNIVERSITY

School of Automotive Skills

Session: 2021-22 (Winter Semester)

B. Voc. Program, 3rd Semester,

End-Sem. Examination

Course Code: AUT1304

Time: 2 Hour

Course Name: Automotive Refinish Painting

Max. Marks: 50 marks

Instruction:

1. Answer all questions from section A, each question carries one mark
2. Answer all question from section B, each question carries two mark.
3. Answer all question from section C, each question carries three mark.

Section – A

10X01 = 10 Marks

Q-1. What does 2-k represent?

- | | |
|--------------------------|-----------------------------|
| a. 1000 | c. Product without hardener |
| b. Product with hardener | d. None of these |

Q-2. Wash primer is a.....primer?

- | | |
|--------|----------------------|
| a. 1 K | c. Both A & B |
| b. 2 K | d. None of the above |

Q-3. The Minimum lux required for light in paint booth color inspection is...

- | | |
|-------------|---------------------|
| a. 1200 lux | c. 2000 lux |
| b. 500 lux | d. All of the above |

Q-4. What is the best way of sanding Putty and Body filler?

- | | |
|---------------------|----------------------------|
| a. Dry guide coat | c. Cleaning with degreaser |
| b. Air less sanding | d. Both (a) and (c) |

Q-5. Which of the following are Primary colors?

- | | |
|--------------------------|-------------------------|
| a. Red, blue & yellow | c. Violet, green & blue |
| b. lime, orange & violet | d. Red, orange & blue |

Q-6. What is the mixing ratio (in gram) of Body filler available in workshop?

- | | |
|-----------|------------------------|
| a. 100: 2 | c. 100:12 |
| b. 100:10 | d. As per manufacturer |

Q-7. Which of the following paint layer is not a part of refinish painting?

- a. **Electro Phosphating**
- b. Epoxy primer
- c. Polyester putty
- d. Body filler

Q-8. What is the purpose of dry coat?

- a. **To facilitate sanding**
- b. To remove dust
- c. a & b
- d. None of the above

Q-9. Which paint is not more environment friendly?

- a. NC Paints
- b. Synthetic paints
- c. PU Paint
- d. All of the above

Q-10. What is the baking temperature for 2k refinish paint?

- a. 45 degree Celsius
- b. **60 degree Celsius**
- c. 90 degree Celsius
- d. 120 degree Celsius

Section – B

04X04 = 16 Marks

Q11. What is color, explain Oswald munsell theory.

Ans. Definition of color?

- It is an individual and subjective observation.
- The reflected part of the light spectrum on a certain material, observed by the human eye

Oswald Munsell Theory:

Oswald Theory: -

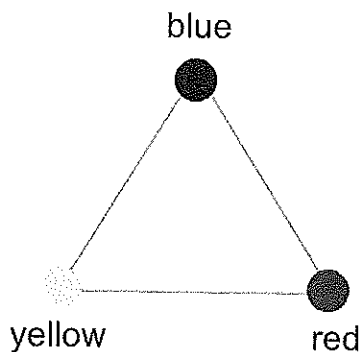

PRIMARY COLOURS

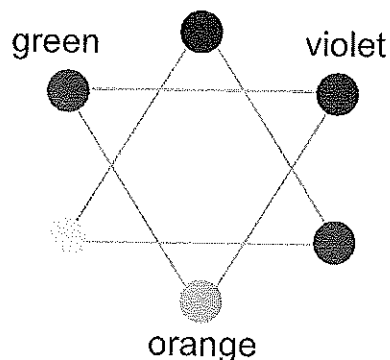

SECONDARY COLOURS

Munsell Theory:-

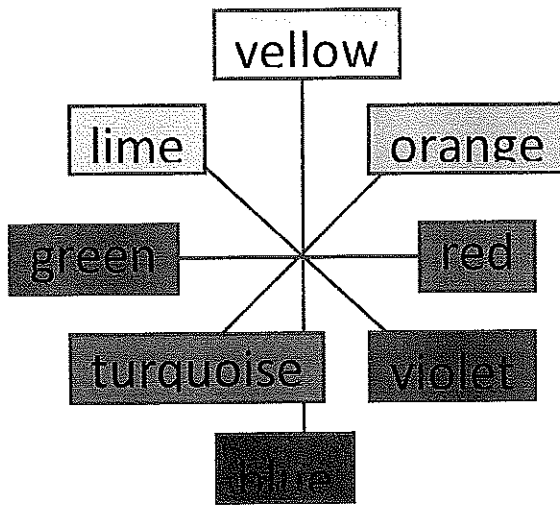

Q12. What is chroma, write chroma property on hue circle.

Ans. Chroma: -

1. The attribute with which we can classify colour on the basis of their Brightness and dullness is called Chroma.

Chroma property on hue circle: -

1. Recall that neutral colours have no hue and no Chroma.
2. A Chroma sequence varying from low to high Chroma is placed on a radius of the hue circle
3. A maximum Chroma colour of a particular hue is placed at the outer edge of the hue circle
4. The neutral colour is placed at the centre of the hue circle.

Q13. What are the Materials used for masking? What are their uses.

Ans. In order to carry out this process of masking we have range of materials such as: -

- Masking Paper
- Plastic sheet masking
- Masking tapes
- Caps and plugs
- Masking rope

Masking Paper

1. Paper has been and is the material most used to mask or protect areas not to paint.
2. It is used to resist the solvents and diluents containing in the paint.

3. It has low acquisition cost and easy of placement on flat surfaces.

Plastic sheet masking

4. The plastic sheet masking has been the technological evolution of the paper in masking
5. It has characteristics of resistance to solvents, temperature and handling.
6. The main advantage of using these films is the easy adaptation to the contours.

Masking tapes

Among the wide range of masking tapes on the market, we can classify them into three groups:

- General masking tapes
- Fine masking tapes
- Trim masking tapes

Plugs and caps

1. The use of plugs for masking or covering of nuts and both plain and threaded holes.
2. Generally, are made of silicone because of its high resistance to solvents, temperature and handling.

Masking rope

1. Masking rope are self-adhesive foam strips used in holes and openings.
2. This type of masking material is used on the edges of the doors, hinged covers
3. The purpose of masking rope is to prevent the penetration of the spray paint into the hole

Q-14. Write down the SOP of Spot Repair?

Ans.

Step 1: Pre-Cleaning

Step 2: Initial Prep Sand the spotted area with P320 and interface pad

Step 3: Mix and Apply Filler

Step 4: Sand Filler

Step 5: Mix and Apply PU Primer Surfacer

Step 6: Sand the Surfacer with Soft disc

Step 7: Mix the paint according to the required shade and apply on spot in one and half coat.

Step 8: Apply clear coat if Required

Section – C

06X04 = 24 Marks

Q15. Explain paint quality inspection and usage of tools in inspection.

Ans. Paint Quality inspection.

There are several different tests to measure the resistance of paints and coatings from substrates:

- cross-cut test
- scrape adhesion
- pull-off test
- Impact test
- Salt test
- Bending test.

Usage of Tools in Inspection – DFT meter

Gloss meter

A gloss meter (also gloss meter) is an instrument which is used to measure specular reflection gloss of a surface. Gloss is determined by projecting a beam ...

Gloss Range: 60° Value

Medium Gloss: 10 - 70 GU

High Gloss: >70 GU

Low Gloss: <10 GU

Gloss is determined by projecting a beam of light at a fixed intensity and angle onto a surface and measuring the amount of reflected light at an equal but opposite angle. 0° is referred to as the universal measurement angle and is the most commonly specified geometry in applications such as paints, coatings, plastics, automotive interiors and general manufacturing. It can be used as a basic gloss assessment for any surface from matt surfaces to mirror finish polished metals.

Viscometer- Ford Cup-4.

Ford flow cup viscometers are used to measure liquids quickly and easily in order to determine their viscosity. However, it must be taken into account that this is only possible with less viscous liquids. Viscous pastes and other substances with a high viscosity are not suitable for measurement with a flow cup.



The unit of viscosity is newton-second per square metre, which is usually expressed as Pascal-second in SI units.

Q16. What are the causes, prevention and remedies for water spotting and color fade?

Ans. 1. Water spotting

Causes: -

- Vehicles washed with water from "hard" water supply.
- Visible on dark colours, particularly on vehicles washed in direct sunlight.

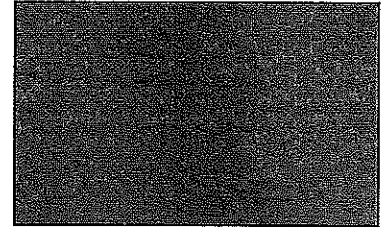

Prevention: -

- Never wash vehicles with household detergent.
- Rinse vehicle with chemically softened water.
- Dry vehicle directly after washing.

Remedies: -

- Wash vehicle with wax containing shampoo.
- Dry with damp leather cloth.
- Severe stains may need polishing to remove.

2. Color fade

Causes: -

- Sunlight UV light effect on certain paint pigments in surface.
- Refinish paints of low quality with little or no UV blocker.

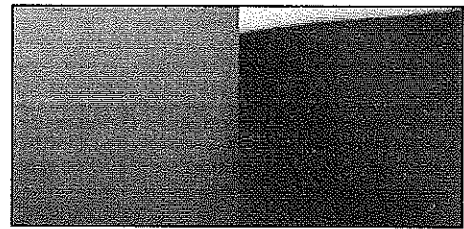

Prevention: -

- Frequent wax polishing to provide protection.

Remedies: -

- Can be removed in part by machine polishing with fine abrasive paste.
- Avoid over polishing, can be checked with film thickness gauge.
- Refinish if necessary

Q17. Write note on pearlescent color.

Ans. Pearlescent Color/ 3satge Color.

The pearlescent lustre is created by ceramic crystals in the paint that both reflect and refract light. That gives the colour a depth that even metallic simply can't match. These Pearlescent Paints Diamond offer a choice of 38 bright and vivid colours, where each user will be able to find a shade to his or her taste. Diamond is a new type of paint based on mother-of-pearl silicon glass, ultra-reflective and a mixture of Candy inks.

Whereas a metallic paint job adds powdered metal to its mixture, a pearlescent paint job swaps this for ceramic crystals (also known as mica). What's appealing about pearlescent finishes is that the crystal details in the paint not only reflect light more than solid paint, but it also refracts the light too.

Clear Coat Layer

Pearl/Smoke/Candy Layer (always translucent)

Base Color Layer (first visible layer)

Primer/Sealer Layer

Car Body (Metal/Polyurethane/Plastic)

Pearlescent paints incorporate shiny ceramic crystals (known as mica crystals) into the paint mixture. These crystals give the paint its namesake pearl-like effect. Like pearls, vehicles with pearlescent paint tend to 'glow' and shift colours under different types of light and the angle at which the car is viewed.

The difference between pearlescent and iridescent: pearlescent is pearl-like in either colour or lustre, while iridescence produces a display of lustrous, prismatic and rainbow-like colours.

As adjectives the difference between pearlescent and opalescent. is that pearlescent is pearl-like, either in colour or lustre while opalescent is exhibiting a milky iridescence like that of an opal.

Q-18. What is the difference between wash Primer and Surfacer?

Ans. The wash primer is a specific type of primer designed to protect metal and allow good adhesion of paint. So when you are painting metal, it's essential to use this product to prevent the material itself from causing the paint to deteriorate and peel off. The wash primer is applied using a paint spray gun and the film thickness is usually 0.3-0.5 mils. The acid etches the metal surface and provides for good adhesion. A conversion coating is a slightly acidic aqueous solution (water-based) of chemicals.

Objects such as stainless steel and anodized parts should be sanded to loosen the anodized portion and promote adhesion of the wash primer. For anodized aluminum of architectural grade, the surface should be sanded using 40-80 grit sandpaper until the profile of the surface can be seen.





BHARTIYA SKILL DEVELOPMENT UNIVERSITY

School of Automotive Skills

Session: 2021-22 (Winter Semester)

B. Voc. Program, 3rd Semester,

End-Sem. Examination

Registration No.:

O.P. S. R.

Course Code: AUT1304

Time: 2 Hour

Course Name: Automotive Refinish Painting

Max. Marks: 50 marks

Instruction:

1. Answer all questions from section A, each question carries one mark
2. Answer all question from section B, each question carries two mark.
3. Answer all question from section C, each question carries three mark.

Section – A

10X01 = 10 Marks

Q-1. What does 1-k represent?

- a. 1000
- b. Product with hardener
- c. Product without hardener
- d. None of these

Q-2. Surfacer primer is a.....primer?

- a. 1 K
- b. 2 K
- c. Both A & B
- d. None of the above

Q-3. The appropriate light for color inspection is...

- a. Sun light
- b. Sodium light
- c. LED light
- d. All of the above

Q-4. What is the best way of removing the dust particles after putty dry sanding?

- a. Air blowing
- b. Cleaning with thinner
- c. Cleaning with degreaser
- d. Both (a) and (c)

Q-5. Which of the following are secondary colors?

- a. Red, blue & yellow
- b. lime, orange & violet
- c. Violet, green & blue
- d. Red, orange & blue

Q-6. What is the mixing ratio (in gram) of polyester putty & hardener available in workshop?

- a. 100: 2
- b. 100:10
- c. 100:12
- d. As per manufacturer

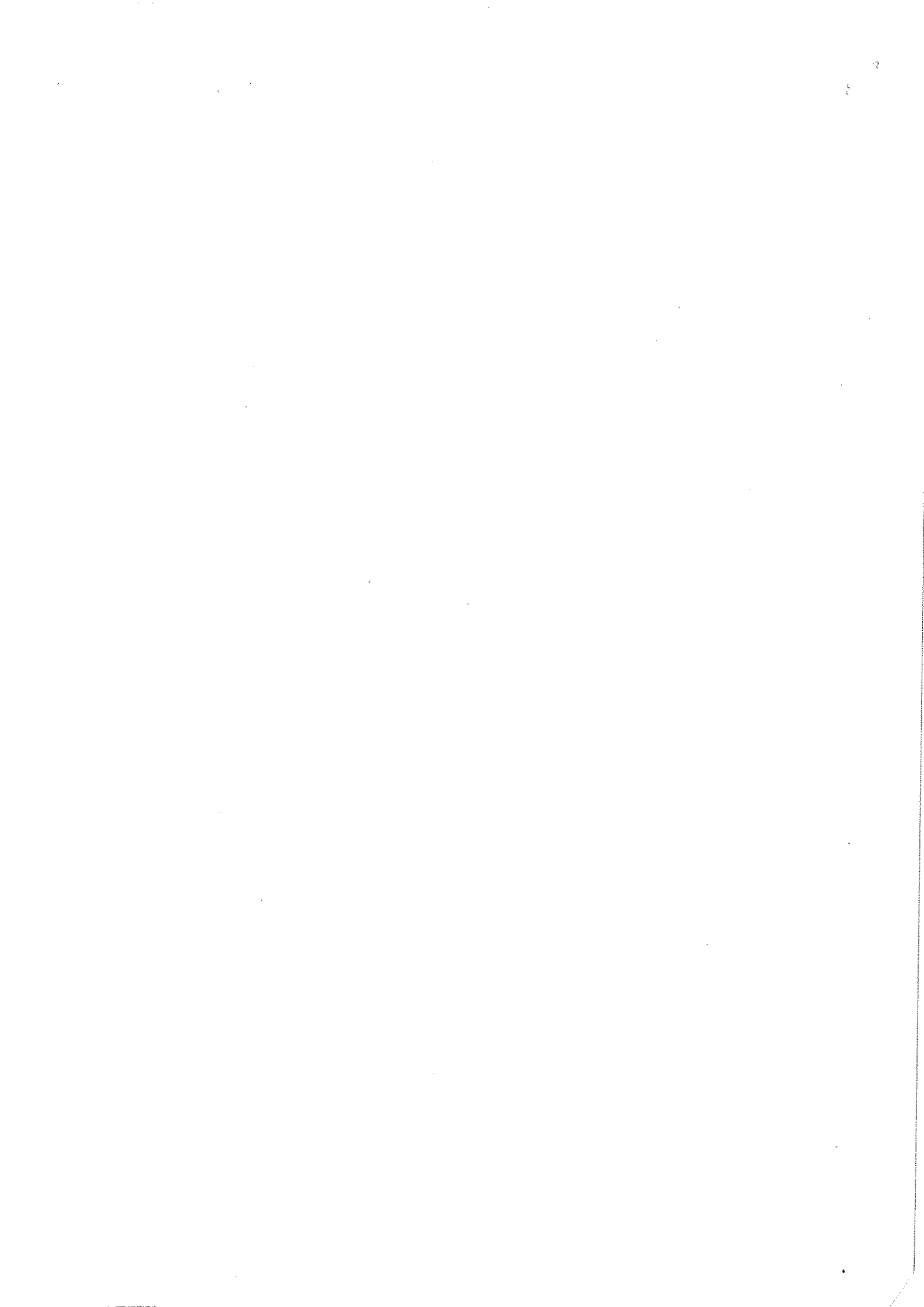



Registration No.:

BHARTIYA SKILL DEVELOPMENT UNIVERSITY

Q-7. What is the purpose of dry coat?

- a. To facilitate sanding
- b. To remove dust
- c. a & b
- d. None of the above

Q-8. Which paint is more environment friendly?

- a. NC Paints
- b. Synthetic paints
- c. Waterborne paint
- d. All of the above

Q-9. What is the baking temperature for 2k refinish paint?

- a. 45 degree Celsius
- b. 60 degree Celsius
- c. 90 degree Celsius
- d. 120 degree Celsius

Q-10. Which of the following paint layer is not a part of refinish painting?

- a. Electro Phosphating
- b. Epoxy primer
- c. Polyester putty
- d. Body filler

Section – B

04X04 = 16 Marks

Q-11. Draw Hue circle diagram with neat sketch.

Q-12. What is the difference between body filler and putty?

Q-13. Write down the SOP of Spot Repair?

Q-14. What is the difference between wash Primer and Surfacer?

Section – C

06X04 = 24 Marks

Q-15. What are the factors that influences the colors? Explain the cause.

Q-16. What are the causes of runs on the panel? Explain its precaution and remedies.

Q-17. Explain different types of paint defects and its prevention? (at least four)

Q-18. Discuss the correct parameters of spray gun handling during paint application.

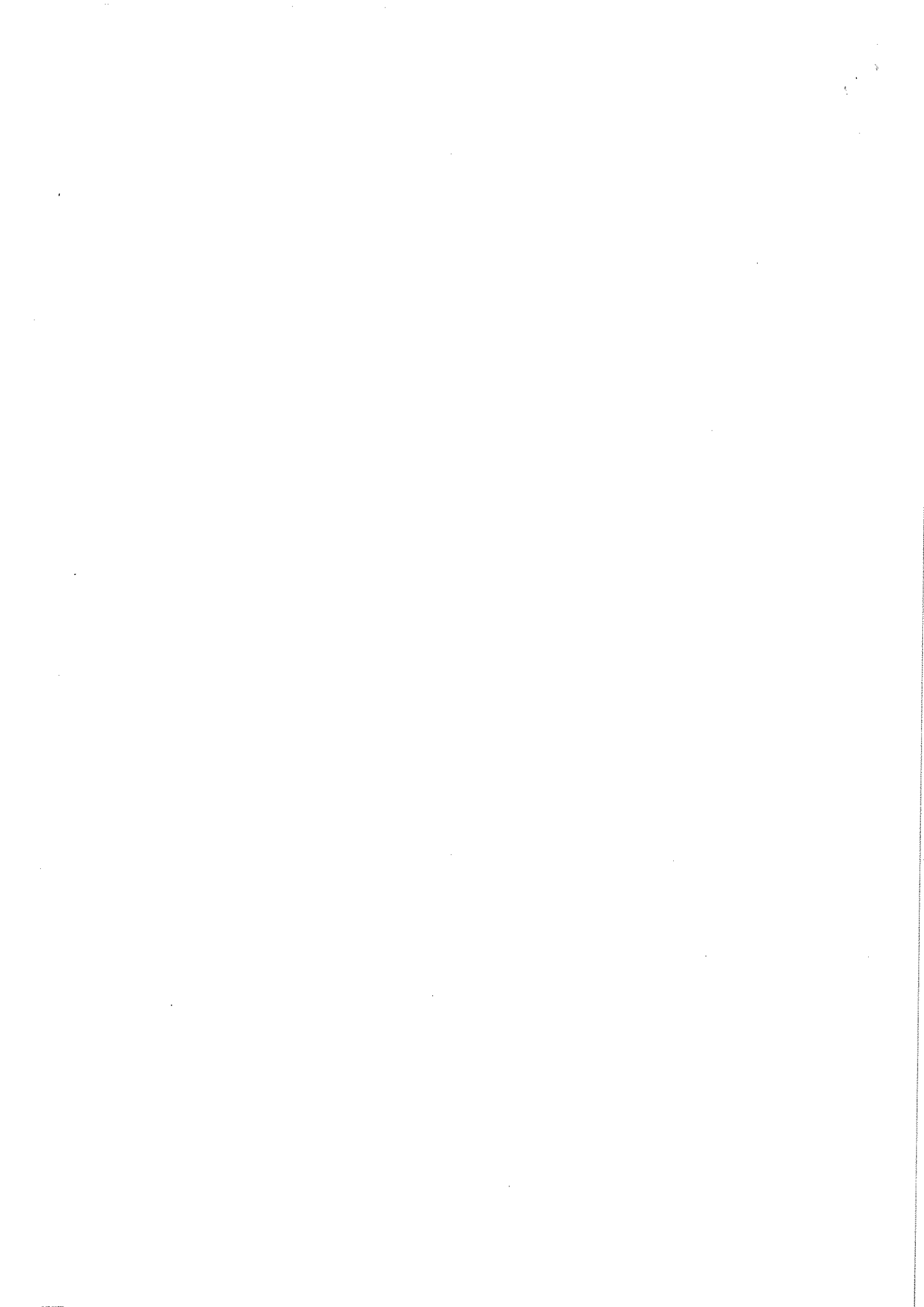



BHARTIYA SKILL DEVELOPMENT UNIVERSITY

School of Automotive Skills

Session: 2021-22 (Winter Semester)

B. Voc. Program, 3rd Semester,

End-Sem. Examination

Registration No.:

Set B - A.K

Course Code: AUT1304

Time: 2 Hour

Course Name: Automotive Refinish Painting

Max. Marks: 50 marks

Instruction:

1. Answer all questions from section A, each question carries one mark
2. Answer all question from section B, each question carries two mark.
3. Answer all question from section C, each question carries three mark.

Section – A

10X01 = 10 Marks

Q-1. What does 1-k represent?

- a. 1000
- b. **Product with hardener**
- c. Product without hardener
- d. None of these

Q-2. Dry Guide coat is used for.

- a. **Guide in sanding**
- b. Cleaning dirt
- c. Covering pores
- d. None of the above

Q-3. The appropriate light for color inspection is...

- a. **Sun light**
- b. Sodium light
- c. LED light
- d. All of the above

Q-4. What is the best way of removing the dust particles after putty dry sanding?

- a. Air blowing
- b. Cleaning with thinner
- c. Cleaning with degreaser
- d. **Both (a) and (c)**

Q-5. Which of the following are secondary colors?

- a. Red, blue & yellow
- b. **lime, orange & violet**
- c. Violet, green & blue
- d. Red, orange & blue

Q-6. What is the mixing ratio (in gram) of polyester putty & hardener?

- a. 100: 2
- b. 100:10
- c. 100:12
- d. **As per manufacturer**



Registration No.:

BHARTIYA SKILL DEVELOPMENT UNIVERSITY

Q-7. What is the purpose of 1K putty?

- a. Filling pores
- b. To remove dust
- c. a & b
- d. None of the above

Q-8. Which thinner is more convenient for cleaning HVLP GUN?

- a. A B 385
- b. 3920 S
- c. Prep Clean
- d. All of the above

Q-9. What is the baking temperature for 2k refinish paint?

- a. 45 degree Celsius
- b. 60 degree Celsius
- c. 90 degree Celsius
- d. 120 degree Celsius

Q-10. Which of the following paint layer is a part of OEM painting?

- a. Electro Phosphating
- b. Epoxy primer
- c. Polyester putty
- d. Body filler

Section – B

04X04 = 16 Marks

Q-6. Draw Hue circle diagram with neat sketch.

Ans.

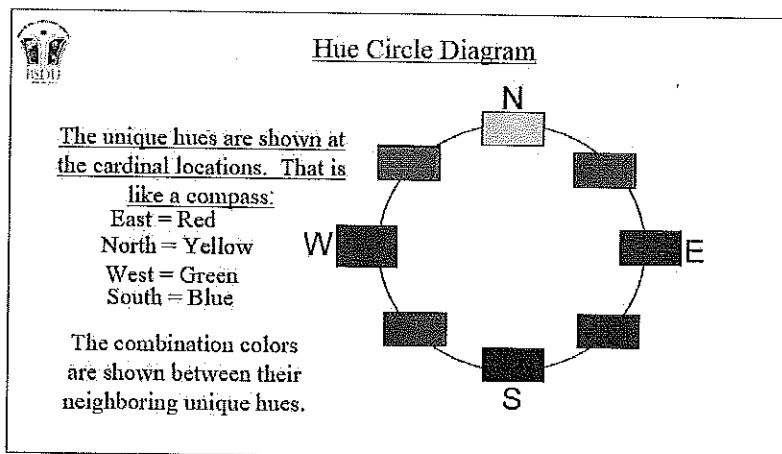

Q-7. What is the difference between body filler and putty?

Ans. Body filler is used when the size of dent is large because the density of body filler is lesser than the putty due to bigger grain size.

Putty is used to finish the layer of body filler and to fill the scratches and small dents as the density of putty is more than body filler due to smaller grain size.

Q-8. Write down the SOP of Standard Repair?

Ans.

Step 1: Pre-Cleaning

Step 2: Initial Prep Sand the spotted area with P320 and interface pad

Step 3: Mix and Apply Filler

Step 4: Sand Filler

Step 5: Mix and Apply PU Primer Surfacer

Step 6: Sand the Surfacer with Soft disc

Step 7: Mix the paint according to the required shade and apply on spot in one and half coat.

Step 8: Apply clear coat if Required

Q-9. What is the difference between Etch Primer and Primer Surfacer?

Ans. The wash primer is a specific type of primer designed to protect metal and allow good adhesion of paint. So when you are painting metal, it's essential to use this product to prevent the material itself from causing the paint to deteriorate and peel off. The wash primer is applied using a paint spray gun and the film thickness is usually 0.3-0.5 mils. The acid etches the metal surface and provides for good adhesion. A conversion coating is a slightly acidic aqueous solution (water-based) of chemicals.

Objects such as stainless steel and anodized parts should be sanded to loosen the anodized portion and promote adhesion of the wash primer. For anodized aluminum of architectural grade, the surface should be sanded using 40-80 grit sandpaper until the profile of the surface can be seen

Section – C

06X04 = 24 Marks

Q-9. What are the factors that influences the colors? Explain

Color influencing factors are:

Ans. Environment

- Product
- Application
- Equipment

Q-10. What are the causes in HVLP Gun for RUNs on the panel? Explain its precaution and remedies.

• Ans.

Causes:

- Incorrect spraying viscosity, spraying technique.

- Defective spray gun set up.
- Incorrect spraying pressure.
- Temperature of paint, substrate or spray booth too low.
- Incorrect choice of hardeners and thinners.

Prevention:-

- Ensure that the spray gun is in good working order.
- Warm object and material up to room temperature of 20 °C/68 °F.
- Use correct combination of hardeners and thinners .

Remedies:-

- Sand and polish.
- Sand and repaint.

Q-11. Explain different types of paint Application defects and its prevention? (at least four)

Ans. **Paint defect-** Any dissimilarity between the original paint and refinish paint work is considered to be a paint defect.

There are lot of paint defects like: -

- 1.runs
- 2.water spotting
- 3.clouding
- 4.bird droppings
- 5.solvent popping

Brief description of defects: -

1.Runs

Causes: -

- Incorrect spraying viscosity, spraying technique.
- Defective spray gun set up.
- Incorrect spraying pressure.
- Temperature of paint, substrate or spray booth too low.
- Incorrect choice of hardeners and thinners

Prevention: -

- Ensure that the spray gun is in good working order.
- Warm object and material up to room temperature of 20 °C/68 °F.
- Use correct combination of hardeners and thinners.
-

Remedies: -

- Sand and polish.
- Sand and repaint

2. water spotting

Causes: -

- Topcoat not sufficiently cured.
- Excessive film thickness, drying time too short.
- Use of unsuitable thinner.
- Incorrect hardener mixing ratio.
- Wrong hardener used

Prevention: -

- Follow application recommendations on technical data sheets

Remedies: -

- After through-drying, remove marks by polishing
- Thoroughly dry topcoat, sand and repaint

3. Clouding

Causes: -

- Incorrect spraying viscosity, spraying technique, flash-off times, spray booth temperature.
- Defective spray gun set up, incorrect spraying pressure.
- Use of unsuitable thinner.

Prevention: -

- Adjust material correctly.
- Keep spray gun parallel to object.
- Choose suitable spray gun set up.
- Use manufacturer's thinners.

Remedies: -

- When using conventional base coat: use droplet method before spraying clear.
- After clear has through-dried, sand surface and repaint.

4. sanding scratches

Causes: -

- Sanding paper too coarse.
- Filler sanded when soft.
- Insufficient sanded polyester stopper.
- Insufficient isolation of the stopper before topcoat application

Prevention: -

- Use recommended grade sanding paper.
- Isolate repaired areas with 2K filler.
- Dry filler thoroughly.

Remedies: -

- Thoroughly dry and sand.

Isolate or remove substrate, repaint

Q-12. Discuss the correct parameters of HVLP gun handling during paint application.

Ans.

- a. The angle of gun should be 90 degrees to the panel.
- b. The pressure of gun should be 2-3 bar.
- c. The distance between the panel and gun should be 5-8 inches.
- d. The discharge should be 2.5 rounds of the discharge knob.
- e. Overlapping should be 50% in each lap.



School of Automotive Skills
Session: 2021-22 (Winter Semester)
B. Voc. Program, 3rd Semester,
End-Sem. Examination

Course Code: AUT1305

Time: 2 Hours

Course Name: Automotive Electrical & AC.

Max. Marks: 50

Instruction:

1. Answer all questions from section A, each question carries one mark.
2. Answer all questions from section B, each question carries four mark.
3. Answer all questions from section C, each question carries six mark.

Section – A

10X01 = 10 Marks

Q. 1 The process of producing electric current through variable magnetic field is called:

- | | |
|--------------------|------------------------------|
| a. Patience | c. Parabolic |
| b. Electrification | d. Electromagnetic induction |

Q.2 Where is the expansion valve installed in automotive AC system?

- a. at the condenser inlet and outlet tubes
- b. at the evaporator inlet and condenser outlet
- c. between the evaporator outlet and the compressor inlet
- d. between the evaporator outlet and condenser inlet

Q.3 The charge on an electron is equal to:

- | | |
|--|--|
| a. 1.6×10^{-19} C of -ve charge | c. 1.6×10^{-22} C of -ve charge |
| b. 2.6×10^{-19} C of -ve charge | d. 1.6×10^{-23} C of -ve charge |

Q.4 Which of the following statement is always correct?

- a. An atom has equal number of electrons and protons
- b. An atom has equal number of electrons and neutrons
- c. An atom has equal number of protons and neutrons
- d. An atom has equal number of electrons, protons and neutrons

Q.5 Which of the given fuse is bigger.....

- | | |
|-------|-----------------------|
| a. DC | c. DC or AC |
| b. AC | d. AC and DC are same |

Q.6 A relay is used to:

- | | |
|---------------------------------------|--------------------|
| a. Break the fault current | c. Sense the fault |
| b. Sense the fault and direct to trip | d. All of these |

the circuit

Q.7 Basic relay connection requirements is that the relay must operate for

- | | |
|---------|--------------------|
| a. Load | b. Internal faults |
|---------|--------------------|



BHARTIYA SKILL DEVELOPMENT UNIVERSITY

c. Both a and b

d. None of these

Q.8 Electronic multimeter measures:

a. Voltage current and resistance

c. Voltage and current

b. Current and power

d. Energy and power

Q.9 Which is the most commonly use refrigerant ?

a. R134a

c. Alcohol

b. Water

d. Ethylene glycol

Q.10 .An unknown DC voltage is to be measured. Which measuring range in the multimeter will you select first?

a. 500 V

c. 5 V

b. 50 V

d. 0.5 V

Section – B

04X04 = 16 Marks

Q.1 What is transformer? Explain its function. Differentiate between step up transformer and step down transformer

Q.2 What is relay? Functions of a relay and types of relay used in automotive.

Q.3 Explain function and working of both an alternator and starter motor.

Q.4 Explain standard operating procedure of using multimeter and a multimeter can measure multiple electrical properties, name them.

Section – C

04X06 = 24 Marks

Q.1 Explain vapor compression refrigeration cycle along with various process involved in automotive vehicles with neat sketch.

Q.2 Explain principal of operation, construction and working of lead acid battery use in automotive vehicles.

Q.3 Write various electrical symbols used in automotive electrical systems along with its function.

Q.4 Explain with neat sketch various components system connecting in automotive vehicles (wiring diagram).



School of Automotive Skills
Session: 2021-22 (Winter Semester)
B. Voc. Program, 3rd Semester,
End-Sem. Examination

Set - A. Q.P.

Course Code: AUT1305

Time: 2 Hours

Course Name: Automotive Electrical & AC.

Max. Marks: 50

Instruction:

1. Answer all questions from section A, each question carries one mark.
2. Answer all questions from section B, each question carries four mark.
3. Answer all questions from section C, each question carries six mark.

Section – A

10X01 = 10 Marks

Q.1 An voltmeter is an electrical instrument used to measure:

- | | |
|------------|----------------------|
| a. Current | c. Resistance |
| b. Voltage | d. None of the above |

Q.2 The unit of electrical current is the:

- | | |
|-----------|------------|
| a. Volt | c. Joule |
| b. Ampere | d. Coulomb |

Q.3 Current flows in a circuit when:

- | | |
|-----------------------|--|
| a. A switch is opened | c. The switch is either open or closed |
| b. A switch is closed | d. There is no voltage |

Q.4 With Ohm's law, if current increases and resistance stays the same:

- | | |
|-----------------------------|-------------------------|
| a. Current remains the same | c. Current increases |
| b. Power decreases | d. Resistance decreases |

Q.5 A transformer transform:

- | | |
|------------|-----------------|
| a. Current | c. Frequency |
| b. Voltage | d. Both A and B |

Q.6 The process of producing electric current through the variable magnetic field is called:

- | | |
|--------------------|------------------------------|
| a. Electrification | c. Electromagnetic induction |
| b. patience | d. Parabolic |

Q.7 The capacity of a battery is expressed in terms of:

- | | |
|-------------------|-----------------------|
| a. Current rating | c. Ampere hour rating |
| b. Voltage rating | d. None of the above |

Q.8 The direction of the arrow represents the direction of When the diode is forward biased?

- | | |
|--------------------|------------------------------|
| a. P-type material | c. P-N Junction |
| b. N-type material | d. Conventional current flow |



BHARTIYA SKILL DEVELOPMENT UNIVERSITY

Q.9 Which is the most commonly use refrigerant in AC ?

- a. R134a
- b. Water
- c. Alcohol
- d. Ethylene glycol

Q.10. The function of a compressor is:

- a. To compress the water
- b. To compress the refrigerant
- c. To compress the air
- d. None of the above

Section – B

04X04 = 16 Marks

Q.1 What is diode, rectifiers and transistors? explain its function.

Q.2 Explain electromagnetism with neat diagram.

Q.3 What is current and voltage? Write down properties of current and voltage.

Q.4 Draw with neat diagram series and parallel connections of a resistor.

Section – C

04X06 = 24 Marks

Q. 1 Explain construction, and working of lead acid battery.

Q. 2 Write down the four main components used in vehicle AC system also write down the function of each components in brief.

Q. 3 Explain the structure of an atom with neat sketch.

Q.4 There are two resistors R_1 and R_2 having resistance equal to 40Ω and 60Ω respectively are connected in parallel in an electric circuit. If the potential difference/voltage across the electric circuit is 12 V, find the electric current flowing through the circuit and the total resistance of the resistors.



School of Automotive Skills
Session: 2021-22 (Winter Semester)
B. Voc. Program, 3rd Semester,
End-Sem. Examination

Course Code: AUT1305

Time: 2 Hours

Course Name: Automotive Electrical & A.C.

Max. Marks: 50

Instruction:

1. Attempt all the questions.
2. Draw neat and clean diagram.

Section – A

10X01 = 10 Marks

1. c
2. b
3. c
4. c
5. b
6. a
7. a
8. b
9. c
10. d

Section – B

04X04 = 16 Marks

1. A **diode** is a two-terminal electronic component that conducts current primarily in one direction (asymmetric conductance); it has low (ideally zero) resistance in one direction, and high (ideally infinite) resistance in the other.

A **rectifier** is an electrical device that converts alternating current (AC), which periodically reverses direction, to direct current (DC), which flows in only one direction. The reverse operation is performed by the inverter.

Transformers are electrical devices consisting of two or more coils of wire used to transfer electrical energy by means of a changing magnetic field. Function of a transformer is to transform alternating current energy from one voltage to another voltage.

2. It is a basic law of electromagnetism predicting how a magnetic field will interact with an electric circuit to produce an electromotive force (EMF). This phenomenon is known as electromagnetic induction.



BHARTIYA SKILL DEVELOPMENT UNIVERSITY

3. An **electric current** is a stream of charged particles, such as electrons or ions, moving through an electrical conductor or space. **Voltage** is the pressure from an electrical circuit's power source that pushes charged electrons (current) through a conducting loop, enabling them to do work such as illuminating a light. Piezoelectric Effect is the ability of certain materials to generate an electric charge in response to applied mechanical stress.

4. Series and Parallel connection

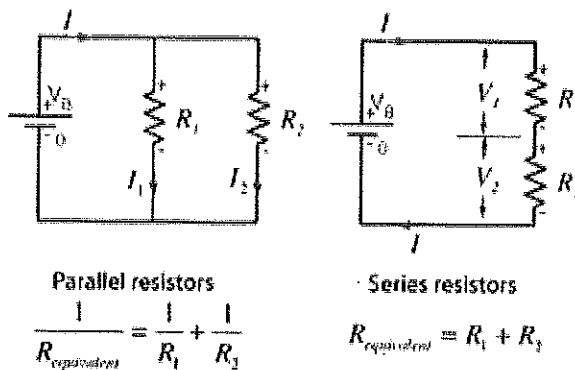

Section – C

04X06 = 24 Marks

1. Principal and working: When the sulfuric acid dissolves, its molecules break up into positive hydrogen ions ($2H^+$) and sulphate negative ions (SO_4^-) and move freely. ... The SO_4^- ions being negatively charged moved towards the electrodes connected to the positive terminal of the supply main (i.e., anode).

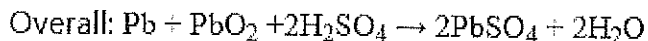
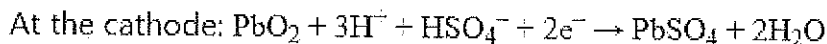
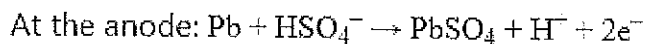

2. The four main components of AC is compressor, condenser, evaporator and expansion valve.
3. Structure of an atom

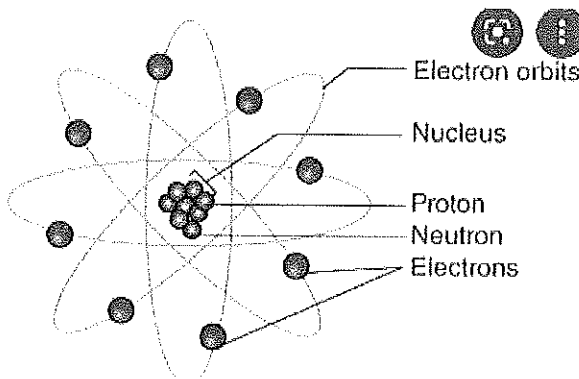

The Structure of Atom



Q4 Resistance numerical

Total resistance (R) =?

Electric current (I) through the circuit =?

We know that in parallel combination, the reciprocal of total resistance is,

$$\begin{aligned}\frac{1}{R} &= \frac{1}{R_1} + \frac{1}{R_2} \\ &= \frac{1}{20\Omega} + \frac{1}{30\Omega} \\ &= \frac{3 + 2}{60} \Omega = \frac{5}{60} \Omega\end{aligned}$$

$$\text{Or, } \frac{1}{R} = \frac{1}{12} \Omega$$

Now, electric current through the circuit $I = \frac{V}{R}$

$$\text{Or, } I = 5V \div 12\Omega = 0.416A$$

Thus, total resistance $R = 12\Omega$

Electric current (I) through the circuit = 0.416 A



School of Automotive Skills
Session: 2021-22 (Winter Semester)
B. Voc. Program, 3rd Semester,
End-Sem. Examination

Answer key

Course Code: AUT1305

Time: 2 Hours

Course Name: Automotive Electrical & A.C.

Max. Marks: 50

Instruction:

1. Attempt all the questions.
2. Draw neat and clean diagram.

Section – A

10X01 = 10 Marks

1. c
2. b
3. c
4. c
5. b
6. a
7. a
8. b
9. c
10. d

Section – B

04X04 = 16 Marks

1. Transformers are electrical devices consisting of two or more coils of wire used to transfer electrical energy by means of a changing magnetic field. Function of a transformer is to transform alternating current energy from one voltage to another voltage.

BASIS FOR COMPARISON	STEP-UP TRANSFORMER	STEP-DOWN TRANSFORMER
Definition	Step-up transformer increase the output voltage.	Step-down transformer reduces the output voltage.
Voltage	Input voltage is low while the output voltage is high.	Input voltage is high while the output voltage is low.
Winding	High voltage winding is the secondary winding.	High voltage winding is the primary winding.
Current	Current is low on the secondary winding.	Current is high on the secondary winding.
Rating of output voltage	11000 volts or above	110v, 24v, 20v, 10v, etc.
Size of the conductor	Primary winding is made up of thick insulated copper wire.	Secondary winding is made up of thick insulated copper wire
Application	Power plant, X-rays	Doorbell, voltage

2. It is a basic law of electromagnetism predicting how a magnetic field will interact with an electric circuit to produce an electromotive force (EMF). This phenomenon is known as electromagnetic induction.
3. An alternator is an electrical machine. Its function is to charge the battery on a regular basis. However, if the battery is dead, the alternator cannot charge it. It regulates voltage and supplies power used to operate the car. The electricity used by various parts of the car is generated by the alternator; not by the battery which we usually believe.
The starter is an electric motor placed on the side of the engine. Bendix Mechanism is used here. This automatically allows the pinion gear to engage the flywheel of the engine. Starter rotates and starts the engine. The name actually suits best as the starter sounds exactly what it does. It starts the car.
4. A multimeter can be measure current, voltage, resistance, capacitance, inductance etc.

Section – C

04X06 = 24 Marks

1. VCRS:

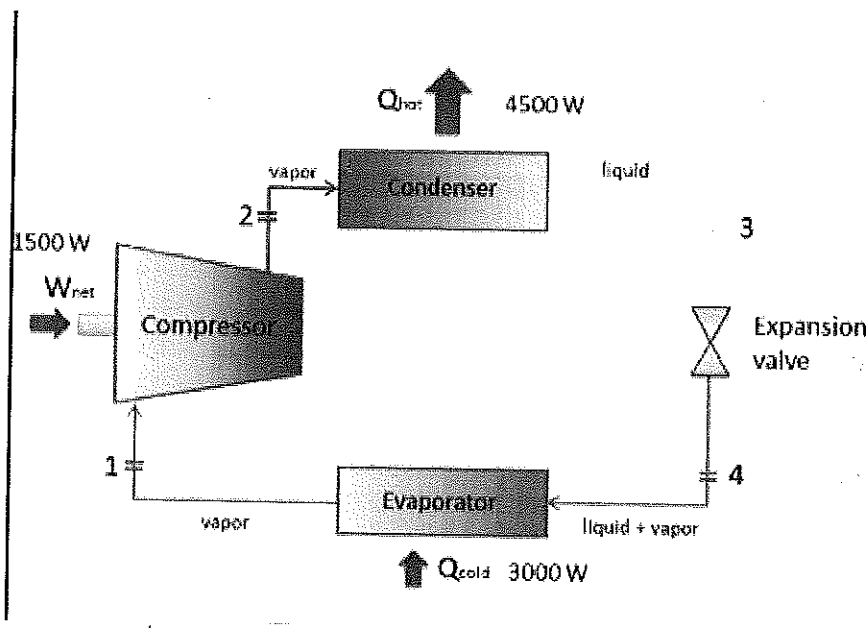

2. Principal Construction and working: When the sulfuric acid dissolves, its molecules break up into positive hydrogen ions ($2H^+$) and sulphate negative ions (SO_4^-) and move freely. ... The SO_4^- ions being negatively charged moved towards the electrodes connected to the positive terminal of the supply main (i.e., anode).

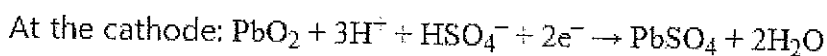

3. Electricals symbols



BHARTIYA SKILL DEVELOPMENT UNIVERSITY

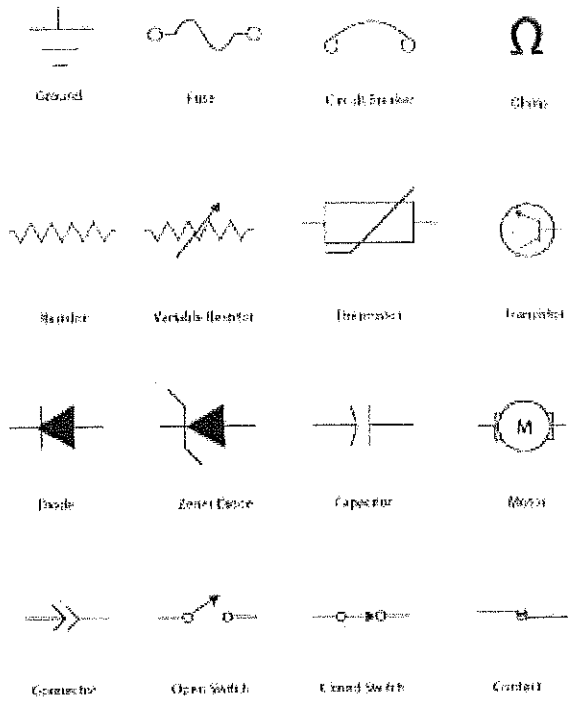

4. Wiring diagram:

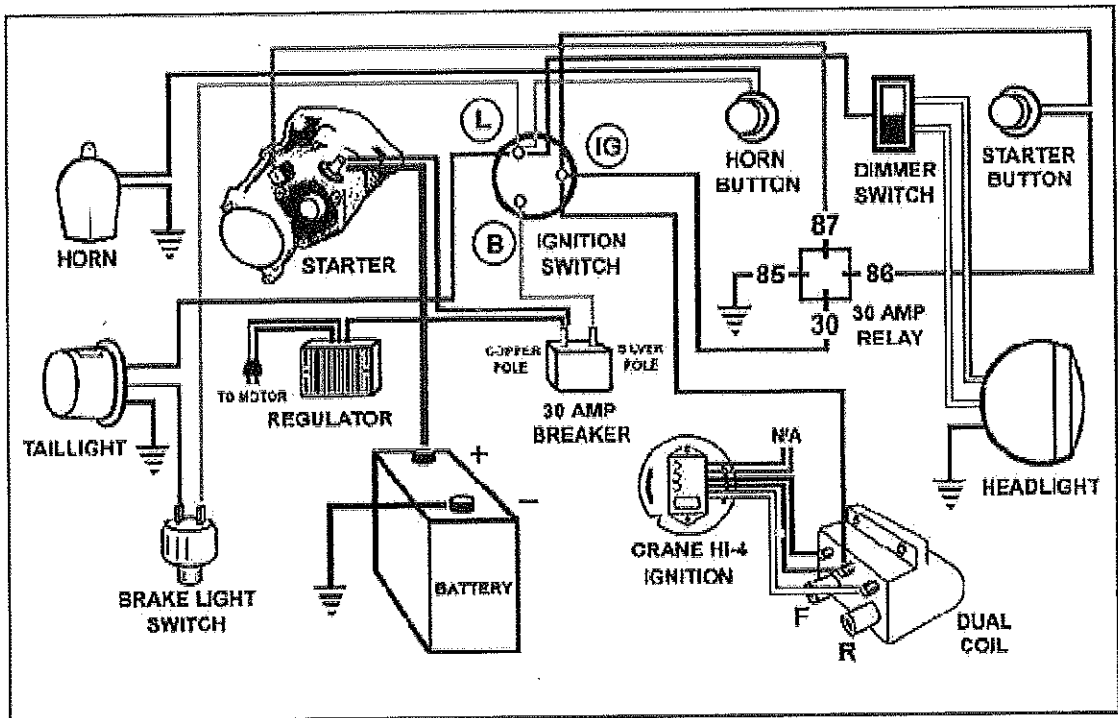

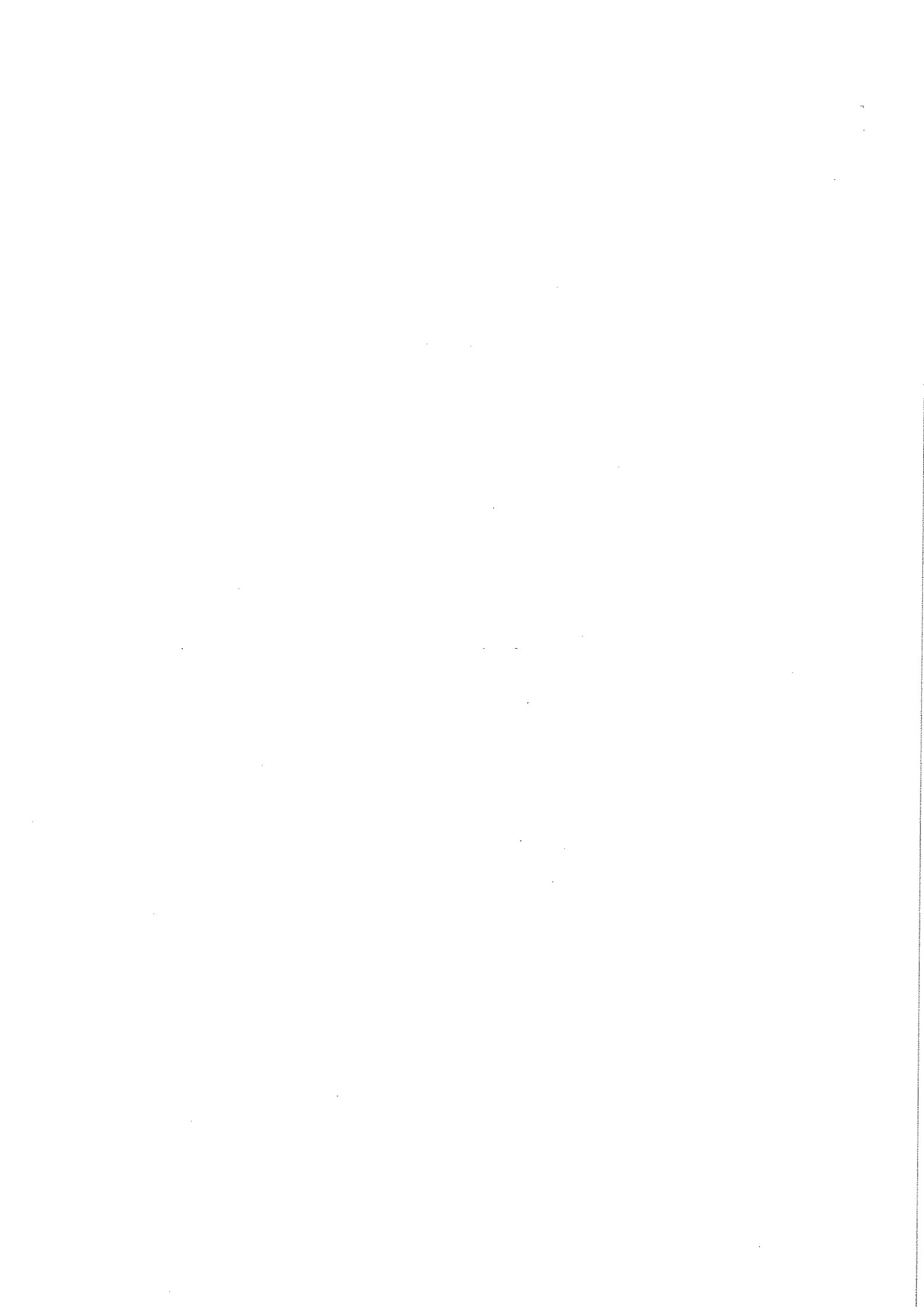



School of General Education
Session: 2021-22 (Winter Semester)
B. Voc. Program, 3rd Semester,
End-Sem. Examination

Course Code: GEN1308

Time: 2 Hours

Course Name: Basics of AutoCAD & SolidWorks

Max. Marks: 50

Instruction:

1. Answer all questions from section A, each question carries one mark.
2. Answer all question from section B, each question carries four marks.
3. Answer all question from section C, each question carries six marks.

Section – A

10X01 = 10 Marks

Q1. "Xrefs" command is used to:

- A. Import small drawings for reference.
- B. Import data from saved files.
- C. Import large drawings for reference.
- D. None of the above.

Q2. By which of the following command, you can draw a rectangle in AutoCAD?

- A. ARC.
- B. POL.
- C. REC.
- D. CO.

Q3. _____ key automatically activates the O snap feature of AutoCAD.

- A. F1.
- B. F2.
- C. F3.
- D. F4.

Q4. To obtain parallel lines, concentric circles and parallel curves _____ is used.

- A. Copy.
- B. Fillet.
- C. Offset.
- D. None of the above.

Q5. Which of the following command in AutoCAD is used to create multiple viewports in the layout?

- A. EATTEDIT.
- B. VPORTS.
- C. QSELECT.
- D. GROUP.

Q6. What is the command to create a sphere in AutoCAD?

- A. S.
- B. Spe.
- C. Sh.
- D. Sphere.

Q7. In _____ option you will create base of the cylinder by specifying three points.

- A. 1P.
- B. 3P.
- C. 2P.
- D. None of the above.



Q8. What is the file format for SolidWorks Part file?

- A. .sldfpt
- B. .sldprt
- C. .ftsdot
- D. .asmdot

Q9. Which sketch relation can you NOT apply to a rectangle?

- A. Coincident.
- B. Collinear.
- C. Fix.
- D. Concentric.

Q10. What is required to create a new 2D sketch?

- A. Any existing geometry.
- B. Any existing plane or curved face.
- C. Any existing plane or planar face.
- D. Any planar or curved surface.

Section – B

04X04 = 16 Marks

Q11. List out the major difference between the AutoCAD and SolidWorks?

Q12. List out the major or basic components of FeatureManager design tree?

Q13. What do you understand by parametric constraints in AutoCAD?

Q14. Explain Cylinder command in detail with a suitable drawing.

Section – C

04X06 = 24 Marks

Q15. Explain Solid Primitives of AutoCAD 3D?

Q16. Mention what does SolidWorks Utilities provides?

Q17. Explain the role & responsibilities of an AutoCAD designer.

Q18. Explain the following commands:

- a. Sweep.
- b. Intersect.
- c. Interfere.