



BHARTIYA SKILL DEVELOPMENT UNIVERSITY

Registration No.:

School of Automotive Skills
 Session: 2021-22 (summer semester)
 B. Voc. Program, Vth Semester,
 End-Sem. Examination

Course Code: AUT 1501

Time: 2 Hours

Course Name: AUTOMOTIVE MECHATRONICS SYSTEM

Max. Marks: 50

Instruction:

1. Non Programmable Scientific Calculators are permitted.
2. Any assumptions made in attempt of questions may be mentioned.
3. All questions are compulsory.

Section – A

10X01 = 10 Marks

1. By atomizing the fuel into very fine droplets, it _____ the surface area of the fuel droplets.

(a) Increases	(b) Decreases
(c) unpredictable	(d) None of the Mentioned
2. Which of the following does not depend on fuel quantity injected?

(a) System pressure	(b) Duration of Injection
(c) Size and shape of Nozzle	(d) Alternator
3. Proximity sensors are used to :

(a) Detect Non-Magnetic but conductive Materials	(b) Measure strain
(c) Measure Distance	(d) Both (b) & (c)
4. Which of the following is not component of Common Rail fuel Injection system?

(a) ECU	(b) Injector
(c) Spark Plug	(d) Electric fuel pump
5. _____ is done by forcing the fuel through a small orifice under high pressure.

(a) Vacuum	(b) Atomization
(c) Carburation	(d) None of the mentioned
6. What is the function of Pump in an automatic brake system?

(a) For fault detection	(b) To sense the speed of the Vehicle
(c) To restore Pressure	(d) To calculate the Acceleration and deceleration



BHARTIYA SKILL DEVELOPMENT UNIVERSITY

7. The TCS gets activated when throttle input and engine torque are mismatched to road surface conditions:
- (a) True (b) None of the above
(c) Incomplete information (d) false
8. In multiple injections in CRDI the Pre/ Pilot Injections lead to.....
- (a) Reduce emissions (b) Reduce NOx
(c) Reduce noise (d) Reduce noise & NOx
9. The main function of exhaust muffler is :
- (a) optimization of exhaust efficiency (b) Reduction of exhaust noise
(c) Reduction of NOx in exhaust (d) none of the above
10. Hill descent control is a.....
- (a) Safety function (b) Comfort function
(c) Navigation function (d) Convenience function

Section – B

04X04 = 16 Marks

11. Explain function of rail in CRDI system.
12. Explain fuel temperature sensor with principle and construction.
13. Define sensors and actuators with examples.
14. Explain rail pressure sensor regulating valve with diagram.

Section – C

04X06 = 24 Marks

15. Explain ABS and ESP in Braking system.
16. Explain coolant temperature sensor.
17. Explain modules in mechatronic system.
18. Explain Micromechanical pressure sensor with construction with Application and principle?



BHARTIYA SKILL DEVELOPMENT UNIVERSITY

Registration No.:

School of Automotive Skills
 Session: 2021-22 (winter semester)
 B. Voc. Program, Vth Semester,
 End-Sem. Examination

Course Code: AUT 1501

Time: 2 Hours

Course Name: AUTOMOTIVE MECHATRONICS SYSTEM

Max. Marks: 50

Instruction:

1. Non Programmable Scientific Calculators are permitted.
2. Any assumptions made in attempt of questions may be mentioned.
3. All questions are compulsory.

Section – A

10X01 = 10 Marks

1. By atomizing the fuel into very fine droplets, it _____ the surface area of the fuel droplets.
- (a) Increases (b) Decreases
 (c) unpredictable (d) None of the Mentioned

Ans-a

2. Which of the following does not depend on fuel quantity injected?
- (a) System pressure (b) Duration of Injection
 (c) Size and shape of Nozzle (d) Alternator

Ans-d

3. Proximity sensors are used to :
- (a) Detect Non-Magnetic but conductive Materials (b) Measure strain
 (c) Measure Distance (d) Both (b) & (c)

Ans -c

4. Which of the following is not component of Common Rail fuel Injection system?
- (a) ECU (b) Injector
 (c) Spark Plug (d) Electric fuel pump

Ans -c

5. _____ is done by forcing the fuel through a small orifice under high pressure.
- (a) Vacuum (b) Atomization
 (c) Carburation (d) None of the mentioned

Ans-b

6. What is the function of Pump in an automatic brake system?



BHARTIYA SKILL DEVELOPMENT UNIVERSITY

- (a) For fault detection
(b) To sense the speed of the Vehicle
(c) To restore Pressure
(d) To calculate the Acceleration and deceleration

Ans: c

7. The TCS gets activated when throttle input and engine torque are mismatched to road surface conditions:

TRUE/FALSE

Ans: True

8. In multiple injections in CRDI the Pre/ Pilot Injections lead to.....

- (a) Reduce emissions
(b) Reduce NOx
(c) Reduce noise
(d) Reduce noise & NOx

Ans: d

9. The main function of exhaust muffler is?

- (a) optimization of exhaust efficiency
(b) Reduction of exhaust noise
(c) Reduction of NOx in exhaust
(d) none of then above

Ans: b

10. Hill descent control is a.....

- (a) Safety function
(b) Comfort function
(c) Navigation function
(d) Convenience function

Ans: a

Section – B

04X04 = 16 Marks

11. Explain function of rail in CRDI system.

Ans: A common rail is one of the most important components in a diesel and gasoline direct injection system. The main difference between a direct and a standard injection is the delivery of fuel and the way how this one mixes with incoming air. In the direct injection system, the fuel is directly injected into the combustion chamber, skipping the waiting period in the air intake manifold. Controlled by the electronic unit, the fuel is squirted directly where the combustion chamber is hottest, which makes it burn more evenly and thoroughly.

12. Explain fuel temperature sensor with principle and construction?

Ans: Location-

- The fuel temperature sensor is located on the right at the high-pressure pump.

Task-



BHARTIYA SKILL DEVELOPMENT UNIVERSITY

It detects the temperature of the fuel flowing in the high pressure pump and passes this information onto the CDI control unit.

Function-

- The NTC measuring resistor alters its electrical resistance in line with the fuel temperature. The electrical resistance decreases as the fuel temperature rises.
- If the fuel delivered to the common rail high pressure pump goes above 90 degree C, the injection quantity and rail pressure are automatically reduced
- This causes the fuel less to be less compressed.

13. Define sensors and actuators with examples.

Ans: A sensor is a device that detects and responds to some type of input from the physical environment.

-An actuator is a part of a device or machine that helps it to achieve physical movements by converting energy, often electrical, air, or hydraulic, into mechanical force. it is the component in any machine that enables movement.

14. Explain rail pressure sensor regulating valve with diagram?

Ans: Location

- The rail pressure sensor is screwed into the right rail at the rear.

Task

- The rail pressure sensor is used to detect the current rail pressure and send it to the CDI control unit.

Function

- The rail pressure applied influences the location of a membrane which is fitted with a sensor element.
- A change in the location of a membrane alters the electrical resistance of the sensor element
- This change in resistance causes a voltage signal which is evaluated by the CDI control unit to detect pressure



BHARTIYA SKILL DEVELOPMENT UNIVERSITY

BSU Explain ABS and ESP in Braking system?

- Ans: **ABS**-In a vehicle, wheel speed sensors are located on the wheels that monitor the speed of each wheel. The electronic control unit (ECU) reads the signal from each sensor. After the speed sensors detect that the speed of any of the wheel(s) is reducing drastically compared to others, the ECU sends the signal to the valves of the respective wheel(s) to reduce the brake pressure, and the valves get closed.
- After this, the wheels start to accelerate again, and the signal is sent to the ECU one more time, which in turn sends the signal to open the valve and increase the brake pressure, and hence, brakes are applied.
- The cycle repeats itself until the application of brakes becomes normal.

ESP- that improves a vehicle's stability by detecting and reducing loss of traction (skidding). When ESC detects loss of steering control, it automatically applies the brakes to help steer the vehicle where the driver intends to go. Braking is automatically applied to wheels individually, such as the outer front wheel to counter oversteer, or the inner rear wheel to counter understeer. Some ESC systems also reduce engine power until control is regained. ESC does not improve a vehicle's cornering performance; instead, it helps reduce the chance of the driver losing control of the vehicle.

16. Explain coolant temperature sensor.

Ans: coolant temperature sensor is used to measure the temperature of the coolant in the cooling system, giving an indication of how much heat the engine is giving off.

Consist of thermistor and Works on NTC principle as the temperature increases resistance decreases The normal value of the sensor voltage is 2V at cold engine and 0.5V at warm engine

17. Explain modules in mechatronic system.

Ans: 1. Sensing

I. Sensors

II. Signal Conditioning

III. Analog-to-Digital and Digital-to-Analog Conversion

2. Control

I. Open Loop and Closed Loop Control

3. Action

18. Explain Micromechanical pressure sensor with construction, Application and principle?

Ans: **Function-** Micromechanical pressure sensors determine the absolute pressure of liquids and gases by measuring the pressure differential in relation to a reference vacuum.

Principle- diaphragm of the sensor cell is deflected to varying degrees depending on the voltages across them. This leads to a change in the measurement voltage U_M . This as yet unamplified voltage is therefore a measure of the pressure applied to the diaphragm.

Application- Intake-manifold pressure, e.g. for load sensing in engine-management systems.

- Boost pressure for boost-pressure control Ambient pressure for taking into account air density, e.g. in boost-pressure control .
- Oil pressure to take engine load into account in the service display.
- Fuel pressure for monitoring the level of fuel-filter contamination.

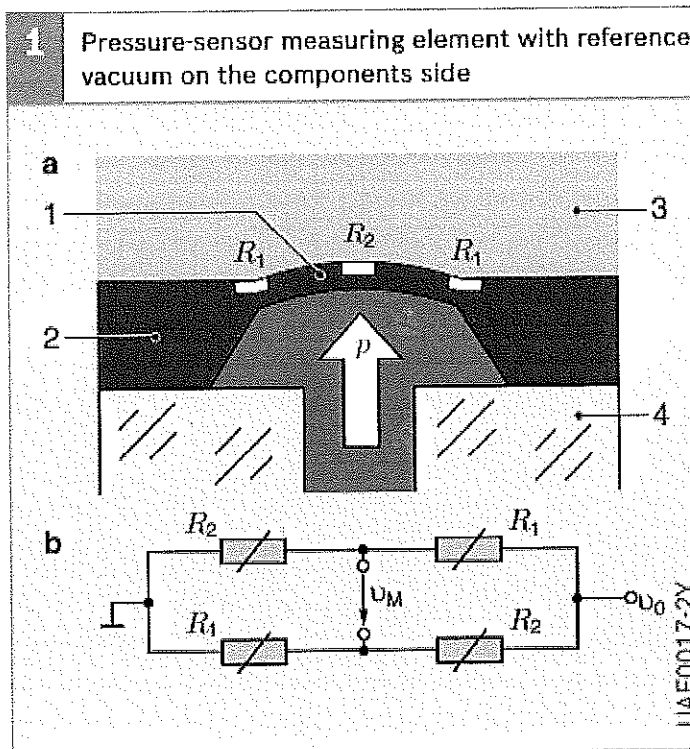



BHARTIYA SKILL DEVELOPMENT UNIVERSITY

Registration No.:

School of Automotive Skills
 Session: 2021-22 (Winter semester)
 B. Voc. Program, Vth Semester,
 End-Sem. Examination

Course Code: AUT 1501

Time: 2 Hours

Course Name: AUTOMOTIVE MECHATRONICS SYSTEM

Max. Marks: 50

Instruction:

1. Non Programmable Scientific Calculators are permitted.
2. Any assumptions made in attempt of questions may be mentioned.
3. All questions are compulsory.

Section – A

10X01 = 10 Marks

1. Catalytic converters are chambers mounted in the flow system through which the exhaust gas passes?

- | | |
|----------------------------|---------------------------|
| (a) True | (b) False |
| (c) Incomplete information | (d) None of the mentioned |

2. What is the function of an Anti-lock braking system?

- | | |
|----------------------------|--------------------------------|
| (a) Used for car parking | (b) To maintain Tractive force |
| (c) Programming the system | (d) To Drive the car |

3. The main function of Actuator is?:

- | | |
|-----------------------|------------------------------------|
| (a) To produce motion | (b) Detect input |
| (c) Detect output | (d) Detect the state of the system |

3. What is the function of an input signal conditioning unit?

- | | |
|--------------------------------|--|
| (a) To produce control signals | (b) To amplify the signal and convert it into digital form |
| (c) To perform mechanical work | (d) To produce electrical signals |

5. The Anti-lock braking brake system supports electronic stability.

- | | |
|-----------|-----------------------|
| (a) True | (c) Maybe (a) |
| (b) False | (d) None of the above |

6. What is the function of the ECU in Anti-lock braking system?

- | | |
|---|-------------------------------------|
| (a) Monitoring the speed of the vehicle | (b) Decreases the stopping distance |
| (c) Provides electronic stability | (d) maintaining tractive force |



BHARTIYA SKILL DEVELOPMENT UNIVERSITY

7. Thermocouples are active transducers?

- (a) True
- (b) False
- (c) Maybe (a)
- (d) None of the above

8. A transducer is basically a device which converts ?

- (a) Mechanical energy to electrical
- (b) Energy or information from one form
- (c) Mechanical displacement into electrical
- (d) none of the above

9. The main function of exhaust muffler is?

- (a) optimization of exhaust efficiency
- (b) Reduction of exhaust noise
- (c) Reduction of NOx in exhaust
- (d) none of the above

10. Hill descent control is a.....

- (a) Safety function
- (b) Comfort function
- (c) Navigation function
- (d) Convenience function

Section – B

04X04 = 16 Marks

11. what are the benefits of piezo injectors?

12. Explain Quantity Control Valve.

13. What is Negative temperature coefficient? and Positive temperature coefficient?

14. Explain wheel speed sensor.

Section – C

04X06 = 24 Marks

15. Explain Lambda oxygen sensor with construction.

16. Explain with construction knock sensor also symptoms of failure.

17. Explain types and working of Catalytic converter.

18. Explain Micromechanical pressure sensor with construction with Application and principle.



BHARTIYA SKILL DEVELOPMENT UNIVERSITY

Registration No.:

School of Automotive Skills
 Session: 2021-22 (summer semester)
 B. Voc. Program, Vth Semester,
 End-Sem. Examination

Course Code: AUT 1501

Time: 2 Hours

Course Name: AUTOMOTIVE MECHATRONICS SYSTEM

Max. Marks: 50

Instruction:

1. Non Programmable Scientific Calculators are permitted.
2. Any assumptions made in attempt of questions may be mentioned.
3. All questions are compulsory.

Section – A

10X01 = 10 Marks

1. Catalytic converters are chambers mounted in the flow system through which the exhaust gas passes?

- | | |
|----------------------------|---------------------------|
| (a) True | (b) False |
| (c) Incomplete information | (d) None of the mentioned |

Ans- a

2. What is the function of an Anti-lock braking system?

- | | |
|----------------------------|--------------------------------|
| (a) Used for car parking | (b) To maintain Tractive force |
| (c) Programming the system | (d) To Drive the car |

Ans- b

3. The main function of Actuator is?:

- | | |
|-----------------------|------------------------------------|
| (a) To produce motion | (b) Detect input |
| (c) Detect output | (d) Detect the state of the system |

Ans -a

3. What is the function of an input signal conditioning unit?

- | | |
|--------------------------------|--|
| (a) To produce control signals | (b) To amplify the signal and convert it into digital form |
| (c) To perform mechanical work | (d) To produce electrical signals |

Ans: b

5. The Anti-lock braking brake system supports electronic stability.

- (a) True
- (b) False

Ans: a



BHARTIYA SKILL DEVELOPMENT UNIVERSITY

6. What is the function of the ECU in Anti-lock braking system?

- (a) Monitoring the speed of the vehicle
- (b) Decreases the stopping distance
- (c) Provides electronic stability
- (d) maintaining tractive force

Ans: a

7. Thermocouples are active transducers?

TRUE/FALSE

Ans: True

8. A transducer is basically a device which converts ?

- (a) Mechanical energy to electrical
- (b) Energy or information from one form To another
- (c) Mechanical displacement into electrical
- (d) none of the above

Ans: b

9. The main function of exhaust muffler is?

- (a) optimization of exhaust efficiency
- (b) Reduction of exhaust noise
- (c) Reduction of NOx in exhaust
- (d) none of then above

Ans: b

10. Hill descent control is a.....

- (a) Safety function
- (b) Comfort function
- (c) Navigation function
- (d) Convenience function

Ans: a

Section – B

04X04 = 16 Marks

11. what are the benefits of piezo injectors?

Ans- The greatest advantage of Piezo injectors is the rate and precision in which fuel can be delivered, since the actuator can be rapidly activated and deactivated. Piezo injectors are also known for their superior reliability. The result is increased longevity, durability, efficiency, and reduced emissions.

12. Explain Quantity control Valve with construction?

Ans: **Location**

The quantity control valve is located on the high pressure pump flange for the high pressure.



Function

The fuel delivered by the fuel pump with fuel level sensor (M3) passes into the high-pressure pump flange and passed from there through the fuel temperature sensor (B50) to the flow control valve and to the fuel pressure relief valve. The quantity control valve controls the fuel amount according to the signal from the CDI control unit which is led to the 3 pump elements via an annular passage.

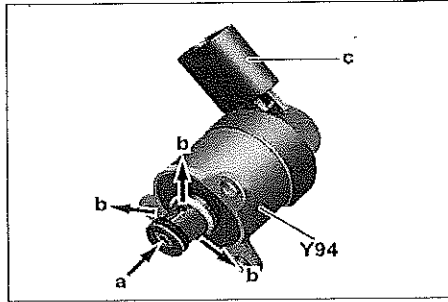

Y94 Quantity control valve

a Fuel feed (fuel from the fuel tank)

b Controlled fuel quantity (to the pump elements of the high pressure pump)

c Electrical connection

Task

The high pressure pump has the following tasks:

- Regulation of the fuel feed to the pump elements on the high pressure pump
- Interruption of fuel supply to the pump element on the high pressure pump by switching off the engine
- Regulation of the rail pressure in co-operation with the pressure regulator valve (Y74), rail pressure sensor (B4/6) and CDI control unit (N3/9)

13. What is Negative temperature coefficient and Positive temperature coefficient ?

Ans- in Negative temperature coefficient the resistance will decrease as the temperature increases.

In Positive temperature coefficient the resistance increase as the temperature increases.

14. Explain wheel speed sensor.

Ans - •Wheel speed sensors and how we test them have been changing. Currently, two types of wheel speed sensors are in use: magnetic inductive (passive) and magneto resistive (active).

•Passive sensors have been around since the early days of the anti-lock brake system (ABS). These are the sensors that function on the generator principle.

•The sensors work with the toothed tone wheels to monitor and provide the anti-lock brake module (ABM) with wheel speed information. The actuator is a toothed tone wheel that rotates with the individual wheel. Each tooth on the tone wheel acts as an actuator for the wheel speed sensor. As the tone wheel rotates, the teeth go in and out of the proximity of the sensor.

Section – C

04X06 = 24 Marks

15. Explain Lambda oxygen sensor with construction?

- Ans: **Task-** The lambda probe will adjust the fuel amount that is sent to the engine cylinders by optimizing the air and fuel mixture, which in turn will make the engine work properly. This will also impact the harmful gas emissions rate by making sure the catalytic converter is working correctly.



BHARTIYA SKILL DEVELOPMENT UNIVERSITY

- Location- is a small probe located on the car exhaust, between the exhaust manifold and the catalytic converter.
- Principle- Oxygen sensors work by producing their own voltage when they get hot (approximately 600°F). On the tip of the oxygen sensor that plugs into the exhaust manifold is a zirconium ceramic bulb. The inside and the outside of the bulb is coated with a porous layer of platinum, which serve as the electrodes. The interior of the bulb is vented internally through the sensor body to the outside atmosphere. When the outside of the bulb is exposed to the hot gases of the exhaust, the difference in oxygen levels between the bulb and the outside atmosphere within the sensor causes the voltage to flow through the bulb. If the fuel ratio is lean (not enough fuel in the mixture), the voltage is relatively low — approximately 0.1 volts. If the fuel ratio is rich (too much fuel in the mixture), the voltage is relatively high — approximately 0.9 volts. When the air/fuel mixture is at the stoichiometric ratio (14.7 parts air to 1 part fuel), the oxygen sensor produces 0.45 volts.

16. Explain with construction knock sensor also symptoms of failure ?

- Ans: **LOCATION:-** The knock sensors are located on the top of the crankcase under the intake manifold.
- **TASK:-**The knock sensors detect combustion knocks at excessively high vibrations at the crankcase. Anti-knock control thereby corrects the ignition timing for each individual cylinder when the engine is warm.

Working- The arrangement of this sensor can be done outside of the engine block in the automobile. The main function of this is to record knocking noise within all engine operating conditions to stop engine injure.

The sensor used in the car listens to the sensations which are occurred from the engine block in the car & changes them into electrical voltage signals, which are filtered & estimated inside the control unit.

Failure symptoms-

- An error code can be stored
- Engine power can be reduced
- Fuel consumption can be increased
- Warning light of the engine will be ON
- Slow acceleration

17. Explain types and working of Catalytic converter.

Ans - A catalytic converter uses a chamber called a catalyst to change the harmful compounds from an engine's emissions into safe gases, like steam. It works to split up the unsafe molecules in the gases that a car produces before they get released into the air.

Reduction catalysts: Help reduce nitrogen oxide pollution by removing oxygen. Nitrogen oxides are broken up into nitrogen and oxygen gases, which on their own are harmless.

Oxidation catalysts: Used to change carbon monoxide into carbon dioxide through an opposite process of adding oxygen.

18. Explain Micromechanical pressure sensor with construction, Application and principle?

Ans: **Function-** Micromechanical pressure sensors determine the absolute pressure of liquids and gases by measuring the pressure differential in relation to a reference vacuum.

Principle- diaphragm of the sensor cell is deflected to varying degrees depending on the voltages across them. This leads to a change in the measurement voltage U_M . This as yet unamplified voltage is therefore a measure of the pressure applied to the diaphragm.

Application- Intake-manifold pressure, e.g. for load sensing in engine-management systems.

- Boost pressure for boost-pressure control Ambient pressure for taking into account air density, e.g. in boost-pressure control .
- Oil pressure to take engine load into account in the service display.
- Fuel pressure for monitoring the level of fuel-filter contamination.

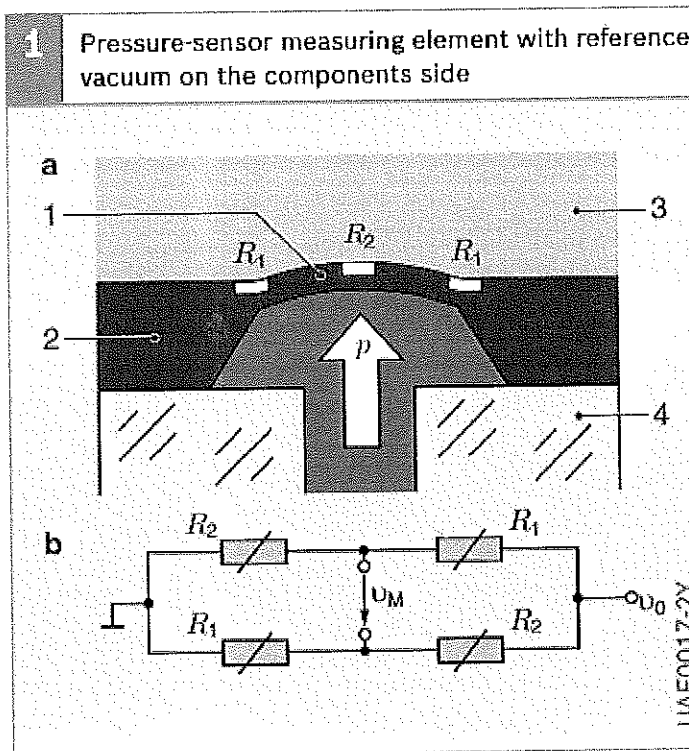

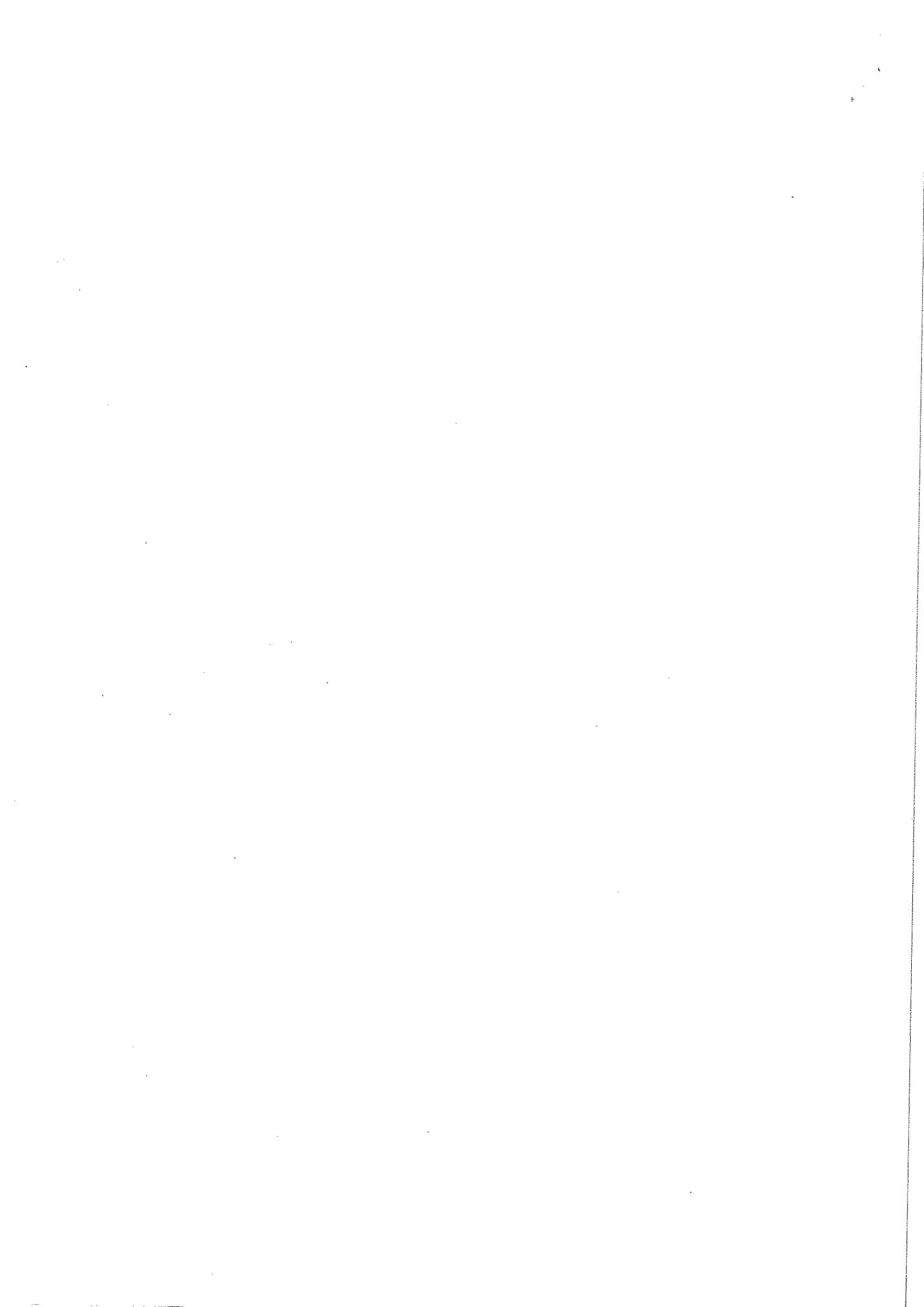

School of Automotive Skills
Session: 2021-22 (Winter Semester)
B. Voc. Program, 5th Semester,
End-Semester Examination

Course Code: AUT1502

Time: 2 Hours

Course Name: Automotive Electrical System

Max. Marks: 50

Instruction: It is mandatory to answer all questions.

Section – A

10X01 = 10 Marks

Q1. Which of the following temperature value is usually not measured in a car?

- a) Fuel temperature.
- b) Manual transmission oil temperature.
- c) Passenger compartment temperature.
- d) Exhaust gas temperature.

Q2. What kind of device is shown in the picture below?

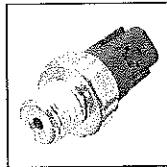

- a) Temperature Sensor.
- b) Vehicle Speed Sensor.
- c) Knock Sensor.
- d) Oil Pressure Switch.

Q3. Which of the following sentences is wrong? Automotive networking is used because....

- a) ...it simplifies the communication between the ECU's.
- b) ...internet of things(IoT) is growing day by day.
- c) ...the amount of ECU's in cars increased rapidly.
- d) ...it reduces the amount of wires.

Q4. Which of the following systems provides the lowest data transfer rate?

- a) CAN-FD.
- b) CAN-B.
- c) CAN-C.
- d) LIN.

Q5. MOST is used to communicate with:

- a) The infotainment systems.
- b) The emission control system.
- c) The powertrain control unit.
- d) Safety systems (e.g. ESP).



BHARTIYA SKILL DEVELOPMENT UNIVERSITY

- Q6. Full form of SMSC in terms of MOST register trademark is.....
- Short Message Service Centre.
 - Standard Microprocessor Chip.
 - Standard Microsystems Corporation.
 - None of the above.
- Q7. Which part of Li-ion cell is act as a barrier for ionic transport?
- Electrode.
 - Electrolyte Reservoir.
 - Seperator.
 - All of the above.
- Q8. The spark ignition system of BMW sparks up to nine times at the end of the compression stroke. What is the purpose?
- To increase the spark accuracy under high RPM.
 - To make the spark system more reliable.
 - To increase the spark duration under low RPM and cold start.
 - To increase the efficiency during coasting.
- Q9. Heat range in a spark plug is a means of designating how a plug will run in operation.
- Hot.
 - Cold.
- Q10. What is the full form of ESA?
- Electrical Spark Actuation.
 - Electronic Spark Advance.
 - Electrical Spark Advance.
 - None of the above.

Section – B

04X04 = 16 Marks

- Q11. Explain the general electrical troubleshooting procedure in an automotive vehicle.
- Q12. Write down the most important specifications you will find on car battery.
- Q13. What do you understand by Automotive Ethernet?
- Q14. Most of the modern cars use headlamps like the one shown below. There are two different type of reflectors A and B. Which reflector type would you choose for high beam and for low beam, justify your answer.

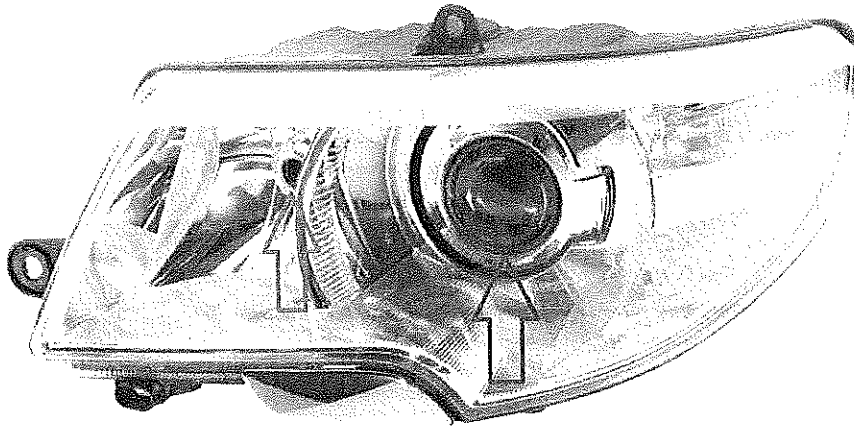

A

B

Section – C

04X06 = 24 Marks

- Q15. Explain Vehicle's Electrical Starting System equipped with the ESB (Emergency Starting Battery) with an appropriate circuit diagram.
- Q16. What are most common starter solenoid problems and bad symptoms in an automotive vehicle?
- Q17. Suppose an old technician comes to you and argues; "Automotive networking systems are not required! Back in the good old days the cars worked totally fine without these systems!" Explain him with four different reasons why these systems are crucial today.
- Q18. Explain the Gas Discharge lighting technology used in cars. Compare Filament (Halogen Bulbs) and Light Arc Gas Discharge Lamp (Xenon).

Signature

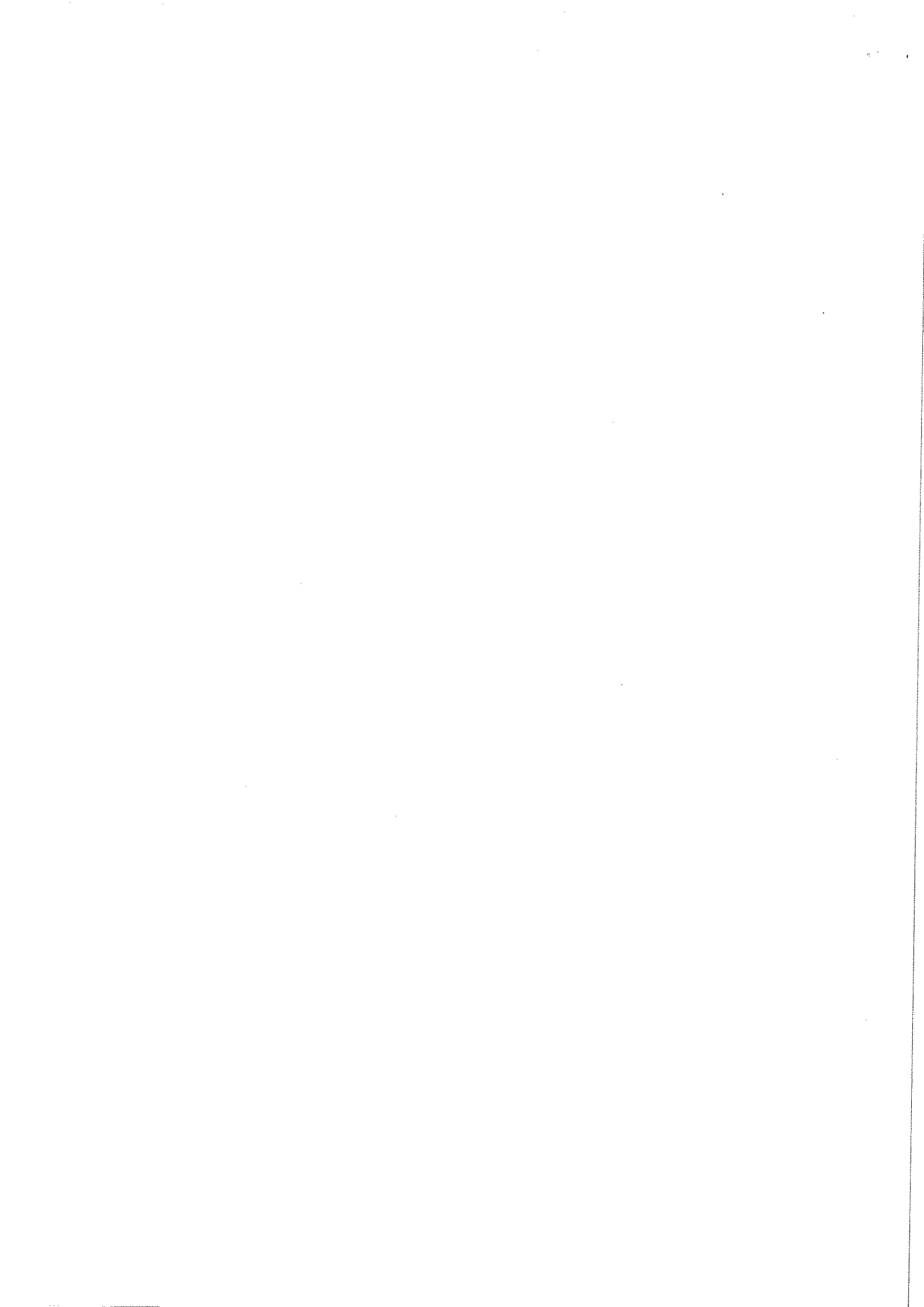

School of Automotive Skills
Session: 2021-22 (Winter Semester)
B. Voc. Program, 5th Semester,
End Semester Examination

Course Code: AUT1502
Course Name: Automotive Electrical System

Time: 2 Hours
Max. Marks: 50

Section – A

10X01 = 10 Marks

Q1. Which of the following temperature value is usually not measured in a car?

Answer: a) Fuel Temperature.

Q2. What kind of device is shown in the picture below?

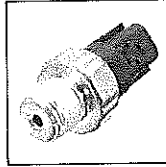

Answer: d) Oil Pressure Switch.

Q3. Which of the following sentences is wrong? Automotive networking is used because....

Answer: b) ...internet of things (IoT) is growing day by day.

Q4. Which of the following systems provides the lowest data transfer rate?

Answer: d) LIN.

Q5. MOST is used to communicate with:

Answer: a) The Infotainment System.

Q6. Full form of SMSC in terms of MOST register trademark is.....

Answer: c) Standard Microsystems Corporation.

Q7. Which part of Li-ion cell is act as a barrier for ionic transport?

Answer: c) Seperator.

Q8. The spark ignition system of BMW sparks up to nine times at the end of the compression stroke.

What is the purpose?

Answer: c) To increase the spark duration under low RPM and cold start.

Q9. Heat range in a spark plug is a means of designating how a plug will run in operation.

Answer: a) Hot.

Q10. What is the full form of ESA?

Answer: b) Electronic Spark Advance.



Section – B

04X04 = 16 Marks

Q11. Explain the general electrical troubleshooting procedure in an automotive vehicle.

Answer:

With time, every mechanic will gradually develop its own troubleshooting procedure. Until then, using a general troubleshooting procedure will help you get there and learn what works best for you at the same time.

The most important steps are:

1. Confirming the problem

Customers don't always provide an accurate and detailed description of the problem at hand. If a driver notices a problem in the lighting system of his vehicle, he will usually indicate that "a light bulb doesn't work". This kind of description really does not say much about the nature of the problem. It is therefore essential to check the whole lighting system to find out which lighting device is not working before everything else.

2. Intermittent electrical problems

It's also important to investigate to see if the problem is present at all time or intermittent. Finding the source of an electrical problem is hard enough without having to perform tests on a circuit while everything is in good working condition. Sadly, in the case of an intermittent problem, there's not much to be done. It's almost impossible to locate a faulty component when the problem is not present.

3. Developing a hypothesis

Write down a list of the most likely culprits and keep it within reach. Your hypothesis doesn't have to be 100% right all the time and you shouldn't feel tied down by it. Its purpose is only to give you a starting point for the troubleshooting process. As you gain experience, you'll learn to pose better hypotheses which should allow you to skip some steps and jump right down to where the problem is most likely located right away.

4. Collecting technical information

Before starting any kind of troubleshooting on an electrical system, get your hands on your car's **repair manual** and find out the wiring diagram corresponding to the system concerned. Having access to electrical diagrams to perform your test is a definite advantage and is not to neglect.

5. Performing the preliminary steps

If the electrical problem is permanent and related to a particular circuit, start by performing a visual inspection of the circuit in question. The cause of an electrical problem is sometimes obvious and performing a visual inspection could save you some precious time.

The main elements to visually inspect, depending on the electrical circuit involved, are:

- Loose battery terminals;
- Main electrical connectors;
- Control modules ground;
- Engine, transmission and body grounds.

If the problem is intermittent, check the electrical sub-circuits of the circuit in question for:

- Partially disconnected connector;
- Deformed or damaged connector plugs
- Bad electrical splice;
- Electrical circuit too close to a magnetic field;



- Antifreeze or brake fluid on the connections.
- Testing the battery

6. Troubleshooting

Inspect the main components of the system

9 out of 10 times your troubleshooting will stop right there. The cause of an electrical problem is most frequently the main component of the system.

For example, if the LR (Left-Front) blinking light stops working, the light bulb is most likely burnt. If the RF window stops going up or down, there's almost 90% chance that the RF power window regulator is at fault. If it's not, the culprit is most likely the second most important component, namely the power window main switch.

- **Testing the fuses**

If there's no power coming to the motor, the next step is to check the fuses. Electrical systems are divided into sectors, and each sector has a fuse protecting it against overloads.

The fuse consists of a lead wire placed on a support and integrated into the input circuit of the sector. Lead is a metal that heats up easily when the current passes through and quickly melts and cuts off the current in the sector instantly in case of overload.

A blown fuse is often a consequence of an electrical problem and rarely the cause of it. Make certain that you find what caused the fuse to blow in the first place before replacing it or it will simply blow again.

- **Visually**

Locate the fuse protecting the electrical circuit on your car wiring diagram. A number or code next to it should indicate where it's found on the vehicle.

Use the fuse removal tool provided with the fuse box to easily remove the fuse and inspect it. If you notice a black spot or if the lead wire looks like its cut in half, the fuse is definitely blown and needs to be changed.

- **Using a multimeter**

To test a fuse using a multimeter, select the continuity test or resistance mode. Try to touch both positive and negative probes together and note down the value displayed on the multimeter. Different multimeter will display different codes or sounds to indicate continuity or an Open Loop condition.

Place the probes of the multimeter on the two metal blades at the back of the fuse. If a beep is heard or some resistance reading is displayed, the fuse is still good. On the other hand, if it doesn't beep or "OL" appears on the multimeter, the fuse is defective and will need to be replaced.

- **Using a test light**

A test light is the best tool to use for fuse testing. In fact, a test light typically can't tell you anything else than if there's power or not. No voltage reading is available but when the time comes to test a fuse, that's all we need.

With the ignition key turned on, connect the test light clip to the negative terminal of the battery and alternatively touch the fuse's metal blades with the probe. If the fuse is blown, the test light will light up only when touching one of the two metal blades.

7. Isolating the problem

The key here is to eliminate a good part of the circuits and to concentrate the research on the sub circuit which could be at the source of the problem. Since the problem is not the motor, nor the power source,



the faulty component can only be located in two places: between the motor and the power source or between the motor and the ground.

Depending on the results of the test you've performed so far, you are now looking to find why either the power or ground is not being measured at the connector. If there's no 12v to the connector, inspect the circuit ahead of the motor. Start with the power distribution center or just after the fuse. Follow the wire and test it at every connector along the way until you find one with no power.

Same thing for the ground but in the opposite direction. Inspect the system wiring diagram and find the location of the ground for this motor. Remove the trims, follow the ground wire and inspect it for damages as you go.

8. Performing the repair

This one is pretty self-explanatory. Once you have found the cause of the electrical problem, you can then formulate a diagnostic with confidence in mind and repair the whole thing.

In the case of a burnt component, make sure you clearly understand what caused it to burn in the first place before you replace it. Failure to do so could result in the component blowing up again the moment you plug it back in. If there's a short on the wire or a skinned ground wire is touching another 12v power source, the current could instantly ruin expensive internal electronic elements. Only reinstall the new part once you have repaired the problem.

9. Performing post-repair verifications

Never forget to confirm the repair before putting the car back on the road. Nothing is more frustrating than dedicating hours into troubleshooting a faulty radiator fan, taking the car out for a drive right after you have replaced the fan relay only to find yourself stranded on the side of the road with an overheating engine minutes later and in need of a tow truck.

10. Wrapping it up

Electrical problems can sometimes be intimidating and somewhat daunting at first. Rest assured, with the help of your **vehicle's repair manual** and some basic electrical troubleshooting knowledge, everybody should be able to find and fix most electrical problems in no time.

Q12. Write down the most important specifications you will find on car battery.

Answer:

Car battery specs conform to standards developed by the Battery Council International (BCI) and the SAE. Many of the specs appear on the common battery label or sticker as well as in battery manufacturers' published literature. For car guys, the most important specs are:

1. **Cold Cranking Amps (CCA):** The discharge load in amperes that a new, fully charged battery can deliver at 0 degrees F for 30 seconds while maintaining a voltage of 1.20 volts/cell or higher.
2. **Cranking Amps (CA):** The discharge load in amperes that a new, fully charged battery at 32 degrees F can continuously deliver for 30 seconds while maintaining a terminal voltage equal to or higher than 1.20 volts/cell. CA ratings can be misleading because they can be up to 30 percent higher than the equivalent CCA rating. The BCI requires that a battery carrying a statement of its CA performance must also list its CCA capacity.
3. **Reserve Capacity (RC):** If listed, this is the number of minutes a new, fully charged battery at 80 degrees F can be discharged at 25 amperes while maintaining a voltage of 1.75 volts/cell or higher. For a 12-volt battery (six cells), RC is the number of minutes it can maintain a voltage

of 10.5 volts with a 25-amp draw; therefore, a "75-minute" battery lasts 75 minutes under these conditions. The bigger the RC, the better; modern cars with lots of accessories can see a current discharge rate much greater than 25 amps.

4. **Deep Cycle:** This relates to the torture test that (assuming it passes) lets a battery truly call itself "deep cycle." An SAE-specified measurement of the battery's ability to withstand repeated discharge/recharge cycles, it lasts over 100 hours.
5. **Date Code:** Most batteries have a date code, usually a long string of numbers and letters that show when the battery was purchased. One row of one- or two-letter codes indicates the month, the other row of numbers is the last digit of the year. The relevant date code in the ID should have been stamped or highlighted at the time of purchase.
6. **Group Size:** This is the standard "envelope size" of the battery case that equates to its height, width, length, and terminal position, as established by BCI. Batteries with the same group number physically interchange. In many instances the group size forms at least part of the battery manufacturer's part number.

Q13. What do you understand by Automotive Ethernet?

Answer:

The Ethernet used in automotive vehicles such as cars is known as **Automotive Ethernet**. It is a physical network which is used to connect various components within a car using wired network. This Ethernet type has following features:

- Should support High Data Rate without EMI/EMC problem.
- Should meet latency, synchronization and bandwidth requirements.
- Power should be delivered over Ethernet cables.
- Should support distributed network architecture for communication.
- Should work with TCP/IP based protocols.

Q14. Most of the modern cars use headlamps like the one shown below. There are two different type of reflectors A and B. Which reflector type would you choose for high beam and for low beam, justify your answer.

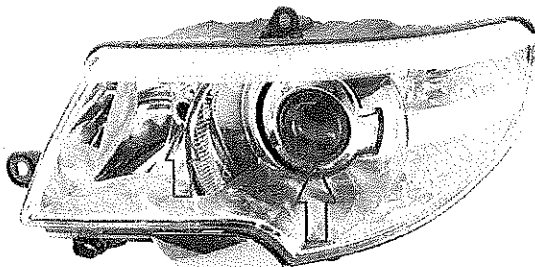

A B

Answer:

Type A reflector will be preferable for high beam because, it is a halogen type lamp which is more suitable for traffic conditions on highways, so as the fellow drivers with various automotive cannot lose their sight from the road.

Type B reflector will be preferable for low beam because, it is a Xenon type projector lamp which is more preferable for low sighting while driving a car as it covers wide area for driver's comfort to drive.

Section – C

06X04 = 24 Marks

Q15. Explain Vehicle's Electrical Starting System equipped with the ESB (Emergency Starting Battery) with an appropriate circuit diagram.

Answer:

ESB, Emergency Starting Battery VS (Vehicle Series)

ESB, means "Emergency Starting Battery." A new manufacturing innovation in the battery field. A very promising proposal which will offer more safety and reliability to the automotive world.

An innovation which will insure you reach your destination safely. ESB can be used mainly as an alternative (saving) back-up emergency starting battery, which is installed and directly connected to the vehicle's electrical power system. It is a battery that will get you out of a difficult situation and will start your engine when the main battery will just not do it.

The ESB further improves the passenger's safety regarding all possible consequences that might be followed after a power failure from the vehicle's main battery. It provides an interruptible (or manual) power back-up support for the purpose of engine starting and certainly for all other electrical consumption loads.

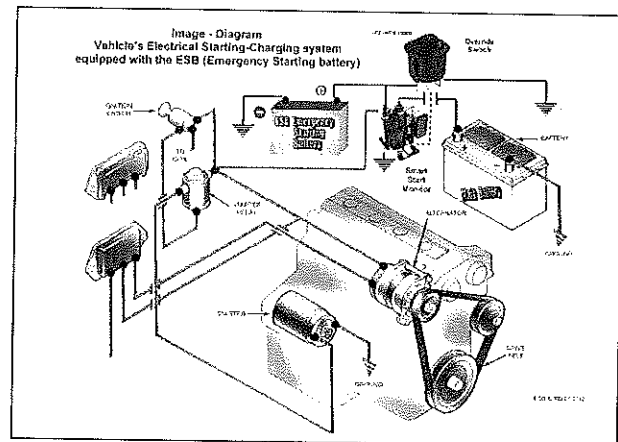

What does it mean to be equipped with an ESB battery?

- You will never have to worry again that you might not get to your destination due to a dead battery.
- You will never be in danger of waiting for help, on the road, or out in the middle of nowhere. You will safely reach your destination.

ESB is a very handy 12V rechargeable sealed - without maintenance battery with long life time (5-10 years) and with a quite low manufacturing cost. It is very small in size and lightweight. It weighs 6.60 pounds approximately and offers a very high rate starting current, from 200Amps to 800Amps.

Due to the very low self-discharge rate, even if the vehicle is parked for 4 months the ESB will always be ready to start your engine.

It uses safe technologies, total recyclable materials and it can be mounted in any orientation. It is US DOT and IATA certified as non-spillable battery.

The ESB battery could be manufactured in two different battery technologies.

- A. In VRLA (PbCaSn) technology (with the weight of 6.60 pounds).
- B. In LiFePo4 nanotechnology based innovation (with the weight of 3.30 pounds).

It is quite easy to be installed. It could be activated manually, or be in a fully automatic mode by using optional a smart start monitors for an interruptible battery power operation. "You will never need to get out of your vehicle; you just carry on and drive."



ESB is charged separately in the same way as the main vehicle's battery. Installation could be placed at the vehicle's manufacturing plant, as from the authorized technical partners too.

Conclusion

ESB is ready to be applied in the automotive industry and perhaps in the future it might be a new standard to the international motor vehicle market. A low cost, highly efficient product that offers much further increased transportation's safety and reliability. A proposal that will definitely improve our automotive life.

Q16. What are most common starter solenoid problems and bad symptoms in an automotive vehicle?

Answer:

Suggestion 01: Bad Wiring

Poor and hurried wiring lead to either inadequate current supply to the starter solenoid or a more dangerous problem of shorting. Both can make a starter solenoid to malfunction and cause starter system problems. Bad wiring instances include terminals that are left loose or connected the wrong way.

Suggestion 02: Excessive Heating

It happens when extremely high currents flow to or through the solenoid, and for too long. It can be caused by instances where the ignition switch is left in the 'start' position for long. The soldering in the contacts melts, and they weld together. When that happens, the starter solenoid becomes damaged because you can no longer control its switching function.

Suggestion 03: Excessive Moisture

If moisture is left to get inside the starter solenoid, it leads to corrosion of the electrical contacts. The result is reduced conductivity of the contact surfaces. The efficiency the starter solenoid becomes greatly reduced, and you experience occasional starter fails. You may hear the starter click and then stop almost immediately when the current proves too low for the whole operation to finish.

Suggestion 04: Too Much Tightening of Bolts and Other Fasteners

It's usually very easy to over tighten bolts without being aware of it. It happens especially if you're using tightening tools with a high torque, which causes some parts inside and outside of the starter solenoid to break or bend. It can lead to shorting or mechanical failure of the affected parts. The starter solenoid is just one of the components of a starter system. While a problem with starting the engine may be as a result of it being damaged, it's not always the case, and learning how to diagnose a faulty one is important. So, how do you tell that it's your car's starter solenoid that's bad? Here are indicators to help you in ascertaining that.



Symptoms of a Bad Starter Solenoid

1. A series of rapid or successive clicks coming from the starter solenoid.
2. The starter continues to rotate even after the drive gear disengages and start button has been released from the 'on' position.
3. The starter solenoid makes a clicking sound and moves a little, but the starter does not rotate.
4. The starter continues to rotate after the start button has been released, but the drive-gear doesn't reverse.

Q17. Suppose an old technician comes to you and argues; "Automotive networking systems are not required! Back in the good old days the cars worked totally fine without these systems!" Explain him with four different reasons why these systems are crucial today.

Answer:

1. A decreased number of dedicated wires is required for each function, and thus reduces the size of the wiring harness. System cost, weight, reliability, serviceability, and installation are improved.
2. Common sensor data, such as vehicle speed, engine temperature, etc. are available on the network, so data can be shared, thus eliminating the need for redundant sensors.
3. Networking allows greater vehicle content flexibility because functions can be added through software changes. Existing systems require an additional module or additional I/O pins for each function added.
4. Car manufacturers are discovering new features that are enabled by networking. For example, the 1996 Lincoln Continental's Memory Profile System stores each driver's preference for ride firmness, seat positions, steering assist effort, mirror positions, and even radio station presents.

Q18. Explain the Gas Discharge lighting technology used in cars. Compare Filament (Halogen Bulbs) and Light Arc Gas Discharge Lamp (Xenon).

Answer:

Gas discharge lamps generate light according to the physical principle of electrical discharge. Through the application of an ignition voltage from the ballast (up to 23 KV in 3rd generation HELLA ballasts), the gas between the lamp electrodes (filled with the inert gas xenon and a mixture of metals and metal halides) is ionized and made to glow with the aid of a light arc.

During the controlled feeding of alternating current (at approx. 400 Hz) the liquid and solid substances evaporate due to the high temperatures. The lamp only achieves its full brightness after a few seconds when all the components have been ionized.

To prevent destruction of the lamp through uncontrolled increases in current, the current is limited by a ballast. Once the full light output has been reached, an operating voltage (not the ignition voltage) of only 85 V is necessary to keep up the physical process. Luminous flux, luminous efficiency, luminance, and service life are significantly better than with halogen bulbs.

Gas discharge lamps are categorized according to their respective development version: D1, D2, D3, and D4. The "D" stands for "discharge". There are some major differences between the generations.

The D1 lamps, for instance – the original xenon bulbs – have an integrated ignition section. D2 lamps, on the other hand, only consist of the socketed burner itself and, unlike all other development versions of automotive gas discharge lamps, have no exterior protective glass bulb around the discharge tube. All further developments have a UV protection bulb and are much more robust in their design.

The old D1 is often mistaken for the current D1 S/R lamp with integrated ignition module. Further developments of the D1 and D2 lamps, the D3 and D4 lamps, are more environmentally compatible, as they use no mercury. Due to different electrical parameters (42 V instead of 85 V arc voltage, with identical output), the D3 and D4 lamps cannot be used with the control units for D1 or D2 lamps.

Basis	Halogen Bulb (H7)	Gas Discharge Lamp
Light Source	Filament	Light Arc
Luminance	1450 cd/m ²	3000 cd/m ²
Power	55W	35W
Energy Balance	8% light radiation & 92% heat radiation.	28% light radiation, 58% heat radiation & 14% UV radiation.
Service Life	Approx. 500 hrs.	Approx. 2500 hrs.
Vibration-proof	To a certain extent	Yes
Electronic Control	No	Yes
Ignition Voltage	No	Yes 23,000 V (3 rd Gen.)

School of Automotive Skills
Session: 2021-22 (Winter Semester)
B. Voc. Program, 5th Semester,
End-Semester Examination

Course Code: AUT1502

Course Name: Automotive Electrical System

Instruction: It is mandatory to answer all questions.

Time: 2 Hours

Max. Marks: 50

Section – A

10X01 = 10 Marks

Q1. Factors that positively influence a vehicle interior light source:

- a) Excessive on-board voltage.
- b) Switching-on process.
- c) Filling pressure & gas.
- d) High temperatures.

Q2. What kind of device is shown in the picture below?



- a) Temperature Sensor.
- b) Vehicle Speed Sensor.
- c) Knock Sensor.
- d) Oil Pressure Switch.

Q3. What are the causes for a defective supply voltage?

- a) Broken Wire.
- b) Corroded plug.
- c) Defective main fuse.
- d) All of the above.

Q4. Which of the following systems provides the fastest data transfer rate?

- a) CAN-FD.
- b) CAN-B.
- c) CAN-C.
- d) LIN.

Q5. MOST is used to communicate with:

- a) The infotainment systems.
- b) The emission control system.
- c) The powertrain control unit.
- d) Safety systems (e.g. ESP).



BHARTIYA SKILL DEVELOPMENT UNIVERSITY

Q6. Full form of SMSC in terms of MOST register trademark is.....

- a) Short Message Service Centre.
- b) Standard Microprocessor Chip.
- c) Standard Microsystems Corporation.
- d) None of the above.

Q7. Which part of Li-ion cell is act as a barrier for ionic transport?

- a) Electrode.
- b) Electrolyte Reservoir.
- c) Seperator.
- d) All of the above.

Q8. What is the main function of relay?

- a) Sends and receive radio signals.
- b) Switches electrical currents.
- c) Generate high voltage.
- d) Generates electricity.

Q9. Heat range in a spark plug is a means of designating how a plug will run in operation.

- a) Hot.
- b) Cold.

Q10. What is the full form of ESA?

- a) Electrical Spark Actuation.
- b) Electronic Spark Advance.
- c) Electrical Spark Advance.
- d) None of the above.

Section – B

04X04 = 16 Marks

Q11. Define the optimum system approach for the system when any kind of electrical faults occur.

Q12. An electric motor has a small internal resistance. How does this affect current consumption and power?

Q13. Explain smart charging process for an electric vehicle.

Q14. The voltage of the rear window wiper plug is to be measured. Name the circuit elements and correctly draw in the measuring wires. (In circuit diagrams, available switches are typically drawn in their normal position)

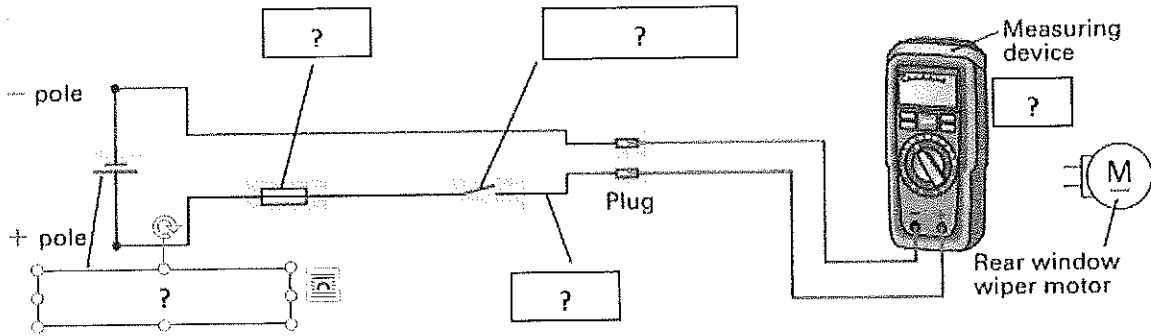

Section – C

04X06 = 24 Marks

Q15. Explain the followings:

1. OBD-II Scanning Tool.
2. Automotive Ethernet.
3. MOST (Media Oriented System Transport).

Q16. Write down the most important specifications you will find on car battery.

Q17. Explain the Gas Discharge lighting technology used in cars. Compare Filament (Halogen Bulbs) and Light Arc Gas Discharge Lamp (Xenon).

Q18. A manufacturer specifies the maximum resistance for the following leads. Calculate the voltage drop for each wire at maximum resistance.

Main starter lead	$I = 450 \text{ A}$	$R_{\text{max}} = 0.001 \text{ Ohm}$
Supply wire for headlights	$I = 10 \text{ A}$	$R_{\text{max}} = 0.03 \text{ Ohm}$
Sensor signal wire	$I = 0.01 \text{ A}$	$R_{\text{max}} = 0.5 \text{ Ohm}$

Signature

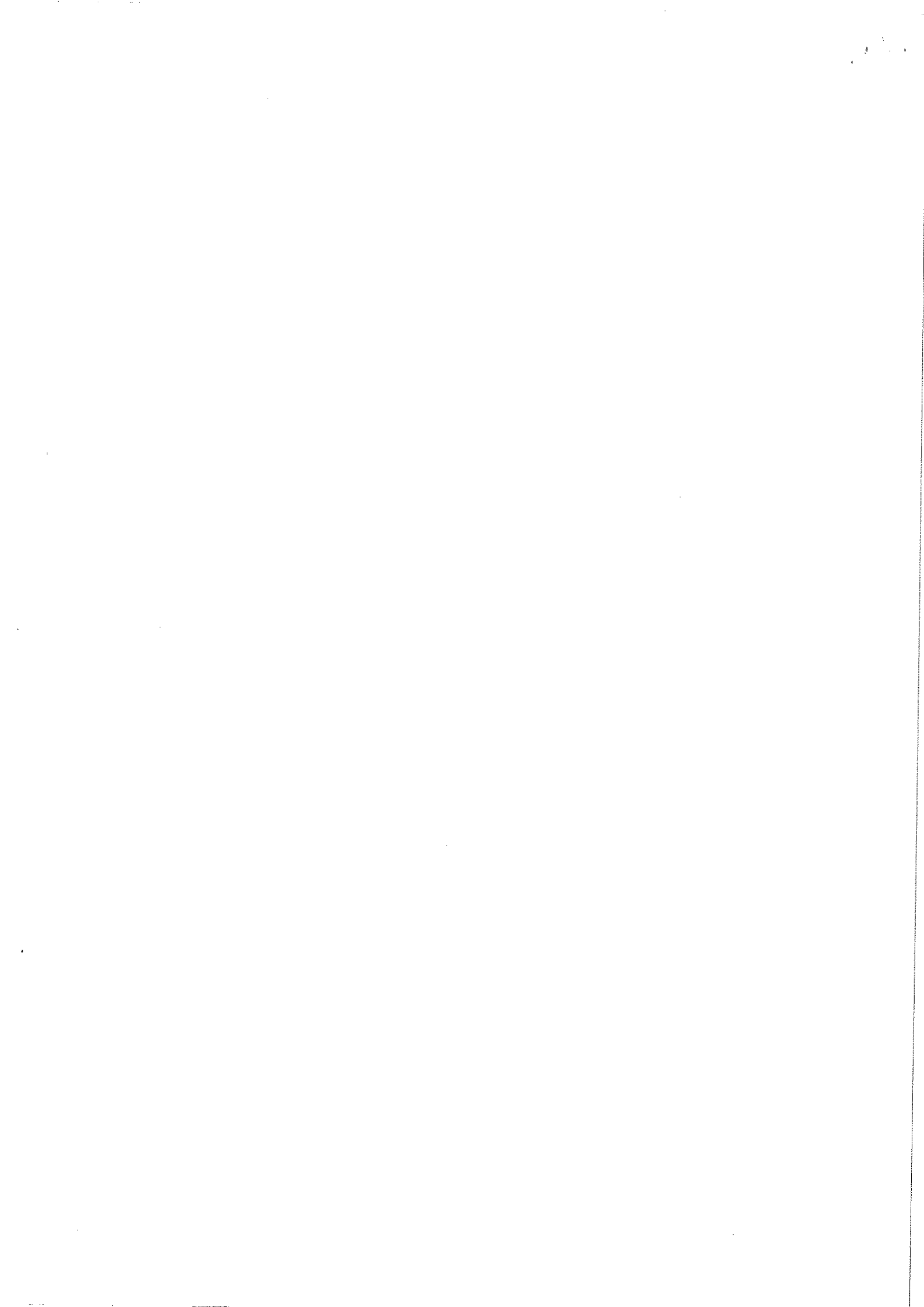



School of Automotive Skills
Session: 2021-22 (Winter Semester)
B. Voc. Program, 5th Semester,
End Semester Examination

Course Code: AUT1502

Time: 2 Hours

Course Name: Automotive Electrical System

Max. Marks: 50

Section – A

10X01 = 10 Marks

Q1. Factors that positively influence a vehicle interior light source:

Answer: c) Filling pressure & gas.

Q2. What kind of device is shown in the picture below?

Answer: b) Vehicle Speed Sensor.

Q3. What are the causes for a defective supply voltage?

Answer: d) All of the above.

Q4. Which of the following systems provides the faster data transfer rate?

Answer: a) CAN-FD.

Q5. MOST is used to communicate with:

Answer: a) The Infotainment System.

Q6. Full form of SMSC in terms of MOST register trademark is.....

Answer: c) Standard Microsystems Corporation.

Q7. Which part of Li-ion cell is act as a barrier for ionic transport?

Answer: c) Separator.

Q8. What is the main function of relay?

Answer: b) Switches Electrical Currents.

Q9. Heat range in a spark plug is a means of designating how a plug will run in operation.

Answer: a) Hot.

Q10. What is the full form of ESA?

Answer: b) Electronic Spark Advance.

Section – B

04X04 = 16 Marks

Q11. Define the optimum system approach for the system when any kind of electrical faults occur.

Answer:

Step 01:

What — Vehicle model, Engine, Year, Transmission and related Systems

When — Date, Time of the Day, Weather Conditions, Frequency



Where — Road Conditions, Altitude and Traffic Situation

How — System Symptoms, Operating Conditions, Service History and Aftermarket Accessories installed on the vehicle

Step 2:

Operate the system and perform a road test if necessary. Verify all the parameters of the incident and ask the customer to come with you while you perform the road test. You can even ask the client to drive the vehicle so you can sit on the passenger side and monitor what is happening and make sure the problem is not related to incorrect operation of the vehicle.

If the customer's complaint can't be repeated, jump to "Incident Simulation Tests" section below.

Step 3:

Get the materials and equipment required to perform the troubleshooting including a power supply and the system operation descriptions contained in your vehicle's repair manual. If you have access to a TSB software, make sure to look if there's already a technical service bulletin for the same symptoms and problem.

Step 4:

Visually inspect the system and look out for damaged wires and possible faulty components. Find which circuit may be faulty and which components could cause those symptoms.

Step 5:

If a damaged wire is found, repair the wiring. If not, replace the faulty component.

Step 6:

Confirm the repair and make sure no other problems are lurking in the shadows, especially if the problem was a damaged wire. When a wire is damaged because it's rubbing against a sharp metal bracket or part, it's not uncommon to find other damaged wires in the same harness. Perform another road test and make sure everything is fine before delivering the car back to the client.

Q12. An electric motor has a small internal resistance. How does this affect current consumption and power?

Answer:

Power transfer between a voltage source and an external load is at its most efficient when the resistance of the load matches the internal resistance of the voltage source. If the load resistance is too low, then most of the power output of the voltage source is dissipated as heat inside the source itself.

Q13. Explain smart charging process for an electric vehicle.

Answer:

Smart charging means adapting the charging cycle of EVs to both the conditions of the power system and the needs of vehicle users. This facilitates the integration of EVs while meeting mobility needs. Smart charging for electric vehicles (EVs) holds the key to unleash synergies between clean transport sector and low-carbon electricity. It minimizes the load impact from EVs and unlocks the flexibility to use more solar and wind power.

- Benefits:

- Reduce grid infrastructure investments.
- Network congestion management.
- Peak shaving.

Provision of ancillary service.

Q14. The voltage of the rear window wiper plug is to be measured. Name the circuit elements and correctly draw in the measuring wires. (In circuit diagrams, available switches are typically drawn in their normal position)

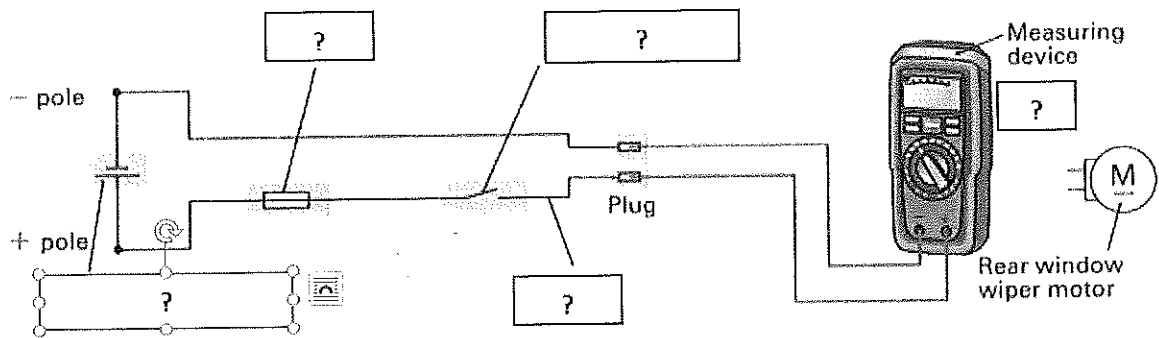

Answer:

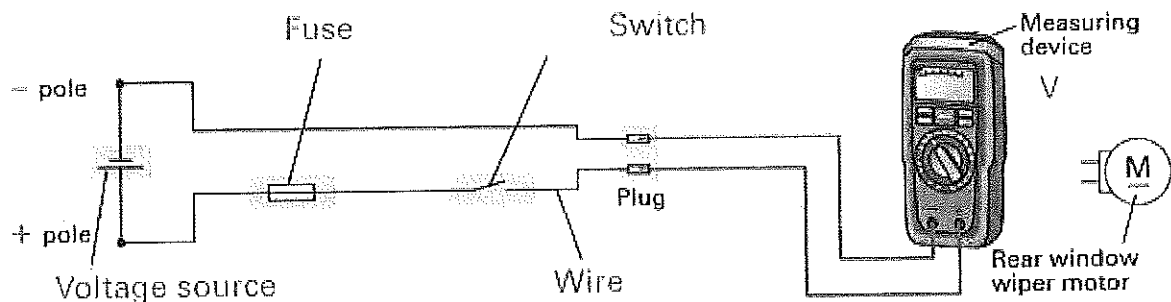

Section – C

06X04 = 24 Marks

Q15. Explain the followings:

1. OBD-II Scanning Tool.
2. Automotive Ethernet.
3. MOST (Media Oriented System Transport).

Answer:

1. OBD-II Scanning Tool

Scan tools are frequently of great help when it comes to diagnosing more complex electrical problems. The live data feature can let you know if an electrical actuator is supposed to be engaged when it's not and if input is coming into a specific module in a glimpse. The possibility to activate specific circuits and perform special tests is also a must.

As a general rule, one could say that the best OBD2 scan tools with the most interesting features are usually the most expensive ones too. Luckily, because of the recent development in technology, you can now find a pretty good OBD2 scan tool even on a low budget.

2. Automotive Ethernet:

The Ethernet used in automotive vehicles such as cars is known as **automotive Ethernet**. It is a physical network which is used to connect various components within a car using wired network. This Ethernet type has following features: should support High Data Rate without EMI/EMC problems. Should meet latency, synchronization and bandwidth requirements. Power should be delivered over Ethernet cables. Should support distributed network architecture for communication. Should work with TCP/IP based protocols.

3. MOST:

MOST (Media Oriented Systems Transport) is a **high-speed multimedia network technology optimized by the automotive industry**. It can be used for applications inside or outside the car. The serial MOST bus uses a daisy-chain topology or ring topology and synchronous data communication to transport audio, video, voice and data signals via plastic optical fiber (POF) (MOST25, MOST150) or electrical conductor (MOST50, MOST150) physical layers. MOST technology is used in almost every car brand worldwide, including Audi, BMW, General Motors, Honda, Hyundai, Jaguar, Lancia, Land Rover, Mercedes-Benz, Porsche, Toyota, Volkswagen, SAAB, SKODA, SEAT and Volvo. SMSC and MOST are registered trademarks of Standard Microsystems Corporation ("SMSC"), now owned by Microchip Technology.

Q16. Write down the most important specifications you will find on car battery.

Answer:

Car battery specs conform to standards developed by the Battery Council International (BCI) and the SAE. Many of the specs appear on the common battery label or sticker as well as in battery manufacturers' published literature. For car guys, the most important specs are:

1. **Cold Cranking Amps (CCA):** The discharge load in amperes that a new, fully charged battery can deliver at 0 degrees F for 30 seconds while maintaining a voltage of 1.20 volts/cell or higher.
2. **Cranking Amps (CA):** The discharge load in amperes that a new, fully charged battery at 32 degrees F can continuously deliver for 30 seconds while maintaining a terminal voltage equal to or higher than 1.20 volts/cell. CA ratings can be misleading because they can be up to 30 percent higher than the equivalent CCA rating. The BCI requires that a battery carrying a statement of its CA performance must also list its CCA capacity.
3. **Reserve Capacity (RC):** If listed, this is the number of minutes a new, fully charged battery at 80 degrees F can be discharged at 25 amperes while maintaining a voltage of 1.75 volts/cell or higher. For a 12-volt battery (six cells), RC is the number of minutes it can maintain a voltage of 10.5 volts with a 25-amp draw; therefore, a "75-minute" battery lasts 75 minutes under these conditions. The bigger the RC, the better; modern cars with lots of accessories can see a current discharge rate much greater than 25 amps.
4. **Deep Cycle:** This relates to the torture test that (assuming it passes) lets a battery truly call itself "deep cycle." An SAE-specified measurement of the battery's ability to withstand repeated discharge/recharge cycles, it lasts over 100 hours.

5. **Date Code:** Most batteries have a date code, usually a long string of numbers and letters that show when the battery was purchased. One row of one- or two-letter codes indicates the month, the other row of numbers is the last digit of the year. The relevant date code in the ID should have been stamped or highlighted at the time of purchase.
6. **Group Size:** This is the standard "envelope size" of the battery case that equates to its height, width, length, and terminal position, as established by BCI. Batteries with the same group number physically interchange. In many instances the group size forms at least part of the battery manufacturer's part number.

Q17. Explain the Gas Discharge lighting technology used in cars. Compare Filament (Halogen Bulbs) and Light Arc Gas Discharge Lamp (Xenon).

Answer:

Gas discharge lamps generate light according to the physical principle of electrical discharge. Through the application of an ignition voltage from the ballast (up to 23 KV in 3rd generation HELLA ballasts), the gas between the lamp electrodes (filled with the inert gas xenon and a mixture of metals and metal halides) is ionized and made to glow with the aid of a light arc.

During the controlled feeding of alternating current (at approx. 400 Hz) the liquid and solid substances evaporate due to the high temperatures. The lamp only achieves its full brightness after a few seconds when all the components have been ionized.

To prevent destruction of the lamp through uncontrolled increases in current, the current is limited by a ballast. Once the full light output has been reached, an operating voltage (not the ignition voltage) of only 85 V is necessary to keep up the physical process. Luminous flux, luminous efficiency, luminance, and service life are significantly better than with halogen bulbs.

Gas discharge lamps are categorized according to their respective development version: D1, D2, D3, and D4. The "D" stands for "discharge". There are some major differences between the generations. The D1 lamps, for instance – the original xenon bulbs – have an integrated ignition section. D2 lamps, on the other hand, only consist of the socketed burner itself and, unlike all other development versions of automotive gas discharge lamps, have no exterior protective glass bulb around the discharge tube. All further developments have a UV protection bulb and are much more robust in their design.

The old D1 is often mistaken for the current D1 S/R lamp with integrated ignition module. Further developments of the D1 and D2 lamps, the D3 and D4 lamps, are more environmentally compatible, as they use no mercury. Due to different electrical parameters (42 V instead of 85 V arc voltage, with identical output), the D3 and D4 lamps cannot be used with the control units for D1 or D2 lamps.



Basis	Halogen Bulb (H7)	Gas Discharge Lamp
Light Source	Filament	Light Arc
Luminance	1450 cd/m ²	3000 cd/m ²
Power	55W	35W
Energy Balance	8% light radiation & 92% heat radiation.	28% light radiation, 58% heat radiation & 14% UV radiation.
Service Life	Approx. 500 hrs.	Approx. 2500 hrs.
Vibration-proof	To a certain extent	Yes
Electronic Control	No	Yes
Ignition Voltage	No	Yes 23,000 V (3 rd Gen.)

Q18. A manufacturer specifies the maximum resistance for the following leads. Calculate the voltage drop for each wire at maximum resistance.

Main starter lead	I = 450 A	R max = 0.001 Ohm
Supply wire for headlights	I = 10 A	R max = 0.03 Ohm
Sensor signal wire	I = 0.01 A	R max = 0.5 Ohm

Answer:

Given: R₁ = 0.001 Ohm, R₂ = 0.03 Ohm, R₃ = 0.5 Ohm

I₁ = 450 A, I₂ = 10 A, I₃ = 0.01 A.

Solution: V = I.R;

V₁ = 0.45 V;

V₂ = 0.3 V;

V₃ = 0.005 V.



Q.P. Set A

School of Automotive Skills
Session: 2021-22 (Winter Semester)
B. Voc. Program, 5th Semester,
End-Sem. Examination

Course Code: AUT1503

Time: 2 Hour

Course Name: Workshop Management

Max. Marks: 50

Instruction:

1. Answer all questions from section – A, each question carries one mark.
2. Attempt all questions from section – B, each question carries four marks.
3. Answer all questions from section – C, each question carries six marks.

Section – A

01X10 = 10 Marks

Q1. What does A in CLRA stands for?

- a) Abolition
- b) Asylum
- c) Abort
- d) None of the above

Q2. Which of the following forecasting methods takes a fraction of forecast error into account for the next period forecast?

- a) Simple moving average method
- b) Moving average method
- c) Weighted moving average method
- d) Exponential smoothing method

Q3. Which of the following falls in the category of occupational health hazards?

- a) Chemical Hazards.
- b) Ergonomic Hazards.
- c) Physical Hazards.
- d) All of the above.

Q4. Which of the following forecasting technique includes the participation of employees, managers within the organization and industry experts?

- a) Expert's opinion
- b) Salesforce Survey
- c) Consumer survey
- d) Delphi method



Q5. Breakeven point Indicates:

- a) Recovery of fixed cost
- b) Recovery of variable cost
- c) Both A and B
- d) Recovery of fixed cost, variable cost and margin of safety

Q6. Employee PF act is applicable to any establishment having:

- a) 20 or more people
- b) 100 or more people
- c) 10 or more people
- d) 50 or more people

Q7. ESI act introduced in:

- a) 1950
- b) 1948
- c) 1979
- d) None of the above

Q8. Quality circle is a participative management system.

- a) True
- b) False

Q9. Which of the following is an advantage of 5S?

- a) Quality
- b) Productivity
- c) Time saving
- d) All of the above

Q10. Which of the following is not included under the definition of wages given under the Payment of Wages Act, 1936?

- a) Basic wage
- b) Dearness Allowance
- c) Incentive
- d) Gratuity



BHARTIYA SKILL DEVELOPMENT UNIVERSITY

Section – B

04X04 = 16 Marks

- Q11. Explain 5S.
- Q12. Write short note on Break even analysis.
- Q13. What do you mean by demand pattern?
- Q14. Explain OT principles.

Section – C

04X06 = 24 Marks

- Q15. Explain CLRA.
- Q16. What is Bathtub curve?
- Q17. Explain any 6 PPE.
- Q18. Explain Kaizen.

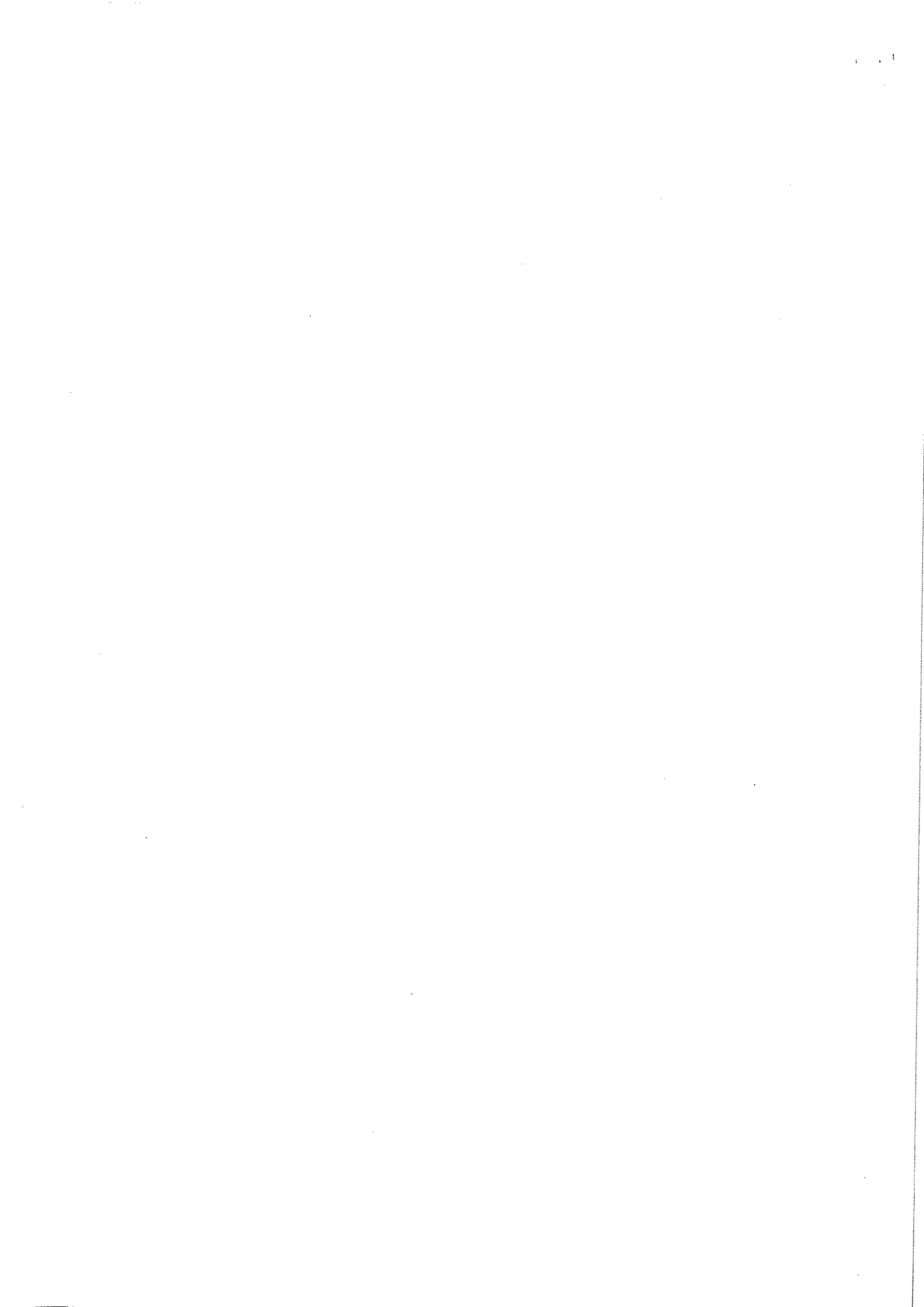



School of Automotive Skills
Session: 2021-22 (Winter Semester)
B. Voc. Program, 5th Semester,
End-Sem. Examination

Course Code: AUT1503

Time: 2 Hour

Course Name: Workshop Management

Max. Marks: 50

Instruction:

1. Answer all questions from section – A, each question carries one mark.
2. Attempt all questions from section – B, each question carries four marks.
3. Answer all questions from section – C, each question carries six marks.

Section – A

01X10 = 10 Marks

Q1. What does A in CLRA stands for?

- a) Abolition
- b) Asylum
- c) Abort
- d) None of the above

Q2. Which of the following forecasting methods takes a fraction of forecast error into account for the next period forecast?

- a) Simple moving average method
- b) Moving average method
- c) Weighted moving average method
- d) Exponential smoothing method

Q3. Which of the following falls in the category of occupational health hazards?

- a) Chemical Hazards.
- b) Ergonomic Hazards.
- c) Physical Hazards.
- d) All of the above.

Q4. Which of the following forecasting technique includes the participation of employees, managers within the organization and industry experts?

- a) Expert's opinion
- b) Salesforce Survey
- c) Consumer survey
- d) Delphi method

Ans. Set A



Q5. Breakeven point indicates:

- a) Recovery of fixed cost
- b) Recovery of variable cost
- c) Both A and B
- d) Recovery of fixed cost, variable cost and margin of safety

Q6. Employee PF act is applicable to any establishment having:

- a) 20 or more people
- b) 100 or more people
- c) 10 or more people
- d) 50 or more people

Q7. ESI act introduced in:

- a) 1950
- b) 1948
- c) 1979
- d) None of the above

Q8. Quality circle is a participative management system.

- a) True
- b) False

Q9. Which of the following is an advantage of 5S?

- a) Quality
- b) Productivity
- c) Time saving
- d) All of the above

Q10. Which of the following is not included under the definition of wages given under the Payment of Wages Act, 1936?

- a) Basic wage
- b) Dearness Allowance
- c) Incentive
- d) Gratuity



Q11. Explain 5S.

Ans: 5S is considered as the Foundation for improving the activities in the workforce by creating a work environment that is safe, hygienic, satisfying, and well organized to help in reducing waste and increasing productivity.

1. Sort: Sorting all the unnecessary items from the workplace, placing the items either in the place that it needed or storing them in place of storage for future or removing it from the facility.
 - Decide what you need
 - Remove unnecessary clutter
 - All tools, gauges, materials, classified and then stored
 - Remove items which are broken, unusable or only occasionally used
2. Set in Order: After sorting all the essential items, a place needs to be assigned to each of them. This needs to be done in a way as to make each item as readily available as possible when required.

Organise layout of tools and equipment

- Designated locations
 - Use tapes and labels
 - Ensure everything is available as it is needed and at the “point of use”
3. Shine: The workplace should be kept as clean as possible along with proper maintenance of the substance by changing the lubricants, products if required.
 - Create a spotless workplace
 - Identify and eliminate causes of dirt and grime – remove the need to clean
 - Sweep, dust, polish and paint
 4. Standardize: All processes that are followed in the workplace should be standardized so that everyone follows the same procedure all the time. Following a similar process flow will help to cut down on the risk of defects and reduce the amount of time each task takes.
 - Generate a maintenance system for the first three
 - Develop procedures, schedules, practices
 - Continue to assess the use and disposal of items
 - Regularly audit using checklists and measures of housekeeping
 - Real challenge is to keep it clean
 5. Sustain: Sustaining the changes made in the previous four steps requires proper planning and attention.
 - Driving force behind all 5S
 - Means inculcate courtesy & good habits
 - Make it a way of life
 - Part of health and safety
 - Involve the whole workforce
 - Develop and keep good habits



Q12. Write short note on Break even analysis.

Ans;

A breakeven analysis is used to determine how much sales volume your business needs to start making a profit.

- The breakeven analysis is especially useful when you're developing a pricing strategy, either as part of a marketing plan or a business plan.
- In economics & business, specifically cost accounting, the break-even point (BEP) is the point at which cost or expenses and revenue are equal: there is no net loss or gain, and one has "broken even".
- Total cost = Total revenue = B.E.P.

Break-Even Analysis

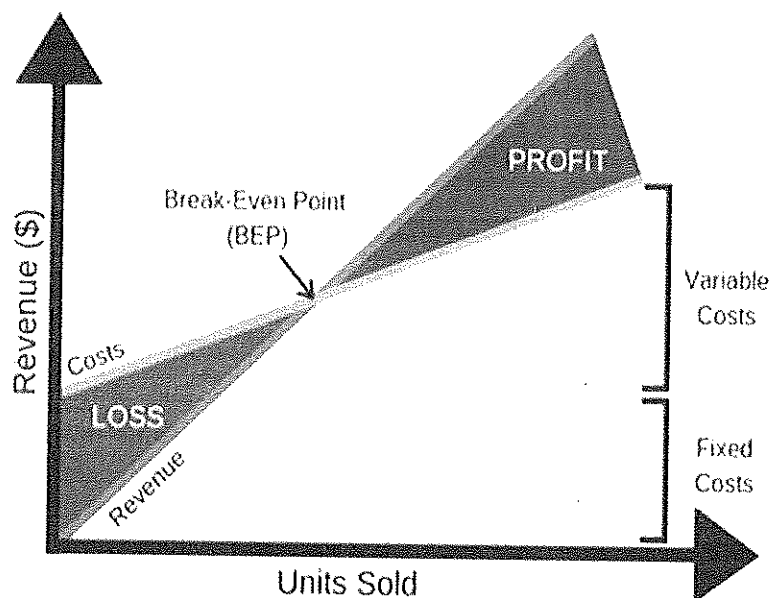

Q13. What do you mean by demand pattern?

Ans:

Demand Patterns:

When we plot our historical product demand, the following patterns can often be found:

Trend – A trend is consistent upward or downward movement of the demand. This may be related to the product's life cycle.

Cycle – A cycle is a pattern in the data that tends to last more than one year in duration. Often, they are related to events such as interest rates, the political climate, consumer confidence or other market factors.



BHARTIYA SKILL DEVELOPMENT UNIVERSITY

Seasonal – Many products have a seasonal pattern, generally predictable changes in demand that are recurring every year. Fashion products and sporting goods are heavily influenced by seasonality.

Irregular variations – Often demand can be influenced by an event or series of events that are not expected to be repeated in the future. Examples might include an extreme weather event, a strike at a college campus, or a power outage.

Random variations – Random variations are the unexplained variations in demand that remain after all other factors are considered. Often this is referred to as noise.

Q14. Explain OT principles.

Ans: Overtime (OT) Principles.

- ❖ Three Rules -
 - ✓ No OT
 - ✓ If happening, then restrict within the prescribed limit
 - ✓ Payment with double wages
- ❖ Reasons for OT -
 - a) Clients Requirement
 - b) Shortage of Manpower

Section – C

04X06 = 24 Marks

Q15. Explain CLRA.

Ans: Contract Labour Regulation & Abolition Act (CLRA).

- Applicability: - It applies to the site where total manpower (direct & indirect) deployment reaches to the threshold limit. For example: - Haryana, Uttar Pradesh, Mumbai, Rajasthan – 50, West Bengal, Gujrat - 10, Andhra Pradesh - 5, Rest of locations – 20 etc.
- 3 Legal Entities under CLRA - Principal Employer (PE/Client), Main Contractor (CBRE) & Sub contractor (Vendors)
- 2 Important documents under CLRA: -
 - Registration Certificate (RC) – To be taken by PE/Client
 - Labor License (LL) – To be taken by Main Contractor /CBRE or Sub contractor (Vendors)
- 3 pre requisite documents required for LL: -
 - Form 5 (in original copy) and this should be uploaded in the website of client where ever on line processing has begun for e.g. Haryana, Maharashtra, Rajasthan & Kolkata
 - Agreement (soft copy)
 - RC with annexure depicting the name of CBRE or its Vendors
- Renewal of LL within 30 days before its expiry except in Maharashtra where it is 60 Days



BHARTIYA SKILL DEVELOPMENT UNIVERSITY

- Records and registers to be maintained: -
 - Register of Workers
 - Employment card
 - Muster Roll
 - Register of Wages
 - Register of Deduction
 - Register of Fines
 - Register of Advances
 - Register of overtime
 - Wage slips
 - Service Certificate
- Returns - Half Yearly Returns to be filed by Contractors and Annual returns is to be filed by PE. The statutory due dates of half yearly returns is 30th January and 30th July, every year.
- Display - To display an abstract of the Acts and Rules in English and in regional language

Q16. What is Bathtub curve?

Ans: The failure rate is expected to vary over the life of a product –‘Bathtub Curve’

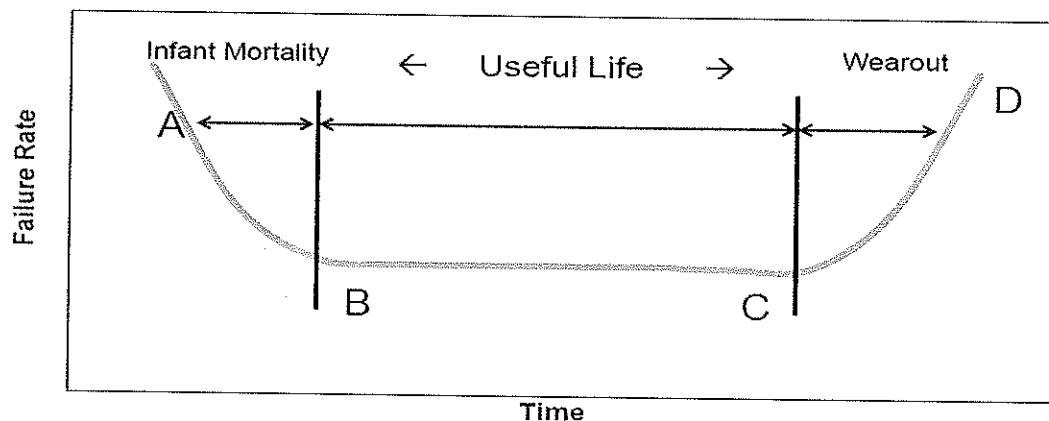

A-B Early Failure / Infant mortality / Debugging / Break-in

•‘Teething’ problems. Caused by design/material flaws

Eg: Joints, Welds, Contamination, Misuse, Misassemble

B-C Constant Failure / Useful life.

•Lower than initial failure rate and more or less constant until end of life

C-D End of life failure / Wear out phase.

•Failure rate rises again due to components reaching end of life

Eg: Corrosion, Cracking, Wear, Friction, Fatigue, Erosion, Lack of PM

Q17. Explain any 6 PPE.

Ans: PPE refers to the equipments that will protect the user against health or safety risks at work. It can include items such as safety helmets, gloves, eye protection, high-visibility clothing, safety footwear, safety harnesses etc. It also includes respiratory protective equipment (RPE).



BHARTIYA SKILL DEVELOPMENT UNIVERSITY

- Masks - A mask is an object normally worn on the face for protection.
- Helmet - A helmet is worn to protect the head from injuries. More specifically, a helmet aids the skull in protecting the human brain.
- Hand Protection - Hand protection is protective gear for the hands, which comes in many types depending upon the threat that is to be reduced. The threats can be chemicals, contamination and infection, electricity shock, mechanical hazards etc.
Hand protector equipment are gloves, grips, guards etc.
- Foot/Leg Protection - Foot/Leg protection is protective gear for the leg, which comes in many types depending upon the threat that is to be reduced. The threats can be chemicals, contamination and infection, electricity shock, mechanical hazards, etc.
Foot protector equipment are safety footwear, knee guards etc.
- Eye Protection - Eye protection is a protective gear for the eyes, which comes in many types depending upon the threat that is to be reduced. The threats can be particles, light, wind blast, heat, sea spray or some type of ball used in sports.
- Hearing/Ear Protection- Ear protection refers to devices used to protect the ear, either externally from elements such as cold, intrusion by water and other environmental conditions, debris, or specifically from noise. High levels of exposure to noise may result in noise-induced hearing loss. Measures to protect the ear are referred to as hearing protection, and devices for that purpose are called hearing protection devices. Such as earplug, earmuffs, ear pads/earflaps etc.

Q18. Explain Kaizen.

Ans: Kaizen means "improvement".

It is a Japanese workplace philosophy which focuses on making continuous small improvements which keep a business at the top of its field.

The foundation of Kaizen was laid in Japan after the Second World War, when the country was attempting to rebuild infrastructure and rethink many systems.

Several American experts on workplace improvement including W. Edwards Deming and Joseph Juran came to Japan to lecture and teach.

Using information from these individuals regarding the TWI (Training Within Industry) programs, the concept of Kaizen began to be formed and it took off in the 1950s.

Kizen Principles

- The first is a heavy reliance on teamwork, in which everyone's opinion is valued and considered.
- Workers also have strong personal discipline, and morale in factories must improve under kaizen.



BHARTIYA SKILL DEVELOPMENT UNIVERSITY

- Workers should also be confident about offering suggestions for improvement, even when a system appears to be functioning adequately
- Kaizen recognizes that there is always room for improvement
- Finally, the system uses quality circles, worker groups who meet and work together to solve problems and come up with innovative changes.



School of Automotive Skills

Session: 2021-22 (Winter Semester)

B. Voc. Program, 5th Semester,

End-Sem. Examination

Course Code: AUT1503

Time: 2 Hour

Course Name: Workshop Management

Max. Marks: 50

Instruction:

1. Answer all questions from section – A, each question carries one mark.
2. Attempt all questions from section – B, each question carries four marks.
3. Answer all questions from section – C, each question carries six marks.

Section – A

01X10 = 10 Marks

Q1. MTBF refers to the average time within failures:

- a) True
- b) False

Q2. Maternity benefits act was introduced in?

- a) 1962
- b) 1950
- c) 1961
- d) 2000

Q3. ESI act introduced in?

- a) 1950
- b) 1948
- c) 1979
- d) None of the above

Q4. Which of the following is an inventory control method?

- a) ABC analysis
- b) Break even analysis
- c) Quality circle
- d) None of the above



Q5. Breakeven point graph is drawn between:

- a) Overhead cost and fixed cost
- b) Volume of production and income
- c) Material cost and labor cost
- d) None of the above

Q6. Child labor act introduced in:

- a) 1920
- b) 1986
- c) 1987
- d) None of the above

Q7. CLRA act introduced in:

- a) 1950
- b) 1948
- c) 1979
- d) None of the above

Q8. ABC analysis full form is:

- a) At best control
- b) Always better control
- c) Average better control
- d) None of the above

Q9. 5S is defined as a housekeeping technique used to establish and maintain a productive and quality environment in an organization.

- a) True
- b) False

Q10. Which of the following forecasting technique includes the participation of employees, managers within the organization and industry experts?

- a) Expert's opinion
- b) Salesforce Survey
- c) Consumer survey
- d) Delphi method



BHARTIYA SKILL DEVELOPMENT UNIVERSITY

Section – B

04X04 = 16 Marks

Q11. What are the advantages of adding vehicle service information to workshop management software?

Q12. What are your responsibilities as an employee to ensure better EHS?

Q13. Explain reliability?

Q14. What is the concept of zero defect?

Section – C

04X06 = 24 Marks

Q15. Explain fishbone analysis and quality circle.

Q16. Explain qualitative methods of forecasting.

Q17. What is Child Labor (Regulation & Abolition) Act?

Q18. What are the objectives of Maintainability?

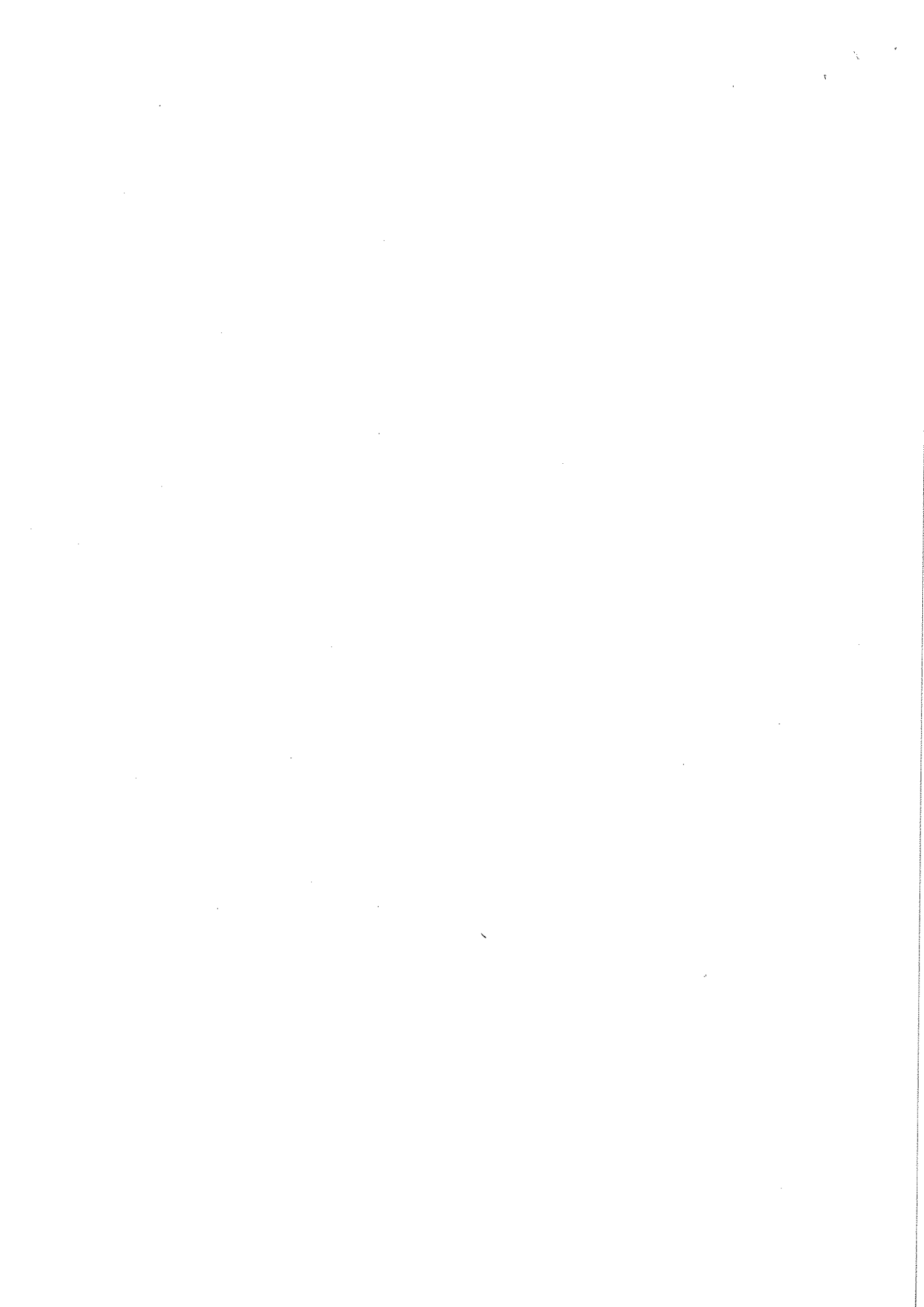



A.V. Set B

School of Automotive Skills
Session: 2021-22 (Winter Semester)
B. Voc. Program, 5th Semester,
End-Sem. Examination

Course Code: AUT1503

Time: 2 Hour

Course Name: Workshop Management

Max. Marks: 50

Instruction:

1. Answer all questions from section – A, each question carries one mark.
2. Attempt all questions from section – B, each question carries four marks.
3. Answer all questions from section – C, each question carries six marks.

Section – A

01X10 = 10 Marks

Q1. MTBF refers to the average time within failures:

- a) True
- b) False

Q2. Maternity benefits act was introduced in?

- a) 1962
- b) 1950
- c) 1961
- d) 2000

Q3. ESI act introduced in?

- a) 1950
- b) 1948
- c) 1979
- d) None of the above

Q4. Which of the following is an inventory control method?

- a) ABC analysis
- b) Break even analysis
- c) Quality circle
- d) None of the above



Q5. Breakeven point graph is drawn between:

- a) Overhead cost and fixed cost
- b) Volume of production and income
- c) Material cost and labor cost
- d) None of the above

Q6. Child labor act introduced in:

- a) 1920
- b) 1986
- c) 1987
- d) None of the above

Q7. CLRA act introduced in:

- a) 1970
- b) 1948
- c) 1979
- d) None of the above

Q8. ABC analysis full form is:

- a) At best control
- b) Always better control
- c) Average better control
- d) None of the above

Q9. 5S is defined as a housekeeping technique used to establish and maintain a productive and quality environment in an organization.

- a) True
- b) False

Q10. Which of the following forecasting technique includes the participation of employees, managers within the organization and industry experts?

- a) Expert's opinion
- b) Salesforce Survey
- c) Consumer survey
- d) Delphi method



Q11. What are the advantages of adding vehicle service information to workshop management software?

Ans:

1. Save History and Time

Every garage manages a lot of vehicle repairs in a day, and it becomes tough for them to keep track of every detail. With auto repair software everything becomes simple. It tracks all the vehicles details including service history and digital inspections which are all stored in the cloud, and garage staff and management can retrieve any information they desire in just a couple of clicks.

It reduces the time taken for various regular shop operations as everything will be automated. Estimating, diagnosing, repairing vehicles, ordering the parts are some of the simple yet time consuming tasks that are replaced with software.

2. Reduces Paperwork

Garages revolve around paperwork, and it is exhausting. Everything about a vehicle should be entered in a book, job cards, the inventory, estimations, invoicing, etc. there are a lot of things that are paper based in a garage. All of these things can be quickly done and handled with the help of automotive workshop software.

3. Automate your Auto Repair Shop

Every auto shop has multiple things to manage at any given time, just like juggling balls in the air or at times it feels that way. There are things you can do to change that feeling like using a system with automated processes and functions, for example you can automate your stock control, service reminders, marketing campaigns, message broadcast, job status, supplier integration, customer experience and many more.

4. Better Communication among Staff

Using software to manage auto shop enables you to share information across your business quickly and easily and it doesn't matter what device you're on. Each employee will see their tasks for the day, week or month and can manage and complete these with confidence knowing there will be no duplication or missing data as all information and communication is on a single platform.

Q12. What are your responsibilities as an employee to ensure better EHS?

Ans:

Responsibilities as an employee :

- As a worker, you should report work-related cases resulting in injury and illnesses in case your employer fails or declines to do so. The process has it that workers can inform OSHA (Occupational Safety and Health Administration) anytime in case something hazardous happened in the workplace.



- It is an employee's responsibility to assess working conditions as to whether the workplace is unsafe and unhealthy or otherwise, so necessary actions can be performed by OSHA in order to protect the safety and the common good of the majority.
- The employee has the responsibility of confirming whether the company he or she is engaged with have ever been inspected by OSHA, and if it isn't, he or she can ask how likely it can be done in order to promote workplace health and safety.

Q13. Explain reliability?

Ans: Reliability definition:

Generally defined as the ability of a product to perform, as expected, over certain time.

Reliability is performance over time, probability that something will work when you want it to work.

The Reliability definition has four important elements:

- Probability (A value between 0 and 1, number of times that an event occurs (success) divided by total number trials)

e.g. probability of 0.91 means that 91 of 100 items will still be working at stated time under stated conditions

- Performance (Some criteria to define when and how product fails, which also describes what is considered to be satisfactory system operation)

e.g. amount of beam collisions, etc.

- Time (system working until time (t), used to predict probability of an item surviving without failure for a designated period of time)

- Operating conditions

These describe the operating conditions (environmental factors, humidity, vibration, shock, temperature cycle, operational profile, etc.) that correspond to the stated product life.

Q14.What is the concept of zero defect?

Ans:

Quality defects have significant costs associated with them – some of the most obvious being money, time, resources, and lost reputation.

- Zero defect, according to its originator James F. Halpin, is a concept which promotes a constant, conscious desire to do a job right, the first time.
- It is essentially a management technique in which the job is presented as a challenge to the individual worker. At the same time, he is provided with all the facilities to enable him to meet the challenge.
- Those who achieve outstanding results receive public recognition, which motivate them to excel in their respective jobs, and acquire pride in their workmanship.



Principles of zero defects

1. Quality is conformance to requirements:
 - Every product or service has a requirement: a description of what the customer needs. eg. In common parlance, an inexpensive disposable pen is a lower quality item than a gold-plated fountain pen. In the technical sense of Zero defect, the inexpensive disposal pen is a quality product if it meets requirement: it writes, does not skip nor clog under normal use, and lasts the time specified.
2. Defect prevention is preferable to quality inspection and correction:
 - It is always less troublesome, more certain and less expensive to prevent defects than to discover and correct them.
 - Zero defect is the quality standard
 - Quality is measured in monetary terms – the price of nonconformance (PONC)

Section – C

04X06 = 24 Marks

Q15. Explain fishbone analysis and quality circle.

Ans:

A cause-and-effect analysis generates and sorts hypotheses about possible causes of problems within a process by asking participants to list all of the possible causes and effects for the identified problem

Cause-and-effect diagrams can reflect either causes that block the way to the desired state or helpful factors needed to reach the desired state.

The fishbone analysis is mostly used by teams at the deepen stage of the remodelling process. It does not tell which is the root cause, but rather possible causes.

Steps

1. Draw a horizontal line (central spine) near the centre of a page. Label one end with the problem or goal.
2. Collect information from the participants on aspects of the situation. For the main aspects, draw lines off the central spine. Aspects related to a particular main spine are then drawn off that spine.
3. Set priorities. Select the most important main spine then rank the items drawn off that spine. Continue this process with the other main spines.
4. If the top priority spine has no branches, use this aspect of the situation for the next step in problem solving.



Quality Circles

1. A quality circle is a volunteer group composed of employees, who are trained to identify, analyse and solve work-related problems and present their solutions to management.
2. This improves the performance of the organization, while also motivating and enriching the work of employees.
3. First established in Japan in 1962 in the Nippon Wireless and Telegraph Company, it quickly became popular and spread to more than 35 companies in the first year.

Q16. Explain qualitative methods of forecasting.

Ans:

- Qualitative methods of forecasting:

Qualitative type of forecasting methods are used for strategic level purposes usually on a longer horizon for facilitating decision making. These include the following techniques:

1. **Grassroots forecasting:** In this type of forecasting, people at the grassroots level in an organisation, i.e. those who are in direct contact with customers are taken as good source of information for inputs to forecasting process. For example, sales staff or customer service personnel have data related to changing pattern of consumption of customers, performance of competitive products, overall distribution of market share, etc. These data could judiciously be used for forecasting purposes.
2. **Historical analogy:** In this type of forecasting, life cycles of similar products and services in the market are compared for getting insights to future developments. It is based on the assumption that demand pattern at each stage of life cycle for future events would follow similar pattern as that of past events.
3. **Customer surveys:** Companies also solicit inputs from customers as they are the ones who control the demand for any product. Customer surveys help companies to get critical inputs on various aspects of a product. They are usually used for short to medium range forecasting purposes
4. **Executive opinions:** Single person might have overseen some important aspects that need attention. To overcome this limitation, this type of forecasting uses group of experts from different fields as marketing, sales, operations, etc., in collectively developing a forecast. The main objective of this method is to use the creativity talents of its members for better forecast. This method has the advantage that experts bring with them considerable knowledge and opinions on a problem under consideration.
5. **Delphi method:** It is an iterative group process intended to achieve a consensus forecast. In this method, the coordinator prepares a comprehensive questionnaire related to the problem under study. He circulates the questionnaire to a panel of experts from diverse backgrounds both inside and outside the organisation, eliciting



BHARTIYA SKILL DEVELOPMENT UNIVERSITY

their response. Response of the experts are kept anonymous so that honest opinions from them are obtained. Subsequently, the coordinator compiles, edits and summarises all the responses to extract meaningful information from it and then prepares new questionnaire for the problem under study. He circulates the new questionnaire to the same set of experts again for responses. This process is continued until satisfactory overall prediction is obtained from experts. Delphi method is particularly useful for technological forecasting purposes.

Q17. What is Child Labor (Regulation & Abolition) Act?

Ans:

Child Labour (Regulation & Abolition) Act.

- Applicability – In applies to the whole of India in all shops, commercial establishments and factories of any nature.
- Child Labor - Child means a person who has not completed his fourteen years of age.
- Notice to be displayed - Every site shall display the abstract of the Act of 1986 at conspicuous place accessible and visible to all.
- Penalty – Imprisonment up to 1 years and fine up to Rupees Twenty Thousand or both.

Q18. What are the objectives of Maintainability?

Ans:

- 1.To influence design to achieve ease of maintenance thus reducing maintenance time & cost.
- 2.To estimate the downtime for maintenance which, when compared with allowable downtime, determines whether redundancy is required to provide acceptable continuity of acritical function.
- 3.To estimate system availability by combining maintainability data with reliability data.
- 4.To estimate the man-hours and other resources required for performing maintenance, which are useful for determining the costs of maintenance and for maintenance planning.

