



BHARTIYA SKILL DEVELOPMENT UNIVERSITY

Registration No.:

School of Manufacturing Skills
Session: 2020-21 (Summer Semester)
B. Voc. Program, I Semester,
End-Sem. Examination

Set A

Course Code: SMS1101

Course Name: Assembly & Measuring

Time: 2 Hour

Max. Marks: 50

Instructions:

1. Attempt all questions.
2. Section A contains 10 Questions. Each question carries 1 Mark.
3. Section B contains 04 Questions. Each question carries 4 Marks.
4. Section C contains 04 Questions. Each question carries 6 Marks.

Section – A

10X01 = 10 Marks

1. For a properly lubricated chain, efficiency is from-
 - a) 70-80%
 - b) 90-92%
 - c) 80-90%
 - d) 96-98%
2. Non-metallic gaskets are made up of-
 - a) Wood & Brass
 - b) Aluminium & Rubber
 - c) Rubber & Asbestos
 - d) All of the above
3. Example of semisolid lubricant is-
 - a) Mineral oil
 - b) Grease
 - c) Graphite
 - d) Vegetable oil
4. Plunger dial indicators are not used for-
 - a) Inspecting surface for flatness.
 - b) Aligning Workpiece
 - c) Inspecting shaft roundness
 - d) Measuring boring diameter



BHARTIYA SKILL DEVELOPMENT UNIVERSITY

5. V-belts have a _____ cross-section.
- Circular
 - Triangular
 - Trapezoidal
 - Rectangular
6. Outside Taper can be checked by-
- Taper Plug Gauge
 - Outside Micrometer
 - Ring Gauge
 - Taper Ring Gauge
7. "Stem and stylus must be at the right angle to the measurement surface." This sentence suit for-
- Puppet dial test indicator
 - Plunger Type Test Indicator
 - Sine Bar
 - None of the above
8. Standard Temperature for measurement is-
- 250 C
 - 200 C
 - 180 C
 - None of the above
9. Least size is available in Slip Gauge block set which you have used-
- 1.0005
 - 1.05
 - 1.050
 - 1.005
10. Radius gauge is the type of.
- Form gauge.
 - Limit gauge.
 - Dimensional gauge
 - Both form and limit gauge.

Section – B

04X04 = 16 Marks

11. Write the name of the following parts.

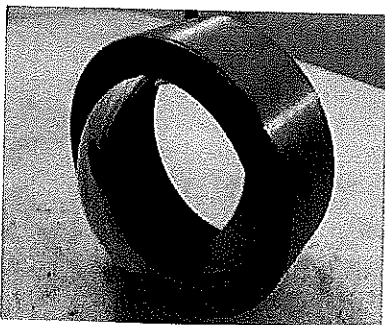

A



B

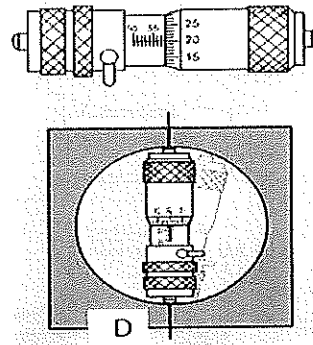
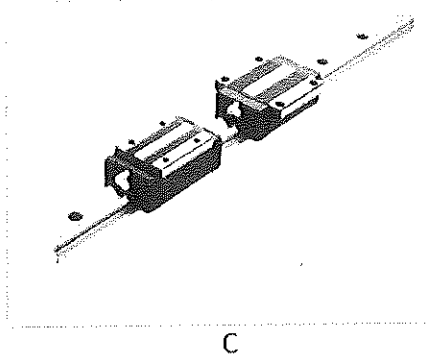

12. What is the difference between accuracy and precision?
13. Write down the advantages and disadvantages of V-belt over a Flat belt drive.
14. Which factors should we consider to select a measuring tool?

Section – C

04X06 = 24 Marks

15. What is the importance of Least count and Calculate the least count of Bevel Protractor?
16. Write down the names of any five from the picture given below.

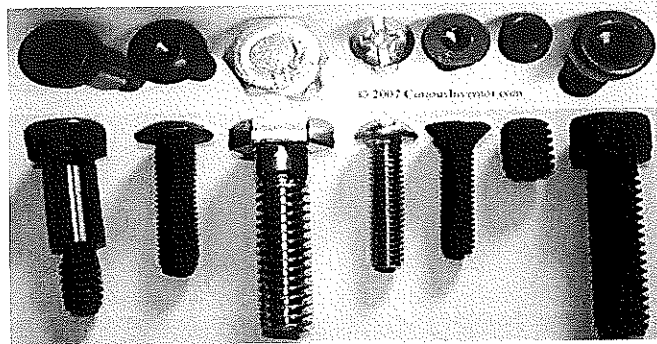

17. Explain any three.
 - a) Calibration of Measuring Instruments
 - b) Surface table
 - c) Geometrical Dimensions & Tolerances
 - d) Dial calliper
18. (A) What is Dowell pin? Write any two advantages and disadvantages of a deep groove ball bearing.
 (B) What is the use of spring washer? Give the difference between a direct and indirect measurement with examples.



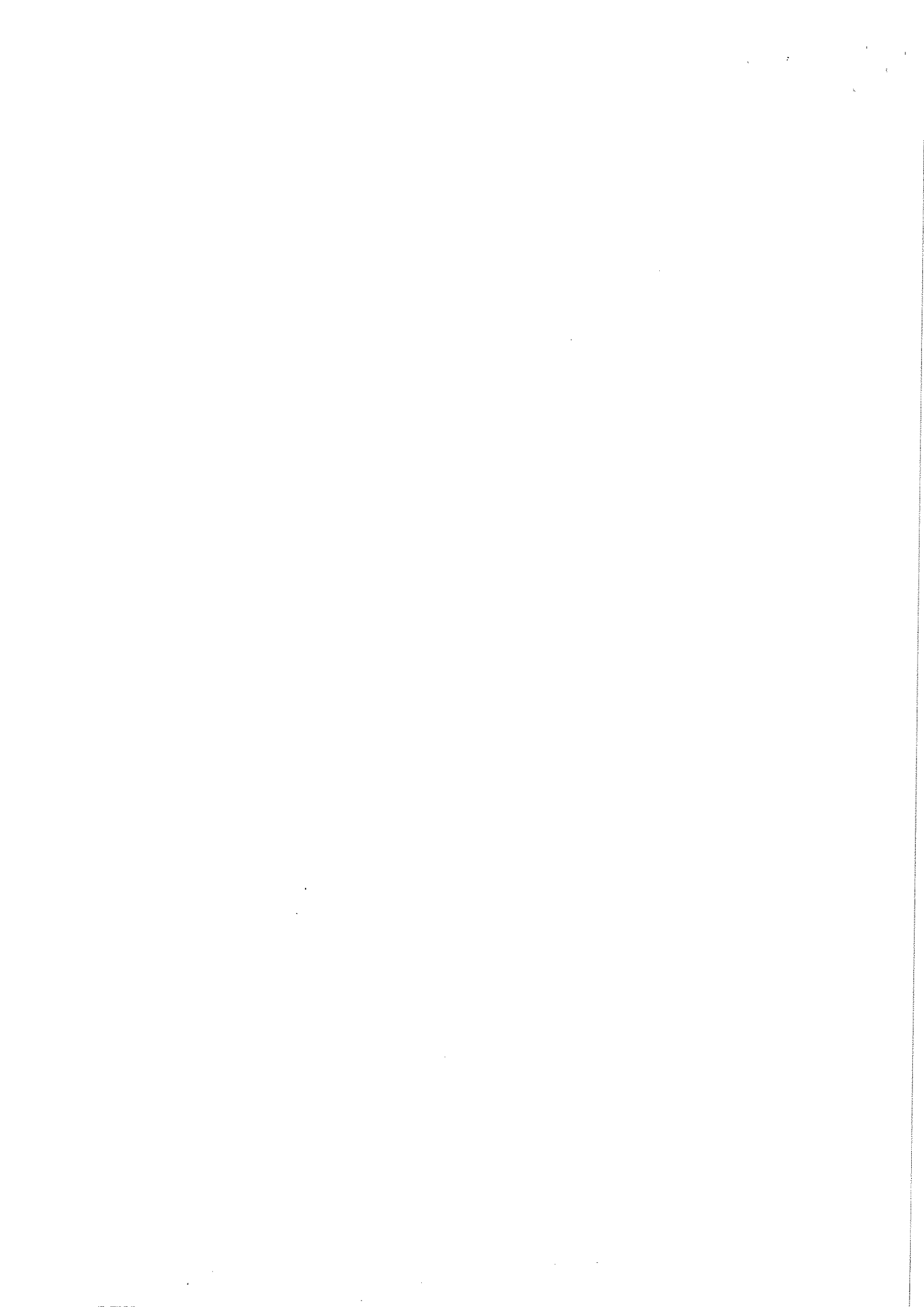



BHARTIYA SKILL DEVELOPMENT UNIVERSITY

Registration No.:

School of Manufacturing Skills
Session: 2020-21 (Summer Semester)
B. Voc. Program, I Semester,
End-Sem. Examination

Course Code: SMS1101

Course Name: Assembly & Measuring

Time: 2 Hour

Max. Marks: 50

Answer Key

Section – A

10X01 = 10 Marks

1. For a properly lubricated chain, efficiency is from-
 - a) 70-80%
 - b) 90-92%
 - c) 80-90%
 - d) **96-98%**
2. Non-metallic gaskets are made up of-
 - a) Wood & Brass
 - b) Aluminium & Rubber
 - c) **Rubber & Asbestos**
 - d) All of the above
3. Example of semisolid lubricant is-
 - a) Mineral oil
 - b) **Grease**
 - c) Graphite
 - d) Vegetable oil
4. Plunger dial indicators are not used for-
 - a) Inspecting surface for flatness.
 - b) Aligning Workpiece
 - c) Inspecting shaft roundness
 - d) **Measuring boring diameter**
5. V-belts have a _____ cross-section.
 - a) Circular
 - b) Triangular
 - c) **Trapezoidal**
 - d) Rectangular



BHARTIYA SKILL DEVELOPMENT UNIVERSITY

6. Outside Taper can be checked by-
- a) Taper Plug Gauge
 - b) Outside Micrometer
 - c) Ring Gauge
 - d) **Taper Ring Gauge**
7. "Stem and stylus must be at the right angle to the measurement surface." This sentence suit for-
- a) Puppet dial test indicator
 - b) **Plunger Type Test Indicator**
 - c) Sine Bar
 - d) None of the above
8. Standard Temperature for measurement is-
- a) 25 C
 - b) **20 C**
 - c) 18 C
 - d) None of the above
9. Least size is available in Slip Gauge block set which you have used-
- a) 1.0005
 - b) 1.05
 - c) 1.050
 - d) **1.005**
10. Radius gauge is the type of.
- a) **Form gauge.**
 - b) Limit gauge.
 - c) Dimensional gauge
 - d) Both form and limit gauge.

Section – B

04X04 = 16 Marks

11. Write the name of the following parts.



A

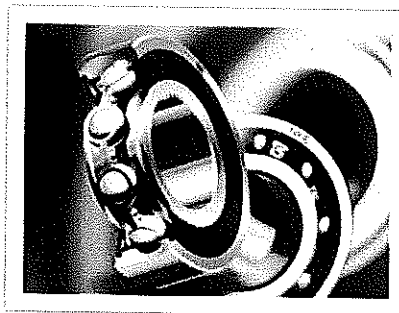

B

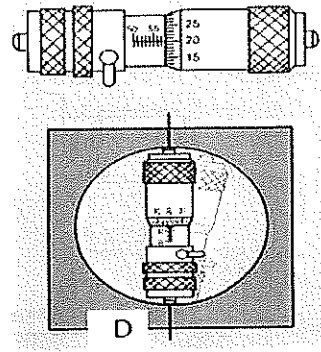
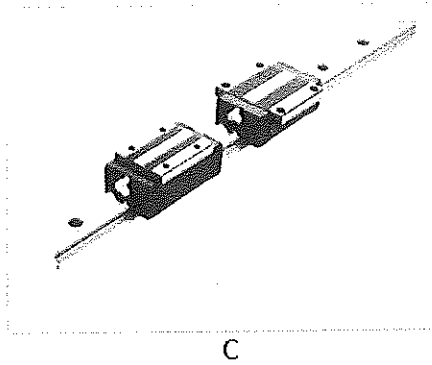

- A. Plain Bearing
- B. Deep Groove Ball Bearing
- C. Linear Guideways
- D. Two-Point Contact Micrometre

12. What is the difference between accuracy and precision?

Ans. Accuracy is how close a measured value is to the actual (true) value.
Precision is how close the measured values are to each other.

13. Write down the advantages and disadvantages of V-belt over a Flat belt drive.

Advantages

- Friction is high due to wedge action, results in power transmitting capacity.
- Slip is negligible due to wedge action.
- Can operate vertically also.

Disadvantages

- Cost is high, creep is high.
- Construction is complicated.

14. Which factors should we consider to select a measuring tool?

- Ans:-** (1) Tolerances of a given size
(2) Range of given dimension
(3) Availability of measuring instruments
(4) Time consumption in measurements

Section – C

04X06 = 24 Marks

15. What is the importance of Least count and Calculate the least count of Bevel Protractor?

Answer: - Importance of least count: -

1. Without least count, we cannot take Measurement.
2. To define any kind of reading in measuring instruments we should know the least count.
3. With the help of least count of measuring instruments, we can define the precision.

Least count of Bevel Protractor = value of one division on main scale/ Total No of division on sub scale

$$= 1/12$$

$$= 1 \times 60 / 12 \quad (\text{Because } 1^\circ = 60 \text{ minute}) = 5'$$

16. Write down the names of any five from the picture given below.

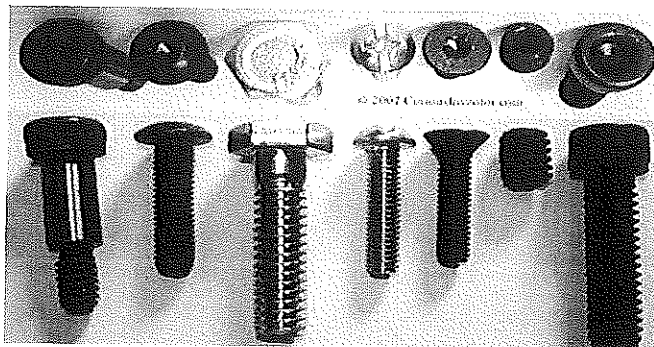

- Set screw
- Button head cap screw
- CSK screw
- Button head cap screw
- Hexa head cap screw
- Roundhead slotted cap screw

17. Explain any three.

- Calibration of Measuring Instruments
- Surface table
- Geometrical Dimensions & Tolerances
- Dial caliper

Calibration of Measuring Instruments: -

Calibration means to check the correctness of measuring instruments with a standard.

It is very important otherwise we cannot be sure about perfect measurement.

With the help of Slip gauge grade 00, we can check or calibrate the measuring instruments.

Surface plate in measuring

The surface plate is a standard base plate used for measuring. This is very precise and accurate & provide the flat datum to measure any kind of dimension. It can be made of Cast Iron and Granite. Granite Surface table is very precise and costly. It is having a very good compressive strength.

Geometrical Dimensions & Tolerances

Geometrical Dimension & Tolerance is used in drawing to control the geometrical feature is a part. With the help of GD&T, we can achieve better geometry & best fits.

There are so many geometrical symbols are used:- Like Concentricity, Parallelism, flatness, run out, total runout, Cylindrical, Eccentricity, the surface of the line, the surface of profile etc.

Dial calliper

The dial calliper is measuring instruments to check the various dimension like length, width, thickness, depth etc. It is having a least count of 0.01 mm. The dial calliper is an advance Vernier with having dial. With the help of dial calliper, we can identify the measurement variation also.

18. (A) What is Dowell pin? Write any two advantages and disadvantages of a deep groove ball bearing.

(B) What is the use of spring washer? Give the difference between a direct and indirect measurement with examples.

Ans. (A) They are short, cylindrical rods made of various materials including wood, metal, plastic. Dowell pins can be tapered, grooved, slotted.



BHARTIYA SKILL DEVELOPMENT UNIVERSITY

ADVANTAGES	DISADVANTAGES
<p>a. Relatively large size of balls, these bearings have high load carrying capacity.</p> <p>b. Due to point contact between the balls and races, frictional loss and temperature rise is less.</p>	<p>a. Not self-aligning, accurate aligning between shaft and housing bore is required.</p> <p>b. Poor rigidity compared to roller bearing.</p>

(B) During tightening, the spring washer is compressed and its teeth bite into the contacting surface of the nut on one side and the base on the other. Thus, nut gets fixed in the base. Locking is more effective when the contacting surfaces are soft.

Direct Measurement	Indirect Measurement
Direct measurement means measurement directly can taken by measuring instruments	Indirect measurement means measurement can taken by comparing with some other instruments.
Direct Measurement accurate and precise	Indirect Measurement not that much accurate and precise comparatively direct measurement.
Vernier calliper, Micrometre	Caliper, Scriber,

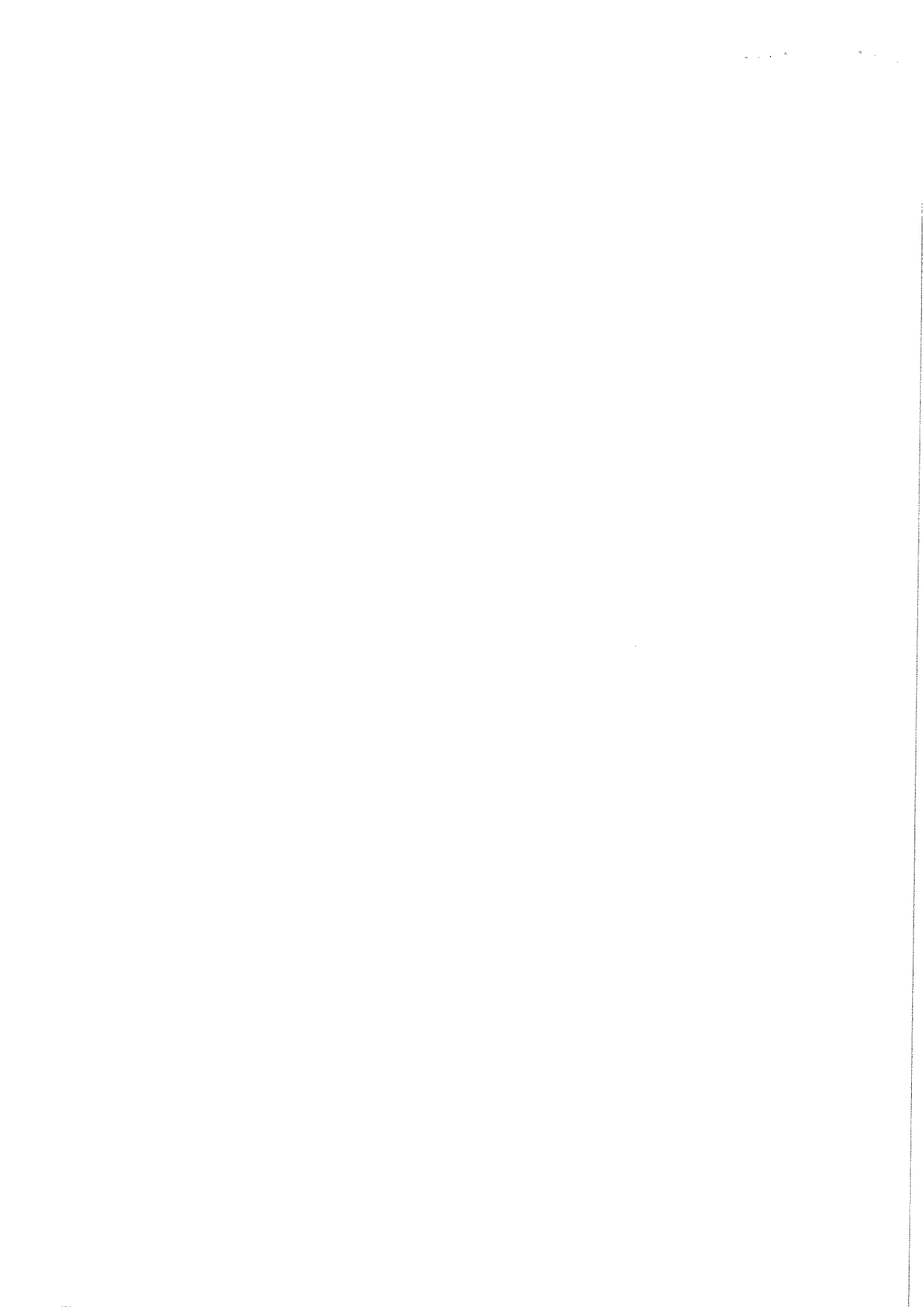



BHARTIYA SKILL DEVELOPMENT UNIVERSITY

Registration No.:

Set B
School of Manufacturing Skills
Session: 2020-21 (Summer Semester)
B. Voc. Program, I Semester,
End-Sem. Examination

Course Code: SMS1101

Time: 2 Hour

Course Name: Assembly & Measuring

Max. Marks: 50

Instructions:

1. Attempt all questions.
2. Section A contains 10 Questions. Each question carries 1 Mark.
3. Section B contains 04 Questions. Each question carries 4 Marks.
4. Section C contains 04 Questions. Each question carries 6 Marks.

Section – A

10X01 = 10 Marks

1. Which measuring instrument can be used to measure the internal diameter of 20.015 mm?
 - a) Digital Vernier callipers
 - b) Micrometre.
 - c) Hole test Micrometer
 - d) Plug gauge
2. Which one is the example of form gauge?
 - a) Feeler gauge
 - b) Micrometre
 - c) Vernier Depth gauge
 - d) None of these
3. Which one of the following is not a part of a micrometre?
 - a) Thimble
 - b) spindle
 - c) probe
 - d) Anvil
4. For Which applications, plunger dial indicators are not used?
 - a) Inspecting surface for flatness.
 - b) Aligning Workpiece
 - c) Inspecting shaft roundness
 - d) Measuring boring diameter



BHARTIYA SKILL DEVELOPMENT UNIVERSITY

5. V-belts have _____ cross-section.
 - a) Circular
 - b) Triangular
 - c) Trapezoidal
 - d) Rectangular
6. Outside Taper can be checked by-
 - a) Taper Plug Gauge
 - b) Outside Micrometer
 - c) Ring Gauge
 - d) Taper Ring Gauge
7. "Stem and stylus must be at the right angle to the measurement surface." This sentence suit for-
 - a) Puppet dial test indicator
 - b) Plunger Type Test Indicator
 - c) Sine Bar
 - d) None of the above
8. Standard Temperature for measurement is-
 - a) 25 C
 - b) 20 C
 - c) 18 C
 - d) None of the above
9. Least size is available in Slip Gauge block set which you have used: -
 - a) 1.0005
 - b) 1.05
 - c) 1.050
 - d) 1.005
10. Radius gauge is the type of-
 - a) Form gauge.
 - b) Limit gauge.
 - c) Dimensional gauge
 - d) Both form and limit gauge.

Section – B

04X04 = 16 Marks

11. What is an oil seal? Also, write any two functions of it.
12. What is the difference between accuracy and precision?
13. Write the difference between measuring instruments and gauges?
14. Which factors should we consider to select a measuring tool?



BHARTIYA SKILL DEVELOPMENT UNIVERSITY

Section – C

04X06 = 24 Marks

15. What is the importance of Least count and Calculate the least count of Bevel Protractor?
16. Write down the advantages of a Timing belt.
17. Explain any three.
 - a) Calibration of Measuring Instruments
 - b) Surface table
 - c) Geometrical Dimensions & Tolerances
 - d) Dial calliper
18. (A) Calculate the least count of Vernier calliper which has 50 divisions on a secondary scale with write down the formula.
(B). Write down the different parts of a micrometre with their application.

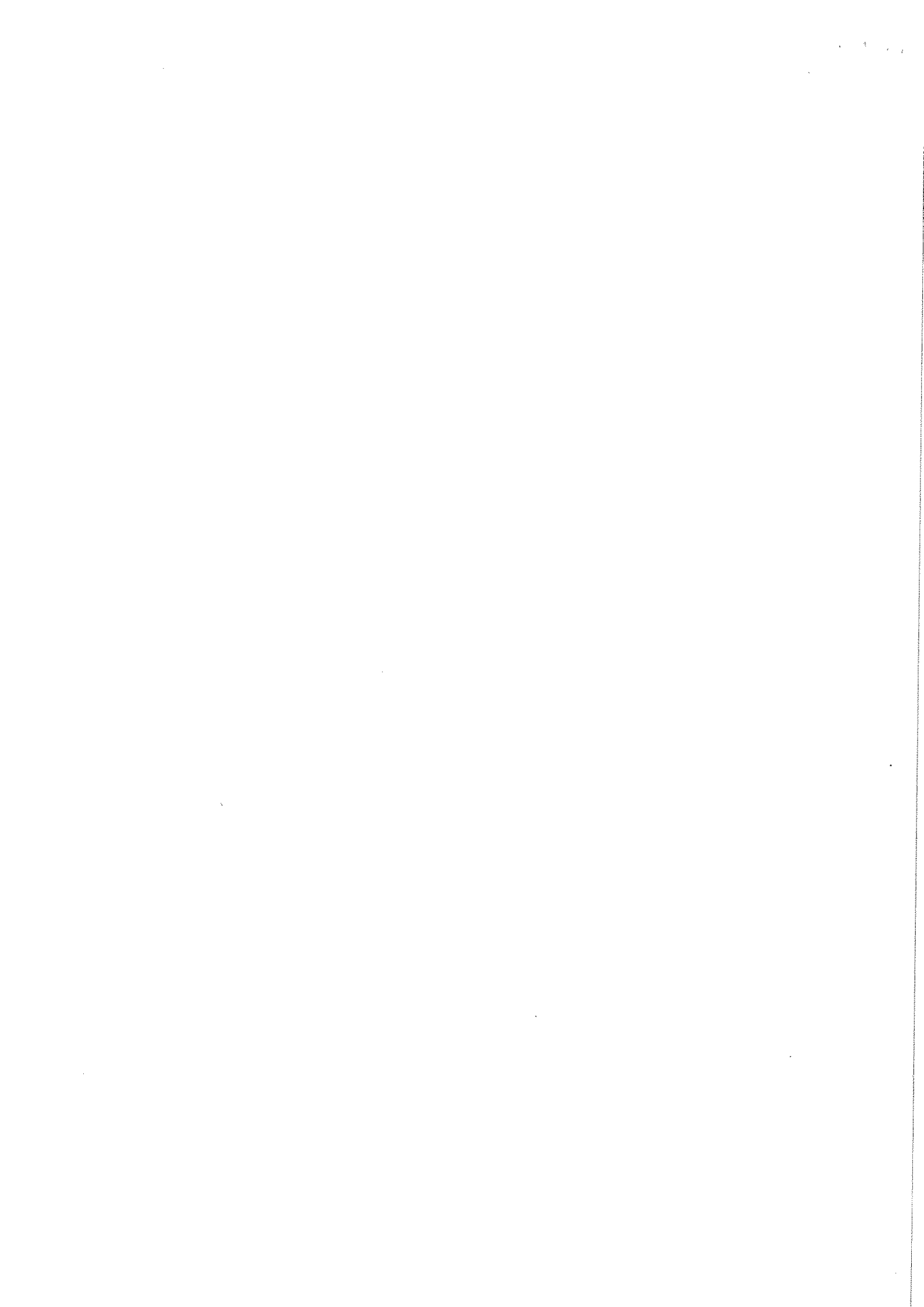



BHARTIYA SKILL DEVELOPMENT UNIVERSITY

Set - B

Registration No.:

School of Manufacturing Skills
Session: 2020-21 (Summer Semester)
B. Voc. Program, I Semester,
End-Sem. Examination

Course Code: SMS1101

Course Name: Assembly & Measuring

Time: 2 Hour

Max. Marks: 50

Answer Key

Section – A

10X01 = 10 Marks

1. Which measuring instrument can be used to measure the internal diameter of 20.015 mm?
 - a) Digital Vernier callipers
 - b) Micrometre.
 - c) **Hole test Micrometer**
 - d) Plug gauge
2. Which one is the example of form gauge?
 - a) **Feeler gauge**
 - b) Micrometre
 - c) Vernier Depth gauge
 - d) None of these
3. Which one of the following is not a part of a micrometre?
 - a) Thimble
 - b) spindle
 - c) **probe**
 - d) Anvil
4. For Which applications, plunger dial indicators are not used?
 - a) Inspecting surface for flatness.
 - b) Aligning Workpiece
 - c) Inspecting shaft roundness
 - d) **Measuring boring diameter**
5. V-belts have _____ cross-section.
 - a) Circular
 - b) Triangular
 - c) **Trapezoidal**
 - d) Rectangular



BHARTIYA SKILL DEVELOPMENT UNIVERSITY

6. Outside Taper can be checked by-
- Taper Plug Gauge
 - Outside Micrometer
 - Ring Gauge
 - Taper Ring Gauge**
7. "Stem and stylus must be at the right angle to the measurement surface." This sentence suit for-
- Puppet dial test indicator
 - Plunger Type Test Indicator**
 - Sine Bar
 - None of the above
8. Standard Temperature for measurement is-
- 25 C
 - 20 C**
 - 18 C
 - None of the above
9. Least size is available in Slip Gauge block set which you have used: -
- 1.0005
 - 1.05
 - 1.050
 - 1.005**
10. Radius gauge is the type of-
- Form gauge.**
 - Limit gauge.
 - Dimensional gauge
 - Both form and limit gauge.

Section – B

04X04 = 16 Marks

11. What is an oil seal? Also, write any two functions of it.

Ans. An oil seal is a mechanical device, which is used to prevent leakage of fluid between two machine components

Functions of the oil seal-

To prevent leakage of expensive lubricating oils from the transmission system.

To prevent the entry of foreign particles like dust or abrasive material into the operating system

12. What is the difference between accuracy and precision?

Ans. Accuracy is how close a measured value is to the actual (true) value.

Precision is how close the measured values are to each other.



BHARTIYA SKILL DEVELOPMENT UNIVERSITY

13. Write the difference between measuring instruments and gauges?

S.No.	Gauges	Measuring instruments
1.	Gauge is used to check the workpiece	Instruments are used to measure the workpiece
2.	This is used for mass production mainly	Instruments are used for buying out inspection
3.	Gauges have to fix dimension or fix Value	Instruments have variable dimension or value

14. Which factors should we consider to select a measuring tool?

- Ans:-** (1) Tolerances of a given size
(2) Range of given dimension
(3) Availability of measuring instruments
(4) Time consumption in measurements

Section – C

04X06 = 24 Marks

15. What is the importance of Least count and Calculate the least count of Bevel Protractor?

Answer: - Importance of least count: -

1. Without least count, we cannot take Measurement.
2. To define any kind of reading in measuring instruments we should know the least count.
3. With the help of least count of measuring instruments, we can define the precision.

Least count of Bevel Protractor = value of one division on the main scale/ Total No of division on the subscale

$$= 1/12$$

$$= 1 * 60 / 12 \quad (\text{Because } 1^{\circ} = 60 \text{ minute}) = 5'$$

16. Write down the advantages of a Timing belt.

Ans. When correctly tensioned, they have no slippage.

Less noise.

Lubrication is not necessary.

Needs least tension of all belts and most efficient.

17. Explain any three.

- a) Calibration of Measuring Instruments
- b) Surface table
- c) Geometrical Dimensions & Tolerances
- d) Dial caliper

Calibration of Measuring Instruments: -

Calibration means to check the correctness of measuring instruments with a standard.

It is very important otherwise we cannot sure about perfect measurement.

With the help of Slip gauge grade 00, we can check or calibrate the measuring instruments.



BHARTIYA SKILL DEVELOPMENT UNIVERSITY

Surface plate in measuring

The surface plate is a standard base plate used for measuring. This is very precise and accurate & provide the flat datum to measure any kind of dimension. It can be made of Cast Iron and Granite. Granite Surface table is very precise and costly. It is having a very good compressive strength.

Geometrical Dimensions & Tolerances

Geometrical Dimension & Tolerance is used in drawing to control the geometrical feature is a part. With the help of GD&T, we can achieve better geometry & best fits.

There are so many geometrical symbols are used:- Like Concentricity, Parallelism, flatness, run out, total runout, Cylindrical, Eccentricity, the surface of the line, the surface of profile etc.

Dial calliper

The dial calliper is measuring instruments to check the various dimension like length, width, thickness, depth etc. It is having a least count of 0.01 mm. The dial calliper is an advance Vernier with having dial. With the help of dial calliper, we can identify the measurement variation also.

18. (A) Calculate the least count of Vernier calliper which has 50 divisions on a secondary scale with write down the formula.

(B). Write down the different parts of a micrometre with their application.

Ans. (A)

Formula:

L.C = One values of smallest division on main scale / Total division on secondary scale

OR

L.C = Main scale division – Vernier scale division

Calculate the least count:

L.C = $1 / 50 = 0.02\text{mm}$

Or

L.C = $1 - 0.98 = 0.02\text{mm}$

(B) Write down the different parts of micrometer with their application.

Answer.

- **Ratchet**- used to apply constant and limited measuring force and also used for fine movement.
- **Thermal insulation pad**- does not allow transferring the body heat to the micrometre.
- **Anvil and spindle**- Anvil used to support the workpiece and create reference face and spindle create measuring face, it consists of linear and rotational motion.
- **Measuring scale**- works on the pitch principle or can be defined as one rotation of circular scale gives one division linear movement on the main scale.
- **Frame** – it is required for providing support to all components of the micrometre.



BHARTIYA SKILL DEVELOPMENT UNIVERSITY

Registration No.:

Set-A

School of Manufacturing Skills
Session: 2020-21 (Summer Semester)
B. Voc. Program, I Semester,
End-Sem. Examination

Course Code: SMS1102
Course Name: Handskills

Time: 2 Hour
Max. Marks: 50

Instructions:

1. Attempt all questions.
2. Section A contains 10 Questions. Each question carries 1 Mark.
3. Section B contains 04 Questions. Each question carries 4 Marks.
4. Section C contains 04 Questions. Each question carries 6 Marks.

Section – A

10X01 = 10 Marks

1. The drill which has taper shank should be clamped in-
 - a) Sleeve
 - b) Drill chuck
 - c) Tap wrench
 - d) Collect chuck
2. Which of the file cut configuration has the worst chip evacuation?
 - a) Straight cut
 - b) Curved cut
 - c) Diagonal
 - d) Both a & b
3. Counter boring can be done without pre-drill-
 - a) True
 - b) False
4. Which of the following tool is used to scribe the circle, radii and hole spacing when the dimensions are large?
 - a) Marking T-rule
 - b) Trammel
 - c) Try Square
 - d) Divider



BHARTIYA SKILL DEVELOPMENT UNIVERSITY

5. Punching is a process of-
 - a) Making conical depression on to the surface of the workpiece
 - b) Transferring the dimension and contour onto the workpiece surface
 - c) Both a & b
 - d) None of them
6. The size of the rake angle mainly influences-
 - a) Workpiece surface
 - b) Friction between tool and workpiece
 - c) Chip formation and cutting force
 - d) None of the above
7. Which of the following is not responsible for the penetration of cutting wedge into the workpiece?
 - a) Relief angle
 - b) Wedge angle
 - c) Workpiece material
 - d) Cutting force
8. What happens if the size of the clearance angle/relief angle becomes very less?
 - a) The friction will be more and the surface quality will be bad
 - b) Chips will break very easily
 - c) The tool will penetrate deeper
 - d) None of the above
9. Which chisel is used in making lubricating grooves?
 - a) flat chisel
 - b) Web chisel
 - c) Cape chisel
 - d) Round nose chisel
10. What is the application of the anvil plate?
 - a) To support the workpiece for scribing
 - b) To use as a base plate
 - c) To measure the angle
 - d) None of the above

Section – B

04X04 = 16 Marks

11. Write the formula for cutting speed. Also, define its nomenclature with its units. If rpm is given 1000 and tool diameter is 1 cm, then calculate cutting speed.
12. What do you understand by Bench vice? Write the names of its parts. (with diagram)
13. Explain the cutting tool geometry. Also, highlight the negative and positive rake angle (with figures).
14. Write short notes on the following:
 - a) Scribing
 - b) Punching
 - c) Free cutting
 - d) File designation system



BHARTIYA SKILL DEVELOPMENT UNIVERSITY

Section – C

04X06 = 24 Marks

15. What occupational safety should be considered during the work in the workshop (any ten)?
16. a) Write the application of filing
b) Describe the difference between cut files and milled files (at least five)
17. Describe the geometry of the cut file and milled file with neat and clean diagram.
18. Describe the Rules and Techniques should be considered during the filing (minimum 300 words).

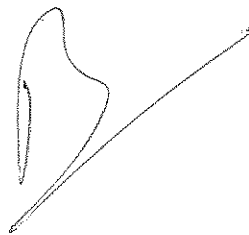

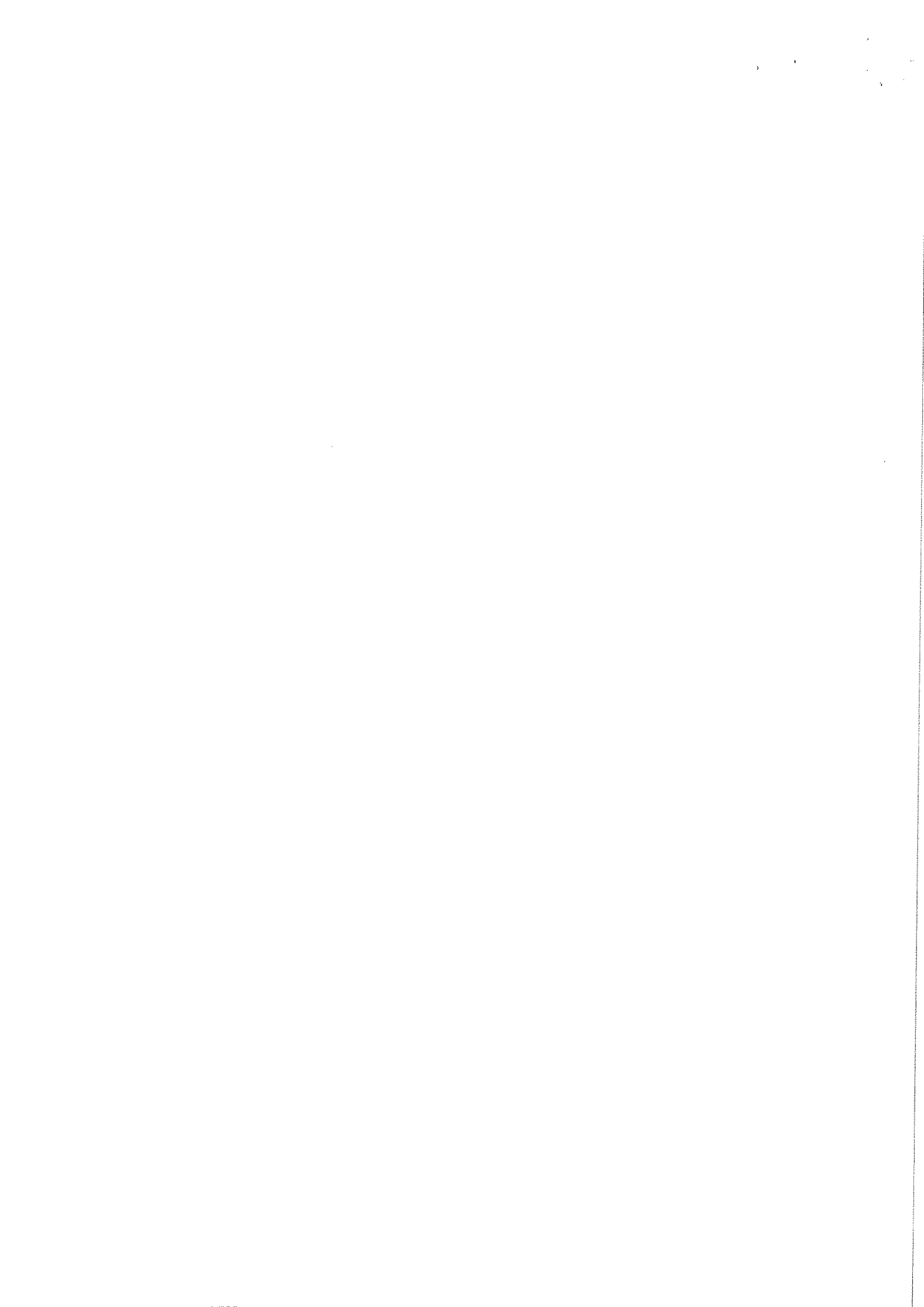



BHARTIYA SKILL DEVELOPMENT UNIVERSITY

Registration No.:

School of Manufacturing Skills
Session: 2020-21 (Summer Semester)
B. Voc. Program, I Semester,
End-Sem. Examination

Course Code: SMS1102
Course Name: Handskills

Time: 2 Hour
Max. Marks: 50

Answer Key

←—————→
Section – A

10X01 = 10 Marks

1. The drill which has taper shank should be clamped in-
 - a) **Sleeve**
 - b) Drill chuck
 - c) Tap wrench
 - d) Collect chuck
2. Which of the file cut configuration has the worst chip evacuation?
 - a) **Straight cut**
 - b) Curved cut
 - c) Diagonal
 - d) Both a & b
3. Counter boring can be done without pre-drill-
 - a) True
 - b) **False**
4. Which of the following tool is used to scribe the circle, radii and hole spacing when the dimensions are large?
 - a) Marking T-rule
 - b) **Trammel**
 - c) Try Square
 - d) Divider
5. Punching is a process of-
 - a) **Making conical depression on to the surface of the workpiece**
 - b) Transferring the dimension and contour onto the workpiece surface
 - c) Both a & b
 - d) None of them



BHARTIYA SKILL DEVELOPMENT UNIVERSITY

6. The size of the rake angle mainly influences-
- Workpiece surface
 - Friction between tool and workpiece
 - Chip formation and cutting force**
 - None of the above
7. Which of the following is not responsible for the penetration of cutting wedge into the workpiece?
- Relief angle**
 - Wedge angle
 - Workpiece material
 - Cutting force
8. What happens if the size of the clearance angle/relief angle becomes very less?
- The friction will be more and the surface quality will be bad**
 - Chips will break very easily
 - The tool will penetrate deeper
 - None of the above
9. Which chisel is used in making lubricating grooves?
- flat chisel
 - Web chisel
 - Cape chisel
 - Round nose chisel**
10. What is the application of the anvil plate?
- To support the workpiece for scribing
 - To use as a base plate**
 - To measure the angle
 - None of the above

Section – B

04X04 = 16 Marks

11. Write the formula for cutting speed. Also, define its nomenclature with its units. If rpm is given 1000 and tool diameter is 1 cm, then calculate cutting speed.

Answer:

Cutting speed is defined as the speed (usually in meter per minute) of a tool when it is cutting the workpiece.

$$\text{Formula: } V_c = \frac{\pi DN}{1000} \frac{m}{\text{minute}}$$

Where D: tool dia

N: RPM

Vc: Cutting speed

Put the values in the above expression we have

$$V_c = (3.14 \times 10 \times 1000) / 1000 = 31.4 \text{ m/min. (1cm=10 mm)}$$

12. What do you understand by Bench vice? Write the names of its parts. (with diagram)

Answer:

It is the most commonly used vice sometimes also known as parallel jaw vice. It essentially consists of a cast steel body, a movable jaw, a fixed jaw, both made of cast steel, a handle, a square threaded screw and a nut all made of mild steel. Separate cast steel plates known as jaw plates



BHARTIYA SKILL DEVELOPMENT UNIVERSITY

with teeth are fixed to the jaws using set screws and they can be replaced when worn. The movement of the vice is caused by the screw which passes through the nut fixed under the movable jaw.

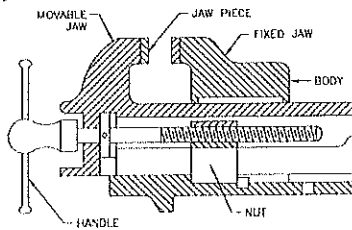

13. Explain the cutting tool geometry. Also, highlight the negative and positive rake angle (with figures).

Answer:

There are three cutting angles of the cutting edge

1. Wedge angle
2. Rake angle
3. Relief angle.

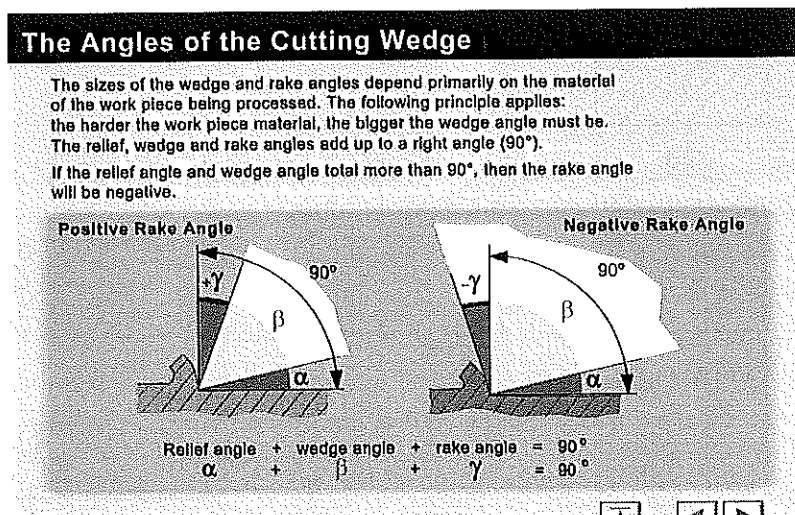
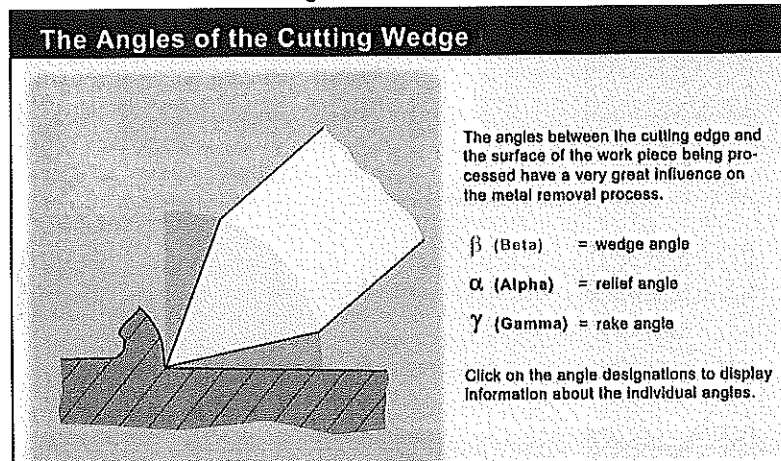

14. Write short notes on the following:

- a) Scribing b) Punching c) Free cutting d) File designation system

Answer:

- a) Scribing: It is a process to transfer the drawing dimensions and contours onto the workpiece.
 b) Punching: It is a process to make a conical depression onto the workpiece surface.
 c) Free Cutting: The cutting without interruptions is known as free-cutting in sawing.
 d) File designation:

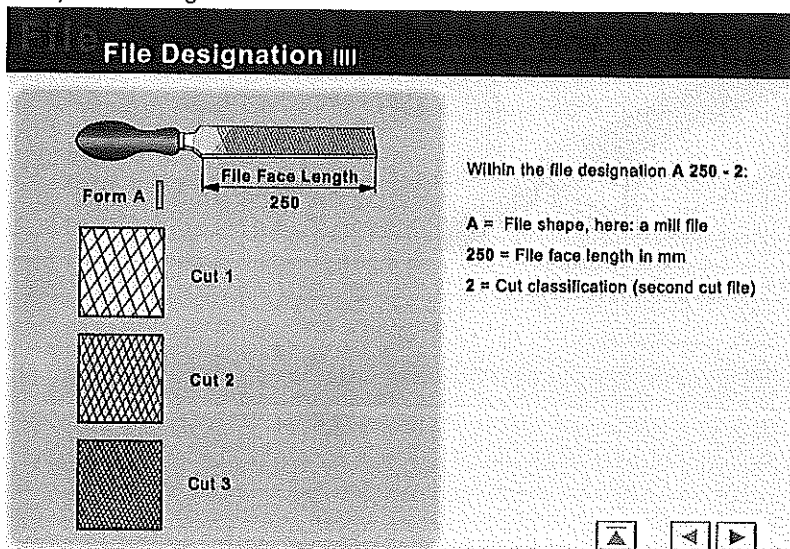

Section – C

04X06 = 24 Marks

15. What occupational safety should be considered during the work in the workshop (any ten)?

Answer:

- Clamp the workpiece firmly in the vice
- Prevent the saw from the slipping off by filing a notch
- Reduce the pressure before separating the workpiece
- Deburr the workpiece after sawing
- Check for a solid seating of the filehandle
- The damaged file handle is to be replaced immediately
- Wear the safety shoes during the filling
- Use safety glasses for eye protection.
- Don't wear jewellery.
- Don't remove the chips with your finger, use the brush to remove chips.
- Deburr the workpiece on all sides.

16. a) Write the application of filing

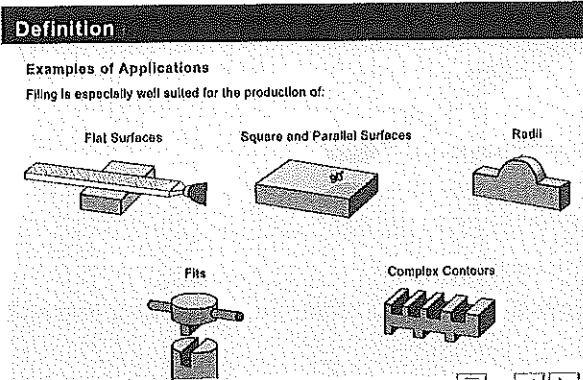

b) Describe the difference between cut files and milled files (at least five)

S.N	Cut files(Hewn)	Milled files
1	Cut files are made by the chiselling notches into the file face.	Milled file are made by Milling into the file face.
2	These files have the negative rake angle and a scrapping effect.	These files have positive rake angle
3	The large wedge angle makes for a stable cutting edge.	They cut better than the cut files
4	Cut files are prepared for the hard material. Such as cast iron, steel etc.	Suitable for the soft material such as aluminium ,copper and plastic
5	In the cut files the chip evacuation is worse than milled file	Better chip evacuation compares to cut files.

17. Describe the geometry of the cut file and milled file with neat and clean diagram.

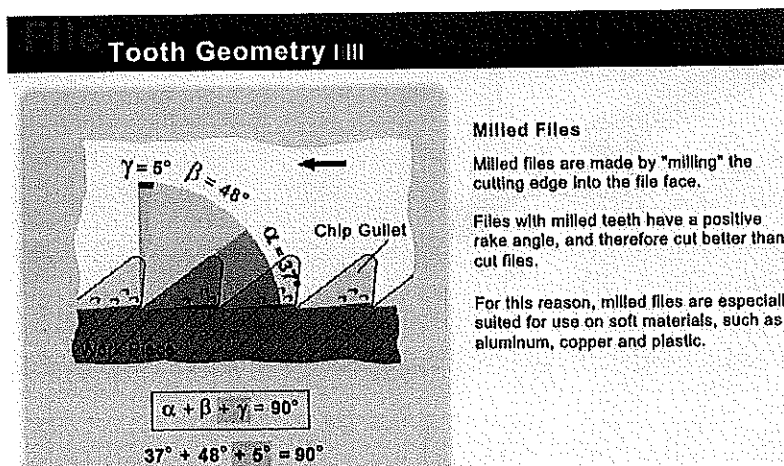
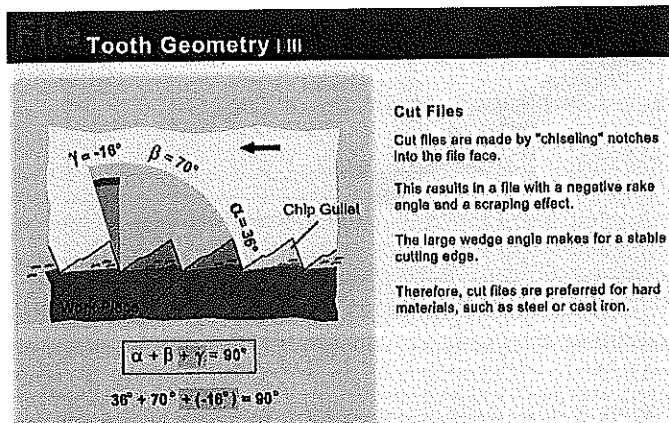



BHARTIYA SKILL DEVELOPMENT UNIVERSITY

18. Describe the Rules and Techniques should be considered during the filing (minimum 300 words).

Answer:

The Rules and Techniques Should Be Considered During the Filing

- Clamp the workpiece properly, 70% part should be covered in clamping (as per workpiece clamping rules)
- Hold the file as per instructions
- Take the proper posture and gesture (running position).
- The distance between the feet and the hands should be equal.
- Start filing diagonally at 20 degrees.
- Correct force distribution and movement direction
- The file only removes material in the forward direction so exert pressure only in the cutting direction
- Inspect the workpiece as per need.
- To inspect the flatness of the surface, the knife-edge ruler is used. The method used for it is known as Light gap method.
- To check the 90 degrees of two surface, the try square is used.

The Rules and Techniques Should Be Considered During the Filing

- Scribing should be accurate (with an allowance of 1-2 mm for finishing) and visible
- The workpiece should be tightly clamped
- Saw blade clamping (teeth should be in the forward direction).
- Check saw blade tension. it must be tight and having proper TPI.
- Posture and gesture should be proper.
- Make a notch by triangular file to guide the saw blade.
- Start sawing slowly with light pressure at an angle of approx. 15 degrees.
- Slowly-2 increase the pressure and reduce the angle, make the saw straight.
- Consistent pressure is applied to the saw on the forward stroke
- On the return stroke, the pressure is taken off so that the teeth don't become dull.
- Use the entire length of the saw blade results most effective and efficient sawing.
- Continue the cutting...by observing the scribing line.



BHARTIYA SKILL DEVELOPMENT UNIVERSITY

Registration No.:

Set B

School of Manufacturing Skills
Session: 2020-21 (Summer Semester)
B. Voc. Program, I Semester,
End-Sem. Examination

Course Code: SMS1102
Course Name: Handskills

Time: 2 Hour
Max. Marks: 50

Instructions:

1. Attempt all questions.
2. Section A contains 10 Questions. Each question carries 1 Mark.
3. Section B contains 04 Questions. Each question carries 4 Marks.
4. Section C contains 04 Questions. Each question carries 6 Marks.

Section – A

10X01 = 10 Marks

1. Which is not a type of tool holder?
 - a) Sleeve
 - b) Drill chuck
 - c) Tap wrench
 - d) Tap
2. Which of the file cut configuration has the worst chip evacuation?
 - a) Straight cut
 - b) Curved cut
 - c) Diagonal
 - d) Both a & b
3. Reaming can be done without pre-drill -
 - a) True
 - b) False
4. Which of the following tool is used to scribe the circle, radii and hole spacing when the dimensions are small?
 - a) Marking T-rule
 - b) Trammel
 - c) Try Square
 - d) Divider



BHARTIYA SKILL DEVELOPMENT UNIVERSITY

5. Scribing is a process of-
 - a) Making conical depression on to the surface of the workpiece
 - b) Transferring the dimension and contour onto the workpiece surface
 - c) Both a & b
 - d) None of them
6. The size of the clearance angle mainly influences-
 - a) Workpiece surface
 - b) Friction between tool and workpiece
 - c) Chip formation and cutting force
 - d) None of the above
7. Which of the following is responsible for the penetration of cutting wedge into the workpiece?
 - a) Relief angle
 - b) Wedge angle
 - c) Relief angle
 - d) None
8. Negative rake angle is used for-
 - a) Hard material
 - b) Soft material
 - c) Very soft material
 - d) None
9. Which chisel is used to remove weld seams?
 - a) Flat chisel
 - b) Web chisel
 - c) Cape chisel
 - d) Round nose chisel
10. What is the application of the anvil plate?
 - a) To support the workpiece for scribing
 - b) To use as a base plate
 - c) To measure the angle
 - d) None of the above

Section – B

04X04 = 16 Marks

11. Write the formula for cutting speed. Also, define its nomenclature with its units. If rpm is given 100 and tool diameter is 10 cm, then calculate the cutting speed.
12. A) Write the formula for the following (with Diagram)
 - a. Depth for blind drill
 - b. Depth of throughout tap
 - c. Depth for blind tapB) Explain the reaming and counter boring process and write the formula for cutting speed for the same processes and also write the value of cutting speed when the work is to be done on mild steel by using high-speed steel tool.
13. Explain the cutting tool geometry. Also, highlight the negative and positive rake angle (with figures).
14. Write short notes on the following:
 - a) Scribing
 - b) Punching
 - c) Free cutting
 - d) File designation system



BHARTIYA SKILL DEVELOPMENT UNIVERSITY

Section – C

04X06 = 24 Marks

15. Derive the expression for the chamfer value to make radius by using filing with diagram.
16. a) Write the application of filing (at least five)

b) Describe the geometry of the cut file and milled file with neat and clean diagram.
17. Describe the Rules and Techniques should be considered during the filing (minimum 300 words).
18. Write any five scribing tools and accessories with their application.





BHARTIYA SKILL DEVELOPMENT UNIVERSITY

Registration No.:

School of Manufacturing Skills
Session: 2020-21 (Summer Semester)
B. Voc. Program, I Semester,
End-Sem. Examination

Course Code: SMS1102
Course Name: Handskills

Time: 2 Hour
Max. Marks: 50

Answer Key

Section – A

10X01 = 10 Marks

1. Which is not a type of tool holder?
 - a) Sleeve
 - b) Drill chuck
 - c) Tap wrench
 - d) **Tap**
2. Which of the file cut configuration has the worst chip evacuation?
 - a) **Straight cut**
 - b) Curved cut
 - c) Diagonal
 - d) Both a & b
3. Reaming can be done without pre-drill -
 - a) True
 - b) **False**
4. Which of the following tool is used to scribe the circle, radii and hole spacing when the dimensions are small?
 - a) Marking T-rule
 - b) Trammel
 - c) Try Square
 - d) **Divider**
5. Scribing is a process of-
 - a) Making conical depression on to the surface of the workpiece
 - b) **Transferring the dimension and contour onto the workpiece surface**
 - c) Both a & b
 - d) None of them
6. The size of the clearance angle mainly influences-
 - a) Workpiece surface
 - b) **Friction between tool and workpiece**
 - c) Chip formation and cutting force



BHARTIYA SKILL DEVELOPMENT UNIVERSITY

- d) None of the above
7. Which of the following is responsible for the penetration of cutting wedge into the workpiece?
- Relief angle
 - Wedge angle**
 - Relief angle
 - None
8. Negative rake angle is used for-
- Hard material**
 - Soft material
 - Very soft material
 - None
9. Which chisel is used to remove weld seams?
- Flat chisel**
 - Web chisel
 - Cape chisel
 - Round nose chisel
10. What is the application of the anvil plate?
- To support the workpiece for scribing
 - To use as a base plate**
 - To measure the angle
 - None of the above

Section – B

04X04 = 16 Marks

11. Write the formula for cutting speed. Also, define its nomenclature with its units. If rpm is given 100 and tool diameter is 10 cm, then calculate the cutting speed.

Cutting speed is defined as the speed (usually in meter per minute) of a tool when it is cutting the workpiece.

$$\text{Formula: } V_c = \frac{\pi DN}{1000} \frac{m}{\text{minute}}$$

Where D: tool dia

N: RPM

Vc: Cutting speed

Put the values in the above expression we have

$$V_c = (3.14 \times 100 \times 100) / 1000 = 31.4 \text{ m/min. (1cm=10 mm)}$$

12. A) Write the formula for the following (with Diagram)
- Depth for blind drill
 - Depth of throughout tap
 - Depth for blind tap

Answer:

For Blind Drill

$$\text{Depth} = H + 0.3D$$

Where

H= given drawing depth

D= drill diameter

For throughout tap

$$\text{Depth} = H + 0.7D + 0.3D + 3$$

Where

H= given drawing depth

D= drill diameter

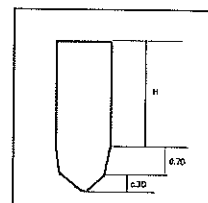
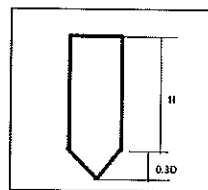

3 = it indicates the machine default value

For Blind tap:

$$\text{Depth} = H + 0.5D + 3$$

Where

H = given draw. Depth

D = drill diameter

3 = it indicates the machine default value

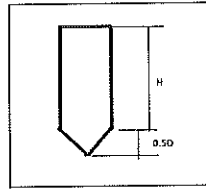

B) Explain the reaming and counter boring process and write the formula for cutting speed for the same processes and also write the value of cutting speed when the work is to be done on mild steel by using high speed steel tool.

Answer:

Reaming: It is a process to enlarge a hole with high accuracy and surface finishing. The tools used for it, is known as reamer.

$$\text{The cutting speed } v_c = \frac{1}{3} \left(\frac{\pi DN}{1000} \right) \frac{m}{min}$$

At given condition Vc is 8 m/min.

Counter boring: It is a process to enlarge a hole with a certain depth. CB is generally used for the counter bore head screw to compensate the width of the head of the screw.

$$\text{The cutting speed } v_c = \frac{2}{3} \left(\frac{\pi DN}{1000} \right) \frac{m}{min}$$

At given condition Vc is 17 m/min.

13. Explain the cutting tool geometry. Also, highlight the negative and positive rake angle (with figures).

The Angles of the Cutting Wedge

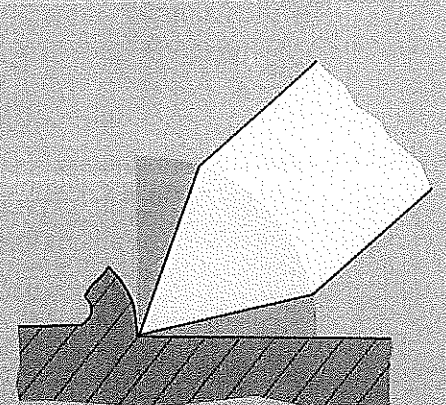

The angles between the cutting edge and the surface of the work piece being processed have a very great influence on the metal removal process.

β (Beta) = wedge angle

α (Alpha) = relief angle

γ (Gamma) = rake angle

Click on the angle designations to display information about the individual angles.

The Angles of the Cutting Wedge

The sizes of the wedge and rake angles depend primarily on the material of the work piece being processed. The following principle applies: the harder the work piece material, the bigger the wedge angle must be. The relief, wedge and rake angles add up to a right angle (90°). If the relief angle and wedge angle total more than 90°, then the rake angle will be negative.

Positive Rake Angle

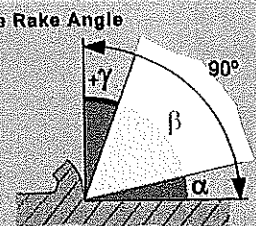

Negative Rake Angle

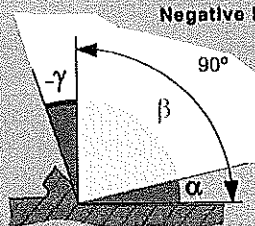

$$\begin{matrix} \text{Relief angle} & + & \text{wedge angle} & + & \text{rake angle} & = & 90^\circ \\ \alpha & + & \beta & + & \gamma & = & 90^\circ \end{matrix}$$

14. Write short notes on the following:

- a) Scribing b) Punching c) Free cutting d) File designation system

Answer:

- a) Scribing: It is a process to transfer the drawing dimensions and contours onto the workpiece.
 b) Punching: It is process to make a conical depression onto the workpiece surface.
 c) Free Cutting: The cutting without interruptions is known as free cutting in sawing.
 d) File designation:

File Designation IIII

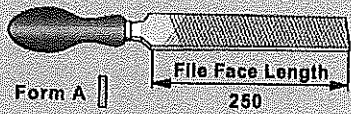

Cut 1

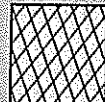

Cut 2

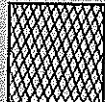

Cut 3

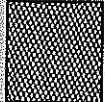

Within the file designation A 250 - 2:

A = File shape, here: a mill file
250 = File face length in mm
2 = Cut classification (second cut file)



Section – C

04X06 = 24 Marks

15. Derive the expression for the chamfer value to make radius by using filing with diagram.

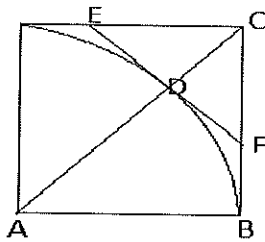

In triangle ABC –

$$AB^2 + BC^2 = AC^2$$

$$AC = \sqrt{AB^2 + BC^2} = \sqrt{R^2 + R^2} = \sqrt{2R^2} = R\sqrt{2} = 1.414R$$

$$\text{Since, } AC = AD + DC ; \quad DC = AC - AD = 1.414R - R = 0.414R$$

In triangle CDF –

Since DC and DF are equal,

$$\text{Hence, } CF^2 = DC^2 + DF^2 = 0.414R^2 + 0.414R^2$$

$$CF = \sqrt{(0.414R^2 + 0.414R^2)} = 0.414R\sqrt{2} = 0.414R \times 1.414$$

$$\mathbf{CF = 0.58R}$$

16. a) Write the application of filing (at least five)

Definition

Examples of Applications

Filing is especially well suited for the production of:

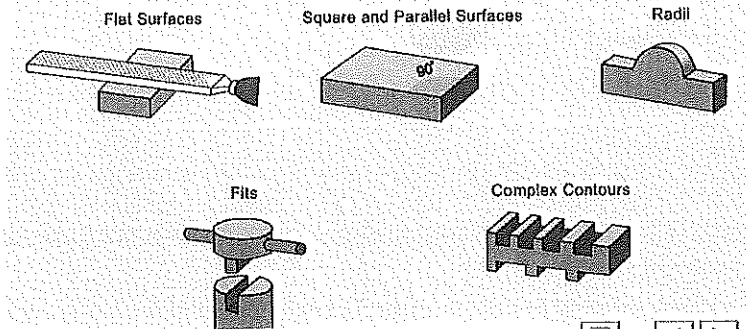

b) Describe the geometry of the cut file and milled file with neat and clean diagram.

Tooth Geometry | III

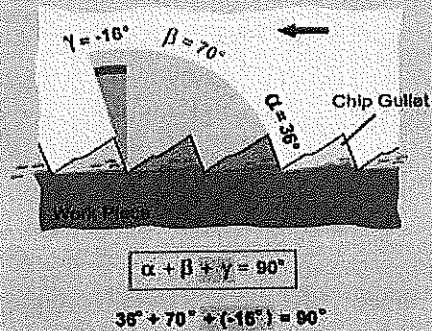

Cut Files

Cut files are made by "chiselling" notches into the file face.

This results in a file with a negative rake angle and a scraping effect.

The large wedge angle makes for a stable cutting edge.

Therefore, cut files are preferred for hard materials, such as steel or cast iron.

Tooth Geometry | III

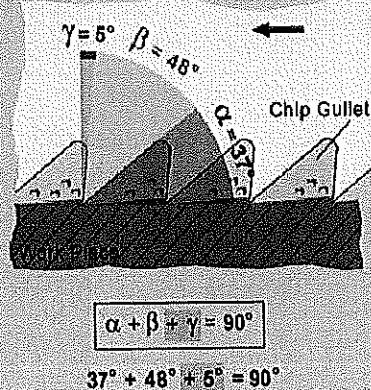

Milled Files

Milled files are made by "milling" the cutting edge into the file face.

Files with milled teeth have a positive rake angle, and therefore cut better than cut files.

For this reason, milled files are especially suited for use on soft materials, such as aluminum, copper and plastic.



BHARTIYA SKILL DEVELOPMENT UNIVERSITY

17. Describe the Rules and Techniques should be considered during the filing (minimum 300 words).

Answer:

The Rules and Techniques Should Be Considered During the Filing

- Clamp the workpiece properly, 70% part should be covered in clamping (as per workpiece clamping rules)
- Hold the file as per instructions
- Take the proper posture and gesture (running position).
- The distance between the feet and the hands should be equal.

- Start filing diagonally at 20 degrees.
- Correct force distribution and movement direction
- The file only removes material in forward direction so exert pressure only in the cutting direction
- Inspect the workpiece as per need.
- To inspect the flatness of surface, knife edge ruler is used. The method used for it is known as Light gap method.
- To check the 90 degree of two surface, the try square is used.

The Rules and Techniques Should Be Considered During the Filing

- Scribing should be accurate (with an allowance of 1-2 mm for finishing) and visible
- Workpiece should be tightly clamped
- Saw blade clamping (teeth should be in forward direction).
- Check saw blade tension .it must be tight and having proper TPI.
- Posture and gesture should be proper.
- Make a notch by triangular file to guide the saw blade.
- Start sawing slowly with a light pressure at an angle of approx. 15 degrees.
- Slowly-2 increase the pressure and reduce the angle, make the saw straight.
- Consistent pressure is applied to the saw on the forward stroke
- On the return stroke, the pressure is taken off so that the teeth don't become dull.
- Use the entire length of the saw blade results most effective and efficient sawing.
- Continue the cutting....by observing the scribing line.

18. Write any five scribing tools and accessories with their application.

Answer:

1. Scribing tool (brass)
2. Trammel
3. Marking t rule
4. Centre head
5. Divider



BHARTIYA SKILL DEVELOPMENT UNIVERSITY

Registration No.:

Sel - A

School of Manufacturing Skills Session: 2020-21 (Summer Semester) B. Voc. Program, I Semester, End-Sem. Examination

Course Code: SMS1103
Course Name: Conventional Milling

Time: 2 Hour
Max. Marks: 50

Instructions:

1. Attempt all questions.
2. Section A contains 10 Questions. Each question carries 1 Mark.
3. Section B contains 04 Questions. Each question carries 4 Marks.
4. Section C contains 04 Questions. Each question carries 6 Marks.

Section – A

10X01 = 10 Marks

1. What is the Normal Clearance angle in Tool?
 - a) 8 -10°
 - b) 6-8°
 - c) 4-6
 - d) 5-7°
2. Wedge angle is the angle between _____ and _____.
 - a) Tool flank & face
 - b) Face & finish surface
 - c) The perpendicular line to the point of contact & rake face
 - d) None of these
3. What is the range for Vc on Mild Steel Workpiece with hss tool?
 - a) 100-400
 - b) 50-100
 - c) 25-30
 - d) 50-75
4. Type 'H' milling cutters are used to cut _____ materials.
 - a) Soft & stringy
 - b) Hard & tough
 - c) Hardened steel
 - d) All of the above



BHARTIYA SKILL DEVELOPMENT UNIVERSITY

5. Which type of wear is caused due to fluctuations in temperature?
 - a) Edge fractures
 - b) Thermal cracks
 - c) Edge build-up
 - d) Chips & splinters
6. Which tool holder is used for clamping Morse taper tool?
 - a) Collet type tool holder
 - b) Reducing bushes
 - c) Weldon type tool holder
 - d) Arbor type tool holder
7. What is the coolant concentration range for milling?
 - a) 6-8%
 - b) 12-15%
 - c) 5-7%
 - d) 18-20%
8. What is another name of down milling?
 - a) Climb milling
 - b) Conv milling
 - c) Up milling
 - d) None of these
9. Which tool holder is used to clamping edge finder?
 - a) Weldon type
 - b) Collet type
 - c) Weldon type
 - d) Reducing bush type
10. Which tool is used to make a chamfer on the workpiece?
 - a) Shoulder mill
 - b) Face mill
 - c) Slot drill
 - d) End mill

Section – B

04X04 = 16 Marks

11. Write any 4 uses of Cutting Oil.
12. What is Milling and differentiate between grinding and milling?
13. Write the difference between turning and milling.
14. Write the uses of different types of milling tool holders.



BHARTIYA SKILL DEVELOPMENT UNIVERSITY

Section – C

04X06 = 24 Marks

15. Explain any four types of Milling processes.
16. Describe the Steps to calculate R.P.M for $\varnothing 50$ Face mill with $V_c = 450$ and also calculate its Feed Rate with feed per tooth 0.15.?
17. Explain the following: -
 - a. Plano milling machine
 - b. CNC milling machine.
18. Differentiate up milling and down milling with a suitable diagram.

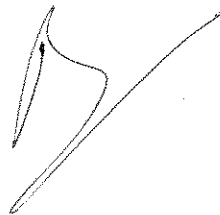





BHARTIYA SKILL DEVELOPMENT UNIVERSITY

Registration No.:

School of Manufacturing Skills
Session: 2020-21 (Summer Semester)
B. Voc. Program, I Semester,
End-Sem. Examination

Course Code: SMS1103

Time: 2 Hour

Course Name: Conventional Milling

Max. Marks: 50

Answer Key

Section – A

10X01 = 10 Marks

1. What is the Normal Clearance angle in Tool?
 - a) 8-10°
 - b) **6-8°**
 - c) 4-6
 - d) 5-7°
2. Wedge angle is the angle between _____ and _____.
 - a) **Tool flank & face**
 - b) Face & finish surface
 - c) The perpendicular line to the point of contact & rake face
 - d) None of these
3. What is the range for Vc on Mild Steel Workpiece with hss tool?
 - a) 100-400
 - b) 50-100
 - c) **25-30**
 - d) 50-75
4. Type 'H' milling cutters are used to cut _____ materials.
 - a) Soft & stringy
 - b) **Hard & tough**
 - c) Hardened steel
 - d) All of the above
5. Which type of wear is caused due to fluctuations in temperature?
 - a) Edge fractures
 - b) **Thermal cracks**
 - c) Edge build-up
 - d) Chips & splinters



BHARTIYA SKILL DEVELOPMENT UNIVERSITY

6. Which tool holder is used for clamping Morse taper tool?
 - a) Collet type tool holder
 - b) Reducing bushes**
 - c) Weldon type tool holder
 - d) Arbor type tool holder
7. What is the coolant concentration range for milling?
 - a) 6-8%**
 - b) 12-15%
 - c) 5-7%
 - d) 18-20%
8. What is another name of down milling?
 - a) Climb milling**
 - b) Conv milling
 - c) Up milling
 - d) None of these
9. Which tool holder is used to clamping edge finder?
 - a) Weldon type
 - b) Collet type**
 - c) Weldon type
 - d) Reducing bush type
10. Which tool is used to make a chamfer on the workpiece?
 - a) Shoulder mill
 - b) Face mill**
 - c) Slot drill
 - d) End mill

Section – B

04X04 = 16 Marks

11. Write any 4 uses of Cutting Oil.

Ans-

1. It helps to improve surface quality
2. It prevents the tool from wear
3. It maintain the temperature while working on machines
4. It helps to increase tool life

12. What is Milling and differentiate between grinding and milling?

Ans-

Milling is a metal removing process in which we use a multi point cutting tool. In milling our workpiece is stationary and the tool is rotating. In grinding, we use the geometrically defined cutting tool.



BHARTIYA SKILL DEVELOPMENT UNIVERSITY

Milling	Grinding
In milling, we use the geometrically defined cutting tool.	In grinding we use undefined geometry cutting tool.
In milling, we use multi-point cutting tool.	In grinding, we use tool made from abrasive particles.

13. Write the difference between turning and milling.

Turning	Milling
In turning we use a single-point cutting tool	In milling we use multi-point cutting tool
In turning our tool is stationary and tool is rotating	In milling our tool is rotating and workpiece is stationary

14. Write the uses of different types of milling tool holders.

- Arbor type-This type of tool holder is used to clamp tool which doesn't have a shank.
- Collet type-This type of tool holder is used to clamp finishing tool or precise operation tools
- Weldone type-This types of the tool holder are used to clamp roughing tools
- Reducing buses-This type of tool holder is used to clamp tools having taper shank

Section – C

04X06 = 24 Marks

15. Explain any four types of Milling processes.

Face milling – When the material is removed from workpiece face and a new flat face is generated

Profile milling- Different type of profile tool is used to generate the same profile on the work piece

End peripheral milling- When the material is removed by end cutting edges and side cutting edges at the same time

Peripheral milling- When the material is removed by side or peripheral cutting edges

16. Describe the Steps to calculate R.P.M for $\varnothing 50$ Face mill with $V_c = 450$ and also calculate its Feed Rate with feed per tooth 0.15.?

$$V_c = 3.14 \times D \times N / 1000$$

$$N = V_c \times 1000 / 3.14 \times D$$

$$N = 450 \times 1000 / 3.14 \times 50$$

$$N = 2866$$

$$F_z = \text{feed per tooth} \times \text{rpm}$$

$$F_z = 0.15 \times 2866$$

$$F_z = 429$$

17. Explain the following: -

a. Plano milling machine

► **Plano-milling machine**

Plano-milling machines do not have a vertically adjustable table. The milling table only moves along the longitudinal axis. The milling head is used for cross feed and height adjustment. Thus, plano-milling machines are highly suited for large, long, high and heavy workpieces.

b. CNC milling machine.

► **CNC milling machines**

CNC milling machines (CNC = Computerized Numerical Control) typically have a "three-axis-continuous-path-control."

Each axis is driven by its own feed drive through a direct-sensing measuring path system. The axes have backlash-free ball-type linear drives. The automated tool exchange requires a quick-release clamping fixture for steep-angle taper tools or hollow-shank taper tools with electro-hydraulic control. Depending on the design of the CNC milling machine, the tools can be stored in turret, cluster, drum or chain magazines and positioned according to the process sequence.

18. Differentiate up milling and down milling with a suitable diagram.

► **Conventional milling**

In this process, the feed motion runs contrary to the cutting motion of the milling cutter. The cutting edges slide over the workpiece surface and cut into the material at the interface with high pressure. The resulting friction causes increased wear on the tool flanks. As the material is cut, a force (F_1) is exerted on the workpiece. Because the cutting force (F_2) works against the workpiece, a force (F_3) develops which attempts to loosen the workpiece from the clamping equipment. Faulty clamping may cause diminished surface quality and even force the workpiece out of the clamping equipment. Due to the opposing forces, some play in the feed device has a positive affect. Conventional milling can be performed on all milling machines.

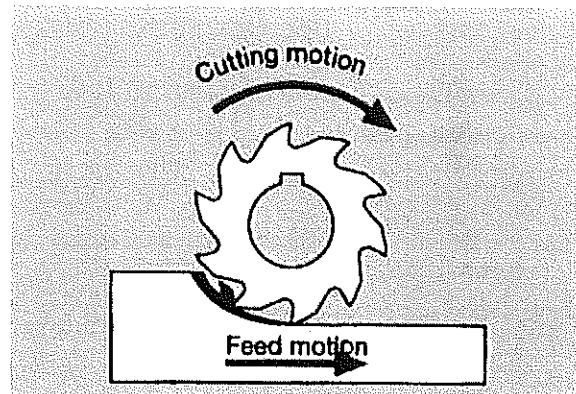

► Down milling

In this process, the workpiece feed motion operates in the same direction as the cutting motion of the milling cutter. The cutting edges cut abruptly into the surface of the workpiece and make the largest cut right at the beginning. As the material is cut, a force (F_1) is exerted on the workpiece. The cutting force (F_2) works in the direction of the feed motion. The resulting force (F_r) attempts to pull the workpiece under the milling cutter. In order to oppose this, the milling machine's feed drive must function backlash-free; it must be capable of controlling the forces that develop. Down milling enables larger cutting depths compared to conventional milling; therefore, it can only be performed on especially stable milling machines.

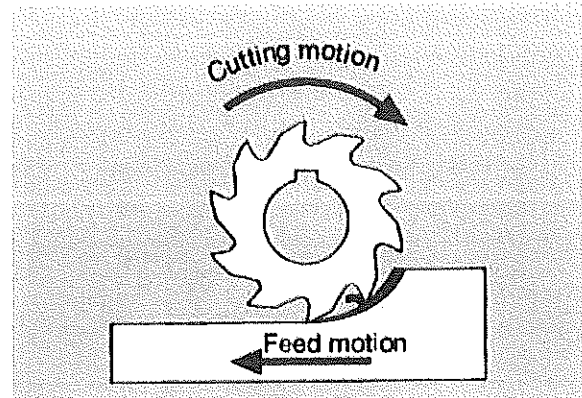





BHARTIYA SKILL DEVELOPMENT UNIVERSITY

Registration No.:

~~Set-A~~ Set-B

School of Manufacturing Skills
Session: 2020-21 (Summer Semester)
B. Voc. Program, I Semester,
End-Sem. Examination

Course Code: SMS1103

Course Name: Conventional Milling

Time: 2 Hour

Max. Marks: 50

Instructions:

1. Attempt all questions.
2. Section A contains 10 Questions. Each question carries 1 Mark.
3. Section B contains 04 Questions. Each question carries 4 Marks.
4. Section C contains 04 Questions. Each question carries 6 Marks.

Section – A

10X01 = 10 Marks

1. Which tool is used to make a chamfer on the workpiece?
 - a) Shoulder mill
 - b) Face mill
 - c) Slot drill
 - d) End mill
2. What is the Normal Clearance angle in Tool?
 - a) 8 -10°
 - b) 6-8°
 - c) 4-6
 - d) 5-7°
3. Clearance angle is the angle between _____ and _____.
 - a) Tool flank & face
 - b) Face & finish surface
 - c) The perpendicular line to the point of contact & rake face
 - d) None of these
4. What is the range for Vc on Mild Steel Workpiece with carbide tool?
 - a) 75-100
 - b) 50-75
 - c) 25-30
 - d) 0-25



BHARTIYA SKILL DEVELOPMENT UNIVERSITY

5. Type 'H' milling cutters are used to cut _____ materials.
 - a) Soft & stringy
 - b) Hard & tough
 - c) Hardened steel
 - d) All of the above
6. Which type of wear is caused due to friction between tool and workpiece?
 - a) Edge fractures
 - b) Thermal cracks
 - c) Edge build-up
 - d) Flank wear
7. Which tool holder is used for clamping Morse taper tool?
 - a) Collet type tool holder
 - b) Reducing bushes
 - c) Weldon type tool holder
 - d) Arbor type tool holder
8. Which tool is used to make a slot on the workpiece?
 - a) Shell end mill
 - b) shoulder mill
 - c) face mill
 - d) slot drill
9. What is another name of down milling?
 - a) Climb milling
 - b) Conv milling
 - c) Up milling
 - d) None of these
10. Which tool holder is used to clamp edge finder?
 - a) Weldon type
 - b) collet type
 - c) Arbor type
 - d) Reducing bush type

Section – B

04X04 = 16 Marks

11. Write any 4 safety precautions while working on the machine.
12. Write a short note on thermal cracks and built-up edge tool wear.
13. Write the difference between shoulder mill and face mill cutter.
14. Write the difference between slot drill and end mill cutter.



BHARTIYA SKILL DEVELOPMENT UNIVERSITY

Section – C

04X06 = 24 Marks

15. Explain any four types of Milling processes.
16. Describe the Steps to calculate R.P.M for $\varnothing 22$ slot drill with $V_c = 100$ and also calculate its Feed Rate with feed per tooth 0.15.?
17. Explain the following: -
 - a. Horizontal milling machine
 - b. Vertical milling machine.
18. Differentiate up milling and down milling with a suitable diagram?

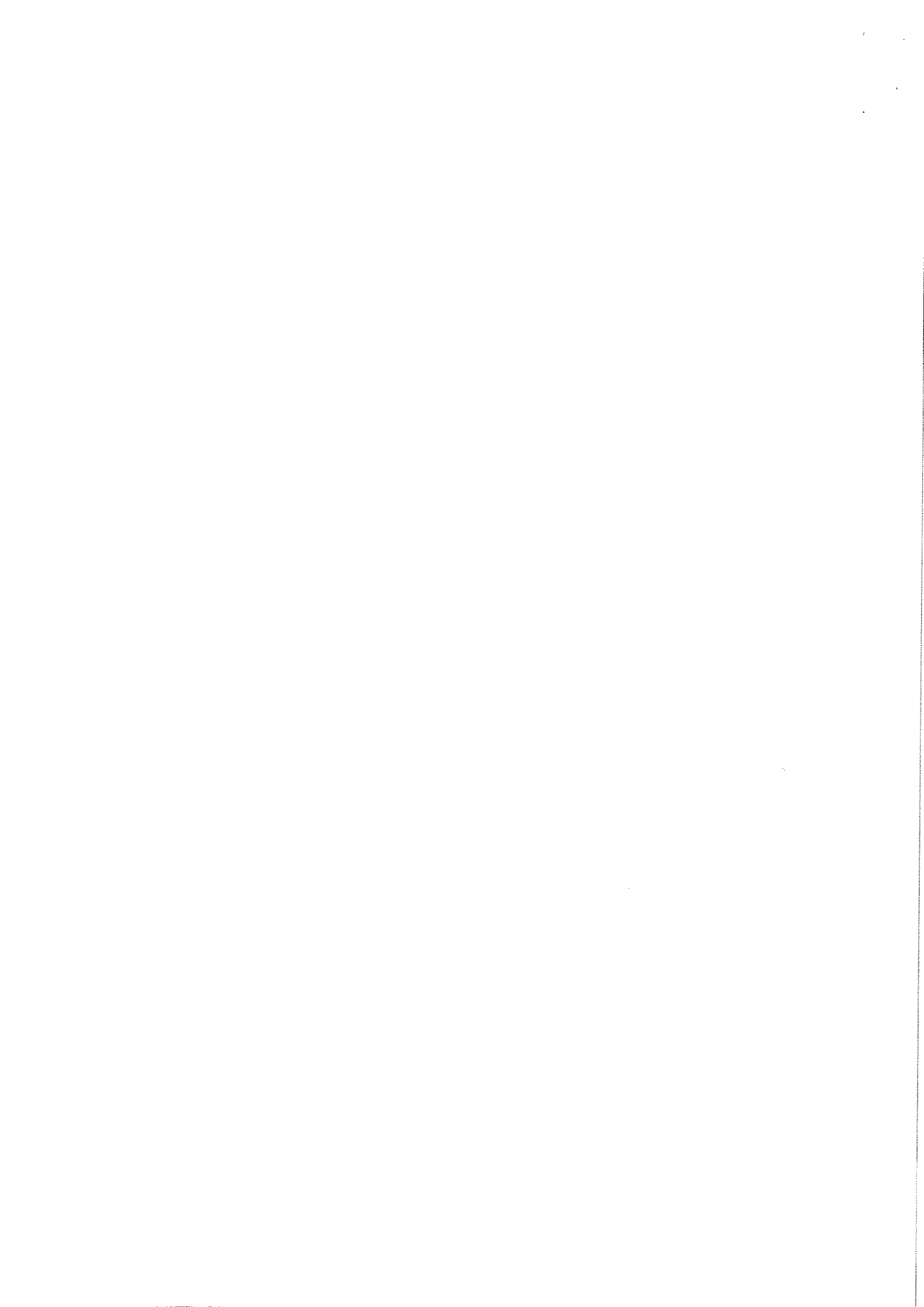



BHARTIYA SKILL DEVELOPMENT UNIVERSITY

Registration No.:

School of Manufacturing Skills
Session: 2020-21 (Summer Semester)
B. Voc. Program, I Semester,
End-Sem. Examination

Course Code: SMS1103

Course Name: Conventional Milling

Time: 2 Hour

Max. Marks: 50

Answer Key

Section – A

10X01 = 10 Marks

1. Which tool is used to make a chamfer on the workpiece?
 - a) Shoulder mill
 - b) Face mill**
 - c) Slot drill
 - d) End mill
2. What is the Normal Clearance angle in Tool?
 - a) 8 -10°**
 - b) 6-8°
 - c) 4-6
 - d) 5-7°
3. Clearance angle is the angle between _____ and _____.
 - a) Tool flank & face
 - b) Face & finish surface**
 - c) The perpendicular line to the point of contact & rake face
 - d) None of these
4. What is the range for Vc on Mild Steel Workpiece with carbide tool?
 - a) 75-100**
 - b) 50-75
 - c) 25-30
 - d) 0-25
5. Type 'H' milling cutters are used to cut _____ materials.
 - a) Soft & stringy
 - b) Hard & tough**
 - c) Hardened steel
 - d) All of the above
6. Which type of wear is caused due to friction between tool and workpiece?
 - a) Edge fractures
 - b) Thermal cracks**



BHARTIYA SKILL DEVELOPMENT UNIVERSITY

- c) Edge build-up
 - d) Flank wear
7. Which tool holder is used for clamping Morse taper tool?
- a) Collet type tool holder
 - b) Reducing bushes
 - c) Weldon type tool holder
 - d) Arbor type tool holder
8. Which tool is used to make a slot on the workpiece?
- a) Shell end mill
 - b) shoulder mill
 - c) face mill
 - d) slot drill
9. What is another name of down milling?
- a) Climb milling
 - b) Conv milling
 - c) Up milling
 - d) None of these
10. Which tool holder is used to clamp edge finder?
- a) Weldon type
 - b) collet type
 - c) Arbor type
 - d) Reducing bush type

Section – B

04X04 = 16 Marks

11. Write any 4 safety precautions while working on the machine.

ANS-

1. Always wear safety glass while working on machines
2. Always wear safety shoes while working on the shop floor
3. Don't wear bracelet watch or any ornaments on your hand
4. Don't wear loose clothes while working on the machine as they will be stuck on the machine at any time.

12. Write a short note on thermal cracks and built-up edge tool wear.

Thermal cracks

The expansion and contraction resulting from frequent changes in temperature cause the cutting material to fatigue and give rise to thermal cracks in the cutting edges.

Edge build-up forms on the cutting edge from the bonding of small pieces of material on the tool flank when the cutting speed is too low and the material is too strong. It forms in fractions of seconds, tears off when it reaches a certain size and then reforms on the cutting edge. This cycle repeats itself continuously during the removal process. Some fragments of the edge build-up may slide over the tool flank while others remain stuck to the workpiece surface like flakes. Over time, the cutting edges are damaged by the hard fragments from the edge build-up.



BHARTIYA SKILL DEVELOPMENT UNIVERSITY

13. Write the difference between shoulder mill and face mill cutter.

Face mill	Shoulder mill
Face mill cutter has inset at 45 angle A face mill is used to make 45 angle profile on workpiece like chamfer It is used for rough machining	Shoulder mill cutter has insert at 90 angle Shoulder mill is used to generate shoulder on the workpiece It is used for finishing

14. Write the difference between slot drill and end mill cutter.

Slot drill	End mill
Slot drill have centre cutting edges We can directly plunge into workpiece	End mill doesn't have centre cutting edges We can not direct plunge it into workpiece

Section – C

04X06 = 24 Marks

15. Explain any four types of Milling processes.

Face milling – When the material is removed from workpiece face and a new flat face is generated

Profile milling- Different type of profile tool is used to generate the same profile on the work piece

End peripheral milling- When the material is removed by end cutting edges and side cutting edges at the same time

Peripheral milling- When the material is removed by side or peripheral cutting edges

16. Describe the Steps to calculate R.P.M for $\varnothing 22$ slot drill with $V_c = 100$ and also calculate its Feed Rate with feed per tooth 0.15.?

$$V_c = 3.14 \times D \times N / 1000$$

$$N = V_c \times 1000 / 3.14 \times D$$

$$N = 1448$$

$$F_z = \text{feed per tooth} \times \text{rpm}$$

$$F_z = 0.15 \times 1448$$

$$F_z = 217$$

17. Explain the following: -

- Horizontal milling machine
- Vertical milling machine.

► Horizontal milling machine

On a horizontal milling machine, the milling spindle is positioned horizontally. A steady with an adjustable support bearing enables the milling cutter to shift axially. Several milling cutters can be applied at the same time. Horizontal milling machines are used to mill longer workpieces with uniform surface profiles.

► Vertical milling machine

On a vertical milling machine, in contrast to horizontal milling machines, the milling spindle is positioned vertically. The milling head pivots and the milling cutter can be adjusted vertically within the milling head.

18. Differentiate up milling and down milling with a suitable diagram?

► Conventional milling

In this process, the feed motion runs contrary to the cutting motion of the milling cutter. The cutting edges slide over the workpiece surface and cut into the material at the interface with high pressure. The resulting friction causes increased wear on the tool flanks. As the material is cut, a force (F_1) is exerted on the workpiece. Because the cutting force (F_2) works against the workpiece, a force (F_r) develops which attempts to loosen the workpiece from the clamping equipment. Faulty clamping may cause diminished surface quality and even force the workpiece out of the clamping equipment. Due to the opposing forces, some play in the feed device has a positive affect. Conventional milling can be performed on all milling machines.

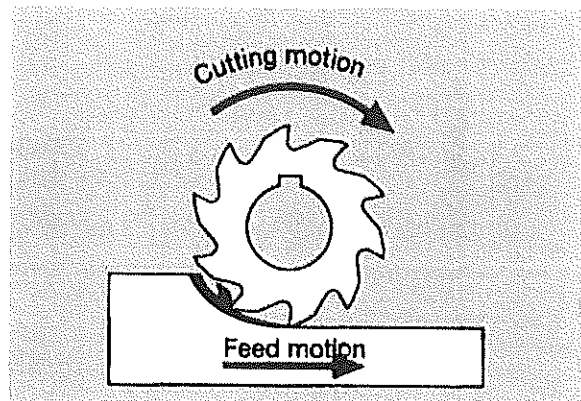

► Down milling

In this process, the workpiece feed motion operates in the same direction as the cutting motion of the milling cutter. The cutting edges cut abruptly into the surface of the workpiece and make the largest cut right at the beginning. As the material is cut, a force (F_1) is exerted on the workpiece. The cutting force (F_2) works in the direction of the feed motion. The resulting force (F_r) attempts to pull the workpiece under the milling cutter. In order to oppose this, the milling machine's feed drive must function backlash-free; it must be capable of controlling the forces that develop. Down milling enables larger cutting depths compared to conventional milling; therefore, it can only be performed on especially stable milling machines.

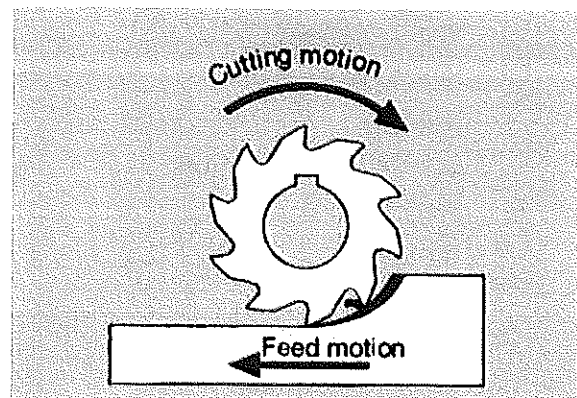



BHARTIYA SKILL DEVELOPMENT UNIVERSITY

Registration No.:

Set A

School of Manufacturing Skills

Session: 2020-21 (Summer Semester)

B. Voc. Program, I Semester,

End-Sem. Examination

Course Code: SMS1104

Time: 2 Hour

Course Name: Conventional Turning

Max. Marks: 50

Instructions:

1. Attempt all questions.
2. Section A contains 10 Questions. Each question carries 1 Mark.
3. Section B contains 04 Questions. Each question carries 4 Marks.
4. Section C contains 04 Questions. Each question carries 6 Marks.

Section – A

10X01 = 10 Marks

1. Which of the following operation produce chipless thread?
 - a) Swirl machining
 - b) Thread- milling
 - c) Grinding
 - d) Rolling
2. Pitch is defined as -
 - a) The distance between two consecutive threads
 - b) The distance between major diameter to minor diameter
 - c) The distance between major diameter to Pitch circle diameter
 - d) The diagonal Distance between flank face to root
3. In lathe machine, the correct sequence for external thread-
 - a) Undercut, chamfer, turning & threading
 - b) Chamfer, undercut, turning & threading
 - c) Turning, undercut, chamfer & Threading
 - d) Turning, chamfer, threading & Undercut
4. Why we make undercut in thread?
 - a) Thread tool relaxation & Self-looking.
 - b) To clean the face
 - c) To reduce the diameter
 - d) None of the above



BHARTIYA SKILL DEVELOPMENT UNIVERSITY

5. In tool geometry, $\alpha + \beta + \gamma = \dots\dots\dots$
 - a) 60 degree
 - b) 30 degree
 - c) 90 degree
 - d) 180 degree
6. Chuck is used to clamp rectangular workpiece-
 - a) Collet chuck
 - b) Three jaw chuck
 - c) Four jaw chuck
 - d) None of the above
7. Short designation for a 30 mm trapezoidal thread is-
 - a) Tr 30 × 6
 - b) Ta 30 × 6
 - c) Tp 30 × 6
 - d) Tz 30 × 6
8. Short designation for a 30 mm round thread is-
 - a) Rd 30 × ½
 - b) Ro 30 × ½
 - c) Rr 30 × ½
 - d) Ru 30 × ½
9. Which thread is capable to bear heavy load in both direction?
 - a) V – shaped Threads
 - b) Trapezoidal Threads
 - c) Withworth Threads
 - d) Buttress Threads
10. Which of the following is not the mode of action of the screw?
 - a) Measuring
 - b) Tensioning
 - c) Setting and moving
 - d) Undercut

Section – B

04X04 = 16 Marks

11. Write difference between right hand tool and left hand tool? (with neat sketch)
12. A bar to be plain turned to a diameter of 36 mm. What is the speed of rotation n , if the cutting speed is $V_c = 61$ m/min?
13. Write down the specification of metric thread and explain any five of them? (with neat sketch)
14. Write the short note on Withworth thread.



BHARTIYA SKILL DEVELOPMENT UNIVERSITY

Section – C

04X06 = 24 Marks

15. Define Average roughness value (Ra) and Average maximum height of the profile (Rz). Also, which value is greater for the same surface roughness?
16. Write down the classification of thread?
17. Why do we do centering of turning tools before machining? (with a neat sketch)
18. Name different types of chips formation and explain it? (with a neat sketch)







BHARTIYA SKILL DEVELOPMENT UNIVERSITY

Registration No.:

School of Manufacturing Skills
Session: 2020-21 (Summer Semester)
B. Voc. Program, I Semester,
End-Sem. Examination

Course Code: SMS1104

Course Name: Conventional Turning

Time: 2 Hour

Max. Marks: 50

Answer Key

Section – A

10X01 = 10 Marks

1. Which of the following operation produce chipless thread?
 - a) Swirl machining
 - b) Thread- milling
 - c) Grinding
 - d) **Rolling**
2. Pitch is defined as -
 - a) **The distance between two consecutive threads**
 - b) The distance between major diameter to minor diameter
 - c) The distance between major diameter to Pitch circle diameter
 - d) The diagonal Distance between flank face to root
3. In lathe machine, the correct sequence for external thread-
 - a) Undercut, chamfer, turning & threading
 - b) Chamfer, undercut, turning & threading
 - c) **Turning, undercut, chamfer & Threading**
 - d) Turning, chamfer, threading & Undercut
4. Why we make undercut in thread?
 - a) **Thread tool relaxation & Self-looking.**
 - b) To clean the face
 - c) To reduce the diameter
 - d) None of the above
5. In tool geometry, $\alpha + \beta + \gamma = \dots\dots\dots$
 - a) 60 degree
 - b) 30 degree
 - c) **90 degree**
 - d) 180 degree

6. Chuck is used to clamp rectangular workpiece-
 - a) Collet chuck
 - b) Three jaw chuck
 - c) **Four jaw chuck**
 - d) None of the above
7. Short designation for a 30 mm trapezoidal thread is-
 - a) **Tr 30 × 6**
 - b) Ta 30 × 6
 - c) Tp 30 × 6
 - d) Tz 30 × 6
8. Short designation for a 30 mm round thread is-
 - a) **Rd 30 × ½**
 - b) Ro 30 × ½
 - c) Rr 30 × ½
 - d) Ru 30 × ½
9. Which thread is capable to bear heavy load in both direction?
 - a) V – shaped Threads
 - b) **Trapezoidal Threads**
 - c) Withworth Threads
 - d) Buttress Threads
10. Which of the following is not the mode of action of the screw?
 - a) Measuring
 - b) Tensioning
 - c) Setting and moving
 - d) **Undercut**

Section – B

04X04 = 16 Marks

11. Write difference between right hand tool and left hand tool? (with neat sketch)

Ans

cutting tool are also characterized by the arrangement of their main cutting edge

Left hand tool

When the direction of tool feed is from left to right then a left hand cutting tool must be in used.

When viewed from the workpiece the major cutting edge lies on the left side of the cutting tool.

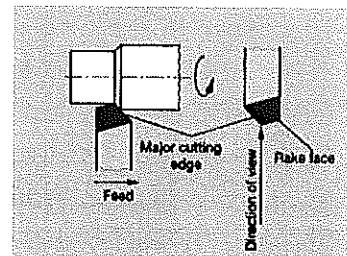

Right hand tool

With the right hand cutting tool the direction of feed is from right to left.

Looking at the cutting head of the lathe tool the main cutting edge is on the right hand side.

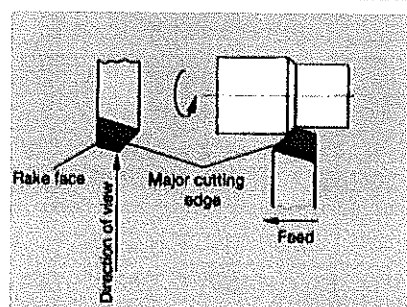

12. A bar to be plain turned to a diameter of 36 mm. What is the speed of rotation n , if the cutting speed is $V_c=61$ m/min?

given: $d=36$ mm

$$v_c = 61 \text{ m/min}$$

required

$$\text{Answer: } v_c = d \cdot \pi \cdot n$$

$$n = \frac{v_c}{d \cdot \pi}$$

$$n = \frac{61 \text{ m/min}}{0.036 \text{ m} \times 3.14}$$

$$n = \frac{61 \text{ m/min}}{0.11304 \text{ m}}$$

$$n = 539.6 \text{ min}^{-1}$$

13. Write down the specification of metric thread and explain any five of them? (with neat sketch)

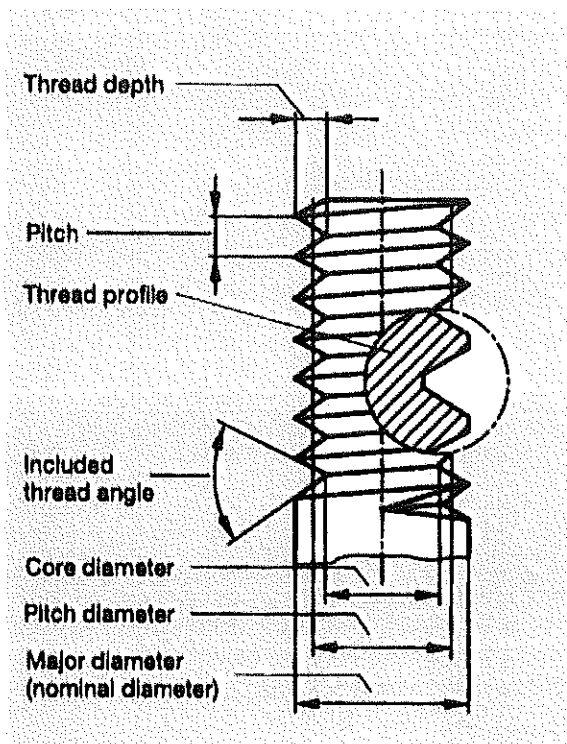

- ▶ **Nominal diameter:** the external thread diameter
- ▶ **Core diameter:** on an external thread, this is the diameter of the remaining cross-section. On internal threads, it is approximately the same as the diameter of the bore hole.
- ▶ **Pitch diameter:** this is approximately halfway between the nominal diameter and the core diameter.
- ▶ **Included thread angle:** the included thread angle is the angle between the thread flanks.
- ▶ **Pitch:** the pitch is the axial distance from thread turn to thread turn.
- ▶ **Thread depth:** this indicates how far into the material the thread profile goes.
- ▶ **Thread profile:** this indicates the shape of the thread.

14. Write the short note on Whitworth thread.

3.5 Whitworth pipe thread

The Whitworth pipe thread for threaded pipes and fittings according to DIN EN 10 226 is used in gas, water and heating installation engineering. It has a small pitch and is regarded as a fine thread. The thread connection consists of a cylindrical internal thread and a tapered outer thread (taper 1:16).

The combination of the cylindrical internal thread and the tapered outer thread ensures that the pipe connection is already largely sealed through the pressing of metal on metal. A sealing agent is inserted when the connection is screwed together. This should even out any small imperfections in the thread surface and increase the sealing power.

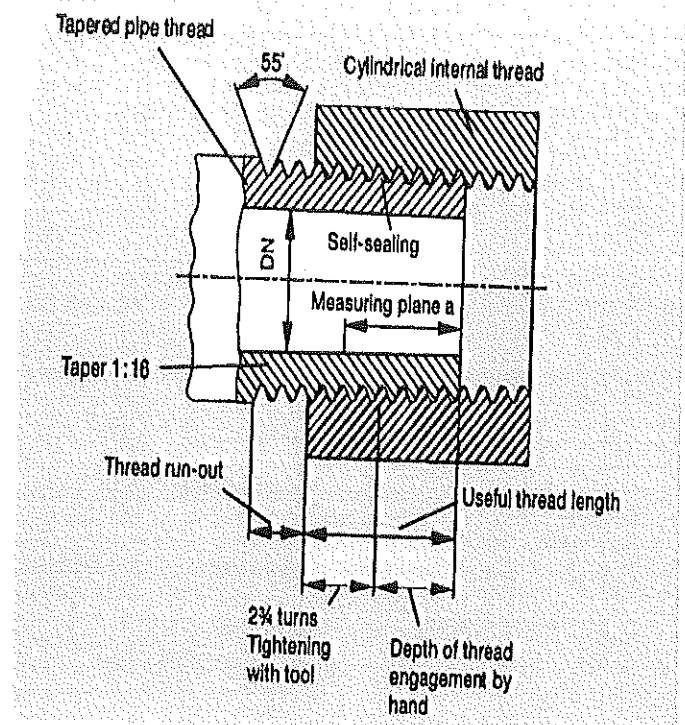

Section – C

04X06 = 24 Marks

15. Define Average roughness value (R_a) and Average maximum height of the profile (R_z). Also, which value is greater for the same surface roughness?

R_a = Mean Peak to Valley Height

The Mean Peak to Valley Height (R_a) is the mean of all deviations in the roughness profile from the median line. It is given in Microns.

R_z = Averaged peak to valley Height

The Averaged peak to valley Height is mean figure obtained from five successive individual Sections. For this purpose, an assessment length (l_a) divided up into five equal measurement section. This distance between highest and lowest profile point is then measured for each section. This distance is referred to as the individual peak to valley height (Z). The formula for calculating the mean peak to valley height is as follow

$$R_z = 1/5 (Z_1 + Z_2 + Z_3 + Z_4 + Z_5)$$

For same surface roughness R_z value is greater

16. Write down the classification of thread?

Thread are classified according to four factors:

1 Purpose

We distinguish between fastening threads and motion –transmitting threads.

Fastening threads

Generally single- threaded V-shaped thread with an included angle of 60 degree and maximum lead angle of 5 degree

Motion transmitting threads



BHARTIYA SKILL DEVELOPMENT UNIVERSITY

Used to convert rotational motion into linear motion or vice versa. The profile changes according to load application

2 Direction of rotation

Right-hand thread

Left-hand thread

If you hold a screw vertically, the thread turns rise towards the right with a right-hand thread and towards the left with a left-hand thread.

Threads are normally right-handed.

A left-hand thread is only used if a right-hand thread would come unscrewed (e.g. grinding wheel fastening, turnbuckle, bicycle pedals) or if there is a risk of confusion (gas bottles).

LH (left hand) is added to the thread designation, e.g. M 16-LH.

3 number of threads

Single-Threaded

Multi- Threaded

You can tell the number of thread turns from the thread starts.

Single-threaded is the most common type.

For the double-threaded type, the pitch is twice the pitch of the single-threaded type, which means that a large axial motion is achieved with a small rotation (screw presses, worms).

4 profile

V-shaped thread

V-shaped thread

All V-shaped threads have small lead angles and are used as fastening threads. Their thread profile has a triangular shape.

Trapezoidal thread

Trapezoidal threads

can be axially loaded in two directions. The included thread angle is 30°. The thread has "crest clearance", i.e. the thread turns must have "clearance" on the core diameter and on the major diameter of the bolt.

When used as a motion-transmitting thread, it is often multi-threaded and can withstand high loads.

Buttress thread

Round thread

Buttress threads

are particularly suited to high, one-sided, axial loads. The load-bearing flank side is approximately perpendicular to the screw axis. The thread is centred on the major diameter. The high level of filleting on the thread turns on the bolt core reduces the notch effect, thereby increasing the load capacity.

Round threads

are less sensitive to damage and dirt. They are therefore primarily used for fittings, hose connections, railway couplers, bulb holders, etc.

17. Why do we do centering of turning tools before machining? (with a neat sketch)

Ans. Positioning the tool below the midpoint of the workpiece increases the clearance angle and reduces the rake angle, the tool will catch and cause an uneven surface to be produced.

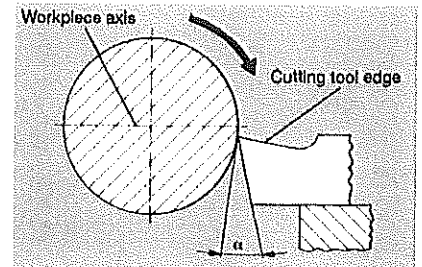

Positioning the tool above the midpoint of the work piece reduces the clearance angle and increases the rake angle, the lathe tool will dig in.

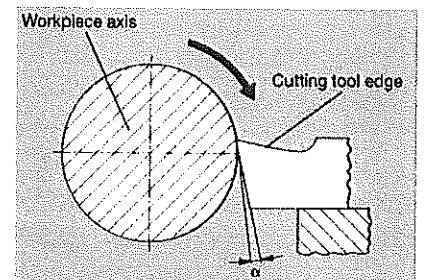

Optimum machining is only possible when the lathe tool is accurately aligned to the midpoint of the work piece, as the clearance and Rake angles are then in the correct relationship to the work piece.

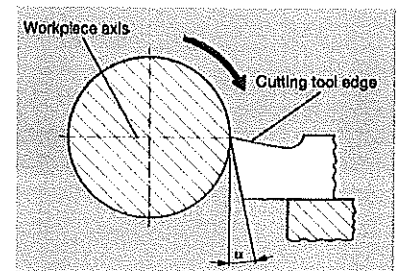

18. Name different types of chips formation and explain it? (with a neat sketch)

Ans.

The can be draw between the following types

Tear chip

Are short irregular in shape, as they are Tron from the material. Tear chips mainly result from rough working. when using larger depth of cut, low cutting speed and larger rate of feed

Continuous chip

Are long and continuous thy are produced when machining soft materials and usually result from high cutting speeds using a cutting tool with large rake angle. Continuous chip tend to disturb the machining operation because they are often difficult to remove

Shear chip

Are irregular continuous. They are produced when cutting ductile material using medium cutting speeds and small to medium rack angles. The surface finish of the workpiece is not comparable to that archived when producing continuous chips



BHARTIYA SKILL DEVELOPMENT UNIVERSITY

Registration No.:

Set B

School of Manufacturing Skills

Session: 2020-21 (Summer Semester)

B. Voc. Program, I Semester,

End-Sem. Examination

Course Code: SMS1104

Course Name: Conventional Turning

Time: 2 Hour

Max. Marks: 50

Instructions:

1. Attempt all questions.
2. Section A contains 10 Questions. Each question carries 1 Mark.
3. Section B contains 04 Questions. Each question carries 4 Marks.
4. Section C contains 04 Questions. Each question carries 6 Marks.

Section – A

10X01 = 10 Marks

1. ASB-45° Tool is Used for
 - (A) Internal Grooving
 - (B) Boring Finish
 - (C) Boring Rough
 - (D) Internal Threading

2. Pitch is defined as
 - (A) The distance between two consecutive threads
 - (B) The distance between major diameter to minor diameter
 - (C) The distance between major diameter to Pitch circle diameter
 - (D) The diagonal Distance between flank face to root

3. In lathe machine, the correct sequence for external thread
 - (A) Undercut, chamfer, turning & threading
 - (B) Chamfer, undercut, turning & threading
 - (C) Turning, undercut, chamfer & Threading
 - (D) Turning, chamfer, threading & Undercut

4. Why we make undercut in thread?
 - (A) Thread tool relaxation & Self-looking.
 - (B) To clean the face
 - (C) To reduce the diameter
 - (D) None of the above



BHARTIYA SKILL DEVELOPMENT UNIVERSITY

5. In lathe machine, tailstock is used for:
- (A) Supporting long shaft
 - (B) Drilling
 - (C) Reaming
 - (D) All of the above
6. ECS-90° Tool is Used for :
- (A) Internal Grooving
 - (B) Boring Finish
 - (C) Boring Rough
 - (D) Internal Threading
7. Why do we use coolant?
- (A) To increase tool life
 - (B) To improve the surface finish of the work piece
 - (C) To reduce the surface temperature of the work piece
 - (D) All of the above
8. Which one is the correct answer?
- (A) $V_c = \frac{\pi dn}{1000} \text{ cm/min}$
 - (B) $V_c = \frac{\pi dn}{1000} \text{ mm/min}$
 - (C) $V_c = \frac{\pi dn}{1000} \text{ m/min}$
 - (D) $V_c = \frac{\pi dn}{1000} \text{ m/sec.}$
9. Which thread is capable to bear heavy load in both direction?
- (A) V – shaped Threads
 - (B) Acme Threads
 - (C) Knuckle Threads
 - (D) Buttress Threads
10. What is the use of rake angle in a tool?
- (A) Chips removal
 - (B) Provide space between work piece and tool
 - (C) To give relief
 - (D) None of these



BHARTIYA SKILL DEVELOPMENT UNIVERSITY

Section – B

04X04 = 16 Marks

11. What are the factor which influence tool life?
12. Write difference between right hand tool and left hand tool? (with neat sketch)
13. Define:
 - A. Tool wedge angle
 - B. Clearance angle
 - C. Rake angle
14. A shaft of 60 mm diameter is to be plain turned. The lathe is turning at a speed of 120min-1. What is the cutting speed $1V_c$ in m/min?

Section – C

04X06 = 24 Marks

15. For thread M36X3, calculate: -
 - (a) Thread depth
 - (b) Required chamfer
 - (c) Minor diameter
16. Define Average roughness value (Ra) and Average maximum height of the profile (Rz).
17. Which value is greater for the same surface roughness?
18. Name different types of chips formation and explain it? (with a neat sketch)
19. Why do we do centering of turning tools before machining? (with a neat sketch)

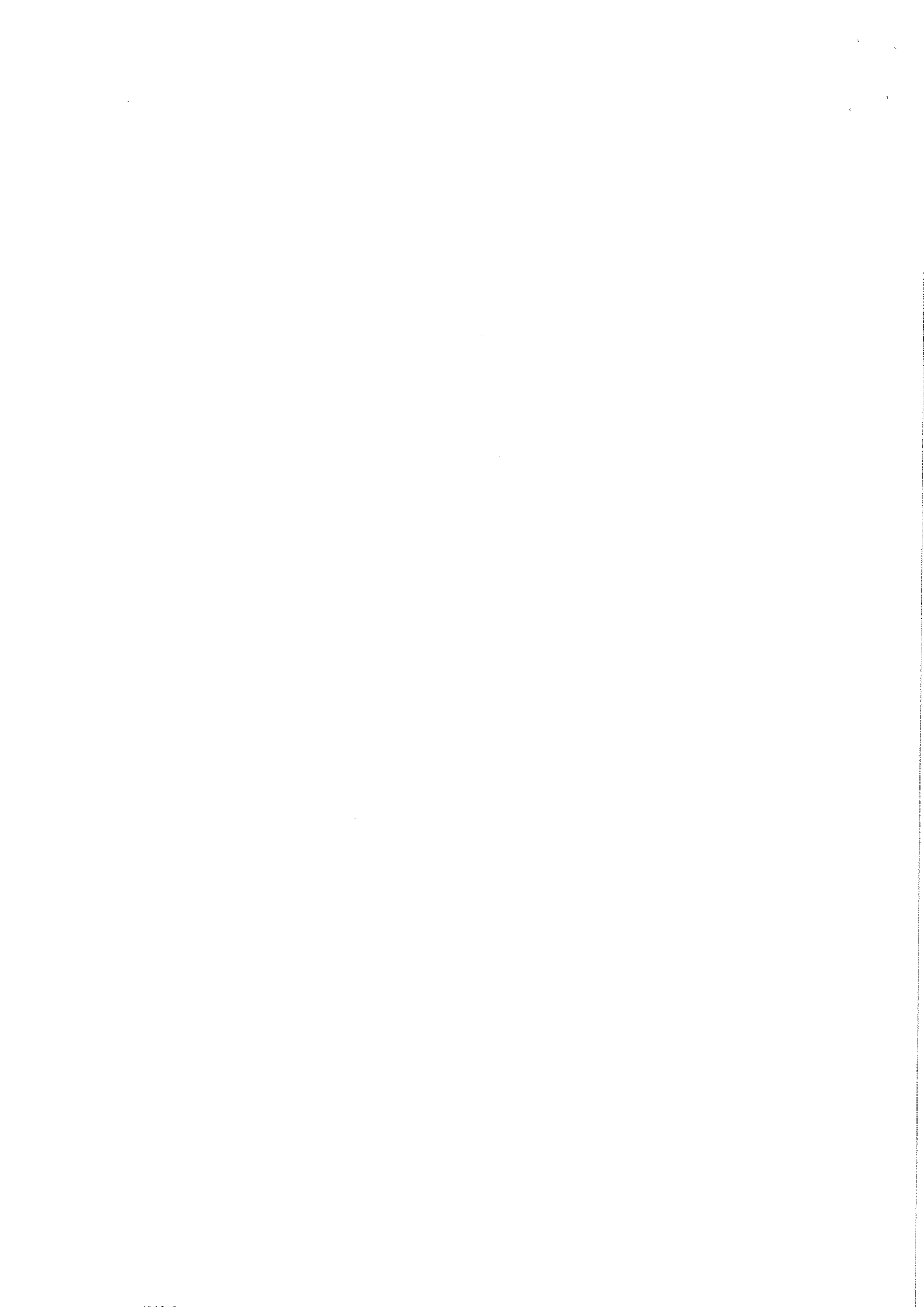



BHARTIYA SKILL DEVELOPMENT UNIVERSITY

Registration No.:

School of Manufacturing Skills
Session: 2020-21 (Summer Semester)
B. Voc. Program, I Semester,
End-Sem. Examination

Course Code: SMS1104

Course Name: Conventional Turning

Time: 2 Hour

Max. Marks: 50

Answer Key

Section – A

10X01 = 10 Marks

1. ASB-45° Tool is Used for
 - (A) Internal Grooving
 - (B) Boring Finish
 - (C) Boring Rough**
 - (D) Internal Threading

2. Pitch is defined as
 - (A) The distance between two consecutive threads**
 - (B) The distance between major diameter to minor diameter
 - (C) The distance between major diameter to Pitch circle diameter
 - (D) The diagonal Distance between flank face to root

3. In lathe machine, the correct sequence for external thread
 - (A) Undercut, chamfer, turning & threading
 - (B) Chamfer, undercut, turning & threading
 - (C) Turning, undercut, chamfer & Threading**
 - (D) Turning, chamfer, threading & Undercut

4. Why we make undercut in thread?
 - (A) Thread tool relaxation & Self-looking.**
 - (B) To clean the face
 - (C) To reduce the diameter
 - (D) None of the above

5. In lathe machine, tailstock is used for:
 - (A) Supporting long shaft
 - (B) Drilling
 - (C) Reaming
 - (D) All of the above**



BHARTIYA SKILL DEVELOPMENT UNIVERSITY

6. ECS-90° Tool is Used for :
- (A) Internal Grooving
 - (B) Boring Finish**
 - (C) Boring Rough
 - (D) Internal Threading
7. Why do we use coolant?
- (A) To increase tool life
 - (B) To improve the surface finish of the work piece
 - (C) To reduce the surface temperature of the work piece
 - (D) All of the above**
8. Which one is the correct answer?
- (A) $V_c = \frac{\pi dn}{1000} \text{ cm/min}$
 - (B) $V_c = \frac{\pi dn}{1000} \text{ mm/min}$
 - (C) $V_c = \frac{\pi dn}{1000} \text{ m/min}$**
 - (D) $V_c = \frac{\pi dn}{1000} \text{ m/sec.}$
9. Which thread is capable to bear heavy load in both direction?
- (A) V – shaped Threads
 - (B) Acme Threads**
 - (C) Knuckle Threads
 - (D) Buttress Threads
10. What is the use of rake angle in a tool?
- (A) Chips removal**
 - (B) Provide space between work piece and tool
 - (C) To give relief
 - (D) None of these

Section – B

04X04 = 16 Marks

11. What are the factor which influence tool life?

Ans.

Machine cutting imposes mechanical and thermal stress on the cutting edge. This alter its original properties and it becomes blunt.

tool life is influenced by:

The cutting condition (cutting speed, bit shape, cutting profile)

The tool itself (cutting material, grinding quality)

The workpiece (material and shape)

The coolant lubricant used

12. Write difference between right hand tool and left hand tool? (with neat sketch)
cutting tool are also characterized by the arrangement of their main cutting edge

Left hand tool

When the direction of tool feed is from left to right then a left hand cutting tool must be in used. When viewed from the workpiece the major cutting edge lies on the left side of the cutting tool.

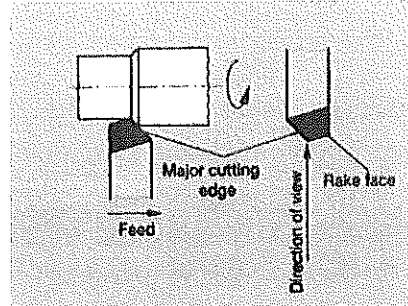

Right hand tool

With the right hand cutting tool the direction of feed is from right to left. Looking at the cutting head of the lathe tool the main cutting edge is on the right hand side.

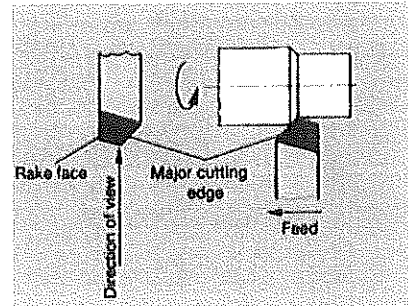

13. Define:

- Tool wedge angle
- Clearance angle
- Rake angle

- Tool wedge angle (beta)
This is the angle between the rake angle face and the flank face. A larger wedge angle is required when the material being cut is of high strength. When cutting softer materials, the wedge angle can be correspondingly smaller
- Clearance angle (alpha)
This is the angle between the surface of the workpiece and the flank of the cutting wedge. Clearance angle of 6 degrees to 8 degrees are effective for metal working purposes.
- Rake angle (gamma)
The rake angle has a major impact on chip formation. The rake angle lies between the horizontal line from the cutting surface and rake face

14. A shaft of 60 mm diameter is to be plain turned. The lathe is turning at a speed of 120min⁻¹.
What is the cutting speed v_c in m/min?

Ans given: $d=60\text{mm}$

$$n=120 \text{ min}^{-1}$$

required: v_c

$$\text{Answer: } v_c = d \cdot \pi \cdot n$$

$$v_c = 60\text{mm} \times 3.14 \times 120 \text{ min}^{-1}$$

$$v_c = 0.60\text{m} \times 3.14 \times 120 \text{ min}^{-1}$$

$$v_c = 22.6\text{m/min}$$



BHARTIYA SKILL DEVELOPMENT UNIVERSITY

Section – C

04X06 = 24 Marks

15. For thread M36X3, calculate: -

(a) Thread depth

(b) Required chamfer

(c) Minor diameter

(a) Thread depth = $0.614 \times \text{pitch}$

$$= 0.614 \times 3$$

$$= 1.842 \text{ mm (radially)}$$

Thread depth (diametrically) = 2×1.842

$$= 3.684 \text{ mm}$$

(b). Required Chamfer = $\frac{\text{major dia.} - \text{minor dia.}}{2} + 0.5$

$$= \frac{35.7 - 32.1}{2} + 0.5$$

$$= 2.3 \text{ mm (approx.)}$$

(c). Minor diameter = major dia. – thread depth

$$= 35.7 - 3.6$$

$$= 32.1 \text{ mm}$$

16. Define Average roughness value (R_a) and Average maximum height of the profile (R_z).

Which value is greater for the same surface roughness?

Ans.

R_a = Mean Peak to Valley Height

The Mean Peak to Valley Height (R_a) is the mean of all deviations in the roughness profile from the median line. It is given in Microns.

R_z = Averaged peak to valley Height

The Averaged peak to valley Height is mean figure obtained from five successive individual Sections. For this purpose, an assessment length (l_e) divided up into five equal measurement section. This distance between highest and lowest profile point is then measured for each section. This distance is referred to as the individual peak to valley height (Z). The formula for calculating the mean peak to valley height is as follow

$$R_z = 1/5 (Z_1 + Z_2 + Z_3 + Z_4 + Z_5)$$

For same surface roughness R_z value is greater.



BHARTIYA SKILL DEVELOPMENT UNIVERSITY

17. Name different types of chips formation and explain it? (with a neat sketch)

Ans.

The can be draw between the following types

Tear chip

Are short irregular in shape, as they are Tron from the material. Tear chips mainly result from rough working. when using larger depth of cut, low cutting speed and larger rate of feed

Continuous chip

Are long and continuous thy are produced when machining soft materials and usually result from high

cutting speeds using a cutting tool with large rake angle. Continuous chip tend to disturb the machining operation because they are often difficult to remove

Shear chip

Are irregular continuous. They are produced when cutting ductile material using medium cutting speeds and small to medium rack angles. The surface finish of the workpiece is not comparable to that archived when producing continuous chips

18. Why do we do centering of turning tools before machining? (with a neat sketch)

Ans. Positioning the tool below the midpoint of the workpiece increases the clearance angle and reducesthe rake angle, the tool will catch and cause an uneven surface to be produced.

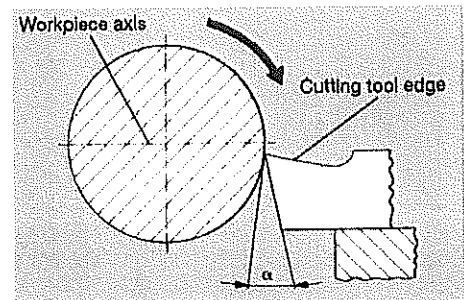

Positioning the tool above the midpoint of the work piece reduces the clearnace angle and increases the rake angle, the lathe tool will dig in.

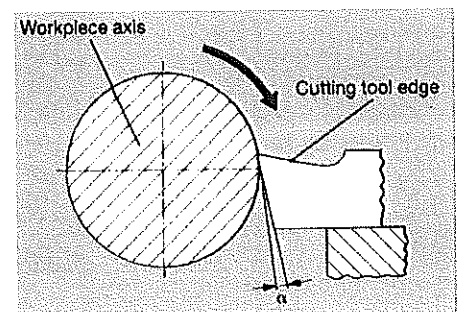

Optimum machining is only possible when the lathe tool is accurately aligned to the midpoint of the work piece, as the clearance and Rake angles are then in the correct relationship to the work piece.

