



# BHARTIYA SKILL DEVELOPMENT UNIVERSITY

Registration No.: .....

## School of Manufacturing Skills

Session: 2021-22 (Summer Semester)

B. Voc. Program, III Semester,

2<sup>nd</sup> In-Sem. Examination

Course Code: GEN1302

Time: 1 Hour

Course Name: Computer Aided Drawing

Max. Marks: 20

### Instructions:

1. Attempt all questions.
2. Use of Calculators is Prohibited.
3. Section A contains 05 Questions. Each question carries 1 Mark.
4. Section B contains 03 Questions. Each question carries 2 Marks.
5. Section C contains 03 Questions. Each question carries 3 Marks.

### Section – A

05X01 = 05 Marks

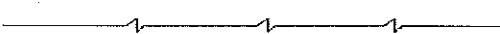
1. The command which is used to create a round corner between two lines is \_\_\_\_\_
  - a) Chamfer
  - b) Fillet
  - c) Stretch
  - d) Extend
2. Which among the following is the softest pencil of all?
  - a) 2B
  - b) 3B
  - c) H
  - d) 2H
3. The line given below is used for \_\_\_\_\_  

  - a) Long-break line
  - b) Cutting planes
  - c) Centroidal lines
  - d) Out lines of adjacent parts
4. Which among the following is the correct full form of GD&T?
  - a) Geometric dimensioning and tolerancing
  - b) General dimensioning and tolerancing
  - c) Geometric dimensioning and tolerance
  - d) Geometric dimension and tolerance
5. 0.01 mm is equivalent to \_\_\_\_\_ microns.
  - a) 1 microns
  - b) 10 microns
  - c) 100 microns
  - d) None of these



# BHARTIYA SKILL DEVELOPMENT UNIVERSITY

## Section – B

03X02 = 06 Marks

6. What do you mean by index number in the drawing?
7. Describe the different type of lines used in engineering drawing.
8. Why does A0 size paper have exactly the size of 841 X 1189mm?

## Section – C

03X03 = 09 Marks

9. What information should be available in a layout of engineering drawing?
10. Differentiate between Engineering drawing and Artistic drawing with the help of diagrams.
11. What do you mean by the layout of an engineering drawing, explain with the help of a diagram?



# BHARTIYA SKILL DEVELOPMENT UNIVERSITY

Registration No.: .....

## School of Manufacturing Skills

Session: 2021-22 (Summer Semester)

B. Voc. Program, III Semester,

2<sup>nd</sup> In-Sem. Examination

Course Code: GEN1302

Time: 1 Hour

Course Name: Computer Aided Drawing

Max. Marks: 20

### Answer Key Section – A

05X01 = 05 Marks

1. The command which is used to create a round corner between two lines is \_\_\_\_\_

b) Fillet

2. Which among the following is the softest pencil of all?

b) 3B

3. The line given below is used for \_\_\_\_\_



a) Long-break line

4. Which among the following is the correct full form of GD&T?

a) Geometric dimensioning and tolerancing

5. 0.01 mm is equivalent to \_\_\_\_\_ microns.

b) 10 microns

### Section – B







03X02 = 06 Marks

6. What do you mean by index number in the drawing?

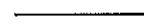
Ans. Index No. tells us the No. of revisions any particular drawing has been gone through and that particular No. mentioned in the drawing is the revised drawing.

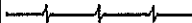
7. Describe the different type of lines are used in engineering drawing.

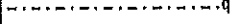
Ans.

Illustration	Application
Thick 	Outlines, visible edges, surface boundaries of objects, margin lines
Continuous thin 	Dimension lines, extension lines, section lines leader or pointer lines, construction lines, boarder lines
Continuous thin wavy 	Short break lines or irregular boundary lines – drawn freehand
Continuous thin with zig-zag 	Long break lines
Short dashes, gap 1, length 3 mm 	Invisible or interior surfaces
Short dashes 	Center lines, locus lines Alternate long and short dashes in a proportion of 6:1,
Long chain thick at end and thin elsewhere 	Cutting plane lines

8. Why does A0 size paper have exactly the size of 841 X 1189mm?

Ans. We have standardized the A0 area as 1 square meter in rectangle form therefore it is deduced as 841 x 1189 mm.

### Section – C

03X03 = 09 Marks

9. What information should be available in a layout of engineering drawing?

Ans.

Shape of an object
Exact Sizes and tolerances of various parts of the object
The finish of the product
Machine cost
Machining sequence
The details of materials
Catalogue no. of the product
Date on which the drawing was made
The person who made the drawing
The company's name

10. Differentiate between Engineering drawing and Artistic drawing with the help of diagrams?

Ans.

### Technical drawing

- It is a system of graphic representation of various types of objects or structures. Its purpose is to provide sufficient information to facilitate its design, construction, and maintenance. It is usually done today with the help of computerized media. They are usually made on paper or other types of flat media.
- This type of drawing is based on descriptive geometry and uses orthogonal projections to draw the different views of an object, plane, part, machine and others.
- The technical drawing follows internationally approved regulations to unify the language used. However, each country has a body that normalizes the study and approval of the rules to follow.
- It includes sketches, sketches, diagrams, and electrical, mechanical, architectural and urban planning plans.

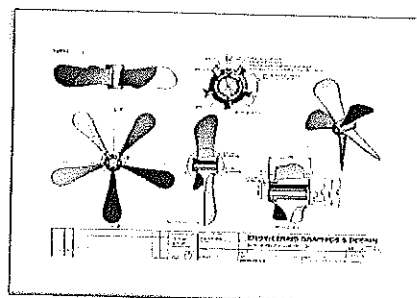

## Artistic drawing

- It is about the discipline of drawing and delineating figures or abstract forms that represent a real or imaginary object. It is a form of graphic expression.
- It has been used since prehistory as a language of universal characteristic that allows the transmission of information, descriptions, ideas and feelings.
- Its purpose is aesthetic, is to convey an idea or feeling.
- You can copy existing drawings or models to train observation and motor skills while other artists use their imagination.
- Difference between technical drawing and artistic drawing
- The technical drawing is a form of representation of objects that follows a set of international standards.
- Artistic drawing is the free representation of feelings, actions and ideas.

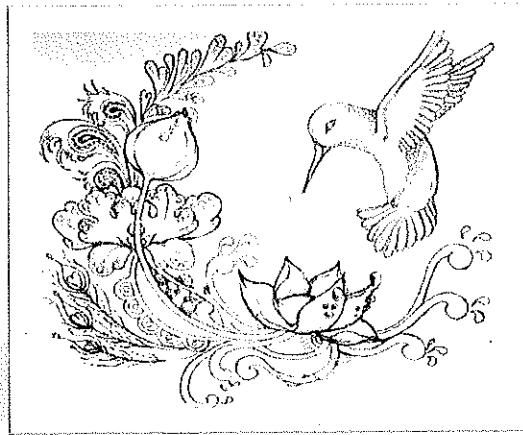

11. What do you mean by the layout of an engineering drawing explain with the help of a diagram?

Ans. Layout: An engineering drawing has to follow a standard format in which the drawing sheet consists of drawing space, title block and sufficient margins is called layout of engineering drawing.

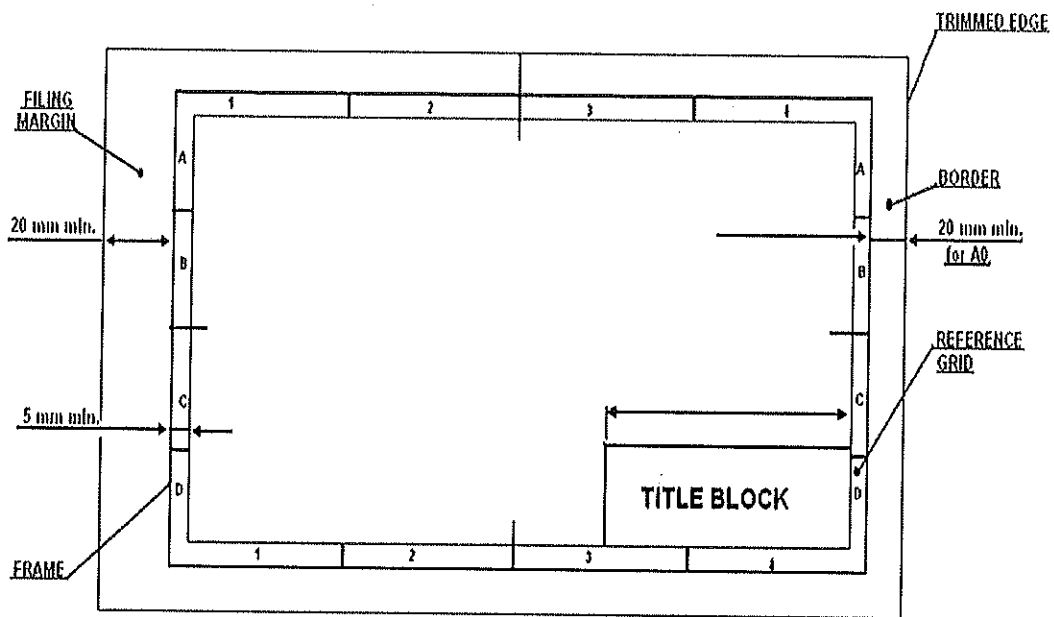



**School of Manufacturing Skills**

Session: 2021-22 (Summer Semester)

B. Voc. Program, III Semester,

2<sup>nd</sup> In-Sem. Examination

Course Code: GEN1305

Time: 1 Hour

Course Name: Elementary Drawing

Max. Marks: 20

**Instructions:**

1. Attempt all questions.
2. Use of Calculators is Prohibited.
3. Section A contains 05 Questions. Each question carries 1 Mark.
4. Section B contains 03 Questions. Each question carries 2 Marks.
5. Section C contains 03 Questions. Each question carries 3 Marks.

**Section – A**

05X01 = 05 Marks

1. What does this symbol represent?

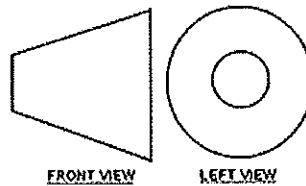

- a) 4<sup>th</sup> angle projection
  - b) 3<sup>rd</sup> angle projection
  - c) 2<sup>nd</sup> angle projection
  - d) 1<sup>st</sup> angle projection
2. Which measuring instrument is required to measure angle?
    - a) Vernier caliper
    - b) Bevel protector
    - c) Ring gauge
    - d) Micrometer
  3. What does this symbol represent?

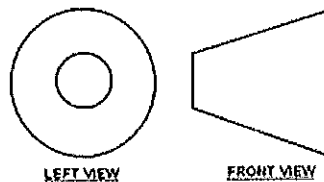

- a) 4<sup>th</sup> angle projection
- b) 3<sup>rd</sup> angle projection
- c) 2<sup>nd</sup> angle projection
- d) 1<sup>st</sup> angle projection



# BHARTIYA SKILL DEVELOPMENT UNIVERSITY

4. Distance from the observer to the object is finite and the object is viewed from single point, is a characteristic of which view?
- parallel view
  - perspective view
  - both (a) and (b)
  - none of the above
5. Which line type is use to show the cutting plane line?
- Long chain thick at the end and thin elsewhere
  - to show the hollow areas
  - none of the above
  - long chain thin at the end and thick elsewhere

## Section – B

03X02 = 06 Marks

6. Draw the missing view from given figure?

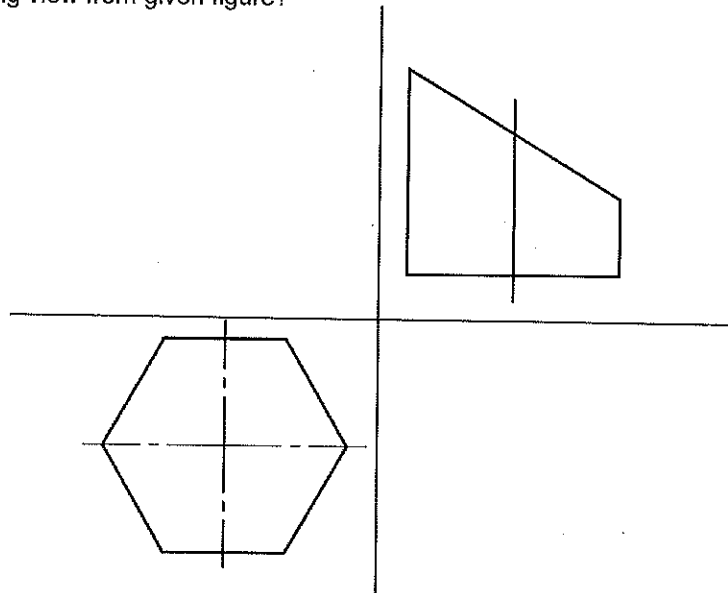

7. Explain what is orthographic projection?
8. Draw different types of lines and write down their application.

## Section – C

03X03 = 09 Marks

9. Explain 1<sup>st</sup> angle projection with an appropriate example.
10. Explain 3<sup>rd</sup> angle projection with an appropriate example.
11. Draw the orthographic projection
- the view from the front,
  - the view from the right and
  - the view from the left of the object

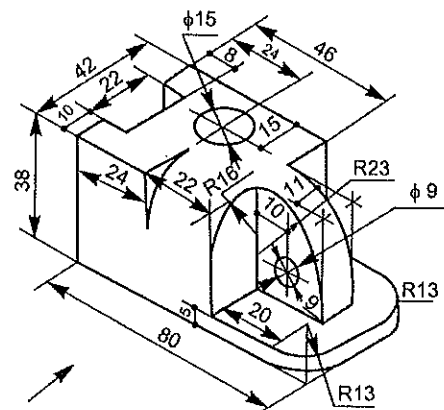



**School of Manufacturing Skills**

Session: 2021-22 (Summer Semester)

B. Voc. Program, III Semester,

2<sup>nd</sup> In-Sem. Examination

Course Code: GEN1305

Time: 1 Hour

Course Name: Elementary Drawing

Max. Marks: 20

Answer Key

Section – A

05X01 = 05 Marks

1. What does this symbol represent?  
d) **1st angle projection**
2. Which measuring instrument is required to measure angle?  
b) **Bevel protector**
3. What does this symbol represent?  
b) **3<sup>rd</sup> angle projection**
4. Distance from the observer to the object is finite and the object is viewed from single point, is a characteristic of which view?  
b) **perspective view**
5. Which line type is use to show the cutting plane line?  
a) **Long chain thick at the end and thin elsewhere**



Section – B

03X02 = 06 Marks

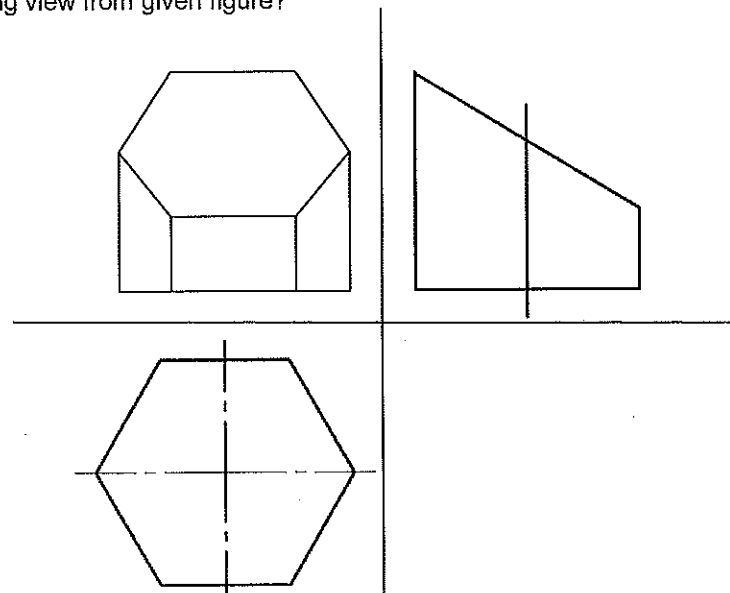
1. Draw the missing view from given figure?

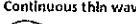
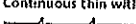
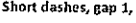
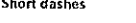
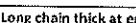

2. Explain what is orthographic projection?  
Ans Orthographic projection is a Parallel Projection Technique in which the plane of projection is perpendicular to the parallel line of sight.  
There are two ways of drawing in orthographic - First Angle and Third Angle.
3. Draw different types and write down their application.

Illustration	Application
Thick 	Outlines, visible edges, surface boundaries of objects, margin lines
Continuous thin 	Dimension lines, extension lines, section lines leader or pointer lines, construction lines, boarder lines
Continuous thin wavy 	Short break lines or irregular boundary lines – drawn freehand
Continuous thin with zig-zag 	Long break lines
Short dashes, gap 1, length 3 mm 	Invisible or interior surfaces
Short dashes 	Center lines, locus lines Alternate long and short dashes in a proportion of 6:1,
Long chain thick at end and thin elsewhere 	Cutting plane lines

### Section – C

03X03 = 09 Marks

4. Explain 1<sup>st</sup> angle projection with an appropriate example.
  - Ans In this the object is assumed to be positioned in the first quadrant
  - The object is assumed to be positioned in between the projection planes and the observer. The views are obtained by projecting the images on the respective planes.
  - Note that the right hand side view is projected on the plane placed at the left of the object.
  - After projecting on to the respective planes, the bottom plane and left plane is unfolded on to the front view plane. i.e. the left plane is unfolded towards the left side to obtain the Right hand side view on the left side of the Front view and aligned with the Front view. The bottom plane is unfolded towards the bottom to obtain the Top view below the Front view and aligned with the Front View.
5. Explain 3<sup>rd</sup> angle projection with an appropriate example.
  - Ans In the third angle projection method, the object is assumed to be in the third quadrant. i.e. the object behind vertical plane and below the horizontal plane.
  - In this projection technique, Placing the object in the third quadrant puts the projection planes between the viewer and the object.
6. Draw the orthographic projection
  - (i) the view from the front,
  - (ii) the view from the right and
  - (iii) the view from the left of the object

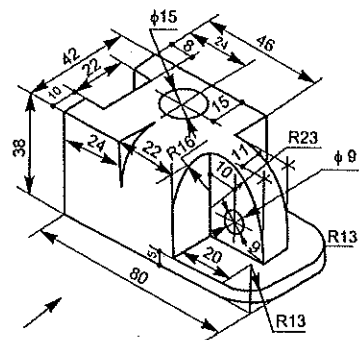
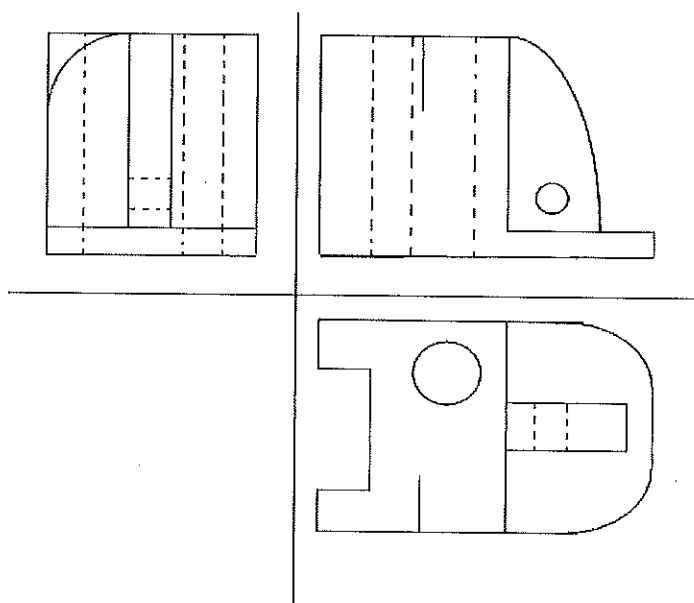



**School of Manufacturing Skills**

**Session: 2021-22 (Summer Semester)**

**B. Voc. Program, III Semester,**

**2<sup>nd</sup> In-Sem. Examination**

**Course Code: SMS1302**

**Time: 1 Hour**

**Course Name: CNC Turning**

**Max. Marks: 20**

**Instructions:**

1. Attempt all questions.
2. Section A contains 05 Questions. Each question carries 1 Mark.
3. Section B contains 03 Questions. Each question carries 2 Marks.
4. Section C contains 03 Questions. Each question carries 3 Marks.

**Section – A**

05X01 = 05 Marks

1. G01 is named as:
  - a) Circular Interpolation Clockwise
  - b) Rapid Traverse
  - c) Linear Interpolation
  - d) Circular Interpolation Counterclockwise
2. G-Code used for Dwell is:
  - a) G01
  - b) G02
  - c) G03
  - d) G04
3. Reference point is denoted by:
  - a) M
  - b) W
  - c) R
  - d) N
4. M01 is used for:
  - a) Optional Stop
  - b) Main Program End
  - c) Sub-Program End
  - d) Tool Change
5. G02 is used for:
  - a) Circular interpolation clockwise
  - b) Circular interpolation anticlockwise
  - c) Rapid traverse
  - d) Linear interpolation



# BHARTIYA SKILL DEVELOPMENT UNIVERSITY

## Section – B

03X02 = 06 Marks

6. Write down the syntax of Finishing Cycle.
7. Write down the formulas for calculating Major Diameter, Thread Depth, Minor Diameter and Chamfer for External Metric Threads.
8. What will be the Spindle Rotation and Tool Movement for making Left Hand Threads?

## Section – C

03X03 = 09 Marks

9. Explain Contour Turning Cycle in detail.
10. Write down the format of G78 Cycle.
11. What is Grooving Cycle?



# BHARTIYA SKILL DEVELOPMENT UNIVERSITY

Registration No.: .....

## School of Manufacturing Skills

Session: 2021-22 (Summer Semester)

B. Voc. Program, III Semester,

2<sup>nd</sup> In-Sem. Examination

Course Code: SMS1302

Course Name: CNC Turning

Time: 1 Hour

Max. Marks: 20

### Answer Key

#### Section – A

05X01 = 05 Marks

1. G01 is named as:  
**c) Linear Interpolation**
2. G-Code used for Dwell is:  
**d) G04**
3. Reference point is denoted by:  
**c) R**
4. M01 is used for:  
**a) Optional Stop**
5. G02 is used for:  
**a) Circular Interpolation clockwise**

#### Section – B

03X02 = 06 Marks

6. Write down the syntax of Finishing Cycle.

#### Format

N... G72 P... Q...

P..... Block number of the first block for the program of finishing shape.

Q ..... Block number of the last block for the program of finishing shape.

7. Write down the formulas for calculating Major Diameter, Thread Depth, Minor Diameter and Chamfer for External Metric Threads.

$$\text{Major Dia.} = \text{Nominal Dia.} + 10\% \text{ of Pitch}$$

$$\text{Thread Depth} = 0.614 \times \text{Pitch}$$

$$\text{Minor Dia.} = \text{Major Dia.} - (2 \times \text{Thread Depth})$$

$$\text{Chamfer} = \text{Thread Depth} + 0.3$$

8. What will be the Spindle Rotation and Tool Movement for making Left Hand Threads?

*Spindle Rotation = Clockwise*

*Tool Movement = Away from Chuck*

#### Section – C

03X03 = 09 Marks

9. Explain Contour Turning Cycle in detail.



# BHARTIYA SKILL DEVELOPMENT UNIVERSITY

**Format**

N... G73 U<sub>1</sub>... R...  
 N... G73 P... Q... U<sub>2</sub>+/-... W+/-... F... S... T...

- first block U<sub>1</sub> [mm] depth of cut, incremental, without sign, in the drawing shown as U<sub>1</sub>
- R [mm] retract height
- second block P..... block number of the first block for the programmed shape
- Q ..... block number of the last block for the programmed shape
- U<sub>2</sub> [mm] distance and direction of finishing offset in X direction (diameter or radius designation), in the drawing shown as U<sub>2</sub>/2
- W [mm] Distance and direction of finishing offset in Z direction, incremental, without sign
- F, S, T Feed, speed, tool

10. Write down the format of G78 Cycle.

**Format**

N... G78 P<sub>1</sub>... Q<sub>1</sub>... R<sub>1</sub>...  
 N... G78 X(U)... Z(W)... R<sub>2</sub>... P<sub>2</sub>... Q<sub>2</sub>... F...

first block:

P<sub>1</sub>..... is a 6 digit parameter divided in digit couples:

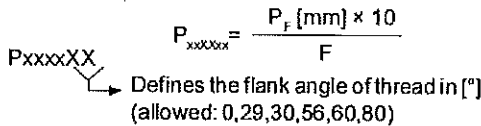
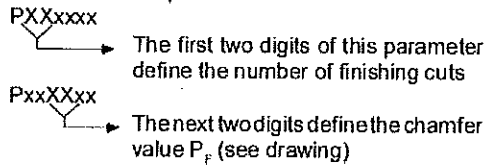

- Q<sub>1</sub>..... Minimum cutting depth [μm] incremental
- R<sub>1</sub>..... Finishing offset [mm] incremental

- second block X(U), Z(W) Absolute (incremental) coordinates of the point K
- R<sub>2</sub> [mm] Incremental taper value with sign (R=0 cylindrical thread)
- P<sub>2</sub> [μm] Thread depth (always positive), in the drawing shown as P<sub>2</sub>
- Q<sub>2</sub> [μm] Cutting depth of the first cut (radius value) without sign
- F [mm] Thread pitch

11. What is Grooving Cycle?

**Format**

N... G77 R<sub>1</sub>...  
 N... G77 X(U)... Z(W)... P... Q... R<sub>2</sub>... F...

- first block R<sub>1</sub> [mm] Retraction height for chip breaking, in the drawing shown as R<sub>1</sub>
- sec. block X(U), Z(W) Absolute (incremental) coordinates of K
- P [μm] Cutting depth in X direction (no sign)
- Q [μm] Incremental infeed in Z direction (no sign)
- R ..... Undercut at X end point, in the drawing shown as R<sub>2</sub>
- F ..... Feed



# BHARTIYA SKILL DEVELOPMENT UNIVERSITY

Registration No.: .....

## School of Manufacturing Skills

Session: 2021-22 (Summer Semester)

B. Voc. Program, III Semester,

2<sup>nd</sup> In-Sem. Examination

Course Code: SMS1305

Time: 1 Hour

Course Name: Material Science

Max. Marks: 20

### Instructions:

1. Attempt all questions.
2. Use of Calculators is Prohibited.
3. Section A contains 05 Questions. Each question carries 1 Mark.
4. Section B contains 03 Questions. Each question carries 2 Marks.
5. Section C contains 03 Questions. Each question carries 3 Marks.

### Section – A

05X01 = 05 Marks

1. Which quenching agent is use to quench alloy steel?
  - a) Oil
  - b) Water
  - c) Water oil emulsion
  - d) Circulating air
2. Pig iron contains ----- iron.
  - a) 90 %
  - b) 80%
  - c) 92%
  - d) 82%
3. \_\_\_\_\_ refers to a permanent change in micro-structure and properties caused by heat exposure.
  - a) Forging
  - b) Heat treatment
  - c) Welding
  - d) Casting
4. Pig iron is manufactured in which furnace?
  - a) Electric arc furnace
  - b) Puddling Furnace
  - c) Cupola Furnace
  - d) Blast furnace
5. Which one is not a mechanical properties of material?
  - a) Toughness
  - b) Hardness
  - c) Brittleness
  - d) Electric conductivity



# BHARTIYA SKILL DEVELOPMENT UNIVERSITY

## Section – B

03X02 = 06 Marks

6. What is a refining process in production of steel?
7. Write down any two mechanical properties of material.
8. Write down any two production properties of material.

## Section – C

03X03 = 09 Marks

9. Explain Basic Oxygen process with suitable diagram.
10. Explain process of extraction of pig iron.
11. Write a short note on-
  - a) Annealing
  - b) Hardening
  - c) Quenching



# BHARTIYA SKILL DEVELOPMENT UNIVERSITY

Registration No.: .....

## School of Manufacturing Skills

Session: 2021-22 (Summer Semester)

B. Voc. Program, III Semester,

2<sup>nd</sup> In-Sem. Examination

Course Code: SMS1305

Course Name: Material Science

Time: 1 Hour

Max. Marks: 20

### Answer Key

#### Section – A

05X01 = 05 Marks

1. Which quenching agent is use to quench alloy steel?  
a) Oil
2. Pig iron contains ----- iron.  
c) 92%
3. \_\_\_\_\_ refers to a permanent change in micro-structure and properties caused by heat exposure.  
b) Heat treatment
4. Pig iron is manufactured in which furnace?  
d) Blast furnace
5. Which one is not a mechanical properties of material?  
d) Electric conductivity

#### Section – B

03X02 = 06 Marks

6. What is a refining process in production of steel?  
To produce steel from cast iron from pig iron, the carbon content has to be reduced and the undesired accompanying substance have to be almost entirely eliminated. This process is called refining.
7. Write down any two mechanical properties of material.  
Hardness: Hardness refers to the resistance with which a material counters indent formation by a test indenter. Hard materials include hardened steel and hard metals. Soft materials include aluminium and copper.  
Brittleness: A material is referred to as brittle if it fractures into pieces when exposed to impact. Ceramic material and glass as well as some types of cast iron and incorrectly hardened steels are brittle.
8. Write down any two production properties of material.  
Machinability: It indicates whether and under which conditions a material can be manufactured using machining techniques, such as turning, milling and grinding. The surface quality of the machined surface, the machining conditions and the service life of the machine tools are quantifying parameters for the machinability.  
Weldability: It describes the suitability or unsuitability of a material for welding. Unalloyed and low alloy steels with a low carbon content have good welding properties. High alloy steels as well as aluminium and copper alloys can also be welded using special welding methods.

9. Explain Basic Oxygen process with suitable diagram.

### Basic Oxygen Process

The basic oxygen process takes place in a converter. The converter is loaded with Scrap iron and liquid Pig Iron in the filling position. It is then raised and oxygen is blown onto the pig iron melt at 8 to 12 bar. This leads to a fierce reaction between the oxygen and the iron contaminants so that the melt boils. Lime is now added. It forms a liquid slag on the melt and binds the solid combustion products and the undesired iron contaminants. The carbon in the Pig Iron is almost completely burnt up to form CO and CO<sub>2</sub>, which rise as gases, during the refining process. The required alloying components and deoxidation agents are added at the end of refining process, before pouring the steel. The steel is then first poured through the converter's opening into the casting ladle provided. The slag is then poured off over the edge of the converter.

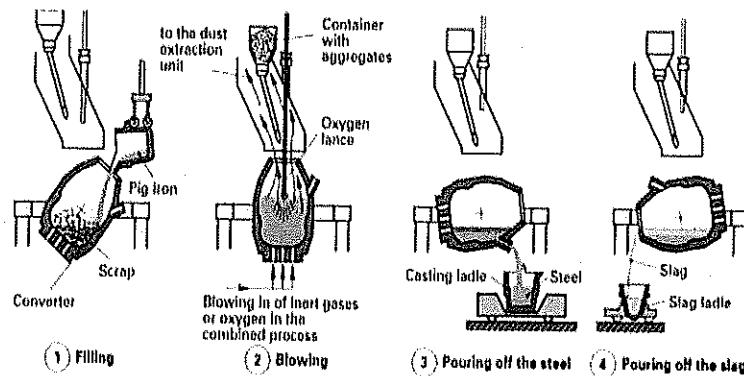

11. Explain process of extraction of pig iron.

Extraction of PIG Iron - Steel and Iron Casting alloys are produced from Pig Iron. Pig Iron itself is extracted from Iron Ore in blast furnace. Processes in the blast furnace. The blast furnace is loaded in layers with mixture of iron ore, aggregates and coke. The aggregates absorb the ore components of the iron ore when melting. The coke is partially burnt up by the hot air that is blown in and provides the melting heat for the input materials. The remainder of the coke reduces the iron ore to metallic iron. It contains carbon released from the coke. The resulting liquid pig iron collects at the bottom of the blast furnace. It is released in run offs.

12. Write a short note on-

- Annealing** - Annealing is a heat treatment that consists of slow heating, holding at an annealing temperature and slow cooling.
- Hardening** - Hardening consists of several working steps. The workpiece is first heated to the hardening temperature and then held at this temperature. It is then quenched, i.e. immersed in water or oil. This makes the steel very hard, but also brittle and fragile. As a result, the workpiece is then tempered, i.e. heated to the tempering temperature. The workpiece is then air cooled. This gives steel its customary hardness.
- Quenching** - Rapid quenching of the workpiece heated to the hardening temperature is achieved by immersion in water or oil, in emulsions by blasting with air. When quenching, the position of the workpiece during immersion and its movement in the quenching fluid is important in order to ensure that it is even and does not lead to hardening distortions. The vapour bubbles that form on the hot workpiece surface must quickly dissipate. Vapour bubbles that adhere to the to the surface act as thermal insulation and prevent the uniform cooling of the workpiece.



# BHARTIYA SKILL DEVELOPMENT UNIVERSITY

Registration No.: .....

School of Manufacturing Skills  
Session: 2021-22 (summer Semester)  
B. Voc. Program, III Semester,  
2<sup>nd</sup> In-Sem. Examination

Course Code: SMS1308

Time: 1 Hour

Course Name: Metrology & Measuring Instruments

Max. Marks: 20

Instruction:

1. Attempt all questions.
2. Use of Calculators is Prohibited.
3. Section A contains 05 Questions. Each question carries 1 Mark.
4. Section B contains 03 Questions. Each question carries 2 Marks.
5. Section C contains 03 Questions. Each question carries 3 Marks.

## Section – A

05X01 = 05 Marks

1. Full form of BIPM:
  - a) Servo Power Amplifier
  - b) International Bureau of Weights and Measures
  - c) Service position Amplifier
  - d) Service power Amplifier
2. How many standards used for length measurements?
  - a) 5
  - b) 2
  - c) 3
  - d) 4
3. Which device is used for angular measurements?
  - a) Refractometer
  - b) Autocollimator
  - c) Tachometer
  - d) Dial caliper
4. Magnification is the process which is used for?
  - a) Reduction in size
  - b) Enlarging in size
  - c) All of the above
  - d) None of these
5. The word metrology actually derives from the Greek words which are?
  - a) Metro and logy
  - b) Metron and logos
  - c) Metro and logo
  - d) Measure and logo



# BHARTIYA SKILL DEVELOPMENT UNIVERSITY

## Section – B

03X02 = 06 Marks

6. Define Metrology.
7. Explain any two.
  - A. Sensitivity
  - B. Magnification
  - C. Calibration
8. Write the types of error which occurs in sine bar?

## Section – C

03X03 = 09 Marks

9. Write down the applications and advantages of CMM.
10. Explain working principle of sine bar.
11. Explain the accuracy and precision.



# BHARTIYA SKILL DEVELOPMENT UNIVERSITY

Registration No.: .....

School of Manufacturing Skills  
Session: 2021-22 (summer Semester)  
B. Voc. Program, III Semester,  
2<sup>nd</sup> In-Sem. Examination

Course Code: SMS1308

Time: 1 Hour

Course Name: Metrology & Measuring Instruments

Max. Marks: 20

## Answer Key

### Section – A

05X01 = 05 Marks

1. Full form of BIPM  
b) International Bureau of Weights and Measures
2. How many standards used for length measurements?  
c) 3
3. Which device is used for angular measurements?  
b) Autocollimator
4. Magnification is the process which is used for.  
a) Reduction in size
5. The word metrology actually derives from the Greek words which are.  
b) Metron and logos

### Section – B

03X02 = 06 Marks

6. Define Metrology.  
ANS. The word metrology actually derives from the Greek words 'metron' and 'logos' which translated means the study of measurement.
7. Explain any two.

#### SENSITIVITY

Sensitivity is an absolute quantity, the smallest absolute amount of change that can be detected by a measurement.

#### CALIBRATION

In measurement technology and metrology, **calibration** is the comparison of measurement values delivered by a device under test with those of a calibration standard of known accuracy. Such a standard could be another measurement device of known accuracy, a device generating the quantity to be measured such as a voltage, a sound tone, or a physical artifact, such as a meter ruler.

#### MAGNIFICATION

**Magnification** is the process of enlarging the apparent size, not physical size, of something. This enlargement is quantified by a calculated number also called "magnification". When this number is less than one, it refers to a reduction in size, sometimes called magnification or de-magnification.

Typically, magnification is related to scaling up visuals or images to be able to see more detail, increasing resolution, using microscope, printing techniques, or digital processing. In all cases, the magnification of the image does not change the perspective of the image.

8. Write the types of error which occur in sine bar.

**Types of errors in sine bar:**

**Progressive Angle Error:**

This error occurs due to error in the distance of centers of two rollers.

**Content Angle Error:**

This error occurs when the surface of the component and the roller axes are not parallel to each other.

### Section – C

03X03 = 09 Marks

9. Write down the applications of CMM.

**Ans.** Application of CMM

- ✓ Aerospace Industries
- ✓ Automotive
- ✓ Food processing
- ✓ Healthcare
- ✓ Paper
- ✓ Pharmaceuticals
- ✓ Plastics
- ✓ Research and development
- ✓ Semiconductor

10. Explain working principle of sine bar.

Ans. Sine Bar is a precise angle measuring instrument. It is used to measure angles very accurately or to align the work piece at a given angle. Sine Bar is the most accurate instrument for measuring angles.

Sine bar is made up of high carbon high chromium corrosion resistance steel. Sine bar is made with this material so that it can avoid wear and tear of sine bar when handling. As the tear and wear are avoided, the errors are eliminated and the accuracy of the sine bar is maintained.

**Working Principle of Sine Bar:**

The principle of operation of the sine bar is based on the law of trigonometry.

If one roller of sine bar is placed on the surface plate and the other roller is placed on the height of slip gauges, then the structure formed by the sine bar, surface plate, and slip gauges forms a triangle.

The **hypotenuse** of this triangle is the sine bar, **perpendicular** is formed by combination of slip gauges and the surface plate is the **base**.

Suppose the height of slip gauges is **H** and the length of the sine bar is **L**, then sine ratio the angle theta will be **H** divided by **L**.

Now the angle  $\theta$  can be calculated as **sin inverse** of **H** divided by **L**.

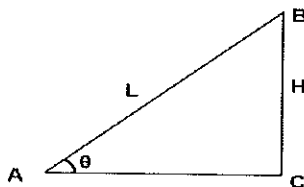

**Sine Bar Working Principle**

$$\sin\theta = \frac{H}{L} \text{ or } \sin\theta = \frac{BC}{AB}$$

$$\theta = \sin^{-1} \left( \frac{H}{L} \right)$$

11. Explain the accuracy and precision.

### ACCURACY AND PRECISION

In the fields of science and engineering the accuracy of a measurement system is the degree of closeness of measurements of a quantity to that quantity's true value. The precision of a measurement system, related to reproducibility and repeatability, is the degree to which repeated measurements under unchanged conditions show the same results.

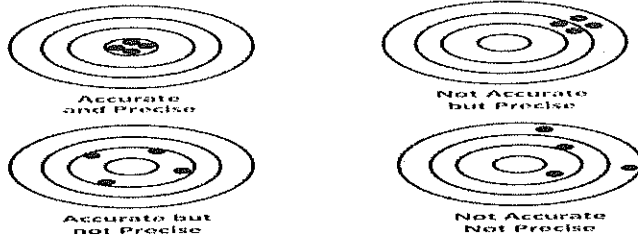

Accuracy	Precision
Accuracy is closeness with the true value of the quantity being measured.	Precision is a measure of the reproducibility of the measurement.
Measurement can be accurate but not necessarily precise.	Measurement can be precise but not necessarily accurate.
It can be determined with a single measurement.	It needs several measurements to be determined.
Accuracy may be affected with systematic error.	Precision may be affected with random error.
Accurate values have to be precise in most cases.	Precise values may or may not be accurate.
Degree of conformity.	Degree of reproducibility.

10

7