



School of Electrical Skills
Third Semester, End Semester Examination
B. Voc. Program, Winter Semester, (Session: 2018-19)

Course Code: ELE 1301**Time: 3 Hours****Course Name: Electrical Assembly Operator Control Panel****Max. Marks: 100**

Instructions: Answer all questions from section A, each question carries two marks. Answer any six questions from section B, each question carries five marks. Answer all questions from section C, each question carries ten marks. Scientific calculator can be used.

Section – A**10x2=20 Marks**

- Q.1 (A) For household wiring and small units, which of the following should be used for safety measure:
(a) MCB (b) ACB (c) OCB (d) MCCB
- (B) Which of the following colour is used for radiation hazard?
(a) Red (b) Orange (c) Green (d) Purple
- Q.2 (A) Power factor of a pure capacitive load is:
(a) 0 (b) 1 (c) range from 0 to 1 (d) None of These
- (B) The "Straight rating" refers to:
(a) A solidly grounded wye (b) Delta systems
(c) Ungrounded wye systems (d) None of These
- Q.3 (A) Which of the following is an electromagnetic relay?
(a) Attracted armature type (b) Induction Type (c) both a and b (d) None of these.
- (B) Which of the following is a symmetrical fault?
(a) LG Fault (b) LLG Fault (c) LLLG Fault (d) LL Fault
- Q.4 (A) An isolation transformer is used in:
(a) protective extra low voltage circuit (b) protective extra high voltage circuit
(c) protective low voltage circuit (d) protective extra high voltage circuit
- (B) Which of the following is an attracted armature type relay?
(a) Plunger type relay (b) Balance Beam type relay (c) Polarized relay (d) All of these
- Q.5 (A) The faults are automatically detected by _____ and faulty section is isolated by _____.
(a) Relay, Circuit breaker (b) Circuit breaker, Relay
(c) Relay, Relay (d) Circuit breaker, Circuit breaker.
- (B) The average value of a complete sine wave for a complete cycle is:
(a) 0 (b) 1 (c) varies between 0 to 1 (d) None of the above
- Q.6 (A) The full form of NFPA is:
(a) National Fire Prediction Association (b) National Fire Protection Association
(c) National Finance Projection Association (d) None of the above
- (B) A salesman tells you that his microwave is rated at 3000 kW. Comment about the statement.
(A) The statement is correct (b) The statement is incorrect (c) None of the above
- Q.7 (A) Which of the following is correct?
(a) $I_{rms} = 2I_m/\pi$ (b) $I_{rms} = I_m/\pi$ (c) $I_{rms} = I_m/\sqrt{2}$ (d) None of these
- (B) Given, $V = 5\sin 100\pi t$ find the frequency f :
(a) 50Hz (b) 120Hz (c) 60 Hz (d) None of these
- Q.8 (A) What is the RMS value of a certain sine wave represented by $I = 10\sin 120\pi t$ A?
(a) 7.071 V (b) 3.535 V (c) 10 V (d) 1.17 V
- (B) What are the basic requirements of a protective relaying?
(a) Reliability (b) Selectivity (c) Speed (d) All of These
- Q.9 (A) Causes of circuit breaker failure is mainly due to:
(a) Failure of main contacts (b) Mechanical failure of tripping mechanism
(c) Open or short-circuit trip coil (d) All of these
- (B) Two or more faults may occur simultaneously on a system. Such faults are known as:
(a) Multiple faults (b) Simultaneous faults (c) both a and b (d) none of these

Q.10 (A) Fuse holders used in power circuit for branch circuit protection shall not be marked for:

- (a) Power (b) Voltage (c) Current (d) Fuse Type

(B) An electrical outlet that connects an electrical device to an electricity supply is known as:

- (a) pin (b) plug (c) receptacle (d) socket

Section – B

6x5=30 Marks

Answer any six questions.

- Q. 1. What are Instrument transformers? Give their advantages and uses.
Q. 2. Explain the working of balanced beam relay.
Q. 3. Derive the expression for the relationship between line voltage and phase voltage for a “delta” connected system and comment about straight rating.
Q. 4. What are the different types of faults in power system?
Q. 5. What are ratio and phase angle error in current transformer (CT)? Give causes and remedies for them.
Q. 6. What is meant by an Electric Hazard? What are the types of electric hazards?
Q. 7. Find the values of current in each loop of the bellow circuit.

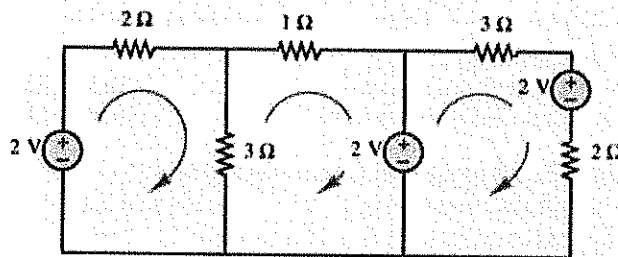

- Q. 8. What are the advantages of induction cup type relay over induction disc type relay?

Section – C

5x10=50 Marks

- Q. 1. Draw the voltage, current and power waveforms of following circuit. Also, comment on the average power.
a. R Circuit
b. RL Circuit when $R > L$
c. RL Circuit when $R < L$
d. RC circuit when $R > C$
e. RC circuit when $R < C$
Q. 2. Write a short note on feeder circuit and branch circuit with the help of a suitable diagram.
Q. 3. Explain how the rotating magnetic field is created in 3 phase induction machine.
Q. 4. A 4 pole 50Hz induction machine calculate the rotor frequency in following condition:
a. At stand still
b. Motor is running at 1440 rpm in same direction of field
Q. 5. Derive the expression for torque produced by an induction relay.



Answer Key
Registration No. _____

School of Electrical Skills
Third Semester, End Semester Examination
B. Voc. Program, Winter Semester, (Session: 2018-19)

Course Code: ELE 1301
Course Name: Electrical Assembly Operator Control Panel

Time: 3 Hours
Max. Marks: 100

Instructions: Answer all questions from section A, each question carries two marks. Answer any six questions from section B, each question carries five marks. Answer all questions from section C, each question carries ten marks. Scientific calculator can be used.

Section – A 10x2=20 Marks

Q.1 (A) For household wiring and small units, the following should be used for safety measure:
(a) MCB (b) ACB (c) OCB (d) MCCB

Ans. (a)

(B) Which of the following colour is used for radiation hazard?
(a) Red (b) Orange (c) Green (d) Purple

Ans. (d)

Q.2 (A) Power factor of a pure capacitive load is:
(a) 0 (b) 1 (c) range from 0 to 1 (d) None of These

Ans. (a)

(B) The "Straight rating" refers to:
(a) A solidly grounded wye (b) Delta systems
(c) Ungrounded wye systems (d) None of These

Ans. (b)

Q.3 (A) Which of the following is an electromagnetic relay?
(a) Attracted armature type (b) Induction Type (c) both a and b (d) None of these.

Ans. (c)

(B) Which of the following is a symmetrical fault?
(a) LG Fault (b) LLG Fault (c) LLLG Fault (d) LL Fault

Ans. (c)

Q.4 (A) A safety transformer is used in:
(a) protective extra low voltage circuit (b) protective extra high voltage circuit
(c) protective low voltage circuit (d) protective extra high voltage circuit

Ans. (a)

(B) Which of the following is an attracted armature type relays?
(a) Plunger type relay (b) Balance Beam type relay (c) Polarized relay (d) All of these

Ans. (d)

Q.5 (A) The Faults are automatically detected by _____ and faulty section is isolated by _____.
(a) Relay, Circuit breaker (b) Circuit breaker, Relay
(c) Relay, Relay (d) Circuit breaker, Circuit breaker.

Ans. (a)

(B) The average value of a sine wave is:
(a) 0 (b) 1 (c) varies between 0 to 1 (d) None of the above

Ans. (a)

Q.6 (A) The full form of NFPA is:
(a) National Fire Prediction Association (b) National Fire Protection Association
(c) National Finance Projection Association (d) None of the above

Ans. (b)

(B) A salesman tells you that his microwave is rated at 3000 kW. Comment about the statement.
(A) The statement is correct (b) The statement is Incorrect (c) None of the above

Ans. (a)

Q.7 (A) Which of the following is correct?
(a) $I_{rms} = 2I_m/\pi$ (b) $I_{rms} = I_m/\pi$ (c) $I_{rms} = I_m/\sqrt{2}$ (d) None of these

Ans. (c)

(B) Given, $V = 5\sin 100\pi t$ find the frequency f .
(a) 50Hz (b) 120Hz (c) 60 Hz (d) None of these

Ans. (a)

Q.8 (A) What is the RMS value of a certain sine wave represented by $I=10\sin 120\pi t$ A?
(a) 7.071 V (b) 3.535 V (c) 10 V (d) 1.17 V

Ans. (a)

(B) What are the basic requirements of a protective relaying?
(a) Reliability (b) Selectivity (c) Speed (d) All of These

Ans. (d)

Q.9 (A) Causes of circuit breaker failure is mainly due to:
(a) Failure of main contacts (b) Mechanical failure of tripping mechanism
(c) Open or short-circuit trip coil (d) All of these

Ans. (d)

(B) Two or more faults may occur simultaneously on a system. Such faults are known as:
(a) Multiple faults (b) Simultaneous faults (c) both a and b (d) none of these

Ans. (c)

Q.10 (A) Fuse holders used in power circuit for branch circuit protection shall not be marked for:
(a) Power (b) Voltage (c) Current (d) Fuse Type

Ans. (a)

(B) An electrical outlet that connects an electrical device to an electricity supply is known as:
(a) pin (b) plug (c) receptacle (d) socket

Ans. (c)

Section – B

6x5=30 Marks

Answer any six questions.

Q. 1. What are Instrument transformers? Give their advantages and uses.

Ans.

Usually protective relays are not directly connected to the system. To provide low level equivalents of system currents and voltages relays are connected through current and/or voltage transformers. These are known as instrument transformers. The main functions and advantages of instrument transformers are as follows:

1. Instrument transformers are used to reduce high voltages and currents to useable values for measuring and protection purposes.
2. Measuring and protection equipments need not be insulated for high voltages.
3. Working at reduced values of currents and voltages is safer.
4. Simple and reliable protection and measuring circuitry.
5. Reduction in currents and/or voltages leads to lesser insulation requirement and current capacities of conductors.
6. With the use of instrument transformers the protection and measuring systems become compact and economical.

Following important considerations are to be taken into account for proper application of instrument transformers.

- Ratio in terms of primary and secondary voltages or currents (that is input to output ratio)

Q. 2. Explain the working of balanced beam relay.

Ans.

The balanced beam relay operates on the balance principle by comparing two quantities, for example, two currents or one current and

one voltage. Fig. 2.2 shows an electromagnetic attraction *balanced-beam type* relay. It is the general form of the relay comparing two currents. The beam (armature) is attracted by the electromagnets which are operated by the appropriate parameters, usually two currents or one current and one voltage.

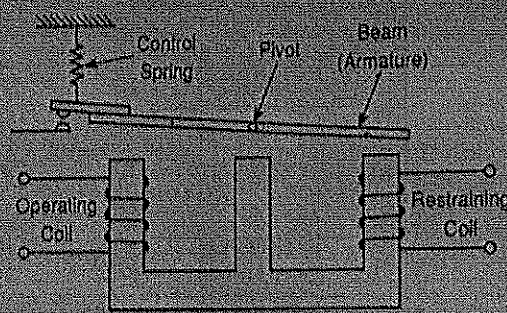

Fig. 2.2 Balanced beam relay

The beam is given a slight mechanical bias to keep the contacts open, except when operation is required. This is achieved by a control spring or weight adjustment. Suppose that the two coils have equal number of turns. The relay will operate when

$$I_o^2 = I_r^2 + K$$

where, I_o = current in the operating coil

I_r = current in the restraining coil

K = a constant

Q. 3. Derive the expression for the relationship between Line voltage and Phase voltage for a "delta" connected system and comment about straight rating.

Ans.

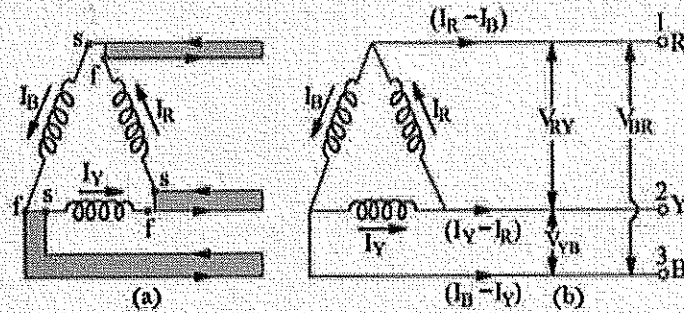

- Current in Line 1 = $I_1 = I_R - I_B$
- Current in Line 2 = $I_2 = I_Y - I_R$
- Current in Line 3 = $I_3 = I_B - I_Y$

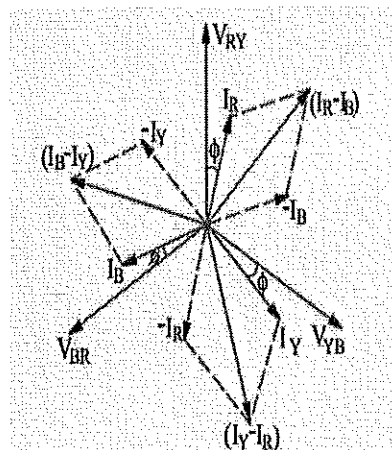

The current of Line 1 can be found by determining the vector difference between I_R and I_B and we can do that by increasing the I_B Vector in reverse, so that, I_R and I_B makes a parallelogram. The diagonal of that parallelogram shows the vector difference of I_R and I_B which is equal to current in Line 1 = I_1 . Moreover, by reversing the vector of I_B , it may indicate as $(-I_B)$, therefore, the angle between I_R and $-I_B$ (I_B , when reversed = $-I_B$) is 60° . If,

$I_R = I_Y = I_B = I_{PH} \dots$ The phase currents

Then;

The current flowing in Line 1 would be;

$$I_L \text{ or } I_1 = 2 \times I_{PH} \times \cos(60^\circ/2)$$

$$= 2 \times I_{PH} \times \cos 30^\circ$$

$$= 2 \times I_{PH} \times (\sqrt{3}/2) \dots \dots \text{ Since } \cos 30^\circ = \sqrt{3}/2$$

$$I_L = \sqrt{3} I_{PH}$$

i.e. In Delta Connection, The Line current is $\sqrt{3}$ times of Phase Current.

Q. 4. What are different types of faults?

Ans.

Symmetrical Faults

In such type of faults all the three phases are short circuited to each other. There may be two situations. In one case, all the three phases are short-circuited to the ground. This type of fault is called *three-phase to ground (LLLG) fault*. In the other case, all the three phases are short-circuited without involving the ground. This type of fault is called *three phase short-circuit (LLL) fault*. Faults of the type LLL and LLLG are balanced and symmetrical in the sense that the system remains symmetrical, that is, balanced even after the fault. A three-phase short circuit occurs rarely, but it is the most severe type of fault involving largest currents. For this reason, the balanced short-circuit calculations are performed to determine these large currents to be used to determine the rating of circuit breakers.

Unsymmetrical Faults

The term unsymmetrical fault is used to mean unbalanced conditions. It is a connection or situation which causes an unbalance among the three phases.

An unsymmetrical *short fault* is an imbalance between phases or between phase and ground. A *series fault* is an imbalance in the line impedances. It does not involve any connection between lines, or between line and ground at fault point.

Short faults in a three-phase system can be classified as follows:

1. Single line-to-ground (LG) fault
2. Line to line (LL) fault
3. Double line-to-ground (LLG) fault
4. Three-phase short circuit (LLL) fault
5. Three-phase to ground (LLLG) fault

A *single-line-to-ground (LG)* fault occurs when one phase conductor breaks and falls to ground or when one phase conductor comes in contact with neutral conductor.

A *line to line (LL)* fault occurs when two phase conductors are short circuited.

A *double line-to-ground (LLG)* fault occurs when two conductors fall and connected through ground, or when two conductors come in contact with the neutral of a three-phase grounded system.

Open Conductor Faults

A break in one or two phase conductors in a 3-phase circuit leads to an open-conductor fault. Such faults may also be caused when circuit breakers or isolators open but fail to close one or more phases. Unbalanced currents flow in the system due to opening of one or two phases. This results in overheating of rotating machines.

All these types of faults may occur in the alternators, motors or transformers, or any part of the power system.

Two or more faults may occur simultaneously on a system. Such faults are known as *multiple or simultaneous faults*. In such faults, the same or different types of faults may take place at the same or different points of the system.

Q. 5. What are ratio and phase angle error in CTs? Give causes and remedies for them.

Ans.

The CTs usually used for protection purposes are different from CTs used only for measuring purposes. CTs used in measuring purposes require accuracy over the normal working range of the system currents. CTs used for protection purposes need to be accurate for upto several times the normal system current (primary current). Current transformers used for protection usually have a secondary circuit rating of 5A or 1A.

Any abnormal increase in primary current due to some fault saturates the core. Increase in the burden (above VA capacity) of the CT can also cause such a condition.

Deviation of actual current ratio from nominal current ratio is observed as the CT core enters saturation. This is known as ratio error and is defined as follows.

$$\text{Ratio Error} = \frac{\text{nominal ratio} - \text{actual ratio}}{\text{actual ratio}}$$

$$N = \frac{I_p}{I_s}$$

$$= \frac{N_s - I_p}{I_p}$$

Protection Systems

Where, N = nominal ratio = $\frac{\text{rated primary current}}{\text{rated secondary current}}$

I_p = actual primary current

I_s = actual secondary current

Deviation in phase angle of the reversed secondary current phasor with primary current phasor is also observed. This is called phase angle error.

Usually the ratio error is largely dependent on wattful component of the exciting current and the phase angle error depends on the magnetizing component of the exciting current. Phase angle errors are not of much concern in case of CTs. Usually lower power factor loads (relay coils) are connected which compensate the phase angle errors. Phase angle errors can be tolerated in protective relaying.

Q. 6. What is meant by an Electric Hazard? What are the types of Electric Hazards?

Ans. "Electrical hazards" is taken to mean events of an electrical nature that pose a hazard to people. The essential ones to list here are electric shock and arcing faults. NFPA 79, requires electrical equipment to protect people from the following hazards:

Electric shock due to direct or indirect contact

Arc flashing

Q. 7. Find the values of current in each loop of the bellow circuit.

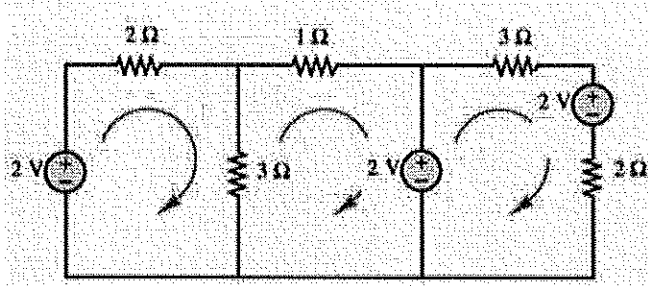

Ans.

For loop 1

$$2 - 2(I_1) - 3(I_1 - I_3) = 0 \dots\dots\dots(1)$$

For loop 2

$$-3(I_2 - I_1) - 1(I_2) - 2 = 0 \dots\dots\dots(2)$$

For loop 3

$$2 - 3(I_3) - 2 - 2(I_3) = 0 \dots\dots\dots(3)$$

By solving the equation (1) become

$$5I_1 - 3I_2 = 2 \dots\dots\dots(4)$$

By solving the equation (2) become

$$3I_1 - 4I_2 = 2 \dots\dots\dots(5)$$

By solving the equation (3) become

$$I_3 = 0$$

By solving the equation (4 & 5) become

$$I_2 = -4/11$$

$$I_1 = 34/11$$

Q. 8. What are the advantages of induction cup type relay over induction disc type relay?

Ans.

The induction cup type relay has several advantages over the induction disc type relay.

1. Since the rotating parts of the induction cup relay are of low inertia, it is capable of high-speed rotation. Therefore, it can be used for function requiring instantaneous operation. The operation time is less than 0.01 second.
2. It has high sensitivity and minimum magnetic leakage.
3. It has the ability to operate on low voltages.
4. There is no current or voltage creep. That is, if there is no voltage or current, the rotor does not move.
5. It can be made to have linear operating characteristics and a very high ratio of resetting to operating values.
6. This type of relay is best suited where normal and abnormal conditions are very close together.
7. These relays impose less burden on the main circuits.
8. Transient effects can be minimized with proper designs.

The multiplicity of poles permits the measurement of more than one electrical quantity. Different combinations of input quantities can be used for different applications, system voltages or currents, or network voltages.

Induction cup relays are most suitable for distance and directional relays.

Q. 1. Draw the voltage, current and power waveforms of following circuit. Also, comment on the average power.

- R Circuit
- RL Circuit when $R > L$
- RL Circuit when $R < L$
- RC circuit when $R > C$
- RC circuit when $R < C$

Ans.

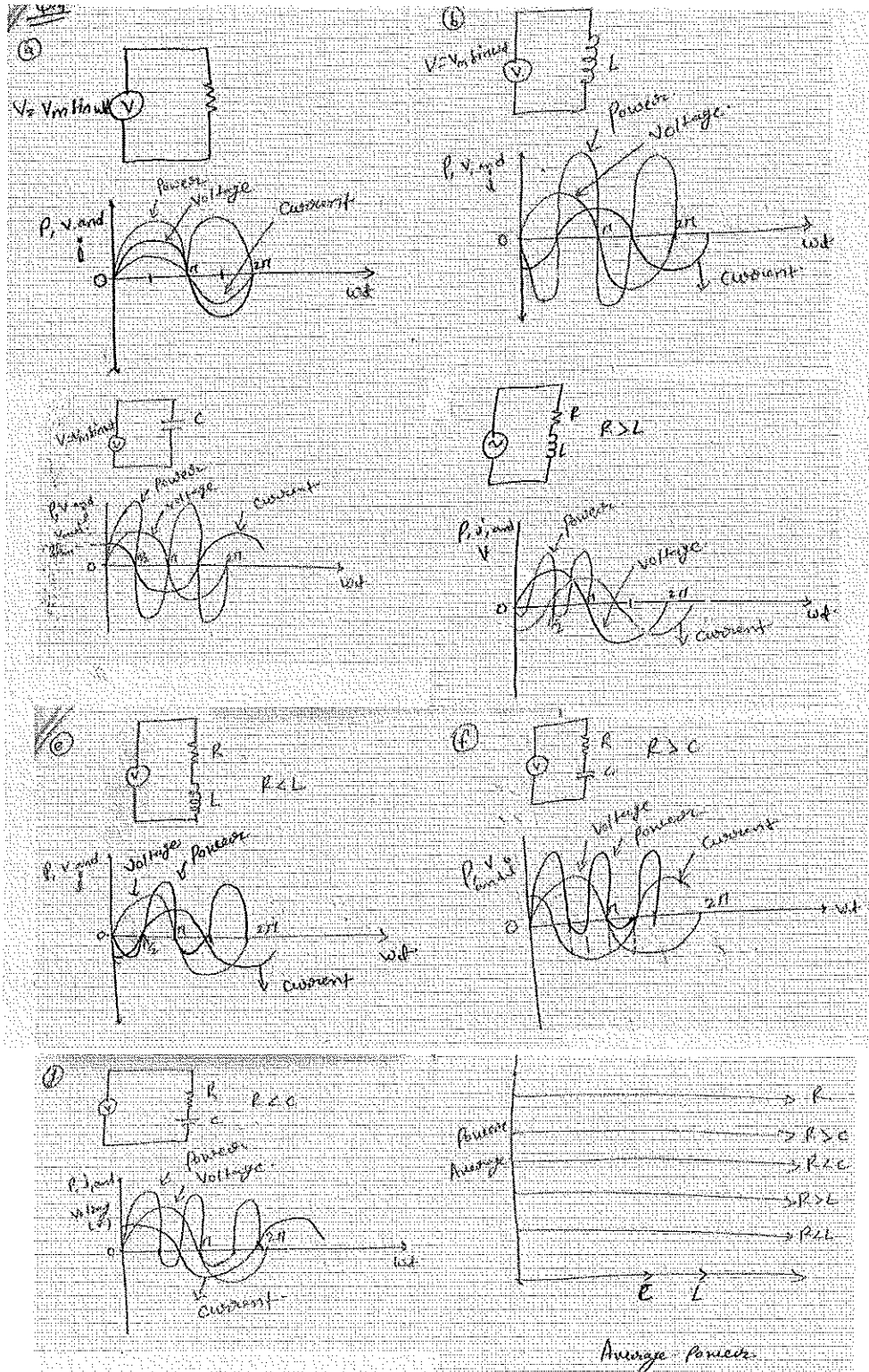

Q. 2. Write a short note on feeder circuit and branch circuit with the help of a suitable diagram.

Ans.

- Feeder circuit: All conductors between the incoming supply and the branch circuit protective device.
- Branch circuit: The circuit conductors between the branch circuit protective device and the outlets.
- Feeder circuit: The conductors and circuitry on the supply side of the branch circuit protective device.
- Branch circuit: The conductors and components following the last branch circuit protective device protecting a load.

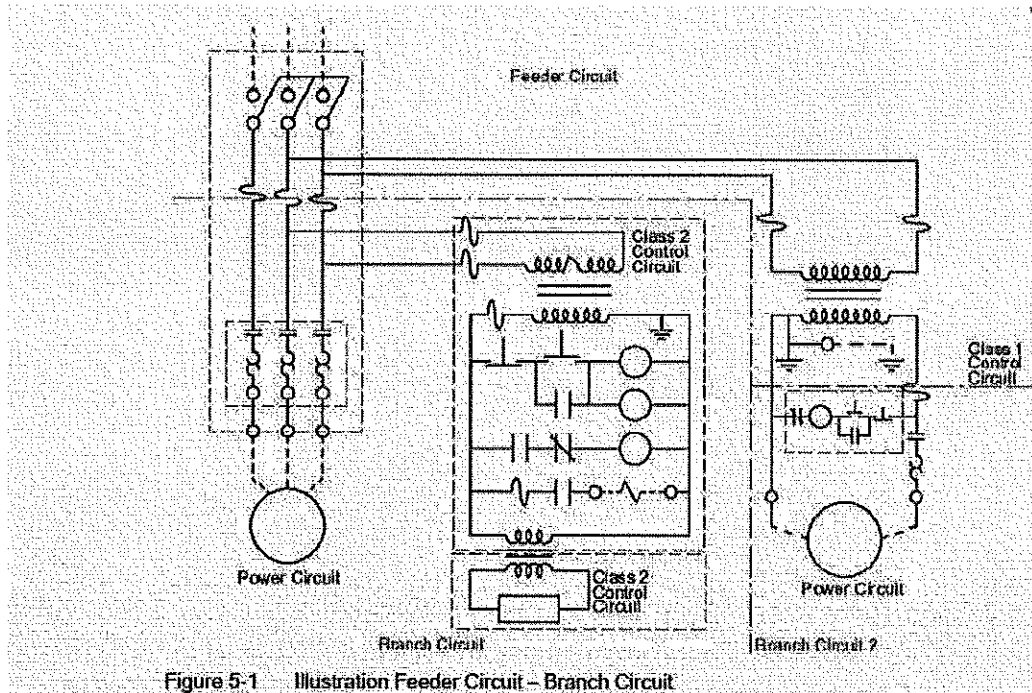

Q. 3. Explain how the rotating magnetic field is created in 3 phase induction machine.

Ans.

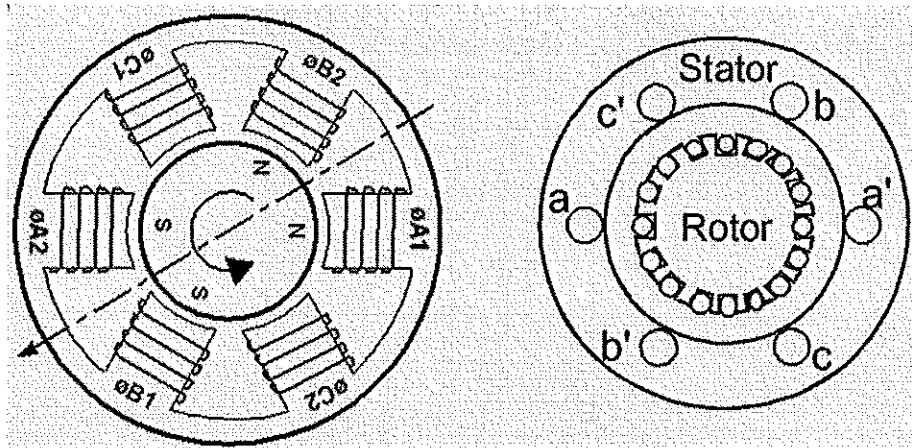

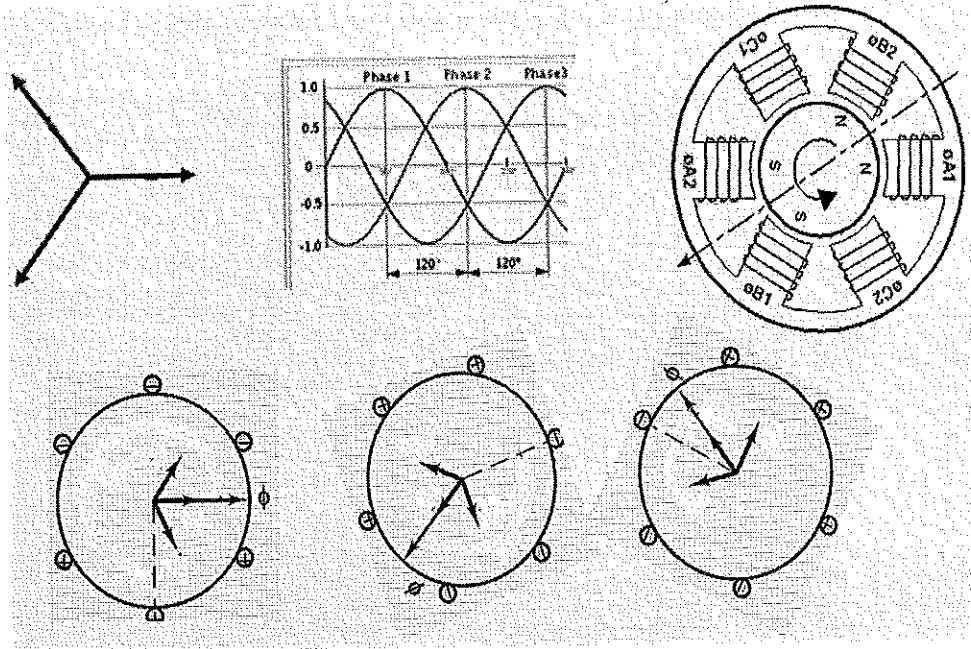

Q. 4. A 4 pole 50Hz Induction machine calculate the rotor frequency in following condition:

- At stand still
- Motor is running at 500 rpm in same direction of field

Ans.

➤ A 4 pole 50Hz IM

Calculate the rotor frequency in following condition

➤ At stand still

$$N_s = \frac{120f}{P}$$

$$= \frac{120 \times 50}{4} = 1500 \text{ rpm}$$

At stand still $N_r = 0$

$$S = \frac{N_s - N_r}{N_s}$$

$$S = \frac{1500 - 0}{1500} \quad S = 1$$

Rotor frequency $f_r = s * f_s = 1 * 50 = 50 \text{ Hz}$

➤ A 4 pole 50Hz IM

Calculate the rotor frequency in following condition

➤ Motor is running at 500 rpm in same direction of field

$$N_s = \frac{120f}{P}$$

$$= \frac{120 \times 50}{4} = 1500 \text{ rpm}$$

Here, $N_r = 500$

$$S = \frac{N_s - N_r}{N_s}$$

$$S = \frac{1500 - 1000}{1500} \quad S = 0.04$$

Rotor frequency $f_r = s * f_s = 0.04 * 50 = 2 \text{ Hz}$

Q. 5. Derive the expression for torque produced by an induction relay.

Ans.

2.4 THEORY OF INDUCTION RELAY TORQUE

Let ϕ_1 and ϕ_2 be the sinusoidal fluxes produced in the induction relays. If θ is the phase angle between them

$$\phi_1 = \phi_{1m} \sin \omega t$$

$$\phi_2 = \phi_{2m} \sin (\omega t + \theta)$$

The flux ϕ_2 leads ϕ_1 by θ .

In case of shaded-pole construction ϕ_1 is produced by the shaded pole and ϕ_2 by the unshaded pole. In wattmeter type construction ϕ_1 is produced by the upper electromagnet and ϕ_2 by the lower electromagnet. In cup-type construction ϕ_1 and ϕ_2 are produced by pair of coils. The theory of torque production given below is valid for both the disc type and cup type induction relays.

The two fluxes ϕ_1 and ϕ_2 will induce voltages in the rotor. The voltages induced in the rotor are given by

$$e_1 = \frac{d\phi_1}{dt}$$

$$= \frac{d}{dt} [\phi_{1m} \sin \omega t]$$

$$= \phi_{1m} \omega \cos \omega t$$

$$e_2 = \frac{d\phi_2}{dt}$$

$$= \frac{d}{dt} [\phi_{2m} \sin (\omega t + \theta)]$$

$$= \phi_{2m} \omega \cos (\omega t + \theta)$$

These voltages will circulate eddy currents in the rotor. If the rotor is assumed to be noninductive, these currents will be in phase with their respective voltages. Assuming same resistance to the flow of eddy currents

$$i_1 \propto e_1$$

$$i_2 \propto e_2$$

$$i_1 = \phi_{1m} \cos \omega t$$

$$i_2 = \phi_{2m} \cos (\omega t + \theta)$$

The flux ϕ_1 will interact with eddy current i_2 and ϕ_2 will interact with i_1 . Since ϕ_2 is leading ϕ_1 , the torque due to ϕ_2 and i_1 will be taken as positive and the torque due to ϕ_1 and i_2 will be negative.

The resultant torque is

$$T \propto \phi_2 i_1 - \phi_1 i_2$$

$$\phi_2 i_1 - \phi_1 i_2 = [\phi_{2m} \sin (\omega t + \theta)] [\phi_{1m} \cos \omega t]$$

$$- [\phi_{1m} \sin \omega t] [\phi_{2m} \cos (\omega t + \theta)]$$

$$= \phi_{1m} \phi_{2m} \sin \theta$$

$$T \propto \phi_{1m} \phi_{2m} \sin \theta$$



Registration No. _____

BHARTIYA SKILL DEVELOPMENT UNIVERSITY
School of Electrical Skills
Third Semester, End Semester Examination
B. Voc. Program, Winter Semester, (Session: 2018-19)

Course Code: ELE 1302
Course Name: Electrical Design Developer

Time: 3 Hours
Max. Marks: 100

Instructions: Answer all questions from section A, each question carries two marks. Answer any six questions from section B, each question carries five marks. Answer all questions from section C, each question carries ten marks. Scientific calculator can be used.

Section – A

10x2=20 Marks

- Q.1. (A) The frame of an induction motor is usually made of:
(a) Silicon Steel (b) Cast Iron (c) Aluminium (d) Bronze
- (B) The shaft of an induction motor is made of:
(a) Stainless steel (b) Carbon steel (c) Cast iron (d) Aluminium
- Q.2. (A) In an induction motor, the slip at no-load is:
(a) < 1% (b) 2% (c) 4% (d) 5%
- (B) The starting torque of a squirrel-cage induction motor is:
(a) Full-load torque (b) Slightly more than full-load torque
(c) Low (d) Negligible
- Q.3. (A) The term cogging is associated with:
(a) Three phase transformer (b) Generator (c) DC Motor (d) Induction Motor
- (B) What is the total installed capacity of capacitor banks in BSDU?
(a) 100kVAR (b) 300 kVAR (c) 400 kVAR (d) 450kVAR
- Q.4. (A) If the two phases of an induction motor are interchanged:
(a) Motor will run in reverse direction (b) Motor will run in same direction
(c) Motor will stop (d) Motor will burn
- (B) In case of a three-phase squirrel-cage induction motors:
(a) Rotor conductors are kept open
(b) Rotor conductor ends are short-circuited through slip rings
(c) Rotor conductors are short-circuited through end rings
(d) Rotor conductors are connected to insulation
- Q.5. (A) The field of an induction stator rotates at:
(a) Rotor speed (b) Synchronous speed (c) Slip speed (d) Very low speed
- (B) The relation between rotor frequency f_2 slip s , and stator frequency f_1 is given by:
(a) $f_2 = f_1/s$ (b) $f_2 = sf_1$ (c) $f_2 = (1-s)f_1$ (d) None of these
- Q.6. (A) Three-phase alternators are invariably Y-connected because:
(a) Magnetic losses are minimised (b) Less turns of wire are required
(c) Smaller conductors can be used (d) Higher terminal voltage is obtained
- (B) What does the data 950V/1030 A given on the name plate of induction motor represent?
(a) 950V: The lowest stator voltage
(b) 950V: The voltage across two short circuited sliprings
(c) 950V: The voltage across two sliprings when motor is stationary
(d) 1030A: Current drawn from the circuit at rated load
- Q.7. (A) What kind of rotor is most suitable for turbo-alternators which are designed to run at high speed?
(a) Salient pole type (b) Non-salient pole type
(c) Inversely proportional to its upper 3dB frequency (d) None of the above
- (B) Which of the following is a prime mover?
(a) Steam Turbine (b) Solar Energy (c) Electric Heater (d) None of the above

- Q.8. (A) Which of the following is not a part of transformer installation?
 (a) Conservator (b) Breather (c) Buchholz Relay (d) Exciter
- (B) In an alternator one of the advantages of distributing the winding is to:
 (a) Improve voltage waveform (b) Reduce Noise
 (c) Reduce Harmonics (d) None
- Q.9. (A) The power factor of an alternator depends upon:
 (a) Speed (b) Conductor (c) Load (d) All of these
- (B) Class B insulation can withstand a maximum temperature of:
 (a) 120°C (b) 130°C (c) 105°C (d) 135°C
- Q.10. (A) Why there is an enamel layer coated over the laminations of the transformer core?
 (a) To decrease the hum (b) To attain adhesion between laminations
 (c) To insulate the laminations against each other (d) To prevent the corrosion of the laminations
- (B) Which type of circuit breaker is used in BSDU control panel?
 (a) Oil circuit breaker (b) SF₆ circuit breaker (c) Air circuit breaker (d) All of these

Section – B

6x5=30 Marks

Answer any six questions.

- Q. 1. What are the important factors to be considered in designing the field of an alternator?
- Q. 2. Define coil side, pole pitch and slot angle of an alternator.
- Q. 3. What are the different types of losses in a three phase induction motor?
- Q. 4. What are the types of windings used in an alternator? Give comparison between lap and wave windings by neat sketch
- Q. 5. An 8-pole, 3-phase, 60 Hz, star connected induction motor has a slip of 5%. Calculate full load speed of motor.
- Q. 6. Derive the EMF equation of an alternator.
- Q. 7. A 208-V, 10hp, four pole, 60 Hz, Y-connected induction motor has a full-load slip of 5 percent. Calculate rotor speed and rotor frequency at rated load.
- Q. 8. Derive the expression for per unit current and per unit impedance.

Section – C

5x10=50 Marks

- Q. 1. Explain with neat sketch the purpose of damper windings used in an alternator and derive the resultant emf for short pitched coil of an alternator considering phasor diagram.
- Q. 2. What is the purpose of single line diagram? Explain each component with the help of neat sketch.
- Q. 3. Given: A 5 KVA, 500/250V, 50Hz, single phase transformer:
 (a) OC Test: 500V, 1A, 50W (LV side open)
 (b) SC Test: 25V, 10A, 60W (LV side shorted)
 Determine the efficiency on full load 0.8 lagging power factor.
- Q. 4. What are the different windings used in transformer? Explain all in detail with neat sketches.
- Q. 5. Explain the torque slip characteristics of three phase induction motor.



Registration No. _____

BHARTIYA SKILL DEVELOPMENT UNIVERSITY
School of Electrical Skills
Third Semester, End Semester Examination
B. Voc. Program, Winter Semester, (Session: 2018-19)

Course Code: ELE 1302
Course Name: Electrical Design Developer

Time: 3 Hours
Max. Marks: 100

Instructions: Answer all questions from section A, each question carries two marks. Answer any six questions from section B, each question carries five marks. Answer all questions from section C, each question carries ten marks. Scientific calculator can be used.

Section – A

10x2=20 Marks

- Q.1. (A) The frame of an induction motor is usually made of:
(a) Silicon Steel (b) Cast Iron (c) Aluminium (d) Bronze
- (B) The shaft of an induction motor is made of:
(a) Stainless steel (b) Carbon steel (c) Cast iron (d) Aluminium
- Q.2. (A) In an induction motor, the slip at no-load is:
(a) < 1% (b) 2% (c) 4% (d) 5%
- (B) The starting torque of a squirrel-cage induction motor is:
(a) Full-load torque (b) Slightly more than full-load torque
(c) Low (d) Negligible
- Q.3. (A) The term cogging is associated with:
(a) Three phase transformer (b) Generator (c) DC Motor (d) Induction Motor
- (B) What is the total installed capacity of capacitor banks in BSDU?
(a) 100kVAR (b) 300 kVAR (c) 400 kVAR (d) 450kVAR
- Q.4. (A) If the two phases of an induction motor are interchanged:
(a) Motor will run in reverse direction (b) Motor will run in same direction
(c) Motor will stop (d) Motor will burn
- (B) In case of a three-phase squirrel-cage induction motors:
(a) Rotor conductors are kept open
(b) Rotor conductor ends are short-circuited through slip rings
(c) Rotor conductors are short-circuited through end rings
(d) Rotor conductors are connected to insulation
- Q.5. (A) The field of an induction stator rotates at:
(a) Rotor speed (b) Synchronous speed (c) Slip speed (d) Very low speed
- (B) The relation between rotor frequency f_2 slip s , and stator frequency f_1 is given by:
(a) $f_2 = f_1/s$ (b) $f_2 = sf_1$ (c) $f_2 = (1-s)f_1$ (d) None of these
- Q.6. (A) Three-phase alternators are invariably Y-connected because:
(a) Magnetic losses are minimised (b) Less turns of wire are required
(c) Smaller conductors can be used (d) Higher terminal voltage is obtained
- (B) What does the data 950V/1030 A given on the name plate of induction motor represent?
(a) 950V: The lowest stator voltage
(b) 950V: The voltage across two short circuited sliprings
(c) 950V: The voltage across two sliprings when motor is stationary
(d) 1030A: Current drawn from the circuit at rated load
- Q.7. (A) What kind of rotor is most suitable for turbo-alternators which are designed to run at high speed?
(a) Salient pole type (b) Non-salient pole type
(c) Inversely proportional to its upper 3dB frequency (d) None of the above
- (B) Which of the following is a prime mover?
(a) Steam Turbine (b) Solar Energy (c) Electric Heater (d) None of the above

- Q.8. (A) Which of the following is not a part of transformer installation?
 (a) Conservator (b) Breather (c) Buchholz Relay (d) Exciter
- (B) In an alternator one of the advantages of distributing the winding is to:
 (a) Improve voltage waveform (b) Reduce Noise
 (c) Reduce Harmonics (d) None
- Q.9. (A) The power factor of an alternator depends upon:
 (a) Speed (b) Conductor (c) Load (d) All of these
- (B) Class B insulation can withstand a maximum temperature of:
 (a) 120°C (b) 130°C (c) 105°C (d) 135°C
- Q.10. (A) Why there is an enamel layer coated over the laminations of the transformer core?
 (a) To decrease the hum (b) To attain adhesion between laminations
 (c) To insulate the laminations against each other (d) To prevent the corrosion of the laminations
- (B) Which type of circuit breaker is used in BSDU control panel?
 (a) Oil circuit breaker (b) SF₆ circuit breaker (c) Air circuit breaker (d) All of these

Section – B

6x5=30 Marks

Answer any six questions.

- Q. 1. What are the important factors to be considered in designing the field of an alternator?
- Q. 2. Define coil side, pole pitch and slot angle of an alternator.
- Q. 3. What are the different types of losses in a three phase induction motor?
- Q. 4. What are the types of windings used in an alternator? Give comparison between lap and wave windings by neat sketch
- Q. 5. An 8-pole, 3-phase, 60 Hz, star connected induction motor has a slip of 5%. Calculate full load speed of motor.
- Q. 6. Derive the EMF equation of an alternator.
- Q. 7. A 208-V, 10hp, four pole, 60 Hz, Y-connected induction motor has a full-load slip of 5 percent. Calculate rotor speed and rotor frequency at rated load.
- Q. 8. Derive the expression for per unit current and per unit impedance.

Section – C

5x10=50 Marks

- Q. 1. Explain with neat sketch the purpose of damper windings used in an alternator and derive the resultant emf for short pitched coil of an alternator considering phasor diagram.
- Q. 2. What is the purpose of single line diagram? Explain each component with the help of neat sketch.
- Q. 3. Given: A 5 KVA, 500/250V, 50Hz, single phase transformer:
 (a) OC Test: 500V, 1A, 50W (LV side open)
 (b) SC Test: 25V, 10A, 60W (LV side shorted)
 Determine the efficiency on full load 0.8 lagging power factor.
- Q. 4. What are the different windings used in transformer? Explain all in detail with neat sketches.
- Q. 5. Explain the torque slip characteristics of three phase induction motor.



Answer Key
Registration No. _____

BHARTIYA SKILL DEVELOPMENT UNIVERSITY
School of Electrical Skills
Third Semester, End Semester Examination
B. Voc. Program, Winter Semester, (Session: 2018-19)

Course Code: ELE 1302
Course Name: Electrical Design Developer

Time: 3 Hours
Max. Marks: 100

Instructions: Answer all questions from section A, each question carries two marks. Answer any six questions from section B, each question carries five marks. Answer all questions from section C, each question carries ten marks. Scientific calculator can be used.

Section – A

10x2=20 Marks

- Q.1. (A) The frame of an induction motor is usually made of:
(a) Silicon Steel (b) Cast Iron (c) Aluminium (d) Bronze
Ans. (b)
- (B) The shaft of an induction motor is made of:
(a) Stainless steel (b) Carbon steel (c) Cast iron (d) Aluminium
Ans. (b)
- Q.2. (A) In an induction motor, no-load the slip is generally:
(a) < 1% (b) 2% (c) 4% (d) 5%
Ans. (a)
- (B) The starting torque of a squirrel-cage induction motor is:
(a) Full-load torque (b) Slightly more than full-load torque
(c) Low (d) Negligible
Ans. (c)
- Q.3. (A) The term cogging is associated with:
(a) Three phase transformer (b) Generator (c) DC Motor (d) Induction Motor
Ans. (d)
- (B) What is the total installed capacity of capacitor banks in BSDU?
(a) 100kVAr (b) 300 kVAr (c) 400 kVAr (d) 450kVAr
Ans. (d)
- Q.4. (A) If the two phases of an induction motor are interchanged:
(a) Motor will run in reverse direction (b) Motor will run in same direction
(c) Motor will stop (d) Motor will burn
Ans. (a)
- (B) In three-phase squirrel-cage induction motors:
(a) Rotor conductors are kept open
(b) Rotor conductor ends are short-circuited through slip rings
(c) Rotor conductors are short-circuited through end rings
(d) Rotor conductors are connected to insulation
Ans. (b)
- Q.5. (A) The field of an induction motor rotor rotates relative to the stator at:
(a) Rotor speed (b) Synchronous speed (c) Slip speed (d) Very low speed
Ans. (b)
- (B) The relation between rotor frequency f_2 slip s , and stator frequency f_1 is given by:
(a) $f_2 = f_1/s$ (b) $f_2 = sf_1$ (c) $f_2 = (1-s)f_1$ (d) None of these
Ans. (a)
- Q.6. (A) Three-phase alternators are invariably Y-connected because:
(a) Magnetic losses are minimised (b) Less turns of wire are required
(c) Smaller conductors can be used (d) Higher terminal voltage is obtained
Ans. (b)
- (B) What does the data 950V/1030 A given on the name plate of induction motor represent?
(a) 950V: The lowest stator voltage
(b) 950V: The voltage across two short circuited sliprings
(c) 950V: The voltage across two sliprings when motor is stationary
(d) 1030A: Current drawn from the circuit at rated load
Ans. (b)

- Q.7. (A) What kind of rotor is most suitable for turbo-alternators which are designed to run at high speed?
 (a) Salient pole type (b) Non-salient pole type
 (c) Inversely proportional to its upper 3dB frequency (d) None of the above

Ans. (b)

- (B) Which of the following is a prime mover?
 (a) Steam Turbine (b) Solar Energy (c) Electric Heater (d) None of the above

Ans. (a)

- Q.8. (A) Which of the following is not a part of transformer installation?
 (a) Conservator (b) Breather (c) Buchholz Relay (d) Exciter

Ans. (d)

- (B) In an alternator one of the advantages of distributing the winding is to:

- (a) Improve voltage waveform (b) Reduce Noise
 (c) Reduce Harmonics (d) None

Ans. (a)

- Q.9. (A) The power factor of an alternator depends upon:
 (a) Speed (b) Conductor (c) Load (d) All of these

Ans. (c)

- (B) Class B insulation can withstand a maximum temperature of:
 (a) 120° C (b) 130° C (c) 105° C (d) 135° C

Ans. (b)

- Q.10. (A) Why there is an enamel layer coated over the laminations of the transformer core?
 (a) To decrease the hum (b) To attain adhesion between laminations
 (c) To insulate the laminations against each other (d) To prevent the corrosion of the laminations

Ans. (c)

- (B) Which type of circuit breaker is used in BSDU control panel?
 (a) Oil circuit breaker (b) SF₆ circuit breaker (c) Air circuit breaker (d) All of these

Ans. (c)

Section – B

6x5=30 Marks

Answer any six questions.

- Q. 1. What are the factors helpful in designing the field of an alternator?

- Ans. 1. Number of poles and voltage across each field winding
 2. Amp-turn per pole
 3. Copper loss in the field coil
 4. Dissipating surface of field coil
 5. Specific loss dissipation and allowable temperature rise.

- Q. 2. Define coil side, pole pitch and slot angle of an alternator.

Ans. Coil Side: Coil consists of many turns. Part of the coil in each slot is called coil side of a coil as shown in the above figure.

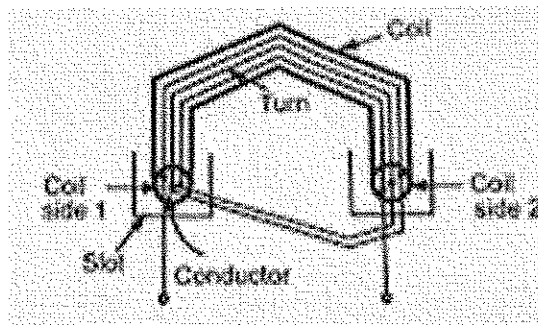

Fig1: Coil sides

Pole Pitch: It is centre to centre distance between the two adjacent poles. We have seen that for one rotation of the conductors, 2 poles are responsible for 360° electrical of emf., 4 poles are responsible for 720° electrical of emf and so on. so 1 pole is responsible for 180° electrical of induced emf.

Slot angle (β): The phase difference contributed by one slot in degrees electrical is called slot angle As slots per pole contributes 180° electrical which is denoted as 'n'

Q. 3. What are the different types of losses in a three phase induction motor?

Ans. The input power given to an Induction motor is in the form of three-phase voltage and currents. The Power Flow Diagram of an Induction Motor is shown below.

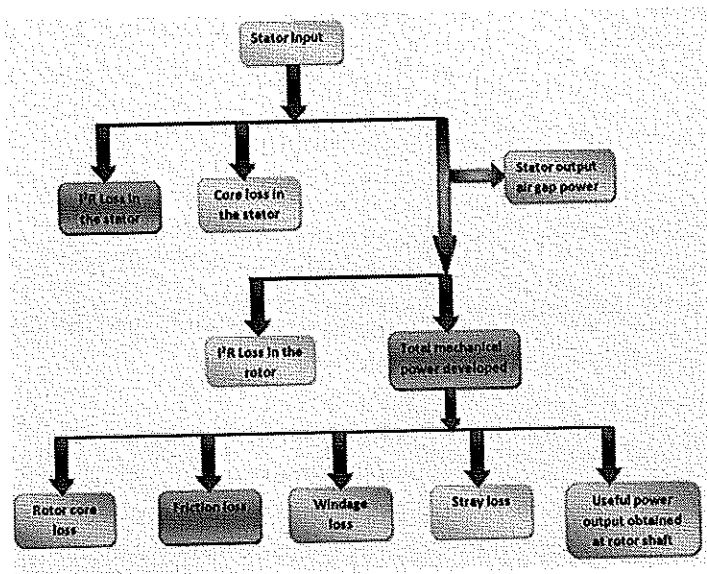

Q. 4. What are the types of windings used in an alternator? Give comparison between lap and wave windings by neat sketch.

Ans. Types of winding used in an alternator

- Single phase and poly phase armature winding.
- Concentrated winding and distributed winding.
- Half coiled and whole coiled winding.
- Single layer and double layer winding.
- Lap, wave and concentric or spiral winding and
- Full pitched coil winding and fractional pitched coil winding.

Basis For Comparison	Lap Winding	Wave Winding
Definition	The coil is lap back to the succeeding coil.	The coil of the winding form the wave shape.
Connection	The end of the armature coil is connected to an adjacent segment on the commutators.	The end of the armature coil is connected to commutator segments some distance apart.
Parallel Path	The numbers of parallel path are equal to the total of number poles.	The number of parallel paths is equal to two.
Other Name	Parallel Winding or Multiple Winding	Two-circuit or Series Winding.
EMF	Less	More
Number of Brushes	Equal to the number of parallel paths.	Two
Types	Simplex and Duplex lap winding.	Progressive and Retrogressive wave winding
Efficiency	Less	High

Q. 5. An 8-pole, 3-phase, 60 Hz, star connected induction motor has a slip of 5%. Calculate full load speed of motor.

Ans. In Induction Motor,

Speed $N_s = (120 * \text{frequency}) / (\text{No. of poles})$

Speed $N_s = (120 * 60) / 8 = 900 \text{ rpm.}$

So the slip $S = (N_s - N) / N_s$

$0.05 = (900 - N) / 900$

$N = 855 \text{ rpm}$

Q. 6. Derive the EMF equation of an alternator.

Ans.

Let $Z = \text{No. of conductors or coil sides in series per phase}$

$\Phi = \text{Flux per pole in webers}$

$P = \text{Number of rotor poles}$

$N = \text{Rotor speed in r.p.m}$

In one revolution (i.e., $60/N$ second), each stator conductor is cut by $P\Phi$ webers, i.e.,

$$d\Phi = P\Phi; dt = 60/N$$

\therefore Average e.m.f. induced in one stator conductor

$$= \frac{d\Phi}{dt} = \frac{P\Phi}{60/N} = \frac{P\Phi N}{60} \text{ volts}$$

Since there are Z conductors in series per phase,

$$\therefore \text{Average e.m.f. per phase} = \frac{P\Phi N}{60} \times Z$$

$$= \frac{P\Phi N}{60} \times \frac{120f}{P}$$

$$= 2f\Phi Z \text{ volts} \quad \left(N = \frac{120f}{P} \right)$$

R.M.S value of e.m.f./ phase = Average value/ phase \times form factor

$$= 2f\Phi Z \times 1.11 = 2.22 f\Phi Z$$

$$E_{\text{rms}} / \text{phase} = 2.22 f\Phi Z \text{ volts.}$$

Q. 7. A 208-V, 10hp, four pole, 60 Hz, Y-connected induction motor has a full-load slip of 5 percent. Calculate rotor speed and rotor frequency at rated load.

Ans. Speed $N_s = (120 * \text{frequency}) / (\text{No. of poles})$

Speed $N_s = (120 * 60) / 4 = 180 \text{ rpm}$

So the slip $S = (N_s - N) / N_s$

$(1 - 0.05) * 1800 = 1710 \text{ rpm.}$

$f_r = s f_s$

$f_r = 0.05 * 60 = 3 \text{ Hz.}$

Q. 8. Derive the formula for per unit current and per unit impedance.

Ans. The per unit value of any quantity is defined as the ratio of actual value in any unit and the base or reference value in the same unit.

Any quantity is converted into per unit quantity by dividing the numeral value by the chosen base value of the same dimension.

The per unit value are dimensionless.

Base voltage = reference voltage of the machine

Base current = reference current of the machine

Base impedance = base voltage /base current

Base power = base voltage x base current

$$\text{Per Unit Value} = \frac{\text{Actual value in any unit}}{\text{Base or reference value in the same unit}}$$

$$Z_B = \frac{V_B}{I_B} \quad \text{Per Unit KV} = \frac{\text{Actual KV}}{\text{Base KV}} = \frac{KV_{\text{actual}}}{KV_B}$$

$$\text{Base current } I_B = \frac{\text{Base KVA}}{\text{Base KV}} = \frac{KVA_B}{KV_B} \dots \dots \dots (1)$$

$$\text{Per unit current } I_{pu} = \frac{\text{Actual value of current}}{\text{Base current}} \dots \dots \dots (2)$$

Putting the value of base current from the equation (1) in equation (2) we get

$$\text{Per unit current } I_{pu} = \frac{\text{Actual value of current}}{KVA_B / KV_B}$$

$$\text{Per unit current } I_{pu} = \frac{\text{Actual value of current} \times KV_B}{KVA_B}$$

$$\text{Base impedance } Z_B = \frac{\text{Base KV} \times 1000}{\text{Base current}} \dots \dots \dots (3)$$

Putting the value of base current from the equation (1) in the equation (3) we get

$$\text{Base impedance } Z_B = \frac{KV_B \times 1000}{KVA_B / KV_B}$$

$$\text{Base impedance } Z_B = \frac{(KV_B)^2 \times 1000}{KVA_B} \dots \dots \dots (4)$$

$$\text{Base Power} = KVA_B$$

Now

$$Z_{pu} = \frac{\text{Actual Impedance}}{\text{Base impedance}} \dots \dots \dots (5)$$

Putting the value of base impedance from the equation (4) in the equation (5) we will get the value of impedance per unit

$$Z_{pu} = \frac{\text{Actual Impedance} \times KVA_B}{(KV_B)^2 \times 1000}$$

Q. 1. Explain the purpose of damper windings used in alternator with neat sketch and derive the resultant emf for short pitched coil of an alternator considering phasor diagram.

Ans. Damper winding: Damper winding is the winding placed in the pole faces of the synchronous machine which makes the synchronous machine self-starting. The damper winding is the small copper wires which are placed in the holes on pole faces each end of the wires are short circuited to form a partial squirrel cage winding.

So first the three phase supply is given to the stator winding revolving flux is set up which induces the emf in the damper winding

It runs on the principle of the three phase induction motor, when motor archives 75% speed of the synchronous speed the rotor winding is energised, under this condition the rotor poles faces the poles of opposite polarity on the stator. Then there becomes strong magnetic attraction between rotor and stator poles.

The poles of the rotor and stator are locked magnetically now the rotor is pulled in steps on synchronous speed.

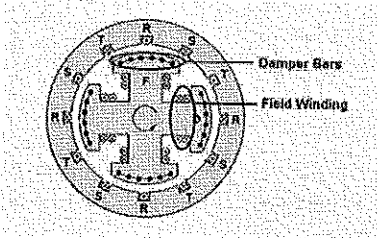

Q. 2. What is the purpose of single line diagram? Explain each component with neat sketch.

Ans. Isolator – The isolator connects or disconnects the incoming circuit when the supply is already interrupted. It is also used for breaking the charging current of the transmission line. The isolator is placed on the supply side of the circuit breaker so that the circuit breaker is isolated from the live parts of the maintenance.

Lightning Arrester – The lightning arrester is a protective device which protects the system from lightning effects. It has two terminals one is high voltage and the other is the ground voltage. The high voltage terminal is connected to the transmission line and the ground terminal passes the high voltage surges to earth.

CT Metering – The metering CT measure and records the current when their secondary terminal is connected to the metering equipment panel.

Step-down Transformer – The step-down transformer converts the high voltage current into the low voltage current.

Capacitor Bank – The capacitor bank consists series or parallel connection of the capacitor. The main function of the capacitor bank is to improve the power factor of the line. It draws the leading current to the line by reducing the reactive component of the circuit.

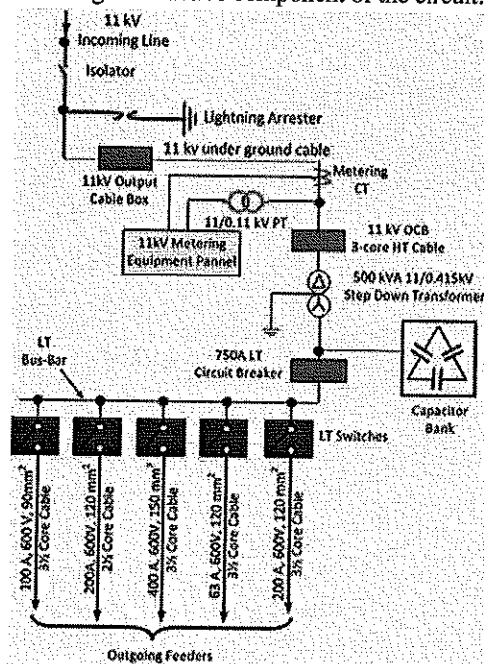

Q. 3. A 5 KVA, 500/250V, 50Hz, single phase transformer gave the following readings:

(a) OC Test: 500V, 1A, 50W (LV side open)

(b) SC Test: 25V, 10A, 60W (LV side shorted)

Determine the efficiency on full load 0.8 lagging power factor.

Ans. For OC TEST $V_0=500V$, $I_0=1A$ and $W_0=50W$

$$\cos(\Phi_0) = (50/500 \cdot 1) = 0.1$$

$$I_c = I_0 \cos(\Phi_0) = 0.1A$$

$$I_m = I_0 \sin(\Phi_0) = 0.9949A$$

$$R_0 = V_0/I_c = 500/0.1 = 5000 \Omega$$

$$X_0 = V_0/I_m = 500/0.9949 = 502.52 \Omega$$

From SC Test: $V_{sc} = 25V$, $I_{sc} = 10A$ and $W_{sc} = 60W$

$$R_{e1} = (W_{sc}/I_{sc}^2) = 60/(10)^2 = 0.6 \Omega$$

$$Z_{e1} = V_{sc}/I_{sc} = 25/10 = 2.5 \Omega$$

$$X_{e1} = \sqrt{(2.5)^2 - (0.6)^2} = 2.4269$$

$$FL = VA \text{ Rating}/V_1 = 10$$

$$I_{sc} = I_1 \cdot FL$$

$$W_{sc} = P_{cu} \cdot FL = 60W.$$

Efficiency on full load at $\cos = 0.8$ lagging

$$\text{Efficiency} = [(VA \text{ rating}) \cos \Phi_2 / (VA \text{ rating}) \cos \Phi_2 + P_i + (P_{cu})FL] \cdot 100$$

$$\text{Efficiency} = [5 \cdot 10^3 \cdot 0.8 / 5 \cdot 10^3 \cdot 0.8 + 50 + 60] \cdot 100$$

$$97.32\%$$

Q. 4. What are the different windings used in transformer? Explain all in detail with neat sketches.

Ans. Core and Windings of Three Phase Core Type Transformer

There are different types of windings used for different kinds of applications and arrangements. Windings are the conductors wrapped in various forms like helical, disc, cylindrical, crossover which generates mmf that is carried by the core to other windings for having the different level of voltages. Mainly there are two types of transformer:

Core type transformer

Shell type transformer

In core type, we wrap the primary, and the secondary winding on the outside limbs and in shell type we place the primary and secondary windings on the inner limbs.

We use concentric type windings in core type transformer. We place low voltage winding near to the core. However, to reduce leakage reactance, windings can be interlaced. Winding for core type depends on many factors like current rating, short circuit withstand capacity, limit of temperature rise, impedance, surge voltage, transport facilities, etc.

Types of Winding used for Core Type Transformer

Cylindrical Windings

These windings are layered type and uses rectangular or round conductor shown in Fig.(a) and (b). The conductors are wound on flat sides shown in Fig.(c) and wound on the rib side in Fig.(d).

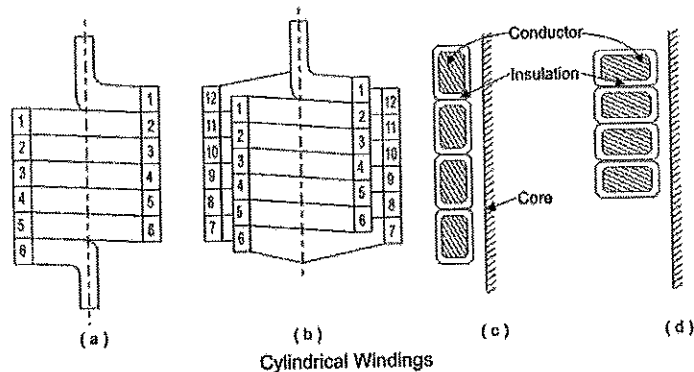

Helical Windings

We use helical windings low voltage, high capacity transformers, where current is higher, at the same time windings turns are lesser. The output of transformer varies from 160 – 1000 kVA from 0.23-15 kV. To secure

adequate mechanical strength the cross-sectional area of the strip not made less than 75-100 mm square. The maximum number of strips used in parallel to make up a conductor is 16.

There are three types:

- Single Helical Winding
- Double Helical Winding
- Disc-Helical Winding

Single Helical Windings consist of winding in an axial direction along a screw line with an inclination. There is only one layer of turns in each winding. The advantage of Double Helical Winding is that it reduces eddy current loss in conductors. This is on account of the reduced number of parallel conductors situated in the radial direction.

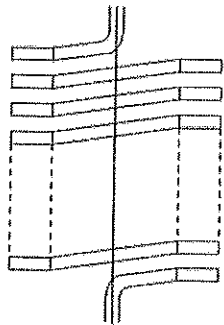

(a) Single Helical Winding

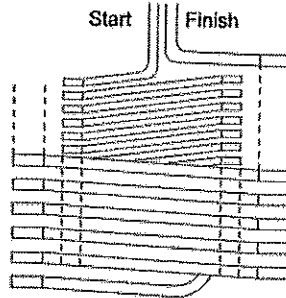

(b) Double Helical Winding

In Disc-Helical Windings, the parallel connected strips are placed side by side in a radial direction to occupy total radial depth of winding.

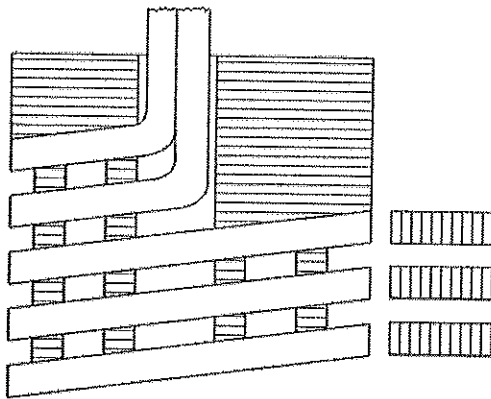

(c) Disc Helical Windings

Multi-layer Helical Winding

We use it commonly for high voltage ratings for 110 kV and above. These types of winding consist of several cylindrical layers concentrically wound and connected in series.

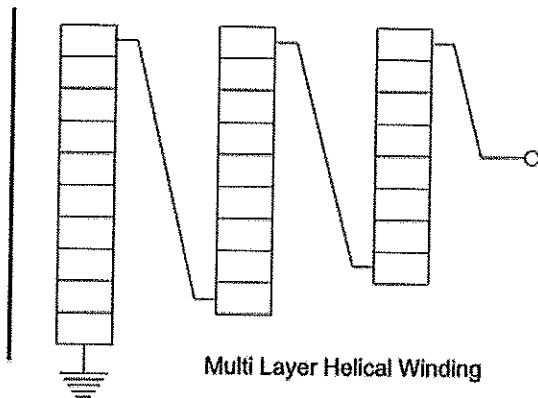

Multi Layer Helical Winding

We make the outer layers shorter than inner layers to distribute capacitance uniformly. These windings primarily improve the surge behaviour of transformers.

Crossover Winding

We use these windings for high voltage windings of small transformers. The conductors are paper covered round wires or strips. The windings are divided into a number of coils in order to reduce voltage between adjacent layers. These coils are axially separated by a distance of 0.5 to 1 mm. The voltages between adjacent coils should not be more than 800 to 1000 V.

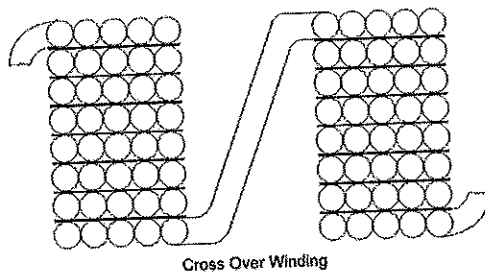

The inside end of a coil is connected to the output side end of the adjacent one as shown in above figure. The actual axial length of each coil is about 50 mm while the spacing between two coils is about 6 mm to accommodate blocks of insulating material. The width of the coil is 25 to 50 mm. The crossover winding has a higher strength than cylindrical winding under normal condition. However, the crossover has lower impulse strength than the cylindrical one. This type also consumes more labour cost.

Disc and Continuous Disc Winding

Primarily used for a high capacity transformer. The winding consist of a number of flat coils or discs in series or parallel. The coils are formed with rectangular strips wound spirally from the centre outwards in the radial direction as shown in the figure below.

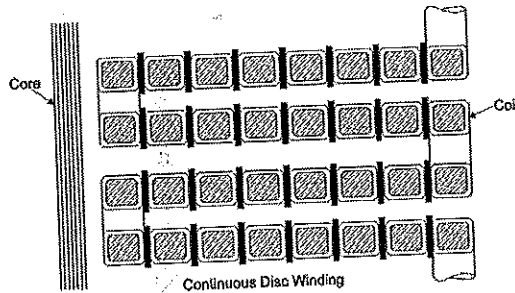

The conductors can be a single strip or multiple strips in a parallel wound on the flat side. This makes robust construction for this type of windings. Discs are separated from each other with press-board sectors attached to vertical strips. The vertical and horizontal spacers provide radial and axial ducts for free circulation of oil which comes in contact with every turn. The area of the conductor varies from 4 to 50 mm square and limits for current are 12 – 600 A. The minimum width of oil duct is 6 mm for 35 kV. The advantage of the disc and continuous windings is their greater mechanical axial strength and cheapness.

Windings for Shell Type Transformer

Sandwich Type Winding

Allow easy control over the reactance the nearer two coils are together on the same magnetic axis, the greater is the proportion of mutual flux and the less is the leakage flux. Leakage can be reduced by subdividing the low and high voltages sections. The end low voltages sections contain half the turns of the normal low voltage sections called half coils.

In order to balance the magnetomotive forces of adjacent sections, each normal section whether high or low voltage carries the same number of ampere-turns. The higher the degree of subdivision, the smaller is the reactance.

Advantages of Shell Type Windings in Transformers

- High short-circuit withstand capability
- High mechanical strength
- High dielectric strength
- Excellent control of leakage magnetic flux
- Efficient cooling capability
- Flexible design
- Compact size.
- Highly Reliable Design

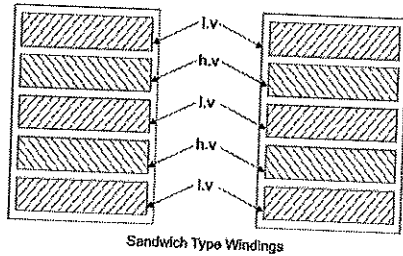

Q. 5. Explain the torque slip characteristics of three phase induction motor.

Ans. Torque Slip Characteristics of Three Phase Induction Motor

The torque slip curve for an induction motor gives us the information about the variation of torque with the slip. The slip is defined as the ratio of difference of synchronous speed and actual rotor speed to the synchronous speed of the machine. The variation of slip can be obtained with the variation of speed that is when speed varies the slip will also vary and the torque corresponding to that speed will also vary.

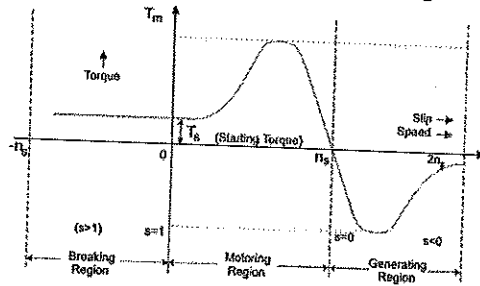

Motoring Mode

In this mode of operation, supply is given to the stator sides and the motor always rotates below the synchronous speed. The induction motor torque varies from zero to full load torque as the slip varies. The slip varies from zero to one. It is zero at no load and one at standstill. From the curve it is seen that the torque is directly proportional to the slip.

That is, more is the slip, more will be the torque produced and vice-versa. The linear relationship simplifies the calculation of motor parameter to great extent.

Generating Mode

In this mode of operation induction motor runs above the synchronous speed and it should be driven by a prime mover. The stator winding is connected to a three phase supply in which it supplies electrical energy. Actually, in this case, the torque and slip both are negative so the motor receives mechanical energy and delivers electrical energy. Induction motor is not much used as generator because it requires reactive power for its operation.

That is, reactive power should be supplied from outside and if it runs below the synchronous speed by any means, it consumes electrical energy rather than giving it at the output. So, as far as possible, induction generators are generally avoided.

Braking Mode

In the Braking mode, the two leads or the polarity of the supply voltage is changed so that the motor starts to rotate in the reverse direction and as a result the motor stops. This method of braking is known as plugging. This method is used when it is required to stop the motor within a very short period of time. The kinetic energy stored in the revolving load is dissipated as heat. Also, motor is still receiving power from the stator which is also dissipated as heat. So as a result of which motor develops enormous heat energy. For this stator is disconnected from the supply before motor enters the braking mode.



Registration No. _____

BHARTIYA SKILL DEVELOPMENT UNIVERSITY
School of Electrical Skills
Third Semester, End Semester Examination
B. Voc. Program, Winter Semester, (Session: 2018-19)

Course Code: ELE 1303

Course Name: Safety Electrical Installation Controller

Time: 3 Hours

Max. Marks: 100

Instructions: Answer all questions from section A, each question carries two marks. Answer any six questions from section B, each question carries five marks. Answer all questions from section C, each question carries ten marks. Scientific calculator can be used.

Section – A

10x2=20 Marks

- Q.1. (A) Is it safe to work near to overhead power line if:
- (a) You are using metal ladder
 - (b) The line is energised
 - (c) When it is not raining
 - (d) The power is switched off
- (B) Why you should not store loose batteries in a tool bag because?
- (a) It will make the bag heavier
 - (b) May catch the fire
 - (c) It will reduce the battery life
 - (d) It may damage the battery
- Q.2. (A) What should you do if you see a live electrical wire falls into a water pond?
- (a) Avoid the area
 - (b) Ignore the wire and report it when you will finish your work
 - (c) Immediately remove the wire from the water
 - (d) Notify others in the area and stay away
- (B) A toolbox is placed in the middle of working area then it can lead to:
- (a) Fatal incidents
 - (b) Stressed employees avoiding to use that space
 - (c) A conflict between the employees
 - (d) Incident of workers tripping over.
- Q.3. (A) What should you do if the first aid box at your workplace is not having all the required items?
- (a) Inform the person who looks after the first aid box
 - (b) Ask all of your colleagues to bring a few items
 - (c) It's not your responsibility so just leave it until the appropriate person can sort it out
 - (d) Purchase your own supplies to top it up.
- (B) What do you mean by hazard?
- (a) Something in wrong place
 - (b) A problem has no solution
 - (c) Something to fall over
 - (d) Something with the potential to cause harm.
- Q.4. (A) In the event of an electrical accident, a first aider is supposed to take action to:
- (a) Move you while you're unconscious
 - (b) Bandage your cuts or wounds
 - (c) Prescribe and give you medicines to help you recover
 - (d) None of these
- (B) What should be done if someone is unconscious and the first aider is not trained?
- (a) Get medical help immediately
 - (b) Move the person on your back
 - (c) Slap the person to see he is alive
 - (d) None of these
- Q.5. (A) Who is responsible to report unsafe working practices?
- (a) It's everyone's responsibility to report unsafe working practices
 - (b) Your supervisor only
 - (c) Only the site manager can do this
 - (d) None of these
- (B) Everyone can help to prevent accidents by:
- (a) Doing the job they think is best
 - (b) Avoiding unsafe acts and unsafe conditions
 - (c) Knowing where the first aid is kept
 - (d) Learning to use a fire extinguisher
- Q.6. (A) Which of the following are the common causes of accidents on a construction site?
- (a) Slips, trips and falls
 - (b) Falling form height
 - (c) Inhaling hazardous substances
 - (d) All of the above
- (B) What is the prime cause of accidents?
- (a) Electrocutation
 - (b) Poisoning
 - (c) Slips, trips and falls
 - (d) Suffocation
- Q.7. (A) Why is it necessary to keep working environment clean and tidy?
- (a) To reduce environmental side effects
 - (b) To reduce the risk of slips, trips and falls
 - (c) To prevent rats and other animals that could damage the goods
 - (d) All of above
- (B) Which of the following is most appropriate for using a powered hand tool
- (a) Below 16-years-old
 - (b) Below 18-years-old
 - (c) Below 21-years-old
 - (d) Trained and competent

- Q.8. (A) Why is it necessary to report an accident?
 (a) So that employees can make a claim for compensation
 (b) So that someone should be responsible for the accident
 (c) So that employees and employer can learn and prevent the same accident in the future
 (d) So that employers can use it for survey purpose in future.
- (B) For fire, which of the following four elements are to be present:
 (a) Smoke, heat, fuel, chemical reaction (b) Fuel, oxygen, heat, chemical reaction
 (c) Aqueous solution, oxygen, smoke, spark (d) Carbon dioxide, fuel, heat, smoke
- Q.9. (A) Which part of the body is gets most affected when someone comes in contact with the live electrical system:
 (a) Head (b) Leg (c) Face (d) Heart
- (B) While working near live conductor electrician should wear:
 (a) Natural cotton clothing (b) Arc flash Personal protective equipment
 (c) Synthetic cotton blends (d) Polyester clothing
- Q.10. (A) A thin piece of wire which is heated and melted by flow of an electric current is called
 (a) Circuit (b) fuse (c) cell (d) resistor
- (B) Which of the following is the most dangerous place to use electrical equipment
 (a) Near a ladder (b) Outdoors
 (c) Near water (d) Near other electrical equipment

Section – B

6x5=30 Marks

Answer any six questions.

- Q.1. Define safety manual? What is the significance of preparing safety manual?
 Q.2. What are personal protective equipment (PPEs)? Why is it necessary to use PPEs at work place?
 Q.3. What are the objectives of safety studies?
 Q.4. What are the safety precautions to be taken care of in small LV installation and residential buildings before carrying out repairing work?
 Q.5. What are reason behind the establishment of lockout, isolation and tagging procedures?
 Q.6. What are the different categories of common electrical hazards? Explain briefly.
 Q.7. What is material safety data sheet? Explain in short.
 Q.8. What do you mean by first aid and who may become a first aider?

Section – C

10x5=50 Marks

Answer all the questions.

- Q.1. Explain electrical safety rules. How electrically safe working conditions can be achieved?
 Q.2. What is an earthing? What are its objectives?
 Q.3. What are the causes of electrical accidents and explain the preventive measures?
 Q.4. What are Indian electricity rules? Explain its objectives?
 Q.5. What is fire? How to avoid it? Explain the various categories of it?

School of Electrical Skills
Third semester, End Semester Examination

Course code: ELE1303

Course Name: Safety Electrical Installation
Controller.

Solution: -

Section - A

1. (A) Ans: - (d)

(B) Ans: - (d)

2. (A) Ans: - (d)

(B) Ans: - (d)

3. (A) Ans: - (a)

(B) Ans: - (d)

4. (A) Ans: - (c)

(B) Ans: - (a)

5. (A) Ans: - (a)

(B) Ans: - (b)

6. (A) Ans: - (d)

(B) Ans: - (c)

7. (A) Ans: - (d)

(B) Ans: - (d)

8. (A) Ans: - (c)

(B) Ans: - (b)

9. (A) Ans: — (d)

(B) Ans: — (a)

10. (A) Ans: — (b)

(B) Ans: — (c)

Section-15

1. Ans: - The safety ~~file~~^{manual} is a record of information. It is prepared by the project supervisor. The purpose of it is to focus on health and safety issue.

2. Ans: PPE is defined as all equipment designed to be worn, or held, to protect against a risk to health and safety. This includes most types of protective clothing and equipment such as eye, foot and head protection, safety harnesses, life jackets, and high visibility clothing. The necessity of PPE at work place is understood by following examples.

1) object falling from a height present the major hazard against which head protection is provided. The head protection includes helmet etc.

2
(ii) The eye are very sensitive to flying particles, hazardous liquids, etc. Types of eye protection include safety goggles etc.

3. Ans:

The objective of safety studies are as follows: -

- (i) To establish safety management system, safety audit system.
- (ii) To achieve 100% safety and 100% security of installation of equipment, human life etc.
- (iii) To bring awareness about safety hazards and safety rules.
- (iv) To minimize loss in case of accident.
- v) Study of unsafe acts and unsafe conditions leading to accidents.

4. Ans:

Before carrying out any repair work in small LV installation, switch-off the main switch, take out the fuse-holders, keep with you till end of repair work.

Some other safety precautions are as follows: -

- 1) Use shock proof appliances.
- ii) Use correct fuse wire.
- iii) MCB are preferred.
- iv) Use good quality of copper wire for wiring.
- v) Replace defective switches immediately.

5. Ans:

Lockout, isolation and tagging procedures are established to protect persons and property in a workplace location from any electrical hazard ~~at~~ why inspections, repairs or maintenance work are being carried out.

6. Ans: -

Three categories of electrical hazard are as follows:

I) electrical shock

II) Arcing

III) Toxic gases associated with arcing hazard.

(I) electric shock: - electric shock ~~can~~ occurs by direct contact with a live part, arcing etc.

(II) Arcing :- A short-circuit fault can cause arc in which electrical energy to be established within very small interval of time.

(III) Toxic gases: - the arcing, burning during electrical fault may cause toxic gases to be emitted which can have an adverse effect on a target organ.

7. Ans: -

MSDS stands for material safety data sheets, which are provided with many products. They generally warn users of any hazards associated with the product. They outline the physical and chemical properties of the product, list precautions that should be taken when using the product.

8. Ans:

First aid is the initial treatment given to a casualty for any injury or sudden illness before arrival of an ambulance, doctor or other medically qualified person.

A first aider is someone who has undergone a training course to administer first aid at work and holds a current first aid certificate.

The aim of first aiders are to preserve life.

Section - c

1. Ans: ; the electrical safety rules are as follows:-

- (i) Live parts shall be de-energized before working on or near them.
- (ii) Even after the exposed parts have been de-energized, they shall still be treated as energized until they are ~~to~~ locked out or ~~to~~ tagged out.

The electrically safe work condition will be achieved by the following process:-

- (i) Determine all possible sources of electrical supply to specific equipm. ent. check applicable up to date drawing, diagrams and identification tags.
- (ii) After properly interrupting the load current, open the disconnecting devices for each source.
- (iii) Apply lockout/tagout devices in accordance with a documented and established policy.

(ii) use adequately rated voltage detector to test each phase conductor or circuit part to verify they are de-energized.

(v) where the possibility of induced voltages or stored electrical energy exists, ground the phase conductors or circuit parts before touching them.

Ans 2:

In an installation, an earthing connects specific parts of that installation with the earth's conductive surface for safety purpose.

The objective of earthing is as follows:

(i) The earth path should be capable of handling magnitude and duration of current as per the overcurrent protection of the system without any fire or flash or explosion.

(ii) Persons in the vicinity of earthen structures and installations shall not be exposed to the dangers of electrical shocks.

(iii) Provide a low impedance path to ground for personal and equipment.

Ans: 3

most electrical accidents result from: -

- (i) unsafe equipment or installation
- (ii) unsafe environment
- (iii) unsafe work practices.

Some ways to prevent these accidents are through use of insulation, guarding, grounding, electrical protective devices and safe work practices.

To largely prevent electrical accident safe work practices are required. examples include:

- (i) de-energizing electrical equipment before inspection or repair.
- (ii) Lockout/tagout procedures to prevent accidental or unexpected startup of electrical equipment.
- (iii) keeping electrical tools properly maintained.
- (iv) exercising - caution when working near energized lines and
- (v) using appropriate personal protective equipment.

4. Ans:

Indian electricity rules are as follows

- (1) Safety of supplier and user of electrical equipment, none of them are subjected to harm.
- (2) Safety precautions are taken at every stage during testing, operation and maintenance of installation and equipment.

The objective is "100% safety and 0% accidents/mishaps".

The motto is "safety at every stage, safety first and safety always".

5. Ans:

Fire is a chemical reaction which will continue if fuel, oxygen and heat are present. To eliminate a fire one of these components must be removed. This is often expressed by means of fire triangle. All three corners of the triangle must be present for

for a fire to burn.

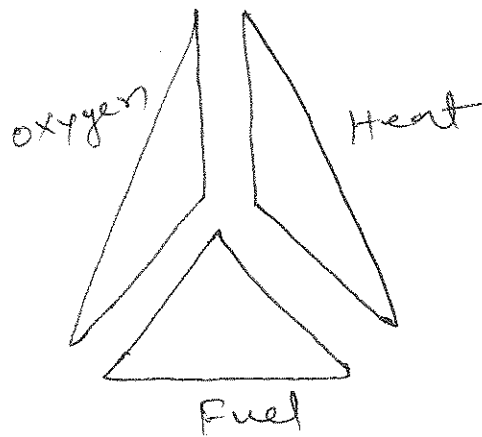

Fire are classified in four categories

- i) class A: are wood, paper and textile fires.
- ii) class B are liquid fires such as paint, petrol and oil.
- iii) class C are fires involving gas or spilled liquefied gases.
- iv) class D are very special type because once started they can be identified as one of four above types.

