

**Bhartiya Skill Development University Jaipur**

School of Electrical Skills
Session: 2019-20 (Summer Semester)
B. Voc. Program, 3rd Semester,
2nd In-Sem. Examination

Course Code: ELE1301

Course Name: Automation and Control

Time: 1 Hour

Max. Marks: 20

Instruction: Answer all questions from section A, each question carries one mark. Answer all questions from section B, each question carries two marks. Answer all questions from section C, each question carries three marks. Scientific calculator is allowed. Draw neat and clean diagram.

Section – A

05X01 = 05 Marks

1. Full form of the DOL starter is:
(a) Direct Online Starter
(b) Dual Online Starter
(c) Direct Overload starter
(d) None of these
2. Scan time is a function of:
(a) Speed of processor
(b) Length of ladder program
(c) Type of instruction
(d) All of these
3. Full form of the HMI is:
(a) Human Machine Instrument
(b) Human Machine Interface
(c) Human Motor Interface
(d) None of these
4. No. of Contactors required to make RDOL starter: -
(a) One
(b) Two
(c) Three
(d) Four
5. The programming software used for Allen Bradley Micrologix PLC is: -
(a) Rockwell Automation
(b) WSZ
(c) Vijeo Designer
(d) None of these

Section – B

03X02 = 06 Marks

1. Explain Sinking and Sourcing types of input with Diagram.
2. Explain the Grounding system of PLC.
3. Draw the control circuit and power circuit diagram of DOL and RDOL starter.

Section – C

03X03 = 09 Marks

1. Explain the scan cycle of single rung program with diagram.
2. Explain Modes of operation of PLC.
3. Explain the working of PLC with block diagram.



BHARTIYA SKILL DEVELOPMENT UNIVERSITY

School of Electrical Skills
Session: 2019-20 (Summer Semester)
B. Voc. Program, IIIrd Semester,
2nd In-Sem. Examination

Course Code: ELE1301
Course Name: Automation and Control

Time: 1 Hour
Max. Marks: 20

Answers sheet
Section A

05X01 = 05 Marks

- 1. (a)Direct Online Starter
2. (d) All of these
3. (b) Human Machine Interface
4. (b) Two
5. (a) Rockwell Automation

Section B

1. Sinking Input: The input energizes when high-level voltage is applied to the input terminal (active high). Connect the power supply VDC (-) to the input group's COM terminal.

Sourcing Input: The input energizes when low-level voltage is applied to the input terminal

1763-L16BBB and 1763-L16DWD Sinking Input Wiring Diagram

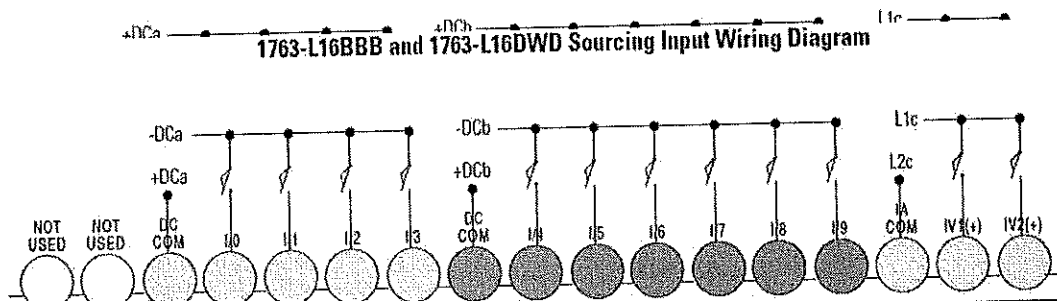

(active low). Connect the power supply VDC (+) to the input group's COM terminal.

2. Grounding: In solid-state control systems, grounding and wire routing helps limit the effects of noise due to electromagnetic interference (EMI). Run the ground connection from the ground screw of the controller to the ground bus prior to connecting any devices. Use AWG #14 wire. For AC powered controllers, this connection must be made for safety purposes.

BHARTIYA SKILL DEVELOPMENT UNIVERSITY

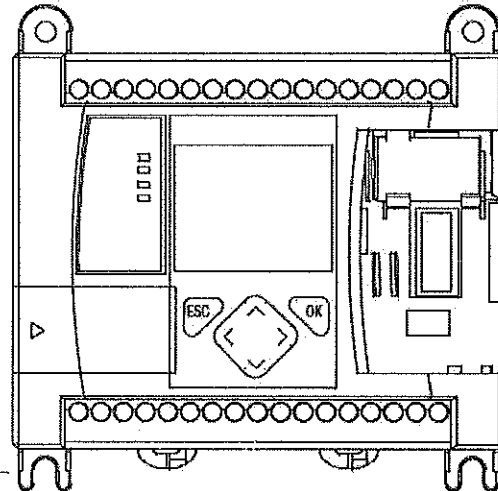

Grounding stamping

3. DOL starter:

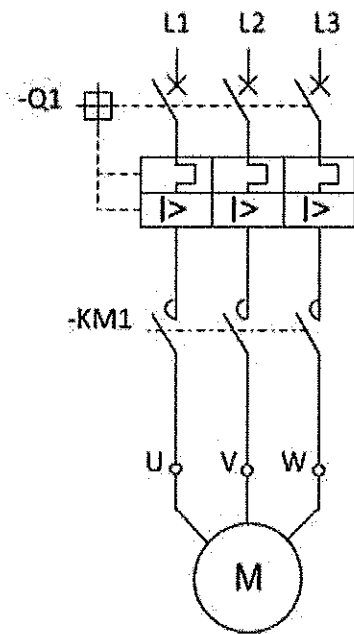

Power Circuit

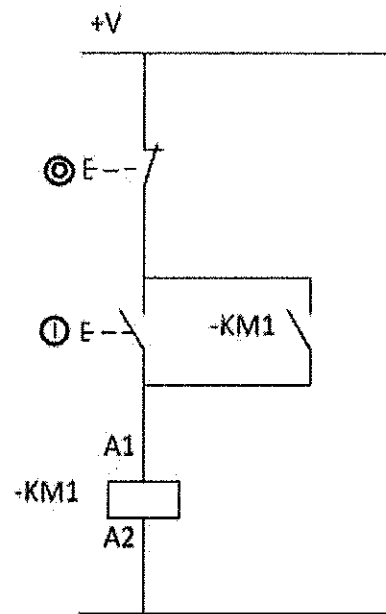

Control Circuit

BHARTIYA SKILL DEVELOPMENT UNIVERSITY

RDOL Starter:

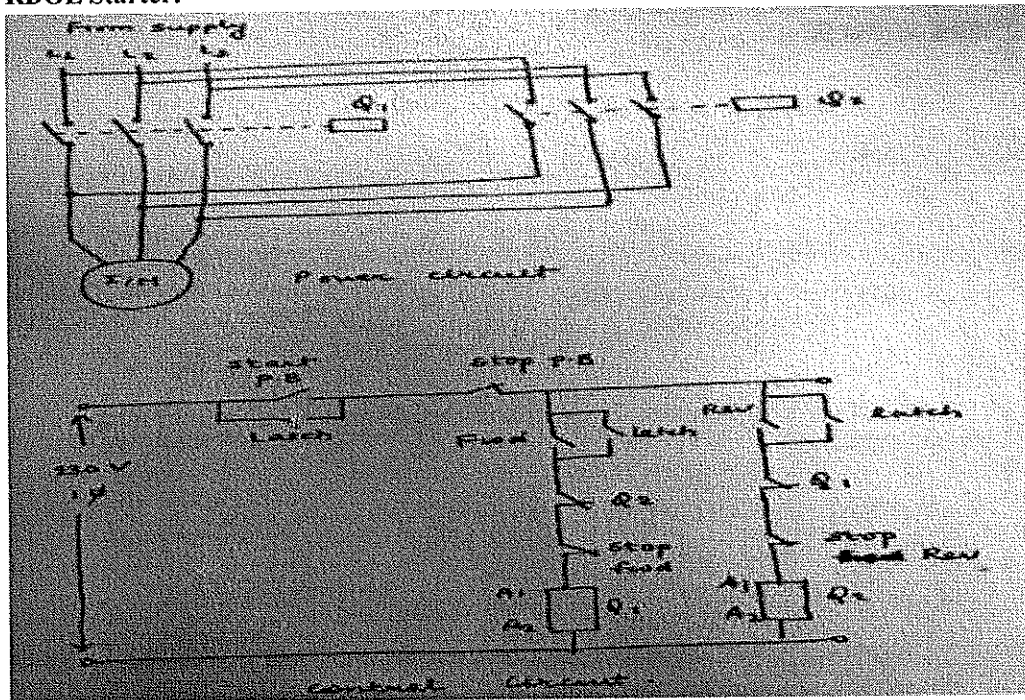

Section C

1. Scan process for a single Rung program:

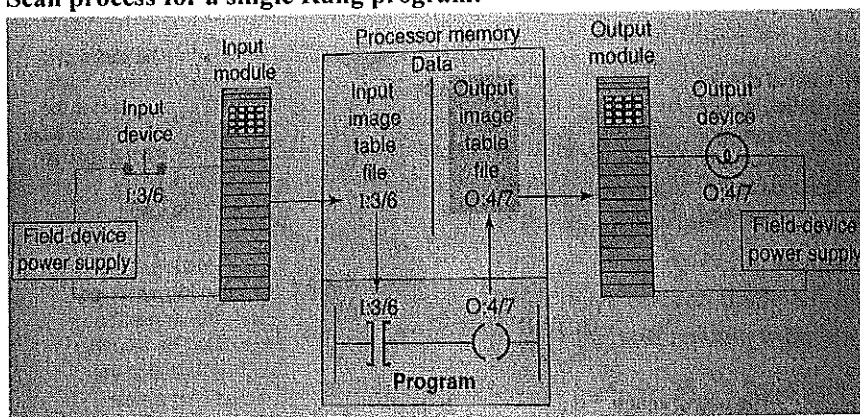

The operation of scan process can be summarized as follows:

- If the input device connected to address I:3/6 is closed, the input module circuitry senses electrical continuity and a 1 (ON) condition is entered into the input image table bit I:3/6.
- During the program scan, the processor examines bit I:3/6 for a 1 (ON) condition.
- In this case, because input I:3/6 is 1, the rung is said to be TRUE or have logic continuity.
- The processor then sets the output image table bit O:4/7 to 1.
- The processor turns ON the output O:4/7 during the next I/O scan, and the output device (light) wired to this terminal become energized.
- This process is repeated as long as the processor is in the RUN mode.
- If the input device is opens, electrical continuity is lost and a 0 would be placed in the input image table. As a result the rung is said to be FALSE due to loss of logic continuity.
- The processor would then set the output image table bit O:4/7 to 0, causing the output device to turn off.

BHARTIYA SKILL DEVELOPMENT UNIVERSITY

2. Mode of operations of PLC

Some common operating modes of PLC are explained as follows:

- 1. Program Mode:** The program mode is used to enter a new program, edit or update an existing program, upload files, download files, document (print out) programs, or change any software configuration file in the program. When the PLC is switched into the program mode, all output are forced off regardless of their rung logic status, and the ladder I/O scan sequence is halted.
- 2. Run Mode:** The Run Mode is used to execute the user program. Input devices are monitored and output devices are energized accordingly. After all instructions have been entered in a new program or all changes made to existing program, the processor is put in the run mode.
- 3. Test Mode:** The test mode is used to operate or monitor the user program without energizing any outputs. The processor still reads inputs, executes the ladder program, and update the output status table files, but without energizing the output circuit. This feature is often used after developing or editing a program to test the program execution before allowing the PLC to operate real-world outputs.
- 4. Remote Mode:** In the Run position, all logic is solved and I/O is enabled. In the program position, all logic solving is stopped and the I/O is disabled. The remote position allows the PLC to be remotely changed between program and run mode by personal computer connected to the PLC processor. The remote mode may be beneficial when the controller is in a location that is not easily accessible.

3. Working of PLC:

The input sources convert the real time analog electric signals to suitable digital electric signals and these signals are applied to the PLC through the connector rails. These input signals are stored in the PLC external image memory in locations known as bits. This is done by the CPU

The control logic or the program instructions are written onto the programming device through symbols or through mnemonics and stored in the user memory.

The CPU fetches these instructions from the user memory and executes the input signals by manipulating, computing, processing them to control the output devices.

The execution results are then stored in the external image memory which controls the output drives.

The CPU also keeps a check on the output signals and keeps updating the contents of the input image memory according to the changes in the output memory.

The CPU also performs internal programming functioning like setting and resetting of the timer, checking the user memory.

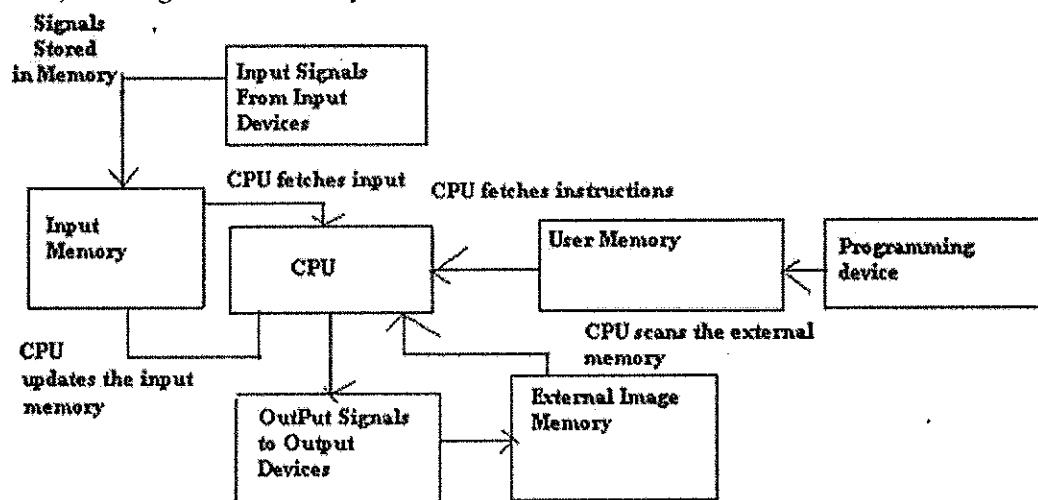

**BHARTIYA SKILL DEVELOPMENT UNIVERSITY**

School of Electrical Skills
Session: 2019-20 (Summer Semester)
B. Voc. Program, 3rd Semester,
2nd In-Sem. Examination

Course Code: ELE1302**Time: 1 Hour****Course Name: Electrical Machine Design Developer****Max. Marks: 20**

Instruction: Answer all questions from section A, each question carries one mark. Answer all questions from section B, each question carries two marks. Answer all questions from section C, each question carries three marks. Scientific calculator is allowed.

Section – A

05X01 = 05 Marks

- Laminated yokes are used:
(a) To reduce copper losses (b) To reduce eddy current losses
(c) To reduce hysteresis losses (d) None of these
- Generation output is always in:
(a) AC (b) DC (c) Discrete (d) None of these
- Commutator is a:
(a) Mechanical rectifier (b) Insulator (c) Inverter (d) None of these
- In LAP wound, no. of parallel paths equal to:
(a) 2 (b) No. of poles (c) 4 (d) None of these
- Brushes are placed on:
(a) GNA (b) Can collect from anywhere (c) MNA (d) None of these

Section – B

03X02 = 06 Marks

- Names the different winding used for motors.
- Draw the flowchart of types of DC generators and draw their circuit diagrams too.
- Explain in brief:
(i) Equalizer ring (ii) Pole pitch

Section – C

03X03 = 09 Marks

- Why carbon brushes placed along MNA in DC?
- A 6 pole LAP connected DC generator with 480 conductors has an armature resistance of 0.06ohm. If the conductors to form a WAVE wound DC generator, other things remaining unchanged, the value of armature resistance will be.
- Develop simplex progressive LAP winding for 24 conductors and 4 poles. (For simplex winding, no. of conductors = no. of slots).

BHARTIYA SKILL DEVELOPMENT UNIVERSITY

School of Electrical Skills

3rd Semester, 2nd In-Sem. Examination

B. Voc. Program, Summer Semester (2019-20)

Course Code: ELE1302

Time: 1 hour

Course Name: Electrical Machine Design Developer

Max Marks: 20

Section – A

1. (b)
2. (a)
3. (a)
4. (b)
5. (c)

Section – B

Ans. 1.

1. Lap Winding
2. Wave Winding

Ans. 2 Flowchart of DC generators drawn below:

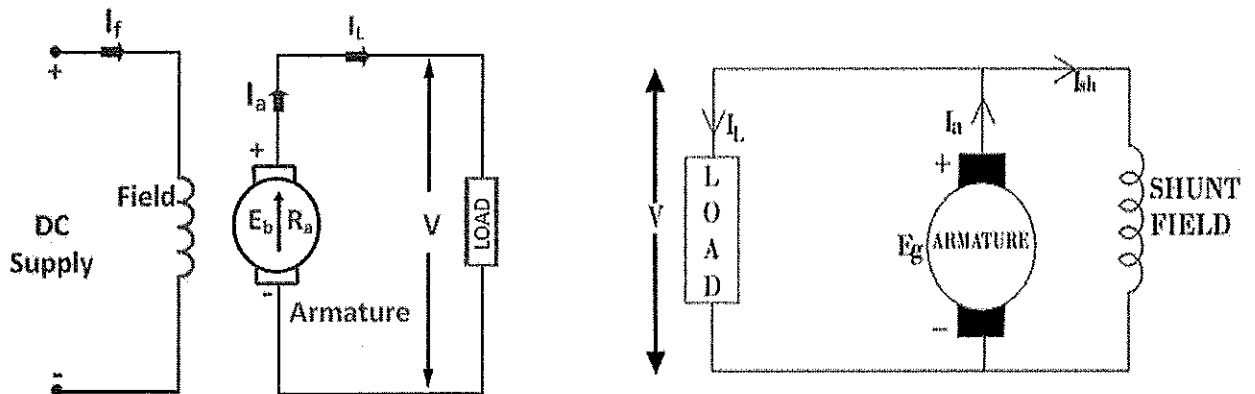
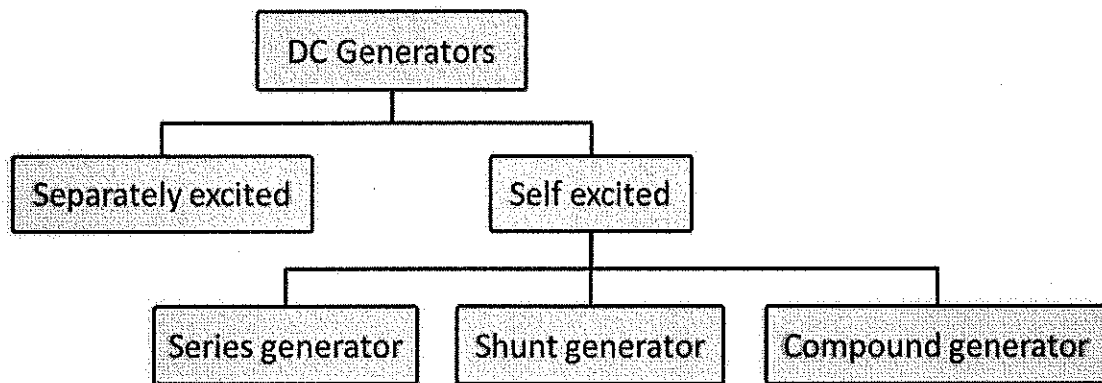

BHARTIYA SKILL DEVELOPMENT UNIVERSITY

Fig. Separately excited DC generator

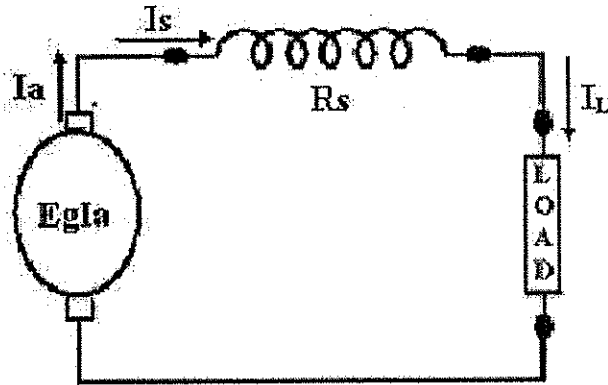

Fig. Self-excited Series DC generator



Fig. Self-excited Short shunt DC generator

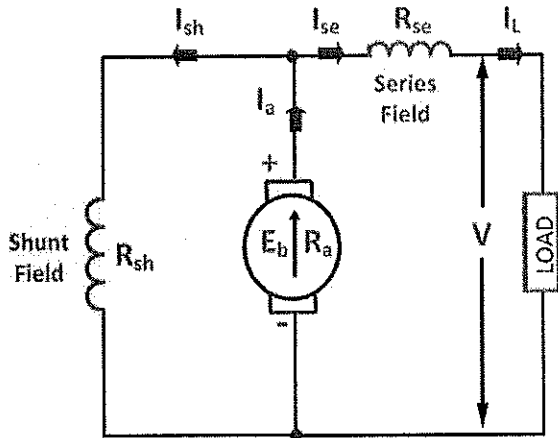

Fig. Self-excited Long shunt DC generator

Ans. 3

(A) Equalizer Ring:

It is a thick solid copper conductor tapped to equipotential coils which are displaced by 360 electrical degrees.

Due to any unbalance induced emf in any of the parallel path circulating current flows which interfere with commutation and produce unwanted sparking. To reduce this sparking, equalizer ring is used which connects those points and hence circulating current will flow through equalizer ring.

(B) Pole Pitch:

BHARTIYA SKILL DEVELOPMENT UNIVERSITY

It is the peripheral distance between two adjacent poles expressed in terms of number of slots or conductors per pole.

$$\text{Pole pitch} = Z/P \text{ OR Slots/Pole}$$

Area under one pole is pole pitch.

Section – C

Ans.1. Carbon brushes are used to collect current due to induced emf from the armature coils in a DC generator. When a brush is at any particular commutator segment, it shorts out that particular coil and draws current from the rest of the coils. If the brush is not exactly at particular segment say one half is in one segment and other half is in a different one, then it draws current in that proportion.

As brushes are always shorting one coil, as it is a short circuit, if emf is induced in that coil, huge current will flow. To prevent this, brushes are positioned in such a way that the coil being short circuited has no induced emf in it. As there is no induced emf, there will be no current and hence no heating losses in brushes and no sparking at commutator segments. It turns out that, the points where induced emf is zero lie along the Magnetic Neutral Axis (MNA), as the name suggests has magnetic neutrality along that axis. So that's why brushes are always placed along MNA axis.

Ans. 2.

Sol.

Given, $Z = 480$
 Poles = 6 = No. of Parallel Path = A

In LAP wound, $R_a = 0.06 \Omega$

$$R_a = \frac{Z^2}{A^2}$$

$$Z = \frac{R_a A^2}{Z} = \frac{0.06 \times 6 \times 6}{480}$$

For WAVE wound { A = 2 }

$$R_a = \frac{Z^2}{A^2} = \frac{0.06 \times 6 \times 6 \times 480}{480 \times 2 \times 2}$$

$$R_a = 0.54 \Omega$$

BHARTIYA SKILL DEVELOPMENT UNIVERSITY

$$\text{Pole pitch} = \frac{Z}{P} = \frac{24}{4} = 6 \text{ Z/pole}$$

Arg. pitch ; $Y_A = \frac{Y_b + Y_f}{2} = \frac{Z}{P} \Rightarrow \text{Lap winding}$

$$\frac{Y_b + Y_f}{2} = 6$$

$$Y_b + Y_f = 12 \quad \text{--- (1)}$$

$$Y_b - Y_f = 2M \rightarrow \text{multiplicity factor}$$

$M=1$ for simplex

$$Y_b - Y_f = 2 \quad \text{--- (2)}$$

$$Y_b = \frac{14}{2} = 7 \quad \& \quad Y_f = 5$$

first coil side	$Y_b = 7$	last coil side	1st coil side	$Y_f = 5$	2nd first coil side
1	$1+7 = 8$		8	$8-5 = 3$	
3	$3+7 = 10$		10	$10-5 = 5$	
5	$5+7 = 12$		12	$12-5 = 7$	
7	$7+7 = 14$		14	$14-5 = 9$	
9	$9+7 = 16$		16	$16-5 = 11$	
11	$11+7 = 18$		18	$18-5 = 13$	

**BHARTIYA SKILL DEVELOPMENT UNIVERSITY**

School of Electrical Skills

Session: 2019-20 (Summer Semester)

B. Voc. Program, 3rd Semester,2nd In-Sem. Examination

Course Code: ELE 1303

Course Name: Electrical Circuit Analysis

Time: 1 Hour

Max. Marks: 20

Instruction: Answer all questions from section A, each question carries one mark. Answer all questions from section B, each question carries two marks. Answer all questions from section C, each question carries three marks. Scientific calculator is allowed.

Section – A

05X01 = 05 Marks

- The two basic components of a Thevenin equivalent ac circuit are:
 - The equivalent voltage source and the equivalent series impedance
 - The equivalent voltage source and the equivalent series resistance
 - The equivalent voltage source and the equivalent parallel impedance
 - The equivalent voltage source and the equivalent parallel resistance
- Norton's theorem gives:
 - An equivalent voltage source in series with an equivalent impedance
 - An equivalent voltage source in parallel with an equivalent impedance
 - An equivalent current source in series with an equivalent impedance
 - An equivalent current source in parallel with an equivalent impedance
- If two currents are in the same direction at any instant of time in a given branch of a circuit, the net current at that instant:
 - Is zero
 - Is the difference between the two currents
 - Cannot be determined
 - Is the sum of the two currents
- In applying the superposition theorem:
 - The sources are considered one at a time with all others replaced by their internal resistance
 - All sources are considered simultaneously
 - All sources are considered independently
 - The sources are considered one at a time with all others replaced by their internal impedance
- In order to get maximum power transfer from a capacitive source, the load must
 - Be as capacitive as it is inductive
 - Have an impedance that is the complex conjugate of the source impedance
 - Have a capacitive reactance equal to circuit resistance
 - None of these

Section – B

03X02 = 06 Marks

- State superposition theorem.
- Given phasor $A = 6.34 + j 13.59$ and phasor $B = 20 \angle - 35^\circ$. Write down the following in:
 - rectangular form and
 - polar form.
- Given phasor $A = 6.34 + j 13.59$ and phasor $B = 16.38 - j 11.47$ write down the $A+B$ in:
 - rectangular form and
 - polar form.

A



BHARTIYA SKILL DEVELOPMENT UNIVERSITY

Section - C

03X03 = 09 Marks

1. A resistance of 10 ohm is connected in series with a 50 mH inductance across a 230 V, 50 Hz supply. Calculate (a) the current flowing in the circuit and (b) the phase angle of current.
2. Find the current in the 6 Ω resistor using the principle of superposition for the circuit of Fig.

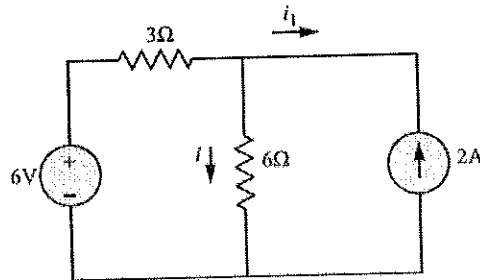

3. Find the load R_L that will result in maximum power delivered to the load for the circuit of Fig. Also determine the maximum power P_{max} .

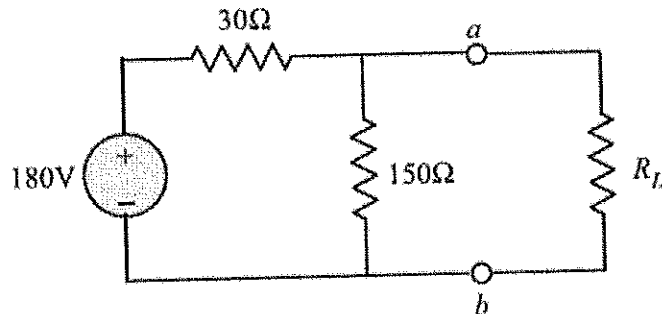

[Handwritten signature]



School of Electrical Skills
Session: 2019-20 (Summer Semester)
B. Voc. Program, 3rd Semester,
1st In-Sem. Examination

Course Code: ELE-1303

Time: 1 Hour

Course Name: Electrical Circuit Analysis

Max. Marks: 20

Section – A

05X01 = 05 Marks

1. (a)
2. (d)
3. (d)
4. (d)
5. (c)

Section – B

03X02 = 06 Marks

Ans. 1.

Ans: The statement of superposition theorem “If a network consists of linear parameters and it has several impressed sources, the response in any branch of network can be evaluated as the sum of the response caused by each impressed source acting separately with all other sources reduces to zero leaving behind their internal resistances.”

In other words, “In any linear network having more than one energy source, the response in any branch of the network is equal to the algebraic sum of all the response due to each individual source acting alone with all other sources replaced by their internal resistance.”

Ans. 2.

Solution In polar form, $A = \sqrt{(6.34)^2 + (13.59)^2} \angle \tan^{-1}(13.59/6.34) = 15 \angle 65^\circ$

In rectangular form, $B = 20[\cos(-35^\circ) + j\sin(-35^\circ)] = 16.38 - j11.47$

Ans. 3.

$$\begin{aligned} A + B &= 6.34 + j13.59 + 16.38 - j11.47 = 22.72 + j2.12 \\ &= \sqrt{(22.72)^2 + (2.12)^2} \angle \tan^{-1}(2.12/22.72) = 22.82 \angle 5.33^\circ \end{aligned}$$



Ans. 1.

Solution (a) Let the supply voltage V be assumed as the reference phasor. Then $V = 230 \angle 0^\circ$.

$$X_L = 2\pi fL = 2\pi \times 50 \times 50 \times 10^{-3} = 15.71 \Omega$$

$$Z = R + jX_L = 10 + j15.71$$

$$\therefore Z = \sqrt{10^2 + 15.71^2} = \sqrt{346.8} = 18.62 \Omega$$

$$I = \frac{V}{Z} = \frac{230}{18.62} = 12.35 \text{ A}$$

$$(b) \varphi = \tan^{-1} \frac{X_L}{R} = \tan^{-1} \frac{15.71}{10} = -57.52^\circ \text{ lag or } \angle -57.52^\circ$$

Ans. 2.

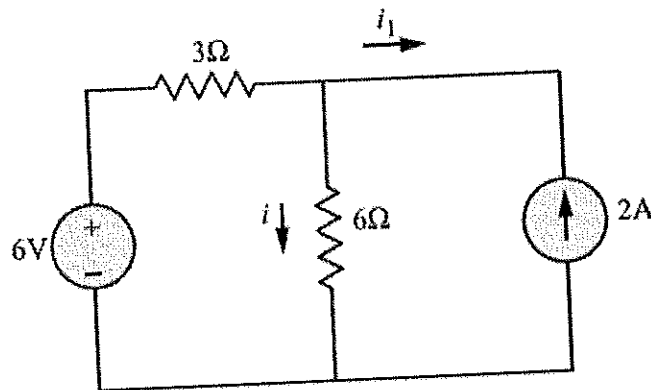

As a first step, set the current source to zero. That is, the current source appears as an open circuit as shown in Fig.

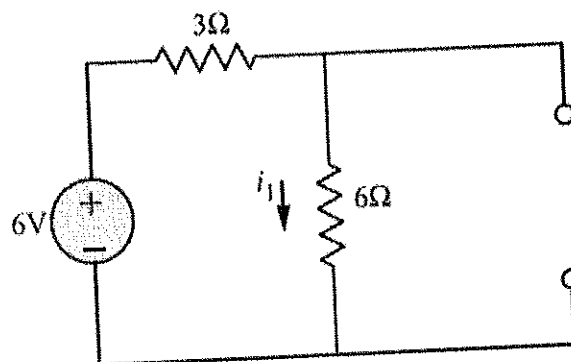

$$i_1 = \frac{6}{3+6} = \frac{6}{9} \text{ A}$$

As a next step, set the voltage to zero by replacing it with a short circuit as shown in Fig.

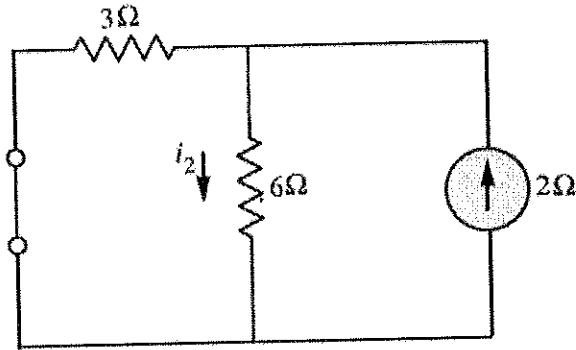

$$i_2 = \frac{2 \times 3}{3 + 6} = \frac{6}{9} \text{ A}$$

The total current i is then the sum of i_1 and i_2

$$i = i_1 + i_2 = \frac{12}{9} \text{ A}$$

Ans. 3.

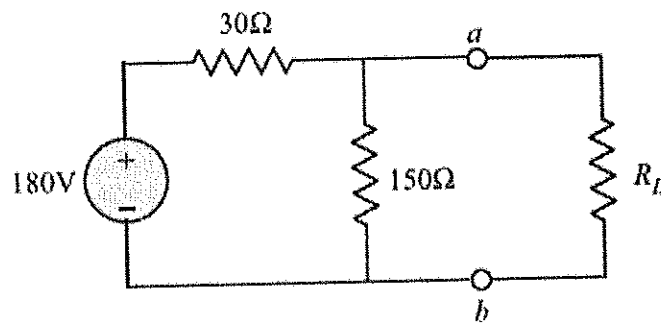

Ans: Disconnect the load resistor R_L . This results in a circuit diagram as shown in Fig.

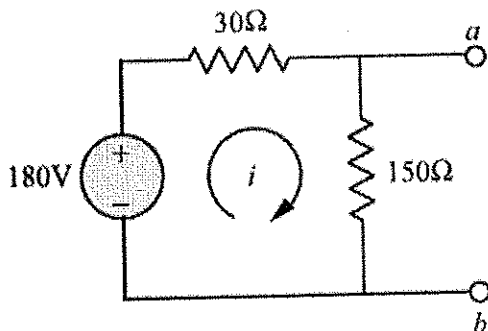

Next let us determine the Thevenin equivalent circuit as seen from a-b

$$i = \frac{180}{150 + 30} = 1 \text{ A}$$
$$V_{oc} = V_t = 150 \times i = 150 \text{ V}$$

To find R_t , deactivate the 180 V source. This results in the circuit diagram of Fig.

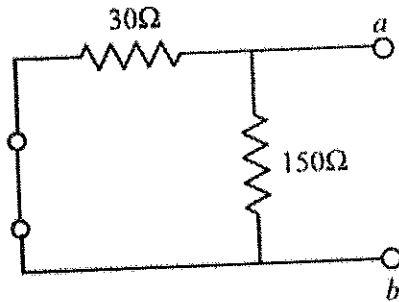

$$R_t = R_{ab} = 30 \Omega || 150 \Omega$$
$$= \frac{30 \times 150}{30 + 150} = 25 \Omega$$

The Thevenin equivalent circuit connected to the load resistor is shown in Fig.

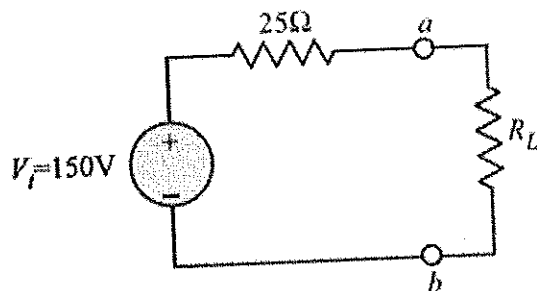

Maximum power transfer is obtained when $R_L = R_t = 25 \Omega$.

Then the maximum power is

$$P_{\max} = \frac{V_t^2}{4R_L} = \frac{(150)^2}{4 \times 25}$$
$$= 2.25 \text{ Watts}$$

The Thevenin source V_t actually provides a total power of

$$P_t = 150 \times i$$
$$= 150 \times \left(\frac{150}{25 + 25} \right)$$
$$= 450 \text{ Watts}$$

Thus, we note that one-half the power is dissipated in R_L .

**BHARTIYA SKILL DEVELOPMENT UNIVERSITY**

School of Electrical Skills
Session: 2019-20 (Summer Semester)
B. Voc. Program, 3rd Semester,
2nd In-Sem. Examination

Course Code: ELE 1304

Time: 1 Hour

Course Name: Electrical Measuring Instruments

Max. Marks: 20

Instruction: Answer all questions from section A, each question carries one mark. Answer all questions from section B, each question carries two marks. Answer all questions from section C, each question carries three marks. Scientific calculator is allowed.

Section – A

05X01 = 05 Marks

1. A dynamometer instrument is chiefly used as a:
(a) DC ammeter (b) DC voltmeter (c) wattmeter (d) None of these
2. Deflecting torque of dynamometer type instruments are calculated by:
(a) Only fixed coil (b) Only moving coil
(c) Both fixed and moving coil (d) None of these
3. Frictional losses in dynamometer type instruments are:
(a) Higher (b) Lower (c) Constant (d) Exponential
4. The range of ammeter and voltmeter with high precision in dynamometer instruments is:
(a) 50A, 600V (b) 100A, 600V (c) 10A, 500V (d) 10A, 600V
5. Which instrument has narrow slot opening
(a) PMMC (b) Dynamometer type
(c) Moving Iron (d) Any of the above

Section – B

03X02 = 06 Marks

1. What are the different types of errors in dynamometer type instruments?
2. What are the advantages and disadvantages of PMMC instruments?
3. A permanent moving coil instrument has a coil of dimensions 10mm X 8mm. The flux density in the air gap is 0.15 Wb/m^2 . If the coil is wound for 100 turns, carrying a current of 5mA, then calculate the deflecting torque. Calculate the deflection if the spring constant is 0.2×10^{-6} .

Section – C

03X03 = 09 Marks

1. Prove that the deflection torque is directly proportional to the current passing through the coil for PMMC instruments.
2. Explain the terms Transfer Instruments, Calibration and Multiplier for dynamometer type instruments.
3. Derive the torque equation in moving iron instruments.

Handwritten signature
A





BHARTIYA SKILL DEVELOPMENT UNIVERSITY

School of Electrical Skills
Session: 2019-20 (Summer Semester)
B. Voc. Program, 3rd Semester,
2nd In-Sem. Examination

Course Code: ELE 1304
Course Name: Electrical Measuring Instruments

Time: 1 Hour
Max. Marks: 20

Section – A

05X01 = 05 Marks

1. A dynamometer instrument is chiefly used as a:

Ans. (c) wattmeter

2. Deflecting torque of dynamometer type instruments are calculated by:

Ans. (c) Both fixed and moving coil

3. Frictional losses in dynamometer type instruments are:

Ans. (a) Higher

4. The range of ammeter and voltmeter with high precision in dynamometer instruments is:

Ans. (d) 10A, 600V

5. Which instrument has narrow slot opening:

Ans. (c) Moving Iron

Section – B

03X02 = 06 Marks

1. What are the different types of errors in dynamometer type instruments?

Ans.

Errors in Electrodynamometer Instruments

The various errors in electro-dynamometer instruments are,

1. **Torque to weight ratio** : To have reasonable deflecting torque, mmf of the moving coil must be large enough. Thus $mmf = NI$ hence current through moving coil should be high or number of turns should be large. The current can not be made very high because it may cause excessive heating of springs. Large number of turns hence is the only option but it increases weight of the coil. This makes the system heavy reducing torque to weight ratio. This can cause frictional errors in the reading.

2. **Frequency errors** : The changes in the frequency causes to change self inductances of moving coil and fixed coil. This causes the error in the reading. The frequency error can be reduced by having equal time constants for both fixed and moving coil circuits.

3. **Eddy current errors** : In metal parts of the instrument the eddy currents get produced. The eddy currents interact with the instrument current, to cause change in the deflecting torque, to cause error. Hence metal parts should be kept as minimum as possible. Also the resistivity of the metal parts used must be high, to reduce the eddy currents.

4. **Stray magnetic field error** : Similar to moving iron instruments the operating field in electro-dynamometer instrument is very weak. Hence external magnetic field can interact with the operating field to cause change in the deflection, causing the error. To reduce the effect of stray magnetic field, the shields must be used for the instruments.

5. **Temperature error** : The temperature errors are caused due to the self heating of the coil, which causes change in the resistance of the coil. Thus temperature compensating resistors can be used in the precise instrument to eliminate the temperature errors.

**BHARTIYA SKILL DEVELOPMENT UNIVERSITY**

2. What are the advantages and disadvantages of PMMC instruments?

Ans.

Advantages

The various advantages of PMMC instruments are,

- 1) It has uniform scale.
- 2) With a powerful magnet, its torque to weight ratio is very high. So operating current is small.
- 3) The sensitivity is high.
- 4) The eddy currents induced in the metallic former over which coil is wound, provide effective damping.
- 5) It consumes low power, of the order of 25 W to 200 μ W.
- 6) It has high accuracy.
- 7) Instrument is free from hysteresis error.
- 8) Extension of instrument range is possible.
- 9) Not affected by external magnetic fields called stray magnetic fields.

Disadvantages

The various disadvantages of PMMC instruments are,

- 1) Suitable for d.c. measurements only.
- 2) Ageing of permanent magnet and the control springs introduces the errors.
- 3) The cost is high due to delicate construction and accurate machining.
- 4) The friction due to jewel-pivot suspension.

3. A permanent moving coil instrument has a coil of dimensions 10mm X 8mm. The flux density in the air gap is 0.15Wb/m². If the coil is wound for 100 turns, carrying a current of 5mA, then calculate the deflecting torque. Calculate the deflection if the spring constant is 0.2*10⁻⁶.

Ans.

Sol.: The deflecting torque is given by,

$$T_d = NBAI = 100 \times 0.15 \times (A) \times 5 \times 10^{-3} \text{ Nm}$$

Now

$$A = \text{area} = 10 \times 8 = 80 \text{ mm}^2 = 80 \times 10^{-6} \text{ m}^2$$

\therefore

$$T_d = 100 \times 0.15 \times 80 \times 10^{-6} \times 5 \times 10^{-3} = 6 \times 10^{-6} \text{ Nm}$$

Now

$$T_d = T_s = K\theta$$

\therefore

$$6 \times 10^{-6} = 0.2 \times 10^{-6} \times \theta$$

\therefore

$$\theta = \frac{6 \times 10^{-6}}{0.2 \times 10^{-6}} = 30 \text{ degrees}$$

Section – C

03X03 = 09 Marks

1. Prove that the deflection torque is directly proportional to the current passing through the coil for PMMC instruments.

Ans.

BHARTIYA SKILL DEVELOPMENT UNIVERSITY

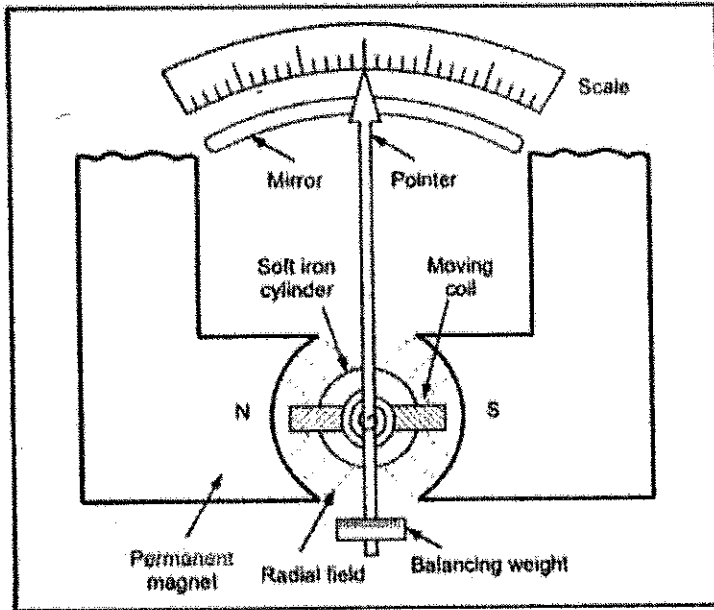

PMMC Instrument

The equation for the developed torque can be obtained from the basic law of the electromagnetic torque. The deflecting torque is given by,

$$T_d = NBAI$$

where

T_d = deflecting torque in N-m

B = flux density in air gap, Wb/m^2

N = number of turns of the coil

A = effective coil area m^2

I = Current in the moving coil, amperes

∴

$$T_d = GI$$

where

$G = NBA = \text{constant}$

The controlling torque is provided by the springs and is proportional to the angular deflection of the pointer.

$$T_c = K\theta$$

where

T_c = controlling torque

K = spring constant, Nm/rad or Nm/deg

θ = angular deflection

For the final steady state position,

$$T_d = T_c$$

∴

$$GI = K\theta$$

∴

$$\theta = \left(\frac{G}{K}\right)I$$

or

$$I = \left(\frac{K}{G}\right)\theta$$

Thus the deflection is directly proportional to the current passing through the coil. The pointer deflection can therefore be used to measure current.

2. Explain the terms resolution, sensitivity and accuracy.

Ans.

Resolution: is the minimal change of the input necessary to produce a detectable change at the output. In other words, the smallest to be distinguished magnitude from the measured value.

BHARTIYA SKILL DEVELOPMENT UNIVERSITY

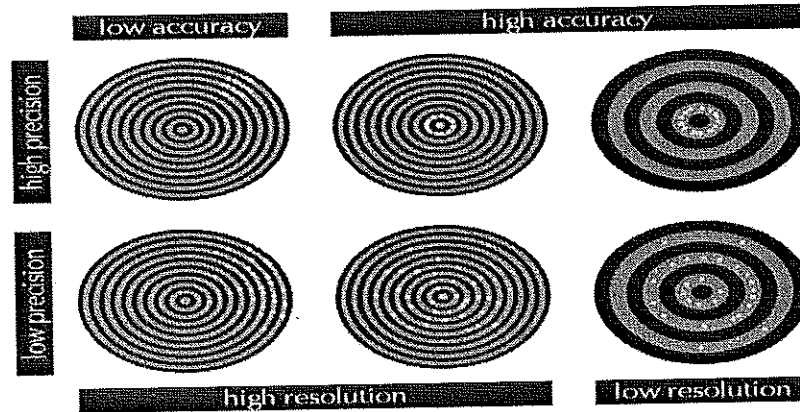

Sensitivity:

- The slope of the calibration curve $y=f(x)$ is g . An ideal sensor will have a large and constant sensitivity
- It is the ratio of change in output to change in input. If Y be the output quantity in response to input X , then sensitivity S can be expressed as

$$S = \frac{dY}{dX} = \frac{\Delta Y}{\Delta X}$$

Accuracy: is the capacity of a measuring instrument to give RESULTS close to the TRUE VALUE of the measured quantity.

- Accuracy is measured by the absolute and relative errors
- The measurement value (which is sometimes referred to simply as the measurement) is the value given by a measuring instrument and the true value is the actual value of the property being measured.

<p>ABSOLUTE ERROR = RESULT - TRUE VALUE</p> <p>RELATIVE ERROR = $\frac{\text{ABSOLUTE ERROR}}{\text{TRUE VALUE}}$</p>
--

3. Derive the torque equation in moving iron instruments.

Ans.

BHARTIYA SKILL DEVELOPMENT UNIVERSITY

1.8.3 Torque Equation of Moving Iron Instruments

Consider a small increment in current supplied to the coil of the instrument. Due to this current let $d\theta$ be the deflection under the deflecting torque T_d . Due to such deflection, some mechanical work will be done.

$$\text{Mechanical work} = T_d d\theta$$

There will be a change in the energy stored in the magnetic field due to the change in inductance. This is because the vane tries to occupy the position of minimum reluctance hence the force is always in such a direction so as to increase the inductance of coil. The inductance is inversely proportional to the reluctance of the magnetic circuit of coil.

- Let
- I = initial current
 - L = instrument inductance
 - θ = deflection
 - dI = increase in current
 - $d\theta$ = change in deflection
 - dL = change in inductance

In order to effect an increment dI in the current, there must be an increase in the applied voltage given by,

$$e = \frac{d(LI)}{dt} \\ = I \frac{dL}{dt} + L \frac{dI}{dt} \quad \text{as both } I \text{ and } L \text{ are changing.}$$

The electrical energy supplied is given by,

$$e I dt = \left(I \frac{dL}{dt} + L \frac{dI}{dt} \right) I dt \\ = I^2 dL + LI dI$$

The stored energy increases from $\frac{1}{2} LI^2$ to $\frac{1}{2} (L + dL) (I + dI)^2$

Hence the change in the stored energy is given by,

$$= \frac{1}{2} (L + dL) (I + dI)^2 - \frac{1}{2} LI^2$$

Neglecting higher order terms, this becomes, $LI dI + \frac{1}{2} I^2 dL$

The energy supplied is nothing but increase in stored energy plus the energy required for mechanical work done.

$$I^2 dL + LI dI = LI dI + \frac{1}{2} I^2 dL + T_d d\theta$$

$$T_d d\theta = \frac{1}{2} I^2 dL$$

$$T_d = \frac{1}{2} I^2 \frac{dL}{d\theta}$$

While the controlling torque is given by,

$$T_c = K\theta$$

where K = spring constant

$$K\theta = \frac{1}{2} I^2 \frac{dL}{d\theta} \quad \text{under equilibrium}$$

$$\theta = \frac{1}{2} \frac{I^2 dL}{K d\theta}$$

Thus the deflection is proportional to the square of the current through the coil. And the instrument gives square law response.



BHARTIYA SKILL DEVELOPMENT UNIVERSITY

School of Electrical Skills

Session: 2019-20 (Summer Semester)

B. Voc. Program, 3rd Semester,
2nd In-Sem. Examination

20.11.2019

2:00 - 3:00

Course Code: ELE 1305

Time: 1 Hour

Course Name: Introduction to Power System

Max. Marks: 20

Instruction: Answer all questions from section A, each question carries one mark. Answer all questions from section B, each question carries two marks. Answer all questions from section C, each question carries three marks. Scientific calculator is allowed.

Section – A

05X01 = 05 Marks

- Which among these HVDC projects are commissioned in India?
 - Rihand – Delhi HVDC
 - Vindhyachal Back to Back only
 - Chandrapur only
 - All of these
- At what condition does the corona start, if E_s is the electrical stress and E_{cr} is the critical voltage?
 - $E_s > E_{cr}$
 - $E_s = E_{cr}$
 - $E_s < E_{cr}$
 - $E_s \ll E_{cr}$
- As compared with the HVAC lines, dc transmission system is free from:
 - Inductance
 - Capacitance
 - Phase displacement
 - All of these
- HVDC system has charging current but no skin effect while transferring the power through it.
 - True
 - False
- In short overhead transmission line (up to 80 km), we may neglect:
 - Series resistance
 - Shunt conductance
 - Shunt capacitance
 - Both shunt conductance and capacitance

Section – B

03X02 = 06 Marks

- Write the advantages of AC transmission system over DC.
- Define Skin effect.
- What are the factors affecting the proximity effect?

Section – C

03X03 = 09 Marks

- Draw and explain the single line diagram of power supply system.
- Write the advantages of using HVDC system.
- What are different components of HVDC Transmission system? Explain any three in detail.

[Handwritten signature]
A

**BHARTIYA SKILL DEVELOPMENT UNIVERSITY**

School of Electrical Skills
Session: 2019-20 (Summer Semester)
B. Voc. Program, III Semester,
2nd In-Sem. Examination

Course Code: ELE 1305

Course Name: Introduction to Power System

Time: 1 Hour

Max. Marks: 20

SOLUTION**Section – A**

05X01 = 05 Marks

Objective type questions, each questions carries 01 marks	
1. (d)	
2. (a)	
3. (d)	
Explanation: All the factors which involve frequency will be absent in dc system as in $f=0$ in dc.	
4. (b)	
Explanation: Skin effect as well as the charging effect, both are absent in dc transmission system.	
5. (d)	

Section – B

03X02 = 06 Marks

Short answer type questions, each question carries 02 marks.	
(1)	Write the advantages of AC transmission system over DC.
Ans	<ul style="list-style-type: none">• The alternating voltages can easily be stepped up and down, which is not possible in DC transmission system.• Maintenance of AC substation is quite easy and economical compared to DC.
(2)	Define Skin effect.
Ans	The non-uniform distribution of electric current over the surface or skin of the conductor carrying a.c is called the skin effect. In other words, the concentration of charge is more near the surface as compared to the core of the conductor. The ohmic resistance of the conductor is increased due to the concentration of current on the surface of the conductor.
(3)	What are the factors affecting the proximity effect.
	The proximity effect mainly depends on the factors like conductors material, conductor diameter, frequency and conductor structure. The factors are explained below in details <ol style="list-style-type: none">1. Frequency – The proximity increases with the increases in the frequency.2. Diameter – The proximity effect increases with the increase in the conductor.3. Structure – This effect is more on the solid conductor as compared to the stranded conductor (i.e., ASCR) because the surface area of the stranded conductor is smaller than the solid conductor.4. Material – If the material is made up of high ferromagnetic material then the proximity effect is more on their surface.

BHARTIYA SKILL DEVELOPMENT UNIVERSITY

Section – C

03X03 = 09 Marks

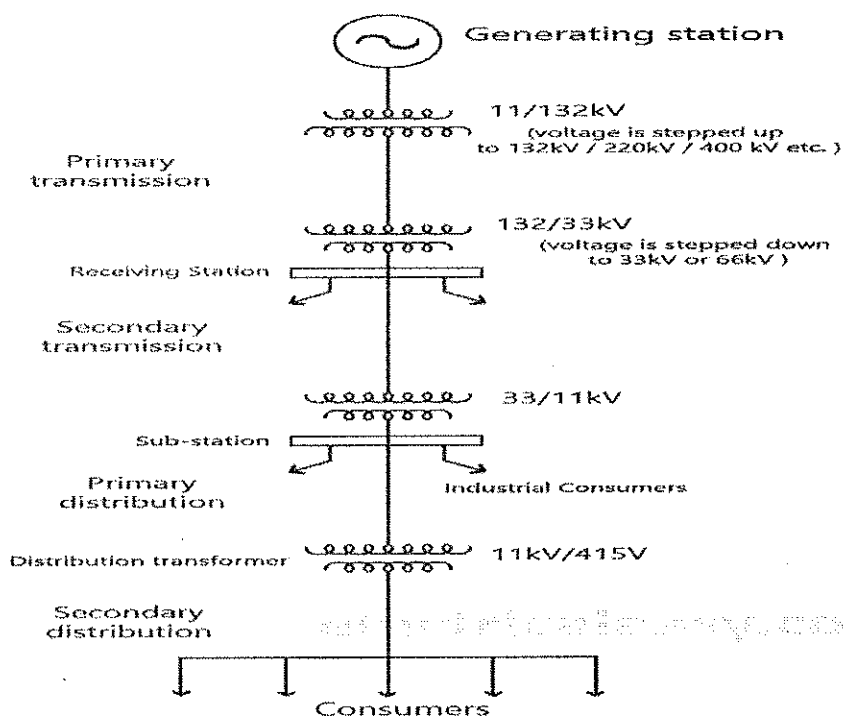
	Essay type questions, each question carries 03 marks.
(1)	Draw and explain the single line diagram of power supply system.
Ans	 <p>The diagram illustrates the single-line diagram of a power supply system. It starts with a Generating station at the top, represented by a circle with a sine wave. Below it is a transformer labeled 11/132kV with a note: "(voltage is stepped up to 132kV / 220kV / 400 kV etc.)". This is followed by a vertical line representing Primary transmission. Below this is a Receiving Station with a transformer labeled 132/33kV and a note: "(voltage is stepped down to 33kV or 66kV)". This is followed by another vertical line representing Secondary transmission. Below this is a Sub-station with a transformer labeled 33/11kV. From the sub-station, the line branches into Primary distribution (left) and Industrial Consumers (right). Below the sub-station is a Distribution transformer labeled 11kV/415V. This is followed by a vertical line representing Secondary distribution. Finally, the line branches into Consumers at the bottom.</p>
(2)	Write the advantages of using HVDC system.
Ans	<ul style="list-style-type: none"> • Only two conductors are required for DC transmission system. It is further possible to use only one conductor of DC transmission system if the earth is utilized as the return path of the system. • The potential stress on the insulator of the DC transmission system is about 70% of the equivalent voltage AC transmission system. Hence, DC transmission systems have reduced insulation costs. • <u>Inductance, capacitance</u>, phase displacement and surge problems can be eliminated in DC system.
(3)	What are different components of HVDC Transmission system? Explain any three in detail.
Ans	<ol style="list-style-type: none"> 1. Converters 2. Smoothing reactors 3. Harmonic filters 4. Reactive power supplies 5. Electrodes 6. DC lines 7. AC circuit breakers



BHARTIYA SKILL DEVELOPMENT UNIVERSITY

Converters

- They perform AC/DC and DC/AC conversion
- They consist of valve bridges and transformers
- Valve bridge consists of high voltage valves connected in a 6-pulse or 12-pulse arrangement
- The transformers are ungrounded such that the DC system will be able to establish its own reference to ground

Smoothing reactors

- They are high reactors with inductance as high as 1 H in series with each pole
- They serve the following:
 - They decrease harmonics in voltages and currents in DC lines
 - They prevent commutation failures in inverters
 - Prevent current from being discontinuous for light loads

Harmonic filters

- Converters generate harmonics in voltages and currents. These harmonics may cause overheating of capacitors and nearby generators and interference with telecommunication systems
- Harmonic filters are used to mitigate these harmonics

