



School of Electrical Skills

Session: 2020-21 (Summer Semester)

B. Voc. Program, 3rd Semester,

End-Sem. Examination

Course Code: ELE 1301

Time: 2 Hours

Course Name: Automation & Control

Max. Marks: 50

Instruction: Answer all questions from section A, each question carries one mark. Answer all questions from section B, each question carries four marks. Answer all questions from section C, each question carries six marks. Scientific calculator is allowed.

Section - A

10X01 = 10 Marks

1. The Boolean representation of this PLC program is:

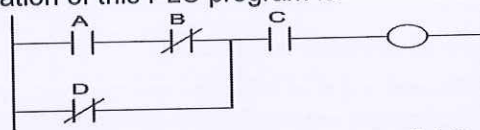

(a) $C + (A + B)D$
(c) $ABC + BD$

(b) $C + D(A + B)$
(d) $C(AB + D)$

2. An OR function implemented in ladder logic uses:

(a) Normally-open contacts in series
(c) Normally-open contacts in parallel

(b) A single normally-closed contact
(d) Normally-closed contacts in parallel

3. A NAND gate has inputs and output.

(a) LOW inputs and LOW outputs
(c) LOW inputs and HIGH outputs

(b) HIGH inputs and HIGH outputs
(d) None of these

4. The capability of convention relay systems for complex operations is _____ that of the PLCs.

(a) poor than
(c) as good as

(b) excellent than
(d) unpredictable as

5. _____ of PLCs can be done in very little time.

(a) Programming
(c) Commissioning

(b) Installation
(d) All of these

6. From which of the following is type of control system.

(a) Closed loop control system
(c) Both (A) & (B)

(b) Open loop control system
(d) None of these

7. When _____ contacts are actuated; they disrupt the power supply through them.

(a) normally open type
(c) both a. and b.

(b) normally closed type
(d) none of these

8. To reset the time for a PLC what condition must be true.

(a) Reset rung of TON must be true
(b) Reset rung of TON must be false
(c) RST instruction with timer address must be true
(d) RST instruction with associated timer address must be false

9. Which of the following is not a comparison instruction?

(a) GEQ (b) EQU (c) LIM

(d) MOV

Pravin
A

10. What is the full form of SCADA?

- (a) Supervisory Control and Document Acquisition
- (b) Supervisory Control and Data Acquisition
- (c) Supervisory Column and Data Assessment
- (d) Supervisory Column and Data Assessment

Section – B

04X04 = 16 Marks

1. What is the PLC Scan Cycle? Explain in detail.
2. Differentiate between fixed and programmable automation system with example.
3. Write important ladder relay instruction and symbols used in programming.
4. What is the difference between timers and counters?

Section – C

04X06 = 24 Marks

1. What are the different types of counters used in PLC?
2. Which types of input sensors are used in automation?
3. How programmable logic controllers work? Explain with architecture.
4. Determine input/output and PLC ladder program of the following sequential task.

Task is as follows:

- (a) Start button is pressed.
- (b) Table motor is started.
- (c) Package moves to the position of the limit switch and automatically stops.

Other auxiliary features include:

- A stop button that will stop the table, for any reason, before the package reaches the limit switch position
- A red pilot light to indicate the table is stopped
- A green pilot light to indicate the table is running

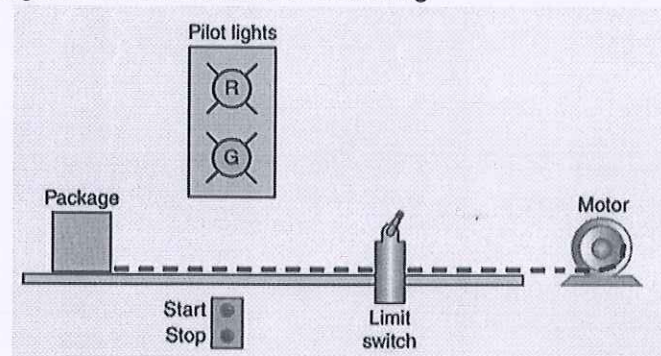



Answer Key Set – A

Course Code: ELE 1301, Course Name: Automation & Control
School of Electrical Skills, Session: 2020-21 (Summer Semester)
B. Voc. Program, 3rd Semester, End-Sem. Examination

Section – A

1. (d) C(AB + D)
2. (c) Normally-open contacts in parallel
3. (c) LOW inputs and HIGH outputs
4. (a) poor than
5. (d) All of the above
6. (c) Both (A) & (B)
7. (b) normally closed type
8. (c) RST instruction with timer address must be true.
9. (d) MOV
10. (b) Supervisory Control and Data Acquisition

Section – B

1. PLCs operate by continually scanning programs and repeat this process many times per second. When a PLC starts, it runs checks on the hardware and software for faults, also called a self-test. If there are no problems, then the PLC will start the scan cycle. The scan cycle consists of three steps: input scan, executing program(s), and output scan.

Input Scan: A simple way of looking at this is the PLC takes a snapshot of the inputs and solves the logic. The PLC looks at each input card to determine if it is ON or OFF and saves this information in a data table for use in the next step. This makes the process faster and avoids cases where an input changes from the start to the end of the program.

Execute Program (or Logic Execution): The PLC executes a program one instruction at a time using only the memory copy of the inputs the ladder logic program. For example, the program has the first input as ON. Since the PLC knows which inputs are ON/OFF from the previous step, it will be able to decide whether the first output should be turned ON.

Output Scan: When the ladder scan completes, the outputs are updated using the temporary values in memory. The PLC updates the status of the outputs based on which inputs were ON during the first step and the results of executing a program during the second step. The PLC now restarts the process by starting a self-check for faults.

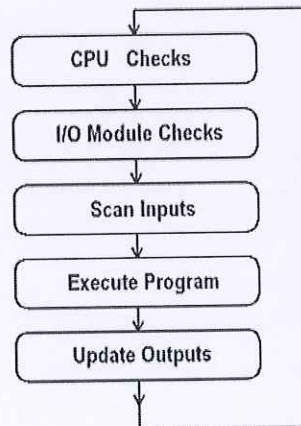

2. *Fixed Automation:* It is used in high volume production with dedicated equipment, which has a fixed set of operation and designed to be efficient for this set. Continuous flow and Discrete Mass Production systems use this automation. e.g. Distillation Process, Conveyors, Paint Shops, Transfer lines etc.

A process using mechanized machinery to perform fixed and repetitive operations in order to produce a high volume of similar parts.

Advantages:



Answer Key Set – A

Course Code: ELE 1301, Course Name: Automation & Control
School of Electrical Skills, Session: 2020-21 (Summer Semester)

B. Voc. Program, 3rd Semester, End-Sem. Examination

- (a) Low unit cost
- (b) Automated material handling
- (c) High production rate.

Disadvantages:

- (a) High initial Investment
- (b) Relatively inflexible in accommodating product changes.

Programmable Automation: It is used for a changeable sequence of operation and configuration of the machines using electronic controls. However, non-trivial programming effort may be needed to reprogram the machine or sequence of operations. Investment on programmable equipment is less, as production process is not changed frequently. It is typically used in Batch process where job variety is low and product volume is medium to high, and sometimes in mass production also. e.g. in Steel Rolling Mills, Paper Mills etc.

Advantages:

- (a) Flexible to deal with design variations.
- (b) Suitable for batch production.

Disadvantages:

- (a) High investment in general purpose equipment
- (b) Lower production rate than fixed automation.

3.

Ladder logic symbols	Description
	Load/AND contact
	Load NOT/AND NOT contact
	OR contact
	OR NOT contact
	Output coil
	Inverted output coil
	Rising/Positive edge contact
	Falling/Negative edge contact
	Set coil or bit
	Reset coil or bit
	Timer
	Counter

4. Simple Timers

A timer is simply a control block that takes an input and changes an output based on time. There are two basic timer types we will deal with initially (there are other advanced timers, but we will start with the basics first) – On-Delay Timer and the Off-Delay Timer.

On-Delay Timer - this timer takes an input, waits a specific amount of time, then turns ON an output (or allows logic to flow after the delay).

Off-Delay Timer – this timer takes turns ON an output (or allows logic to flow) and keeps that output ON until the set amount of time has passed, then turns it OFF (hence off-delay)

Simple Counter

Answer Key Set – A



Course Code: ELE 1301, Course Name: Automation & Control
School of Electrical Skills, Session: 2020-21 (Summer Semester)
B. Voc. Program, 3rd Semester, End-Sem. Examination

A counter simply counts the number of events that occur on an input. There are two basic types of counters – Up counter and a Down counter.

Up Counter – as its name implies, whenever a triggering event occurs, an up counter increments the counter.

Down Counter - whenever a triggering event occurs, a down counter decrements the counter.

Section – C

1. Counter in PLC- A PLC counter is a function block that counts up or down until it reaches a limit. When the limit is reached the output is set. The thing is that counting is in fact widely used in PLC programming. Often you will have the need to counts different things. An example of this could be to keep track of how many times a process has been completed. Or how many products has been produced. PLC counters are also used to assist logging to SCADA systems by counting the amount of times these events has happened or setting alarms when an event has happened a certain amount of times. There are two types of Counters

a). UP- Counter: Count Up(CTU)- This output instruction counts up for each false-to-true transition of conditions preceding it in the rung and produces an output when the accumulated value reaches the preset value. Rung transitions might be triggered by a limit switch or by parts traveling past a detector. The ability of the counter to detect false-to-true transitions depends on the speed (frequency) of the incoming signal. The on and off duration of an incoming signal must not be faster than the scan time. Each count is retained when the rung conditions again become false, permitting counting to continue beyond the preset value. This way you can base an output on the preset but continue counting to keep track of inventory/parts, etc.

b). Down- Counter: Count Down(CTD)- This output instruction counts down for each false-to-true transition of conditions preceding it in the rung and produces an output when the accumulated value reaches the preset value. Rung transitions might be triggered by a limit switch or by parts traveling past a detector. Each count is retained when the rung conditions again become false. The count is retained until a RES (reset) instruction with the same address as the counter is enabled, or if another instruction in your program overwrites the value. The accumulated value is retained after the CTU or CTD instruction goes false, and when power is removed from and then restored to the processor. Also, the on or off status of counter done, overflow, and underflow bits is retentive. The accumulated value and control bits are reset when a RES is enabled.

c). Reset Instruction (RES)- The RES instruction is used to reset timers and counters. When conditions preceding it in the rung are true, the RES resets the accumulated value and control bits of the timer or counter. Make sure that the timer or counter being controlled by the reset instruction has the same address as the reset instruction. For example, if your RTO address is T4:1, your RES address must also be T4:1. When resetting a counter, if the RES instruction is enabled and the counter rung is enabled, the CU or CD bit is reset. If the counter preset value is negative, the RES instruction sets the accumulated value to zero. This causes the done bit to be set by a count down or count up instruction.

2. For a PLC to monitor and in turn control its application variables, there must be a way for it to sense its surroundings. In today's industrial realm, there are a huge variety of electrical sensors that provide the input data (position, distance, level, flow, etc.) that control systems need.



Answer Key Set – A

Course Code: ELE 1301, Course Name: Automation & Control
School of Electrical Skills, Session: 2020-21 (Summer Semester)

B. Voc. Program, 3rd Semester, End-Sem. Examination

- a. Push buttons are the ones that you will usually see as START or STOP buttons in a PLC control system. It operates by either MAKING contact (Make) or by BREAKING contact (Break). Hence, pushbuttons are divided into two categories: Normally open or Normally closed.
- b. Limit switches, as the name implies, change state when a predetermined limit is reached. These are actually useful in automation because you can set a limit (using the limit switch) where a specific process stops.
- c. Analog sensors are devices that output a continuous voltage linear to the experienced change in the environment. They are most extensively used in Temperature Sensing, Distance Sensing, Luminance Sensing, Pressure Sensing, and basically in PLC applications where an exact, certain unit of measure is involved.
- d. Discrete sensors, on the other hand, outputs a HIGH or a LOW voltage only. This is derived from the Binary number system where the only possible digits are 0 and 1—which can represent LOW and HIGH, respectively.
- e. Proximity Sensor- Proximity Sensors, in PLC automation, are usually used in detecting the presence or absence of objects made of varying materials. They do so WITHOUT making contact. Sometimes they are called “proximity switches” because the output is binary, HIGH or LOW—just like a switch.

Magnetic reed switch- The reed switch consists of two ferromagnetic material sealed in glass or plastic. The two materials do not initially touch each other, but when a magnetic field from either a permanent magnet or an induced one (from a current-carrying coil) is placed near the reed switch, the switch closes and makes electrical continuity.

Photoelectric- Photoelectric sensors use a light emitting diode as an emitter, and usually phototransistors or photodiodes at the receiver side. Basically, when the light (usually infrared) from the emitter's LED hits the receiver, the sensor changes state from LOW to HIGH.

Ultrasonic- Ultrasonic Sensors uses sound waves and their reflection in order to detect the presence of an object. Obviously, objects that absorb sound are incapable of being detected by ultrasonic sensors.

3.

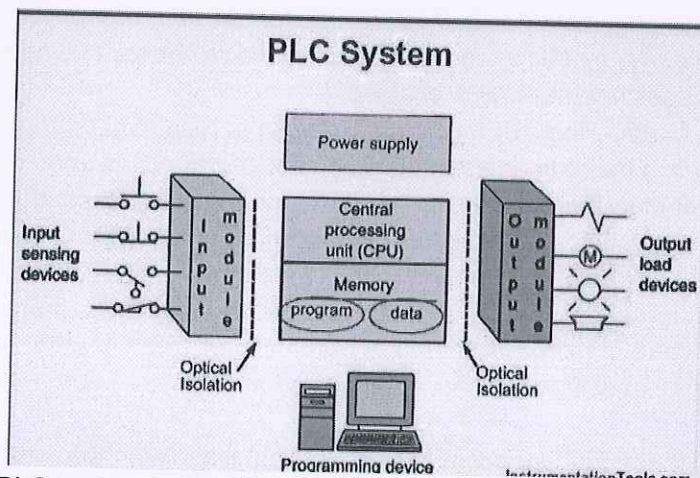

The heart of the PLC system is the CPU (Central Processing Unit). It is made up of a control unit and processor. The CPU control unit manages the interaction between the various PLC hardware components while the CPU processor handles all the number crunching and program (e.g. ladder logic) execution.

Answer Key Set – A



Course Code: ELE 1301, Course Name: Automation & Control
School of Electrical Skills, Session: 2020-21 (Summer Semester)
B. Voc. Program, 3rd Semester, End-Sem. Examination

Data flow is from the input devices, through the CPU processor and then to the output devices. The CPU processor also exchanges data with the program and data memory. Once all the data is gathered the program (e.g. ladder logic) is processed in a cyclic fashion. The resulting data flows to the output interface for conditioning and execution of the output devices. The CPU also controls and exchanges data with the communication interface and devices. An addressing system is used for data organization that is shared between the various hardware components.

A programming terminal is used to formulate the PLC program (e.g. ladder logic), load the program into the controller and monitor/control the PLC and its program.

The power supply is responsible for supplying and managing the power requirements of the various PLC hardware components.

4.

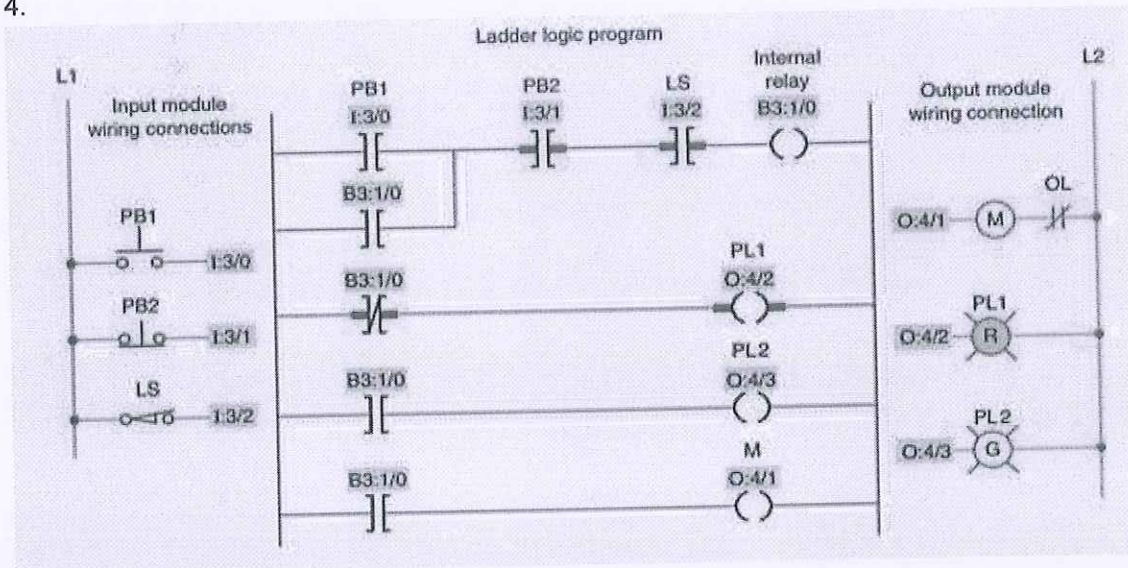



School of Electrical Skills

Session: 2020-21 (Summer Semester)

B. Voc. Program, 3rd Semester,

End-Sem. Examination

Course Code: ELE 1301

Time: 2 Hours

Course Name: Automation & Control

Max. Marks: 50

Instruction: Answer all questions from section A, each question carries one mark. Answer all questions from section B, each question carries four marks. Answer all questions from section C, each question carries six marks. Scientific calculator is allowed.

Section – A

10X01 = 10 Marks

1. The Boolean representation of this PLC program is:

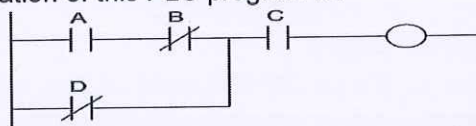

- (a) $C + (A + B)D$
(c) $ABC + BD$

- (b) $C + D(A + B)$
(d) $C(AB + D)$

2. Which of the following is not a comparison instruction?

- (a) GEQ
(c) LIM

- (b) EQU
(d) MOV

3. When _____ contacts are actuated, they disrupt the power supply through them.

- (a) normally open type
(c) both a. and b.

- (b) normally closed type
(d) none of these

4. The NAND gate is AND gate followed by

- (a) NOT gate
(c) AND gate

- (b) OR gate
(d) None of these

5. PLC can be _____ in plant to change the sequence of operation.

- (a) only programmed
(c) programmed and reprogrammed

- (b) only reprogrammed
(d) able to give a set point

6. From which of the following is type of control system.

- (a) Closed loop control system
(c) Both (A) & (B)

- (b) Open loop control system
(d) None of these

7. When an input signal 1 is applied to a NOT gate, the output is

- (a) 0
(c) Either 0 & 1

- (b) 1
(d) None of the above

8. To reset the time for a PLC what condition must be true?

- (a) Reset rung of TON must be true.
(b) Reset rung of TON must be false.
(c) RST instruction with timer address must be true.
(d) RST instruction with associated timer address must be false.

9. An OR function implemented in ladder logic uses:

- (a) Normally-open contacts in series
(b) A single normally-closed contact
(c) Normally-open contacts in parallel
(d) Normally-closed contacts in parallel

Answer Key Set – B



Course Code: ELE 1301, Course Name: Automation & Control
School of Electrical Skills, Session: 2020-21 (Summer Semester)
B. Voc. Program, 3rd Semester, End-Sem. Examination

Section – A

1. (d) C(AB + D)
2. (d) MOV
3. (b) normally closed type
4. (a) NOT gate
5. (c) programmed and reprogrammed
6. (c) Both (A) & (B)
7. (a) 0
8. (c) RST instruction with timer address must be true.
9. (c) Normally-open contacts in parallel
10. (b) normally closed type

Section – B

1. PLCs operate by continually scanning programs and repeat this process many times per second. When a PLC starts, it runs checks on the hardware and software for faults, also called a self-test. If there are no problems, then the PLC will start the scan cycle. The scan cycle consists of three steps: input scan, executing program(s), and output scan.

Input Scan: A simple way of looking at this is the PLC takes a snapshot of the inputs and solves the logic. The PLC looks at each input card to determine if it is ON or OFF and saves this information in a data table for use in the next step. This makes the process faster and avoids cases where an input changes from the start to the end of the program.

Execute Program (or Logic Execution): The PLC executes a program one instruction at a time using only the memory copy of the inputs the ladder logic program. For example, the program has the first input as ON. Since the PLC knows which inputs are ON/OFF from the previous step, it will be able to decide whether the first output should be turned ON.

Output Scan: When the ladder scan completes, the outputs are updated using the temporary values in memory. The PLC updates the status of the outputs based on which inputs were ON during the first step and the results of executing a program during the second step. The PLC now restarts the process by starting a self-check for faults.

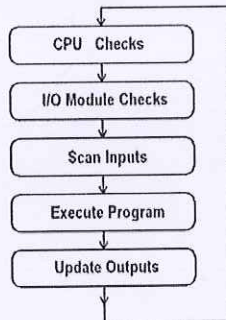

2. PROGRAMMABLE LOGIC CONTROLLER (PLC)- It is an industrial computer control system which is used to control machines and processes. It continuously monitors the state of input devices (proximity sensors, limit switches etc.) and processes it, in order to control the state of output devices (valves, actuators, solenoids etc).

Following are the key features of PLC: –

- (a) PLC generally work only in automated mode. If there is any kind of error during the operation, the operation cannot proceed till it recites or corrected.
- (b) The set point predefined in PLC cannot be altered and needs a licensed program in order to make changes.
- (c) In PLC system, there is no display unit due to which we cannot monitor what is going on during the execution of a process

HUMAN MACHINE INTERFACE (HMI): – It is a component of a device that allows interaction between human operators and machine. By using this component, operator controls or



Answer Key Set – B

Course Code: ELE 1301, Course Name: Automation & Control

School of Electrical Skills, Session: 2020-21 (Summer Semester)

B. Voc. Program, 3rd Semester, End-Sem. Examination

operate the process by interacting with supervisory system. Process can be graphically visualized by using it. Following are the key features of HMI: –

- (a) HMI work in both auto and manual mode. If there is any error during a process, it can be turned to manual mode to ensure the continuity of the operations
- (b) Unlike PLC, the set points for HMI are not predefined. Therefore, they can be changed as per requirement.
- (c) HMI always consists of display unit with function buttons to control or operate a process which makes user able to monitor or control the undergoing process.
- (d) HMI is generally a touch screen to the PLC.

SUPERVISORY CONTROL AND DATA ACQUISITION (SCADA) – It is an integrated system that is used to control and monitor the working of the individual parts of the plant. It helps in management of automation of large and complex processes. They are used to perform data collection and control at supervisory level.

The SCADA system consists of following components: –

- (a) Supervisory computers– This is the heart of the SCADA system, which collects the data from the ongoing process and sending
- (b) control commands to the eld connected devices.
- (c) Remote terminal units– Also known as (RTUs), these are connected to sensors and actuators in the process, and are networked to
- (d) the supervisory computer system.
- (e) Programmable logic controllers (PLC)- These are connected to supervisory computer system in the same way as RTUs but they are
- (f) often use than RTUs as they are economical and versatile.
- (g) Communication infrastructure– It connects the supervisory computer system to RTUs and PLC. During an error in communication system like in case of power failure the process of plant didn't hamper and on resumption of power a person can continue the process.
- (h) Human machine interface-HMI is the graphical user interface for the operator, collects all data from external devices, creates reports, performs alarming, sends notifications, etc.

3.

Ladder logic symbols	Description
	Load/AND contact
	Load NOT/AND NOT contact
	OR contact
	OR NOT contact
	Output coil
	Inverted output coil
	Rising/Positive edge contact
	Falling/Negative edge contact
	Set coil or bit
	Reset coil or bit
	Timer
	Counter

Answer Key Set – B



Course Code: ELE 1301, Course Name: Automation & Control
School of Electrical Skills, Session: 2020-21 (Summer Semester)
B. Voc. Program, 3rd Semester, End-Sem. Examination

4. Advantages of Programmable logic controller (PLC) control:

- (a) Rugged and designed to withstand vibrations, temperature, humidity, and noise
- (b) Have interfacing for inputs and outputs already inside the controller.
- (c) PLCs are easily programmed and have an easily understood programming language.

Disadvantages of Programmable logic controller (PLC, programmable controller):

- (a) There's too much work required in connecting wires
- (b) There's difficulty with changes or replacements.
- (c) It's always difficult to find errors; And require skillful work force.
- (d) When a problem occurs, hold-up time is indefinite, usually long.

Section – C

1. Counter in PLC- A PLC counter is a function block that counts up or down until it reaches a limit. When the limit is reached the output is set. The thing is that counting is in fact widely used in PLC programming. Often you will have the need to counts different things. An example of this could be to keep track of how many times a process has been completed. Or how many products has been produced. PLC counters are also used to assist logging to SCADA systems by counting the amount of times these events has happened or setting alarms when an event has happened a certain amount of times. There are two types of Counters

a). UP- Counter: Count Up(CTU)- This output instruction counts up for each false-to-true transition of conditions preceding it in the rung and produces an output when the accumulated value reaches the preset value. Rung transitions might be triggered by a limit switch or by parts traveling past a detector. The ability of the counter to detect false-to-true transitions depends on the speed (frequency) of the incoming signal. The on and off duration of an incoming signal must not be faster than the scan time. Each count is retained when the rung conditions again become false, permitting counting to continue beyond the preset value. This way you can base an output on the preset but continue counting to keep track of inventory/parts, etc.

b). Down- Counter: Count Down(CTD)- This output instruction counts down for each false-to-true transition of conditions preceding it in the rung and produces an output when the accumulated value reaches the preset value. Rung transitions might be triggered by a limit switch or by parts traveling past a detector. Each count is retained when the rung conditions again become false. The count is retained until a RES (reset) instruction with the same address as the counter is enabled, or if another instruction in your program overwrites the value. The accumulated value is retained after the CTU or CTD instruction goes false, and when power is removed from and then restored to the processor. Also, the on or off status of counter done, overflow, and underflow bits is retentive. The accumulated value and control bits are reset when a RES is enabled.

c). Reset Instruction (RES)- The RES instruction is used to reset timers and counters. When conditions preceding it in the rung are true, the RES resets the accumulated value and control bits of the timer or counter. Make sure that the timer or counter being controlled by the reset instruction has the same address as the reset instruction. For example, if your RTO address is T4:1, your RES address must also be T4:1. When resetting a counter, if the RES instruction is enabled and the counter rung is enabled, the CU or CD bit is reset. If the counter preset value is negative, the RES instruction sets the accumulated value to zero. This causes the done bit to be set by a count down or count up instruction.

2 Types of production systems

Major industrial processes can be categorized as follows based on their scale and scope of production.

a) Unit or Job type of production: This type of production is most commonly observed when you produce one single unit of a product. A typical example of the same will be tailored outfits which are made just for you or a cake which is made just like you want it.



Answer Key Set – B

Course Code: ELE 1301, Course Name: Automation & Control

School of Electrical Skills, Session: 2020-21 (Summer Semester)

B. Voc. Program, 3rd Semester, End-Sem. Examination

Example of Unit type of production- It is one of the most common types of products used because it is generally used by small businesses like restaurants, individual products providers or individual services providers. It is also a type of production used by very premium companies like Harley Davidson, or Dell. Harley Davidson actually has a lot of accessories which can be customized, and which suit the individual. Same ways, you can design your own DELL laptop on their website with the given specifications. Features of Unit production or Job Production

- Depends a lot on skill
- Dependency is more on manual work than mechanical work
- Customer service and customer management plays an important role

b) Batch type of Production It is one of the types of production most commonly used in consumer durables, FMCG or other such industries where there are large variety of products with variable demands. Batch production takes place in batches. The manufacturer already knows the number of units he needs to a manufacturer and they are manufactured in one batch. So, if a manufacturer has the shortage of Product X and 100 units of this product is consumed in one month, then the manufacturer can give orders for batch production of 100 units of Product X. Example of Batch production- LG has many different types of home appliance products in its portfolio. It has to manufacture all these different variants of the same type of product. There would be 10-20 types of mixer grinders alone in the product portfolio of LG home appliances. Thus, a company like LG manufactures these variants via Batch production. First, one type of mixer will be manufactured completely and then the second type will be manufactured. They are manufactured on the basis of demand. Depending on demand, the batch production can produce the number of units required in one batch. The batches may be as small as 10 units or they may be as large as 1 lakh units of the same products. However, as long as there is a defined quantity of product which has to be manufactured before moving on to the next item in the list, it is known as batch production. Examples of batch production include FMCG like Biscuits, confectionaries, packaged food items etc. It is used in Medicines, Hardware, Consumer durables and many such industries. Features of Batch production

- Production is done in batches
- The total number of units required is decided before the batch production starts
- Once a batch production starts, stopping it midway may cost a huge amount to the company.
- Demand plays a major role in a batch production. Example – seasonality of products.

c) Mass Production or Flow production: One of the best examples of mass production is the manufacturing process adopted by Ford. Mass production is also known as flow production or assembly line production. It is one of the most common types of products used in the automobile industry and is also used in industries where continuous production is required. An Assembly line or mass production plant typically focus on specialization. There are multiple workstations installed and the assembly line goes through all the workstations turn by turn. The work is done in a specialized manner and each workstation is responsible for one single type of work. As a result, these workstations are very efficient and production due to which the whole assembly line becomes productive and efficient. Products which are manufactured using mass production are very standardized products. High sophistication is used in the manufacturing of these products. If 1000 products are manufactured using mass production, each one of them should be exactly the same. There should be no deviation in the product manufactured. Features of Mass Production

- Mass production is generally used to dole out huge volumes of the product
- It is used only if the product is standardized
- Demand does not play a major role in a Mass production. However, production capacity determines the success of a mass production.
- Mass production requires huge initial investment and the working capital demand is huge too.

d) Continuous production or Process production: There is a lot of confusion between mass production and continuous production. It can be differentiated by a single element. The amount of mechanical work involved. In Mass production, both machines and humans work

Answer Key Set – B



Course Code: ELE 1301, Course Name: Automation & Control
School of Electrical Skills, Session: 2020-21 (Summer Semester)
B. Voc. Program, 3rd Semester, End-Sem. Examination

in tandem. However, in continuous production, most of the work is done by machines rather than humans. In continuous production, the production is continuous, 24×7 hours, all days in a year. A good example of the Continuous production is brewing. In brewing, the production goes on 24 hours a day and 365 days a year. This is because brewing takes a lot of time and production is important. As a result, there is a continuous input of raw materials such as malt or water, and there is continuous output in the form of beer or other alcoholic drink. The key factor in this is that the brewing and fermentation process itself is time-consuming, and the maximum time is spent in the fermentation which is a continuous process. There are many chemicals which are manufactured in the form of a continuous process due to the huge demand across the world. Similarly, the Plastic industry is known to adopt the continuous production methodology where production can go continuously for weeks or months depending on the demand. Once the production starts, you only need to feed in the raw material, and the machines turn out the finalized products. Features of Continuous production

- Majority of the work is done by machines rather than humans
- Work is continuous in nature. Once production starts, it cannot be stopped otherwise it will cause huge loss.

3.

EQU	Equal	Test whether two values are equal
NEQ	Not Equal	Test whether one value is not equal to a second value
LES	Less Than	Test whether one value is less than a second value
LEQ	Less Than or Equal	Test whether one value is less than or equal to a second value
GRT	Greater Than	Test whether one value is greater than another
GEQ	Greater Than or Equal	Test whether one value is greater than or equal to a second value
MEQ	Masked Comparison for Equal	Test portions of two values to see whether they are equal. Compares data through a mask
LIM	Limit Test	Test whether one value is within the limit range of two other values

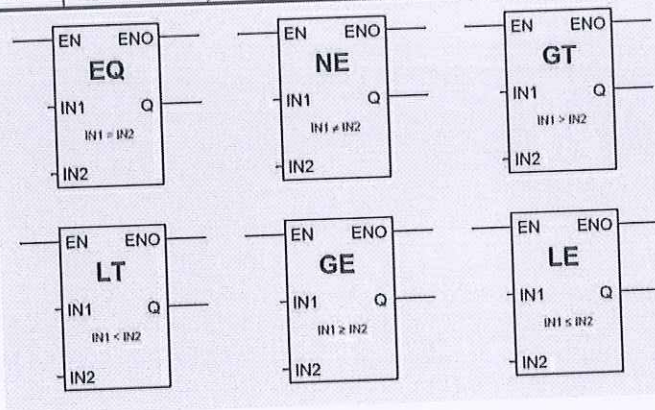

4.

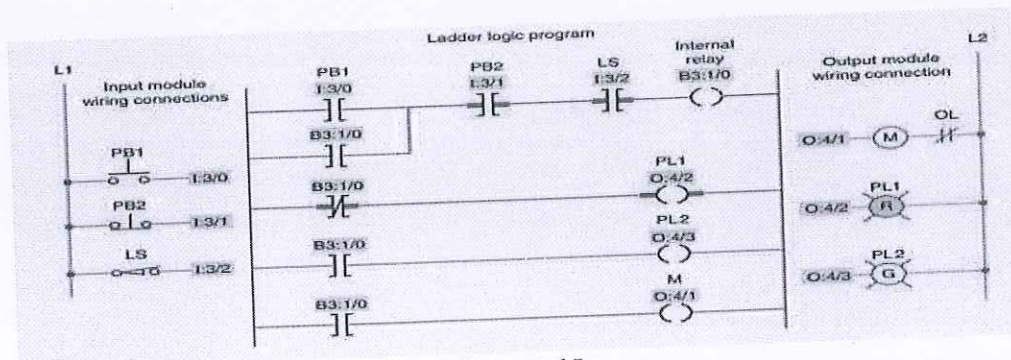



BHARTIYA SKILL DEVELOPMENT UNIVERSITY

Registration No.:

School of Electrical Skills
Session: 2020-21 (Summer Semester)
B. Voc. Program, 3rd Semester
End-Sem. Examination

Course Code: ELE1302

Time: 2 Hours

Course Name: Electrical Machine-I

Max. Marks: 50

Instruction: Answer all questions from section A, each question carries one mark. Answer all questions from section B, each question carries four marks. Answer all questions from section C, each question carries six marks. Scientific calculator is allowed.

Section – A

10X01 = 10 Marks

1. The normal value of the armature resistance (in ohms) of a D.C. motor is:
(a) .005 (b) 0.5 (c) 10 (d) 100
2. If the pole flux of a DC motor approached zero, its speed will:
(a) Approach zero (b) Not change (c) Be very high (d) Approach a stable value
3. Sumpner's test used to calculate:
(a) Copper losses (b) Core & Copper losses both (c) Core losses (d) None of these
4. No. of Parallel paths in Lap winding:
(a) = 2 (b) = no. of poles (c) = 3 (d) = 4
5. Power Transformer are designed to have maximum efficiency at:
(a) Full load (b) 75% load (c) 50% load (d) No load
6. For maximum efficiency of transformer:
(a) Core loss must be high (b) Core loss = Copper loss (c) Copper loss must be high (d) None of these
7. Turns ratio of transformer:
(a) $N_1 \cdot V_1 / N_2 \cdot V_2$ (b) N_1 / N_2 (c) I_1 / I_2 (d) None of these
8. Full form of BLDC motor:
(a) Brush Lower Direct Current (b) Blower Less Direct Current (c) Brush Less Direct Current (d) None of these
9. Rating of Transformer is in:
(a) KW (b) KVA (c) KVAR (d) Watt
10. Commutator is used in:
(a) DC Generator (b) DC Motor (c) Both (a) & (b) (d) None of these

Section – B

04X04 = 16 Marks

1. Explain in brief about the following with diagrams:
(a) Open circuit test of transformer (b) Short Circuit test of Transformer
2. Explain the principle of DC generator with diagrams and waveform.
3. List the details available on the plate fixed on the transformer.

Joan lab
A

4. What is the need of the starter for starting DC motor?

Section – C

04X06 = 24 Marks

1. A 400 kVA transformer has a primary winding resistance of 0.5 ohm and a secondary winding resistance of 0.001 ohm. The iron loss is 2.5 Kw and the primary and secondary voltages are 5 kV and 320 V respectively. If the power factor of the load is 0.85, determine the efficiency of the transformer on full load.
2. Explain the protection of transformer by Buchholz relay.
3. A 220-V DC machine has an armature resistance of 0.5 Ω . If the full-load armature current is 20 A, find the induced e.m.f. when the machine acts as (a) generator (b) motor. Assume current flowing in the shunt field is zero.

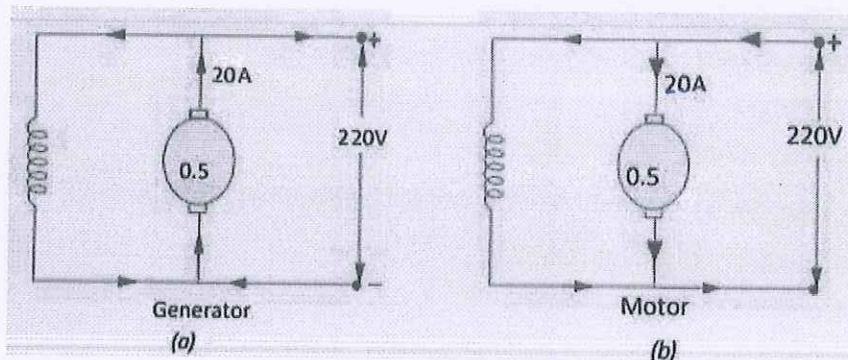

4. Develop Simplex progressive lap winding 24 conductors & 4 poles.



(Ans. Key ELE 1302 Set – A)

BHARTIYA SKILL DEVELOPMENT UNIVERSITY

School of Electrical Skills
Session: 2020-21 (Summer Semester)
B. Voc. Program, 3rd Semester
End-Sem. Examination

Course Code: ELE1302

Course Name: Electrical Machine-I

Time: 2 Hours

Max. Marks: 50

Answer Key

Section-A

1. B
2. C
3. C
4. B
5. A
6. B
7. B
8. C
9. B
10. C

Section-B

1. A) Open Circuit test on Transformer:

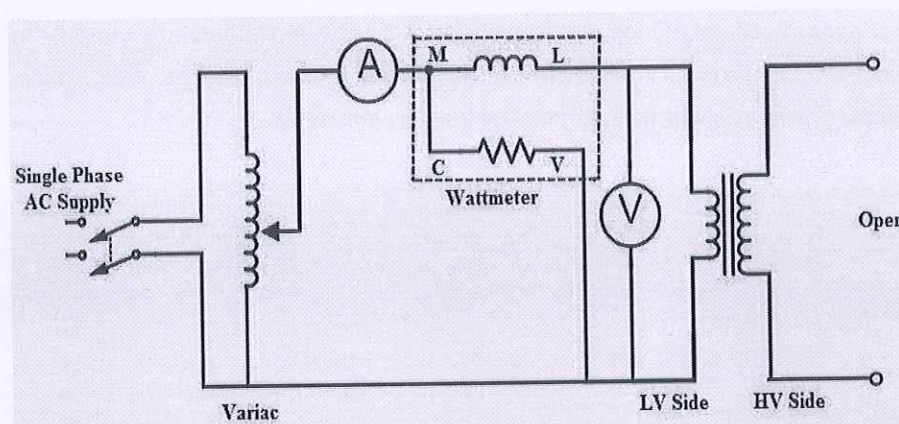

The main purpose of this test is to find the iron loss and no load current which are useful in calculating core loss resistance and magnetizing reactance of the transformer. In open circuit test primary winding is connected to A C supply, keeping secondary open. Sometimes a voltmeter may be connected across secondary as voltmeter resistance is very high & voltmeter current is negligibly small so that secondary is treated as open circuit. Usually low voltage side is used as primary and high voltage side as secondary to conduct Open circuit test.

When primary voltage is adjusted to its rated value with the help of auto transformer, readings of ammeter and wattmeter are to be recorded. Ammeter gives no load current. Transformer no load current is always very small, 2 to 5 % of its full load current. As secondary is open, $I_2 = 0$, hence secondary copper losses are zero. And $I_1 = I_0$ is very low hence copper losses on primary are also very low. Thus

BHARTIYA SKILL DEVELOPMENT UNIVERSITY



the total copper losses in open circuit test are negligibly small, hence neglected. Therefore, the wattmeter reading in Open circuit test gives iron losses which remain constant for all the loads.

B) Short Circuit Test on transformer:

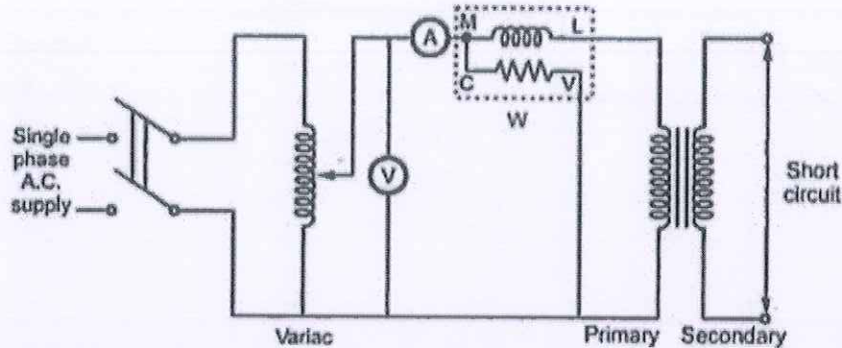

The main purpose of this test is to find full load copper loss and winding parameters which are helpful for finding regulation of transformer. In this test, secondary is short circuited with the help of ammeter. (secondary may be short circuited with thick copper wire or solid link). As secondary is shorted, its resistance is very small and on rated voltage it may draw very large current. Such large current can cause overheating and burning of the transformer. To limit this short circuit current, primary is supplied with low/reduced voltage (2 - 5% of the rated voltage) which is just enough to cause rated current to flow through primary which can be observed on an ammeter. The reduced voltage can be adjusted with the help of auto transformer. The wattmeter reading as well as voltmeter, ammeter readings are recorded. As the voltage applied is low which is a small fraction of the rated voltage and iron losses are function of applied voltage, hence iron losses are negligibly small. Since the currents flowing through the windings are rated currents hence the total copper loss is full load copper loss. Hence the wattmeter reading is the power loss which is equal to full load copper losses.

2.

Principle of Generator :- [Faraday's law of electro-magnetic induction]
Consider a simple coil rotating b/w north & south poles at position 1 & 5 conductors rotation is quite parallel to the flux lines. Therefore there is no rate of change of flux linkage consequently induced emf is zero.
Axis along position (1) & (5) is known as (MNA) Magnetic Neutral axis which is always 90° with the flux lines.



At position 3 & 7 conductors rotation is quite \perp to the flux lines. So max. emf will induced in it for one complete mechanical rotation which is periodic in nature known as alternating voltage.

With the help of commutator AC can be converted into DC.

We know that, when conductor

Angle	$\sin \theta$	emf, e
0°	0	0
90°	1	Blv
180°	0	0
270°	-1	$-Blv$
360°	0	0

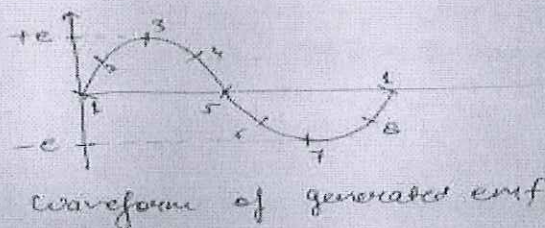



3. Details on the Plate fixed on the Transformer
1. Single/Three Phase transformer
 2. KVA rating
 3. HV winding Voltage
 4. HV winding Current
 5. LV winding Voltage
 6. LV winding Current
 7. Losses in watts– at Full load, at Half load
 8. Vector Group (how the primary and secondary windings are connected and also about whether Neutral is earthed or not earthed)
 9. % Impedance or Impedance Voltage (It is the supply voltage as a percentage of rated voltage, that is required to circulate the rated current through the transformer, keeping the other side of the transformer winding short circuited)
 10. Serial No of Transformer
 11. Date/Year of manufacturing
 12. Volume and weight of the Cooling oil if used
 13. Permissible rise in temperature of the oil and windings under loaded conditions
 14. Customer (If made to order)
 15. Order No and date (if made to order)
 16. Total weight of the transformer
 17. The standards it complies for manufacturing (IS:1180 etc.)

4. When the DC motor is at rest, there is no back EMF in the armature. At that time, when the DC voltage is applied to the armature a huge amount of current flows in the armature as the armature resistance is very low. This high value of current in the armature can cause serious damage to the armature of the DC motor. To avoid this, a starter is used to start the DC motor in which a certain value of resistance (For Resistance Starter) is inserted in series with the armature, which is gradually reduced. When the motor fully picks up the speed, the resistance is fully removed from the circuit and the motor works as desired. The rate at which the resistance in the armature circuit is reduced depends upon the rate at which the back EMF in the motor increases. The main aim being to limit the starting current to avoid damage to the motor.

Section-C

1. A 400 kVA transformer has a primary winding resistance of 0.5 ohm and a secondary winding resistance of 0.001 ohm. The iron loss is 2.5 Kw and the primary and secondary voltages are 5 kV and 320 V respectively. If the power factor of the load is 0.85, determine the efficiency of the transformer on full load.

Solution

Rated output = 400 kVA = 400×10^3 kVA

Full load secondary current, $I_2 = \text{Rated output}/V_2 = 1250$ A



Total resistance referred to secondary, $r_{e2} = r_2 + r_1(V_2/V_1)^2 = 0.033$ -ohm Full load copper loss, $P_c = I_2^2 r_{e2} = 51.5625$ Kw

Iron loss, $P_i = 2.5 \times 10^3$ watts

Transformer efficiency at full load and 0.85 pf

$$\eta = \frac{x V_2 I_2 \cos \theta_2}{x V_2 x_2 \cos \theta_2 + P_i + P_c} \times 100$$
$$= 86.2\%$$

= 86.2%

2. Working of Buchholz relay:

- The **Buchholz relay working principle** of is very simple. **Buchholz relay function** is based on very simple mechanical phenomenon. It is mechanically actuated. Whenever there will be a minor internal fault in the transformer such as an insulation fault between turns, breakdown of core of the transformer, core heating, the insulating transformer oil will be decomposed in different hydrocarbon gases, CO₂ and CO. The gases produced due to the decomposition of transformer insulating oil will accumulate in the upper part the Buchholz container which causes fall of oil level in it.
- Fall of oil level means lowering the position of the float and thereby tilting the mercury switch. The contacts of this mercury switch are closed and an alarm circuit energized. Sometimes due to oil leakage on the main tank air bubbles may be accumulated in the upper part of the Buchholz container which may also cause a fall of oil level in it and the alarm circuit will be energized. By collecting the accumulated gases from the gas release pockets on the top of the relay and by analysing them one can predict the type of fault in the transformer.
- More severe types of faults, such as short circuit between phases or to earth and faults in the tap changing equipment, are accompanied by a surge of oil which strikes the baffle plate and causes the mercury switch of the lower element to close.

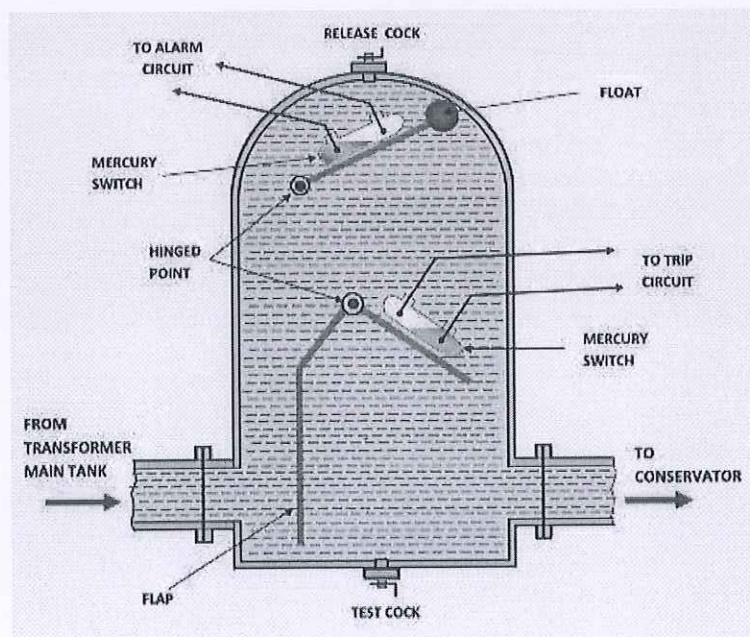



- This switch energized the trip circuit of the circuit breakers associated with the transformer and immediately isolate the faulty transformer from the rest of the electrical power system by inter tripping the circuit breakers associated with both LV and HV sides of the transformer. This is how Buchholz relay functions.

3.

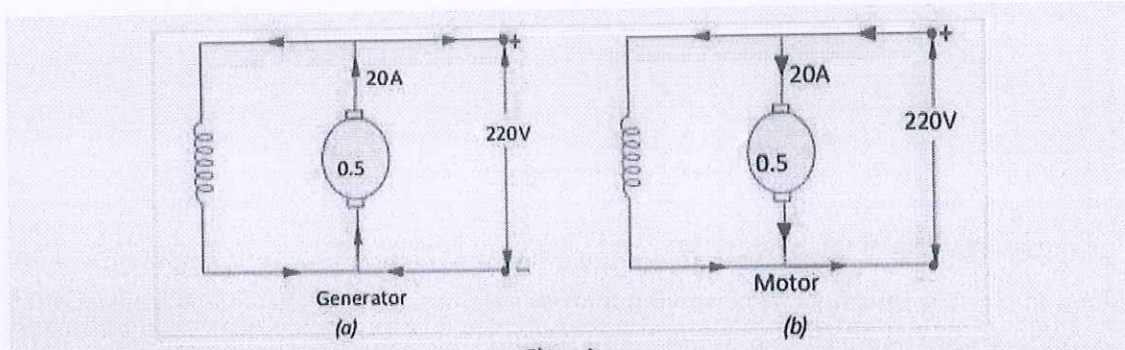

Fig. - 1

Solution. As shown in Fig. 1, the DC machine is shunt-connected. In each case, shunt current is zero as given in the question.

- (a) As Generator [Fig. 1 (a)] $E_g = V + I_a R_a = 220 + 0.5 \times 20 = 230 \text{ V}$
 (b) As Motor [Fig 1 (b)] $E_b = V - I_a R_a = 220 - 0.5 \times 20 = 210 \text{ V}$

4.

Pole pitch = $\frac{Z}{P} = \frac{24}{4} = 6 \text{ slots/pole}$

Avg-pitch ; $\left[\gamma_n = \frac{\gamma_b + \gamma_f}{2} = \frac{Z}{P} \right] \Rightarrow \text{Lap winding}$

$\frac{\gamma_b + \gamma_f}{2} = 6$

$\gamma_b + \gamma_f = 12 \quad \text{--- (1)}$

$\left[\gamma_b - \gamma_f = 2M \right] \rightarrow \text{multiplicity factor}$

$M = 1 \text{ for simplex}$

$\gamma_b - \gamma_f = 2 \quad \text{--- (2)}$

$\gamma_b = \frac{14}{2} = 7 \quad \& \quad \gamma_f = 5$

<p>1st coil side $\gamma_b = 7$</p> <p>1st coil side \downarrow</p> <p>1 + 7 = 8</p> <p>3 + 7 = 10</p> <p>5 + 7 = 12</p> <p>7 + 7 = 14</p> <p>9 + 7 = 16</p> <p>11 + 7 = 18</p>	<p>1st coil side $\gamma_f = 5$</p> <p>1st coil side \downarrow</p> <p>8 - 5 = 3</p> <p>10 - 5 = 5</p> <p>12 - 5 = 7</p> <p>14 - 5 = 9</p> <p>16 - 5 = 11</p> <p>18 - 5 = 13</p>
---	--





DATE: / /

PAGE NO.:

$$13+7 = 20$$

$$15+7 = 22$$

$$17+7 = 24$$

$$20-5 = 15$$

$$22-5 = 17$$

$$24-5 = 19$$

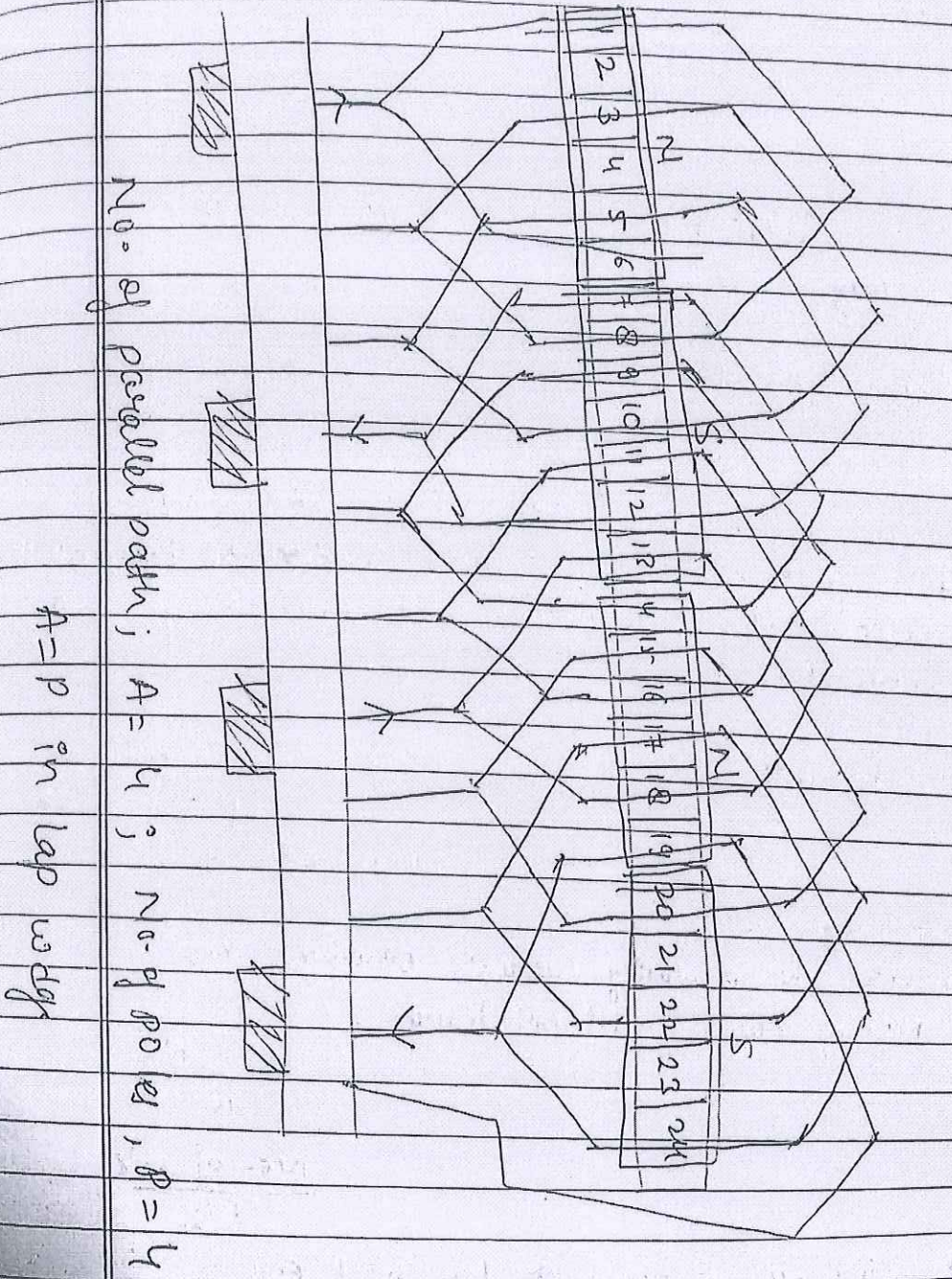



BHARTIYA SKILL DEVELOPMENT UNIVERSITY

Registration No.:

School of Electrical Skills
Session: 2020-21 (Summer Semester)
B. Voc. Program, 3rd Semester
End-Sem. Examination

Course Code: ELE1302

Time: 2 Hours

Course Name: Electrical Machine-I

Max. Marks: 50

Instruction: Answer all questions from section A, each question carries one mark. Answer all questions from section B, each question carries four marks. Answer all questions from section C, each question carries six marks. Scientific calculator is allowed.

Section – A

10X01 = 10 Marks

1. A D.C. motor can be looked upon as a D.C. generator with flow of current:
(a) Reduced (b) Reversed (c) Increases (d) Modified
2. As the load is increased, the speed of the DC shunt motor:
(a) Increases (b) Remains constant (c) Increases slightly (d) Reduces slightly
3. If supply frequency of transformer increases, the output voltage of the transformer:
(a) Increases (c) Decreases
(b) Remains the same (d) Can both increase and decrease
4. Power Transformer are designed to have maximum efficiency at:
(a) No load (b) 75% load (c) 50% load (d) Full load
5. The current drawn by a 120 V D.C. motor of armature resistance 0.5 ohms and back emf of 110 V is _____ amperes.
(a) 20 (b) 60 (c) 240 (d) 6
6. Carbon Brushes are placed on:
(a) MNA axis (c) GNA axis
(b) Can be placed anywhere (d) None of these
7. Value of Multiplicity factor for Simplex winding is:
(a) 4 (c) 1
(b) 2 (d) 3
8. Commutator is:
(a) Mechanical rectifier (c) Inverter
(b) Cycloconverter (d) Chopper
9. Transformer is a constant
(a) Power device (c) Frequency Device
(b) Revolution device (d) Both (a) and (c)
10. For maximum efficiency of transformer:
(a) Core loss must be high (c) Copper loss must be high
(b) Core loss = Copper loss (d) None of these

Section – B

04X04 = 16 Marks

1. Calculate the rating (kVA) of transformer having following parameters:
(a) No. of turns in primary winding – 400 (b) No. of turns in secondary winding – 800
(c) Primary voltage – 415 Volts (d) Secondary winding current – 80 Amperes
2. List the details available on the plate fixed on the transformer.

Signature
B



3. Explain the any 2 methods for starting of Single Phase Induction Motor.
4. Write short note on (a) PMDC motor and (b) BLDC motor.

Section – C

04X06 = 24 Marks

1. A DC shunt machine develops an e.m.f. of 250 V at 1500 r.p.m. Find its torque and mechanical power developed for an armature current of 50 A. State the simplifying assumptions.
2. Develop Simplex progressive lap winding 24 conductors & 4 poles.
3. A 4 pole, lap wound, d.c. generator has a useful flux of 0.07 Wb per pole. Calculate the generated e.m.f. when it is rotated at a speed of 900 r.p.m. with the help of prime mover. Armature consists of 440 number of conductors. Also calculate the generated e.m.f. if lap wound armature is replaced by wave wound armature.
4. Explain the protection of transformer by Buchholz relay.



(Ans. Key ELE 1302 Set – B)

BHARTIYA SKILL DEVELOPMENT UNIVERSITY

Registration No.:

School of Electrical Skills
Session: 2020-21 (Summer Semester)
B. Voc. Program, 3rd Semester
End-Sem. Examination

Course Code: ELE1302
Course Name: Electrical Machine-I

Time: 2 Hours
Max. Marks: 50

**Answer Key
Section-A**

1. B
2. D
3. B
4. D
5. A
6. A
7. C
8. A
9. D
10. B

Section-B

1. Turn ratio = $800/400 = 2$
Secondary Voltage = $2 * 415 = 830$ Volts
kVA rating = $830 * 80 / 1000 = 66.4$ kVA
2. Details on the Plate fixed on the Transformer
 1. Single/Three Phase transformer
 2. KVA rating
 3. HV winding Voltage
 4. HV winding Current
 5. LV winding Voltage
 6. LV winding Current
 7. Losses in watts– at Full load, at Half load
 8. Vector Group (how the primary and secondary windings are connected and also about whether Neutral is earthed or not earthed)
 9. % Impedance or Impedance Voltage (It is the supply voltage as a percentage of rated voltage, that is required to circulate the rated current through the transformer, keeping the other side of the transformer winding short circuited)
 10. Serial No of Transformer
 11. Date/Year of manufacturing
 12. Volume and weight of the Cooling oil if used
 13. Permissible rise in temperature of the oil and windings under loaded conditions
 14. Customer (If made to order)
 15. Order No and date (if made to order)
 16. Total weight of the transformer
 17. The standards it complies for manufacturing (IS:1180 etc.)
3. **Methods to make single phase induction motor self-start:**
 - a) Split phase induction motor:

A split phase induction motor consists of two main parts i.e., one is stator and other is rotor. On stator two windings are provided one is Main winding & other is Auxiliary winding. Both windings are 90° electrical apart & are connected in parallel across the single phase AC supply with centrifugal switch. Auxiliary winding has a high resistance and low reactance so there will be 90° phase shift occurs and a rotating magnetic field is developed and torque is generated to rotate the rotor. Once rotor starts rotating the centrifugal switch gets open and rotor continuously rotates.

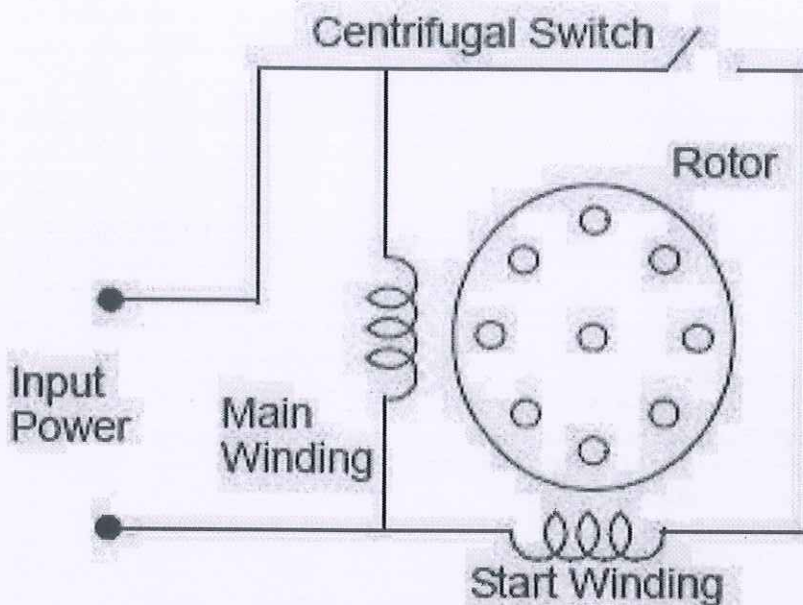

Fig. Circuit diagram of split phase induction motor

b) Capacitor start motor:

In this motor, capacitor is connected in series with the start winding with centrifugal switch. Here, due to capacitor current leads 90° from voltage and creates phase shift. Hence the rotor feels force and starts rotating. This motor has high starting torque, about 1.5 times the full load torque.

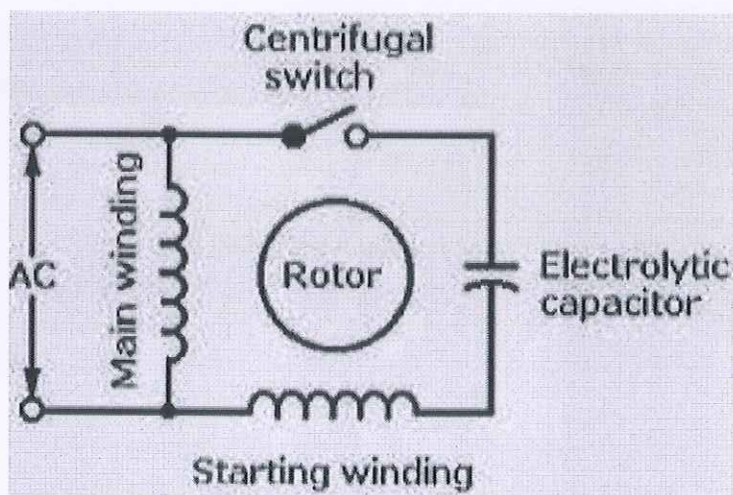
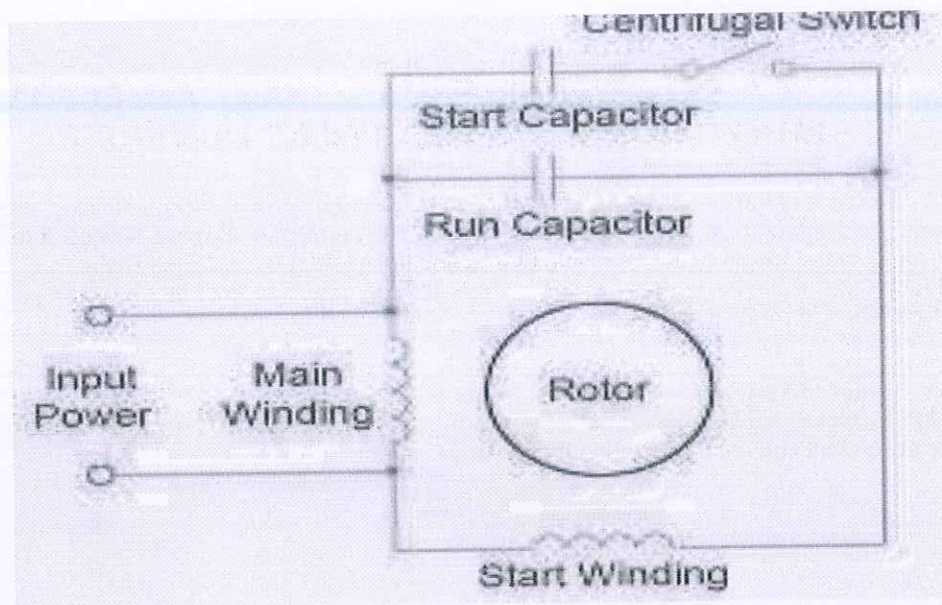

Fig. Circuit diagram of capacitor start induction motor

c) Capacitor start & Capacitor run motor:

In this motor, two capacitors are connected in parallel, one with centrifugal switch and other with starting winding. Through this method power factor of induction motor also gets improved.



02 Set – B)

ry loads.

Fig. Circuit diagram of capacitor start & capacitor run induction motor

4. A) PMDC motor:

A **Permanent Magnet DC motor (PMDC motor)** is a type of DC motor that uses a permanent magnet to create the magnetic field required for the operation of a DC motor.

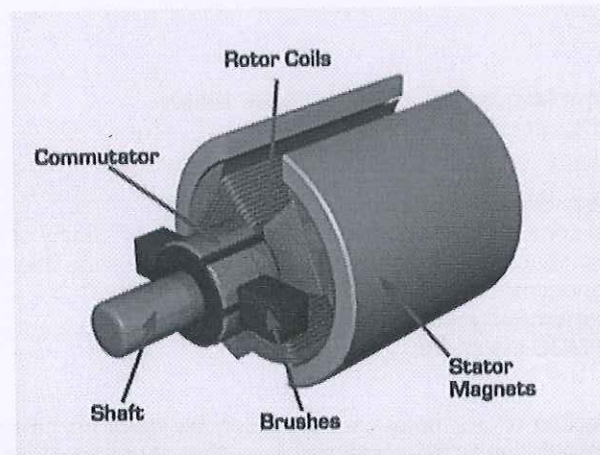

- The motor that drives these toys is nothing but a **permanent magnet DC motor** or **PMDC motor**. These types of motors are simple in construction.
- They are commonly used as a starter motor in automobiles, windshield wipers, washers, blowers used in heaters and air conditioners, to raise and lower windows – and they are extensively used in toys.
- As the magnetic field strength of a permanent magnet is fixed it cannot be controlled externally, field control of this type of DC motor cannot be possible.
- Thus permanent magnet DC motor is used where there is no need to control the speed of the motor (which is usually done by controlling the magnetic field). Small fractional and sub-fractional KW motors are often constructed using a permanent magnet.

Working Principle of Permanent Magnet DC Motor or PMDC Motor

As we said earlier the working principle of PMDC motor is just similar to the general working principle of DC motor. That is when a carrying conductor comes inside a magnetic field, a mechanical force will be experienced by the conductor and the direction of this force is governed by Fleming's left hand rule. As in a permanent magnet DC motor, the armature is placed inside the magnetic field of a permanent magnet; the armature rotates in the direction of the generated force.



Here each conductor of the armature experiences the mechanical force $F = B \cdot I \cdot L$ Newton where, B is the magnetic field strength in Tesla (weber / m²), I is the current in Ampere flowing through that conductor and L is the length of the conductor in meter comes under the magnetic field. Each conductor of the armature experiences a force and the compilation of those forces produces a torque, which tends to rotate the armature.

Equivalent Circuit of Permanent Magnet DC Motor or PMDC Motor

As in the PMDC motor, the field is produced by a permanent magnet, there is no need for drawing field coils in the equivalent circuit of a permanent magnet DC motor.

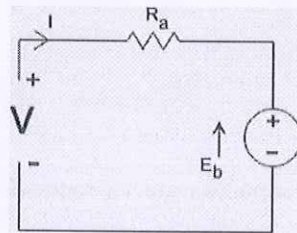

The supply voltage to the armature will have armature resistance drop and the rest of the supply voltage is countered by the back emf of the motor. Hence the voltage equation of the motor is given by,

$$V = IR + E_b$$

Advantages of Permanent Magnet DC Motor or PMDC Motor

The advantages of a PMDC motor are:

1. No need of field excitation arrangement.
2. No input power is consumed for excitation which improves efficiency of DC motor.
3. No field coil hence space for field coil is saved which reduces the overall size of the motor.
4. Cheaper and economical for fractional kW rated applications.

Disadvantages of Permanent Magnet DC Motor or PMDC Motor

The disadvantages of a PMDC motor are:

1. The armature reaction of DC motor cannot be compensated hence the magnetic strength of the field may get weak due to the demagnetizing effect of the armature reaction.
2. There is a chance of getting the poles permanently demagnetized (partial) due to excessive armature current during the starting, reversal, and overloading conditions of the motor.
3. The field in the air gap is fixed and limited – it cannot be controlled externally. This makes it difficult for this type of motor to achieve efficient speed control of DC motor in this type of motor is difficult.

Applications of Permanent Magnet DC Motor or PMDC Motor

PMDC motor is extensively used where small DC motors are required and also very effective control is not required, such as in automobiles starter, toys, wipers, washers, hot blowers, air conditioners, computer disc drives and in many more.

B) BLDC:

In Brush Less Direct Current motors, to eliminate the brushes of DC motors, **the armature windings are placed on the stator side and the magnets are placed on the rotor side**. As a result, BLDC motors have a different configuration from that of DC motors.

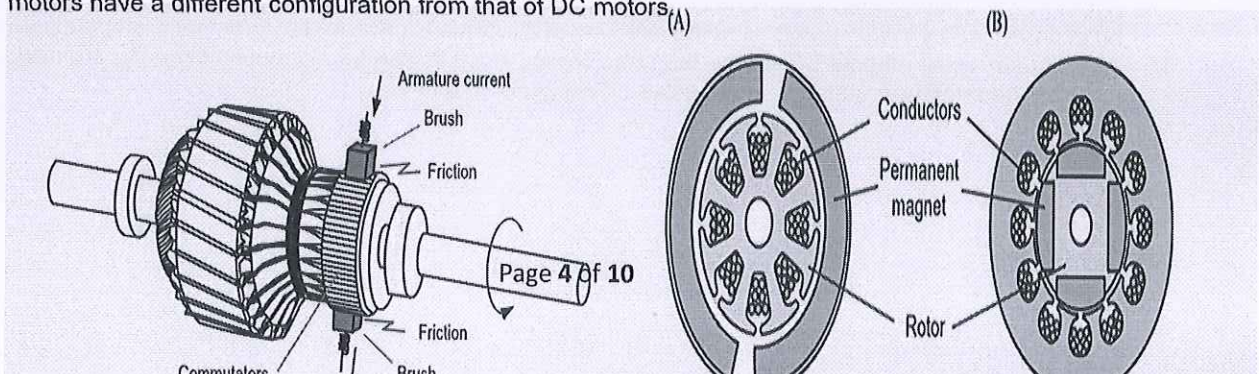
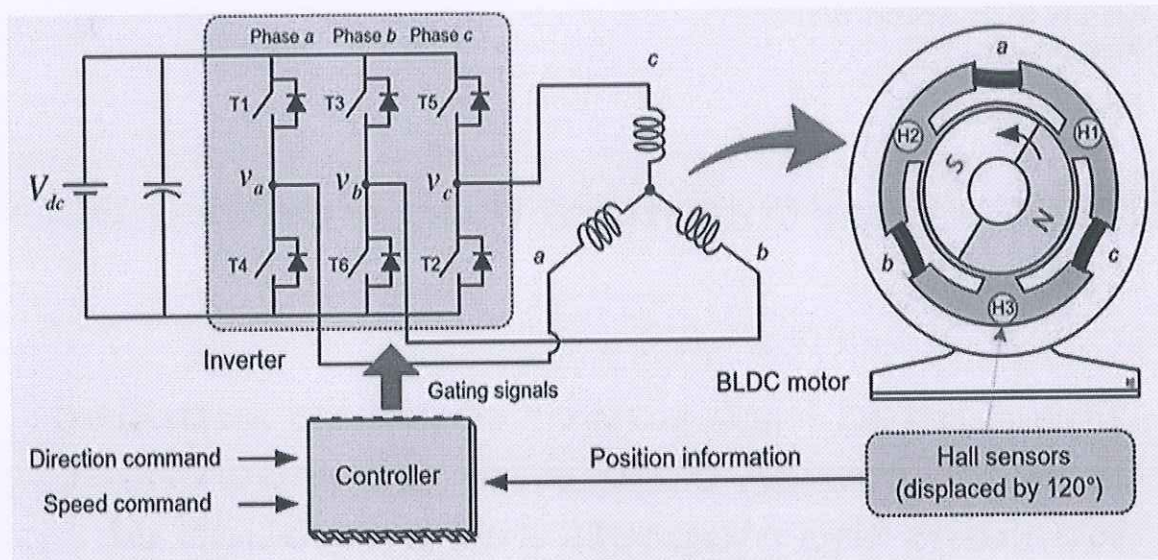

Fig.: Mechanical commutation devices of a DC motor.

Fig.: Configurations of (A) DC motor and (B) BLDC motor.

- The basic driving principle of the BLDC motor is to change the phase windings, which should be excited according to the position of permanent magnet on the rotor for producing a continuous torque.
- To implement this function, information on the rotor magnet position is indispensable.
- The position sensing is commonly achieved with Hall effect sensors.
- A two-pole three-phase Y-connected BLDC motor drive system is shown in figure. Three Hall effect sensors are displaced from each other by 120 electrical degrees on the stator to detect the magnetic field flux produced from the rotor magnets. Three output signals of Hall effect sensors enable us to recognize the rotor position divided into six different sections. Accordingly, a basic drive (often called six-step drive) to complete one electrical cycle consists of six different sections.



- The switching sequence for the six-step drive is illustrated in figure.
- In the BLDC motor drive, only two of the three-phase windings are excited, while the other winding is left unexcited.
- Rotor position feedback signals can be used to determine which two of the three-phase windings should be excited to produce the continuous torque at each instant.
- In the inverter for a BLDCM drive as shown in figure, switching devices of only two phases work at any given instant.
- Accordingly, each switching device has a 120 conduction interval.
- In the six-step drive, a changeover of an active switch is done to the switch of the other phase.
- Here, assume that each sensor outputs a digital high level for the north pole, whereas it outputs a low level for the south pole.
- From the sensor signals, the excited phase winding, i.e., an active phase winding, should be changed every 60 electrical degrees of rotation for producing a continuous torque



Advantages:

- As brushes are absent, the mechanical energy loss due to friction is less which enhanced *efficiency*, more reliable, high life expectancies, and maintenance free operation.
- BLDC motor can operate at high-speed under any condition.
- There is no sparking and much less noise during operation.
- Accelerate and decelerate easily because of low rotor inertia.
- High performance motor that provides large torque per unit volume over a vast speed range.
- Such motors cooled by conduction and no air flow are required for inside cooling.

Disadvantages:

- BLDC motor cost more than brushless DC motor.
- The limited high power could be supplied to BLDC motor, otherwise too much heat weakens the magnets and insulation of winding may get damaged.

Applications:

- **Single-speed** – Induction motors are suitable, but if the speed has to be maintained with the variation in load, then because of the flat speed-torque curve of BLDC motor, BLDC motors are a good fit.
- **Adjustable speed** – BLDC motors become a more suitable fit for such applications because variable speed induction motors will need an additional controller, thus adding to system cost. Brushed DC motors will also be a more expensive solution because of regular maintenance.
- **Position control** – BLDC motors use optical encoders, and complex controllers are required to monitor torque, speed, and position.
- **Low-noise applications** – Brushed DC motors are known for generating more EMI noise, so BLDC is a better fit, by using Field-Oriented Control (FOC) sinusoidal BLDC motor control.
- Hard Drives, CD Drivers, PC Cooling Fans, RC airplanes



Section-C

1. A given DC machine develops the same e.m.f. in its armature conductors whether running as a generator or as a motor. Only difference is that this armature e.m.f. is known as back e.m.f. when the machine is running as a motor.

Mechanical power developed in the arm = $E_b \cdot I_a = 250 \times 50 = 12,500 \text{ W}$
 $T_a = 9.55 E_b \cdot I_a / N = 9.55 \times 250 \times 50 / 1500 = 79.6 \text{ N-M.}$

2.

Pole pitch = $\frac{Z}{P} = \frac{24}{4} = 6 \text{ Z/pole}$

Avg-pitch ; $Y_A = \frac{Y_b + Y_f}{2} = \frac{Z}{P} \Rightarrow \text{Lap winding}$

$\frac{Y_b + Y_f}{2} = 6$
 $Y_b + Y_f = 12 \quad \text{--- (1)}$

$Y_b - Y_f = 2m \rightarrow \text{multiplicity factor}$
 $m = 1 \text{ for simplex}$
 $Y_b - Y_f = 2 \quad \text{--- (2)}$

$Y_b = \frac{14}{2} = 7 \quad \& \quad Y_f = 5$

1st coil side	$Y_b = 7$	1st last coil side	$Y_f = 5$
1 + 7 = 8		1st coil side	8 - 5 = 3
3 + 7 = 10		2nd last coil side	10 - 5 = 5
5 + 7 = 12			12 - 5 = 7
7 + 7 = 14			14 - 5 = 9
9 + 7 = 16			16 - 5 = 11
11 + 7 = 18			18 - 5 = 13



DATE: / /
PAGE NO.:

$$\begin{aligned} 13+7 &= 20 \\ 15+7 &= 22 \\ 17+7 &= 24 \end{aligned}$$

$$\begin{aligned} 20-5 &= 15 \\ 22-5 &= 17 \\ 24-5 &= 19 \end{aligned}$$

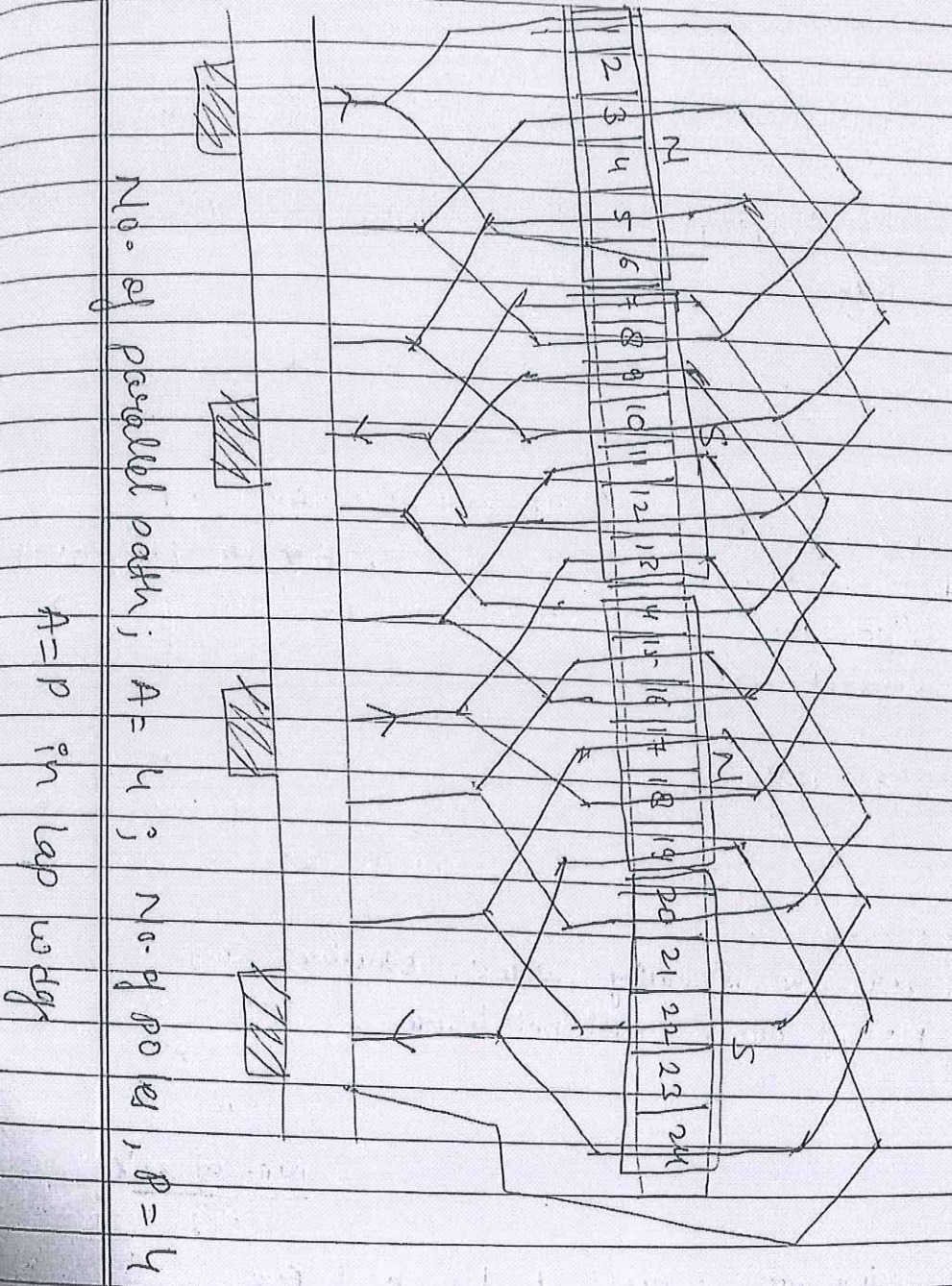



Given, $\phi = 0.07$ wb per pole
 Pole = 4
 $N = 900$ rpm
 $Z = 440$
 $E_g = ?$ in case of Lap wound $A = P = 4$

$$E_g = \frac{\phi Z N P}{60 A} = \frac{0.07 \times 440 \times 900 \times 4}{60 \times 4}$$

$$E_g = 462 \text{ volts}$$

→ In case of wave wound motor, $A = 2$

$$E_g'' = \frac{\phi Z N P}{60 A} = 462 \times 2 = 924 \text{ volts}$$

4. Working of Buchholz relay:

- The **Buchholz relay working principle** is very simple. **Buchholz relay function** is based on very simple mechanical phenomenon. It is mechanically actuated. Whenever there will be a minor internal fault in the transformer such as an insulation fault between turns, breakdown of core of the transformer, core heating, the insulating transformer oil will be decomposed in different hydrocarbon gases, CO₂ and CO. The gases produced due to the decomposition of transformer insulating oil will accumulate in the upper part the Buchholz container which causes fall of oil level in it.
- Fall of oil level means lowering the position of the float and thereby tilting the mercury switch. The contacts of this mercury switch are closed and an alarm circuit energized. Sometimes due to oil leakage on the main tank air bubbles may be accumulated in the upper part of the Buchholz container which may also cause a fall of oil level in it and the alarm circuit will be energized. By collecting the accumulated gases from the gas release pockets on the top of the relay and by analysing them one can predict the type of fault in the transformer.
- More severe types of faults, such as short circuit between phases or to earth and faults in the tap changing equipment, are accompanied by a surge of oil which strikes the baffle plate and causes the mercury switch of the lower element to close.

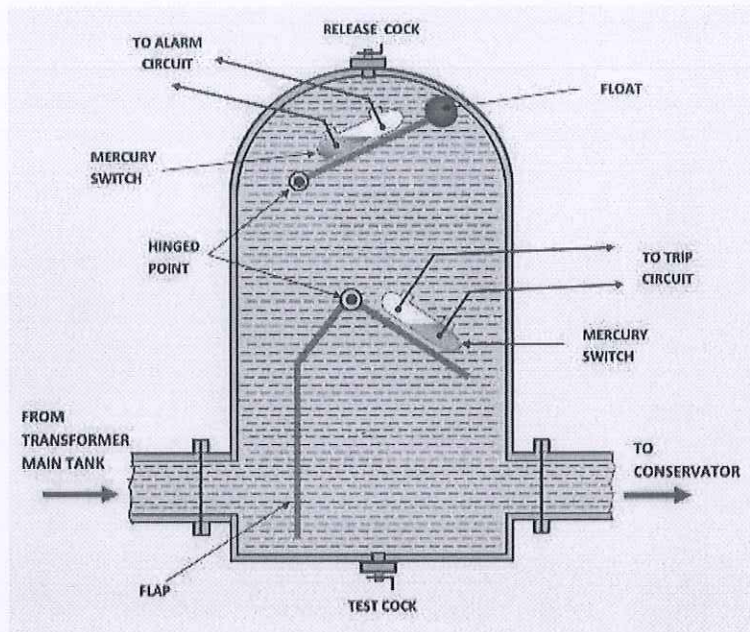

- This switch energized the trip circuit of the circuit breakers associated with the transformer and immediately isolate the faulty transformer from the rest of the electrical power system by inter tripping the circuit breakers associated with both LV and HV sides of the transformer. This is how **Buchholz relay functions**.



School of Electrical Skills
Session: 2020-21 (Summer Semester)
B. Voc. Program, 3rd Semester
End-Sem. Examination

Course Code: ELE1303

Time: 2 Hours

Course Name: Electrical Circuit & Drawing

Max. Marks: 50

Instruction: Answer all questions from section A, each question carries one mark. Answer all questions from section B, each question carries four marks. Answer all questions from section C, each question carries six marks. Scientific calculator is allowed.

Section – A**10X01 = 10 Marks**

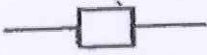
- ANSI number 27 represents:
(a) Overvoltage Relay
(b) Over Frequency relay
(c) Undervoltage Relay
(d) None of these
-  is the symbol representation of:
(a) Air Circuit Breaker
(b) Oil Circuit Breaker
(c) SF₆ Circuit Breaker
(d) None of these
- Unit of Capacitor is:
(a) Farad
(b) Nano Farad
(c) Micro Farad
(d) All of the these
- KVL works on the principle of:
(a) Charge conservation
(b) Power conservation
(c) Energy conservation
(d) None of these
- Transformer is a:
(a) Passive device
(b) Rotating device
(c) Active device
(d) None of these
- Is it advisable to connect different value of voltage sources in a parallel circuit without resistance in between them?
(a) Maybe
(b) Yes
(c) Absolutely Not
(d) None of these
- Active elements have:
(a) Positive slope coefficient
(b) Positive slope in 1st quadrant only
(c) Negative slope coefficient
(d) None of these
- Disadvantage of Maximum Power Transfer Theorem:
(a) Efficiency Gets reduced
(b) Efficiency Increased
(c) Power transferred is high
(d) None of these
- While calculation of the value of R_{th} all independent sources to be:
(a) Short Circuit
(b) Deactivated according to their internal resistance values
(c) Open Circuit
(d) None of these
- Norton's model is the _____ of the Thevenin's Model
(a) Source Transformation
(b) Voltage in parallel with Resistance
(c) Maximum Power transfer
(d) None of these

Section – B

04X04 = 16 Marks

1. Write short note on Single Line Diagram and its need in electrical system. Also draw any 10 symbols used in SLD.
2. Write the factors affecting the choice of wiring and also explain them.
3. Draw the Norton's equivalent circuit by using Thevenin equivalent circuit parameters and these are:
 (a) $V_{th} = 50$ volts (b) $R_{th} = 50$ ohms (c) $R_L = 10$ ohms.
 Also calculate the value of Current in load resistor using Current Division Rule.
4. Write short note on Characteristics of Electrical Elements with examples.

Section – C

04X06 = 24 Marks

1. Draw the planning flowchart for Single phase or Three phase supply for wiring installations in the building.
2. Calculate the value of current in 55-ohm resistor of heater using Thevenin's Theorem.

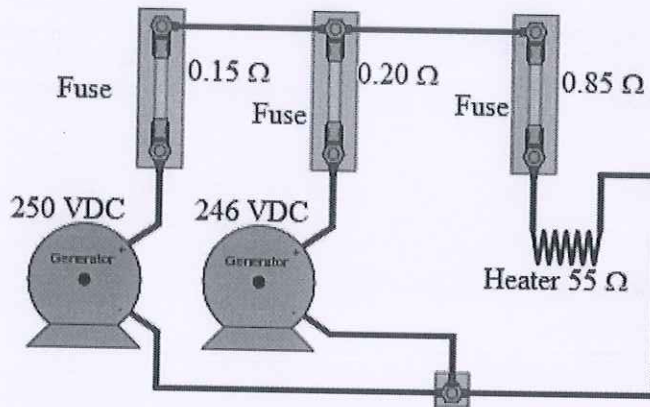

3. Calculate the value of R_L resistance using Maximum Power Transfer theorem and also calculate maximum power value in R_L .

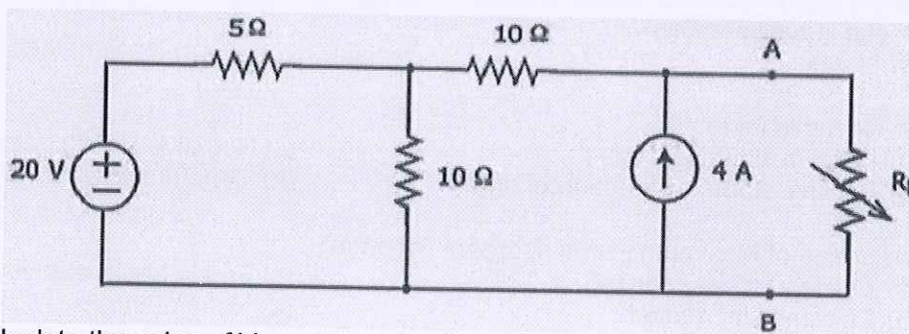

4. Calculate the value of V_{th} and R_{th} using thevenin theorem.

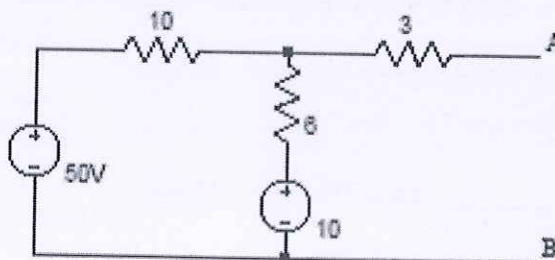



(Ans. Key ELE 1303 Set – A)
BHARTIYA SKILL DEVELOPMENT UNIVERSITY

School of Electrical Skills
Session: 2020-21 (Summer Semester)
B. Voc. Program, 3rd Semester
End-Sem. Examination

Course Code: ELE1303

Course Name: Electrical Circuit & Drawing

Time: 2 Hours

Max. Marks: 50

Answer Key
Section-A

1. C
2. B
3. D
4. C
5. A
6. C
7. C
8. A
9. B
10. A

Section - B

1. **Single Line Diagram (SLD): -**

- It is a simplified notation for representing a three phase power system.
- Electrical elements such as circuit breakers, transformers, capacitors, bus-bars, and conductors are shown by standardized schematic symbols.
- For analysis, the equivalent circuits of the components are shown in a reactance diagram or an impedance diagram.
- In many power system studies synchronous generator resistance, resistance of transformer winding, resistance of transmission line, line charging, are neglected.
- The impedance diagram than become reactance diagram.

Need of SLD: -

- The single line diagram has its largest applications in power flow studies.
- The single line diagram is also useful for understanding the design of power grid.
- For any electrical system before installation we need to prepare its single line diagram for better understanding of process.
- A properly drawn SLD shows a correct power distribution path from the incoming power source to each downstream load including the ratings and sizes of each piece of electrical equipment, their circuit conductors, and their protective devices.
- Making the electrical system easily understandable for any technical person inside/outside of the factory.

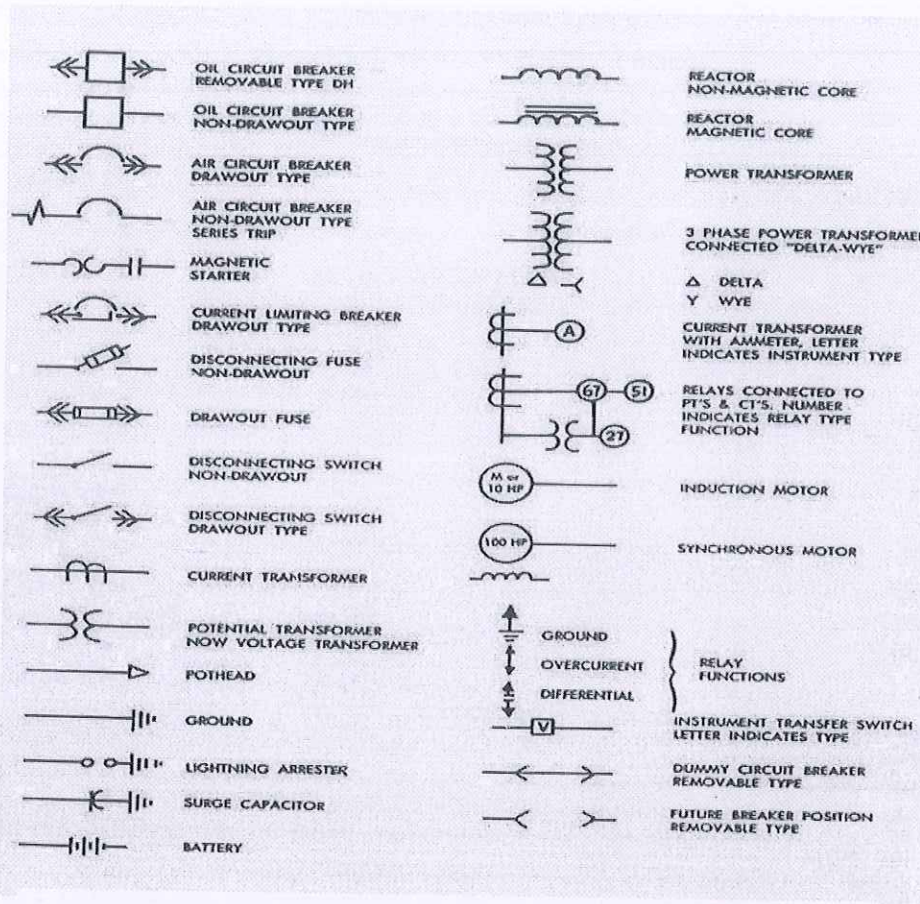

Motor or generator



Two-winding transformer



Transmission line



Liquid (oil) circuit breaker

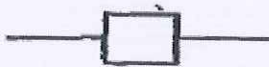

Air circuit breaker



Delta connection



Wye connection, ungrounded



Wye connection, grounded





2.

Factors Affecting the Choice of Wiring

- Durability : Type of wiring selected should conform to standard specifications, so that it is durable i.e. without being affected by the weather conditions, fumes etc.
- Safety : The wiring must provide safety against leakage, shock and fire hazards for the operating personnel.
- Appearance : Electrical wiring should give an aesthetic appeal to the interiors.
- Cost: It should not be prohibitively expensive.
- Accessibility : The switches and plug points provided should be easily accessible. There must be provision for further extension of the wiring system, if necessary.
- Maintenance Cost : The maintenance cost should be a minimum.
- Mechanical safety : The wiring must be protected against any mechanical damage.

3.

Given $V_{th} = 50$ volts, $R_{th} = 50 \Omega$, $R_L = 10 \Omega$

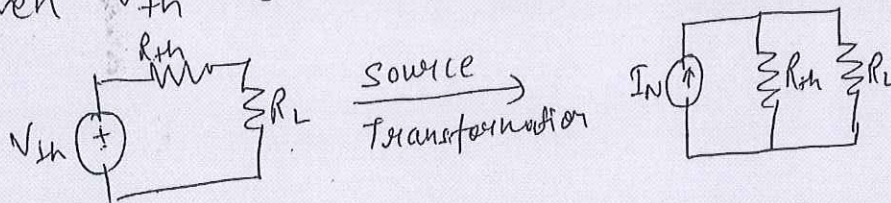

$$I_N = \frac{V_{th}}{R_{th}} = \frac{50}{50} = 1 \text{ A}$$

Use CDR,

$$I_L = I_N \times \frac{R_{th}}{R_L + R_{th}} = 1 \times \frac{50}{60} = 0.833 \text{ Amp}$$

4.

★ Characteristics of Electrical Elements :-

(I) On the basis of I-V characteristics, the elements are categorized in the following category :-

- (a) Linear AND Non-linear
- (b) Bilateral AND Unilateral
- (c) Active AND Passive
- (d) Time variant AND Time Invariant elements

(a) Linear or Non-linear elements :-

If the I-V curve is a straight line & passing through origin then it is linear otherwise it is non-linear element.

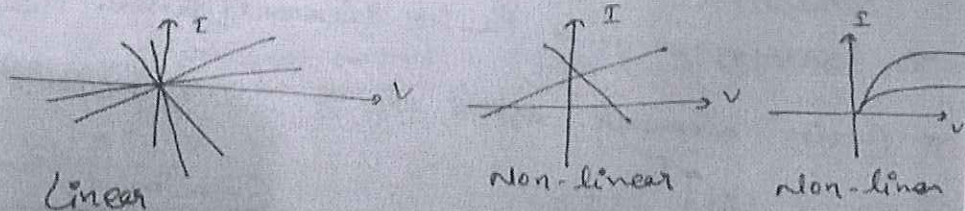

Linear elements Eg. R, L, C

Non-linear elements Eg. Diode, BJT, MOSFET, etc

(b) Unilateral AND Bilateral elements :-



{ I > 0 -> +ve
I < 0 -> -ve
quadrant

- Bilateral elements always offers same impedance in every region of I-V plane.
- Unilateral elements offer different impedances in I-V plane.

(c) Active and Passive elements :-

• If any element or n/w is capable of delivering a net amount of power or energy to the external world, then the element is known as Active otherwise Passive.

• The active or passive nature depends upon ckt conditions.

* Transformer is a Passive element / device.

* Active elements offers always -ve impedance. Eg.

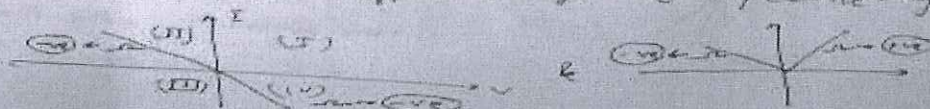

* Passive elements offers always +ve impedance.

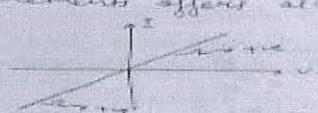

NOTE → If there is any -ve slope in I-V curve then the element is in active nature otherwise Passive.

⊙ Time variant or Time Invariant element :-

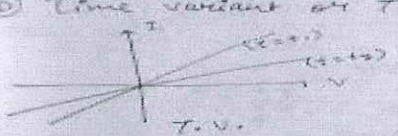

(i) T.V.

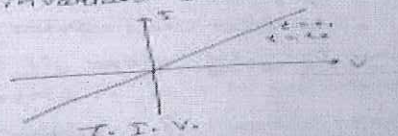

(ii) T.I.V.

Some Ex

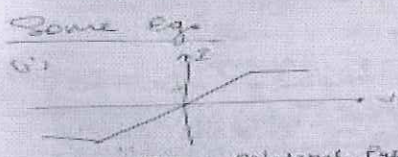

(iii) (Non-linear, Bilateral, Passive)

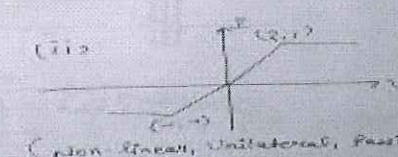

(iv) (Non-linear, Unilateral, Passive)

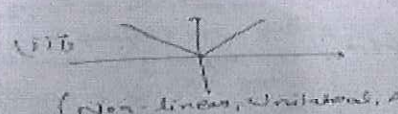

(v) (Non-linear, Unilateral, Active)

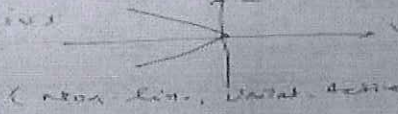

(vi) (Non-linear, Bilateral, Active)

Section - C



1.

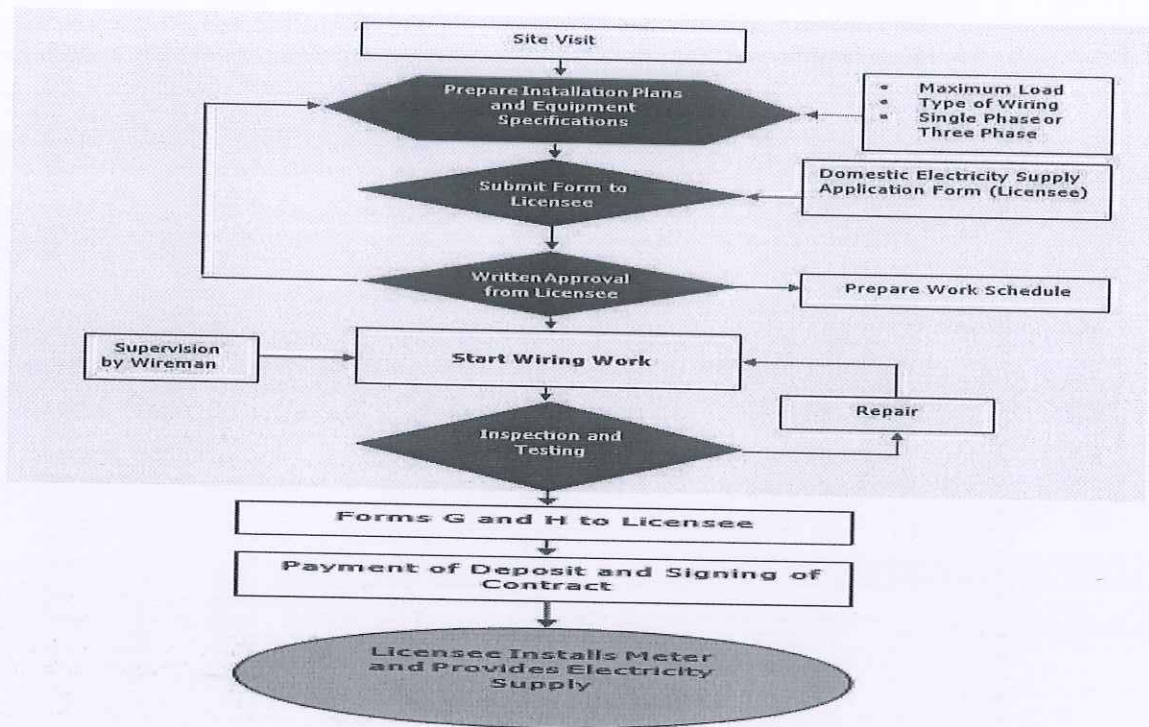

2.

Generator as a voltage source & all fwe & heater can be shown by Resistance

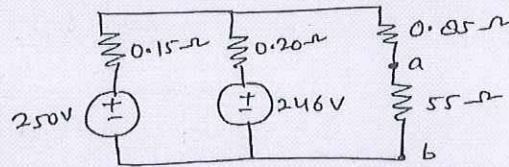

Step 1 Remove 55Ω resistor & calculate V_{th}

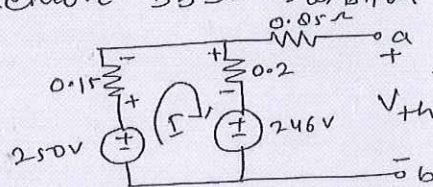

Apply KVL in loop.

$$250 - 0.35I - 246 = 0$$

$$I = \frac{4}{0.35} = 11.42 \text{ Amp.}$$

Now apply KVL in outer ~~loop~~ bigger loop

$$246 - 0.2 \times I + 42$$

$$250 - 0.15 \times 11.42 - V_{th} = 0$$

$$V_{th} = 250 - 1.713 = 248.28 \text{ volt}$$

Step 2 Deactivate all sources & calculate R_{th}

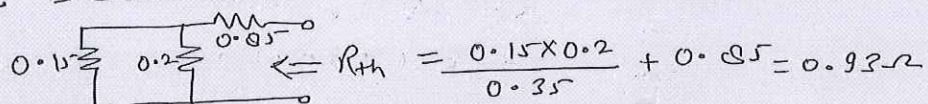

Step 3 Draw Thevenin equivalent circuit,

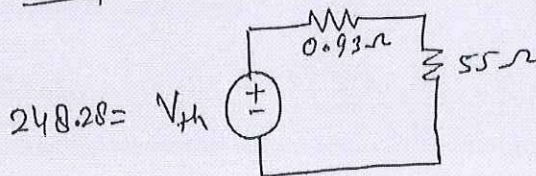

$$I = \frac{V_{th}}{R_{th} + R_L}$$

$$I = 4.43 \text{ Amp. } \checkmark$$

3.

Step 1 Calculate R_{th} ; deactivate all sources through their internal resistance:-

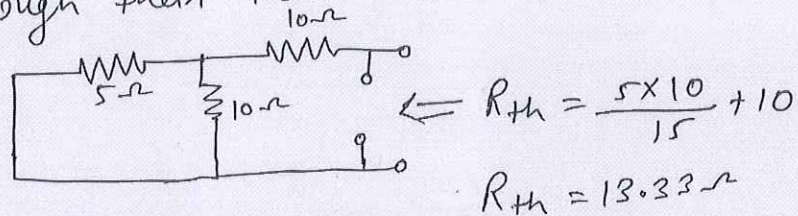

Step 2 For maximum power transfer,
 $R_{th} = R_L = 13.33 \Omega$

Step 3 Calculate V_{th} using Nodal Analysis.

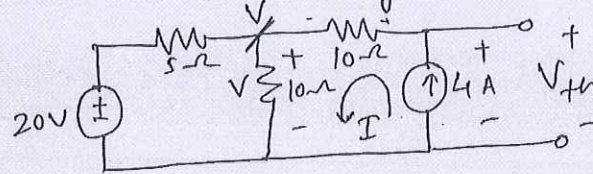

$$\frac{V-20}{5} + \frac{V}{10} = 4 \Rightarrow 2V-40+V=40$$

$$\Rightarrow 3V=80 \Rightarrow V=26.66 \text{ volts}$$

Apply KVL in loop (I)

$$V_{th} - 10 \times 4 - V = 0$$

$$\Rightarrow V_{th} = 40 + 26.66 = 66.66 \text{ volts}$$

Step 4 Draw Thevenin equivalent circuit diagram.

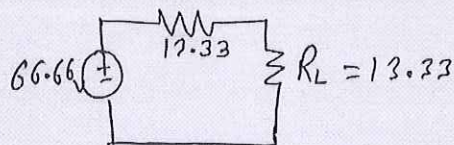

$$P = \frac{V_{th}^2}{4 R_{th}} = \frac{66.66 \times 66.66}{4 \times 13.33} = 83.33 \text{ watts.}$$



4.

Step 1 Calculate V_{th} across AB terminals.

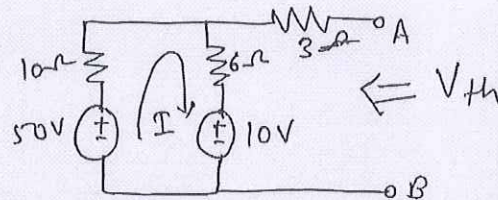

Apply KVL in loop,

$$50 - (10 + 6)I - 10 = 0$$

$$\Rightarrow I = \frac{40}{16} = 2.5 \text{ Amp.}$$

Apply KVL in bigger loop,

$$50 - 10 \times I - V_{th} = 0$$

$$V_{th} = 50 - 25 = 25 \text{ volt} \checkmark$$

Step 2 Deactivate all sources acc. to their internal resistance & calculate R_{th}

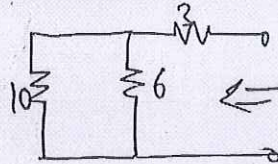

$$R_{th} = \frac{10 \times 6}{16} + 3 = 6.75 \Omega \checkmark$$



School of Electrical Skills
Session: 2020-21 (Summer Semester)
B. Voc. Program, 3rd Semester
End-Sem. Examination

Course Code: ELE1303

Time: 2 Hours

Course Name: Electrical Circuit & Drawing

Max. Marks: 50

Instruction: Answer all questions from section A, each question carries one mark. Answer all questions from section B, each question carries four marks. Answer all questions from section C, each question carries six marks. Scientific calculator is allowed.

Section – A

10X01 = 10 Marks

- ANSI number 59 represents:
(a) Overvoltage Relay
(b) Over Frequency relay
(c) Undervoltage Relay
(d) None of these
- This is the symbol of:

(a) Oil Circuit Breaker
(b) SF₆ Circuit Breaker
(c) Air circuit breaker
(d) None of these
- Unit of Inductor is:
(a) Nano Henry
(b) Micro Henry
(c) Henry
(d) All of these
- KCL works on the principle of:
(a) Charge conservation
(b) Power conservation
(c) Energy conservation
(d) None of these
- Battery is a:
(a) Passive device
(b) Detecting device
(c) Active device
(d) None of these
- Number of Mesh Equations in an electric network can be given by:
(a) = no. of meshes
(b) = branches – 1
(c) Both (a) & (b)
(d) None of these
- Efficiency in case of Maximum Power Transfer is:
(a) 75%
(b) 100%
(c) 50%
(d) None of these
- Full form of PVC:
(a) Polovinyl Chloride
(b) Photovoltaic Control
(c) Polyvinyl Chloride
(d) None of these
- Number of Nodal Equations can be given by:
(a) = branch – node – 1
(b) = no. of nodes – 1
(c) Both (a) & (b)
(d) None of these
- Colour of wire used for Earthing purpose is of:
(a) Green Colour
(b) Yellow – Green Colour
(c) Both (a) and (b)
(d) None of these

Signature
B

Section – B

04X04 = 16 Marks

1. Draw the planning flowchart for Single phase or Three phase supply for wiring installations in the building.
2. Write the points to be considered while selecting any system of wiring.
3. Write short note on Characteristics of Electrical Elements with examples.
4. State Ohm's KVL, KCL and Faradays' law of electromagnetic induction.

Section – C

04X06 = 24 Marks

1. Draw 33/11 KV substation drawing and also write the basic details of the different electrical equipment used.
2. Calculate the value of R3 resistance for Maximum Power Transfer and also calculate the maximum power in R3 resistance.

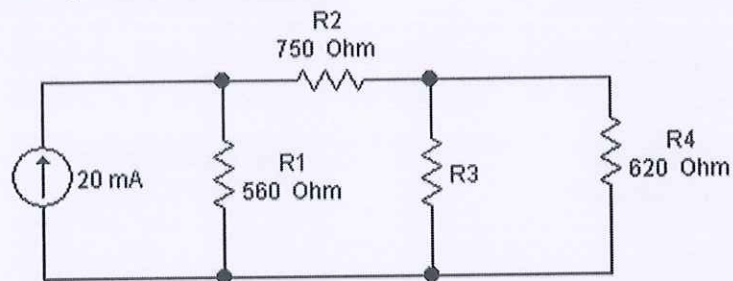

3. Calculate the value of current in 55-ohm resistance using Thevenin Theorem.

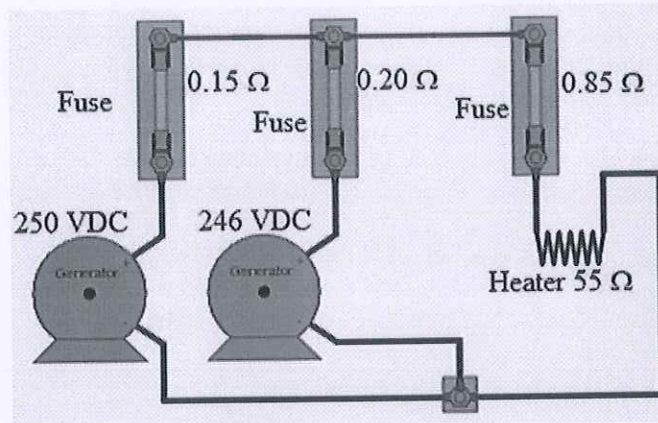

4. Find the voltage across 2-ohm resistor using Superposition Theorem.

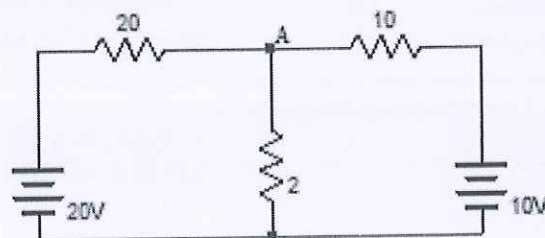



(Ans. Key ELE 1303 Set – B)
BHARTIYA SKILL DEVELOPMENT UNIVERSITY

Registration No.:

School of Electrical Skills
Session: 2020-21 (Summer Semester)
B. Voc. Program, 3rd Semester
End-Sem. Examination

Course Code: ELE1303

Course Name: Electrical Circuit & Drawing

Time: 2 Hours

Max. Marks: 50

**Answer Key
Section-A**

1. A
2. C
3. D
4. A
5. C
6. A
7. C
8. C
9. B
10. C

Section-B

1.

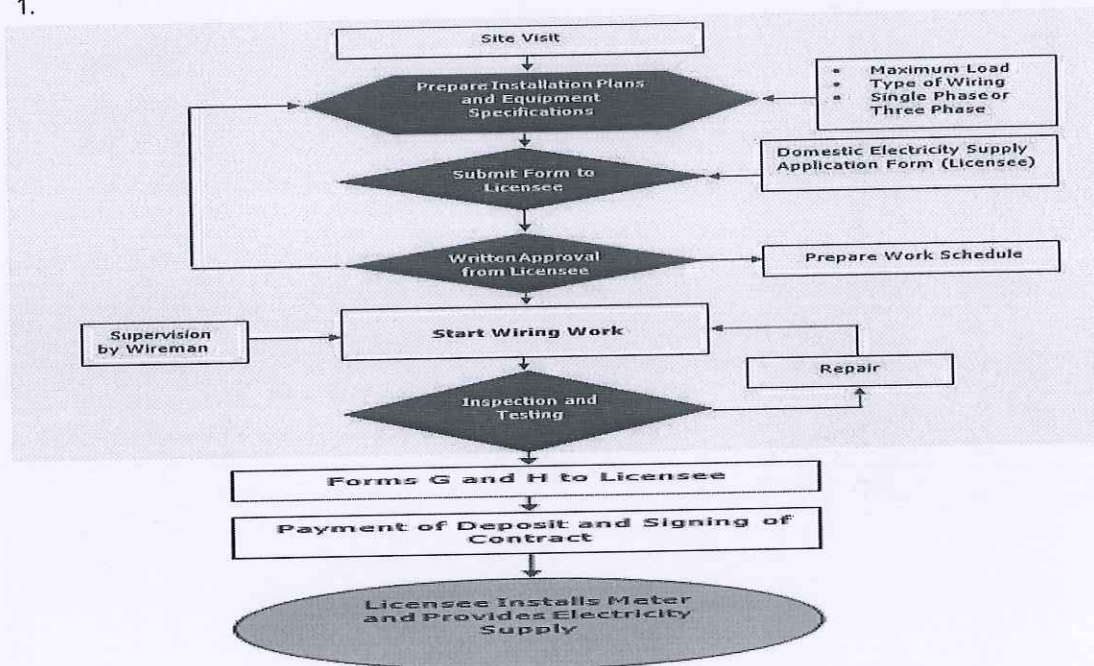

2.

Points to be Considered While Selecting Any System of Wiring

- Life of installation
- Future extension or alterations
- Construction of building
- Fire hazards or other special conditions
- Corrosive fumes (Gases which are responsible for corrosion)
- Dampness (Unwanted Moisture)
- Type of wire and material used
- Nature of load (lighting or power)
- Safety of the system
- Cost of wiring system

3.

★ Characteristics of Electrical Elements :-

(I) On the basis of I-V characteristics, the elements are categorized in the following category :-

- Linear AND Non-linear
- Bilateral AND Unilateral
- Active AND Passive
- Time variant AND Time Invariant elements

(2) Linear or non-linear elements :-
If the I-V curve is a straight line & passing through origin then it is linear otherwise it is non-linear element.

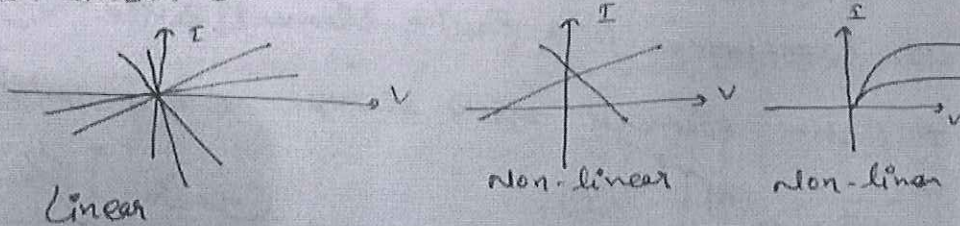

Linear elements Eg. R, L, C
 non-linear elements Eg. Diode, BJT, MOSFET, etc.

② Unilateral and Bilateral elements :-

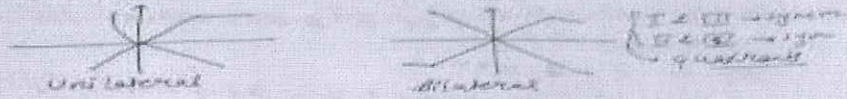

- Bilateral elements always offers same impedance in every region of I-V plane.
- Unilateral elements offer different impedances in I-V plane.

③ Active and Passive elements :-

- If any element or n/w is capable of delivering a net amount of power or energy to the external world, then the element is known as Active otherwise Passive.
- The active or passive nature depends upon ckt conditions.
- * Transformer is a Passive element/device.
- * Active elements offers always -ve impedance. Eg.

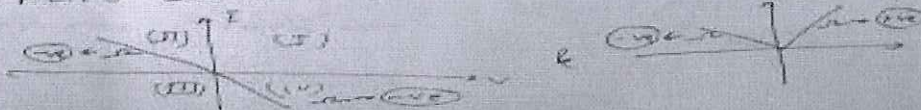

* Passive elements offers always +ve impedance.

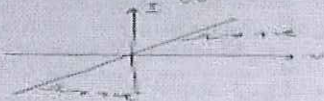

NOTE → If there is any -ve slope in I-V curve then the element is in Active nature otherwise Passive.

④ Time variant or Time Invariant element :-

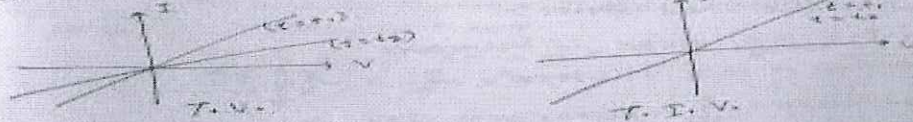

Some Egs

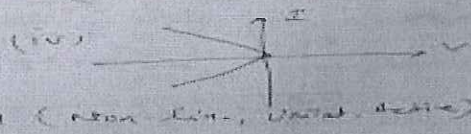
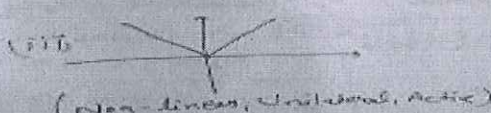
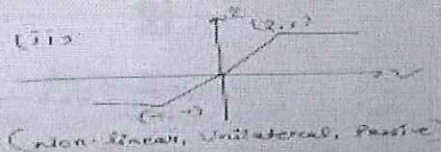
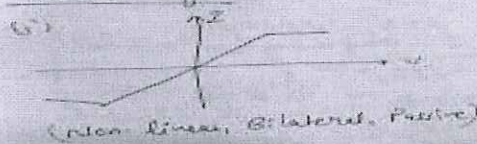

Wherever a voltage source is applied across a conductor, current will start flowing through it because of potential difference from higher potential to lower potential.

Ohm's Law states that the current flowing through a conductor is directly proportional to the potential difference (voltage) applied across its ends, provided that temperature and other physical conditions remain unchanged.

$$V \propto I$$

$$V = I \cdot R$$

Where R= proportionality constant, known as Resistance

- Ohm's law is not applicable for unilateral electrical elements like diodes and transistors as they allow the current to flow through in one direction only.
- For non- linear elements also, ohm's law is not applicable.

Ohm's Law triangle is shown below:

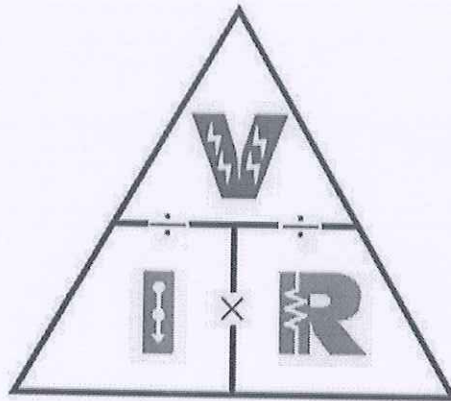

Kirchhoff's Law Statement

Kirchhoff's laws are one of the fundamental laws that find applications in electrical engineering for formulating the circuits. There are two laws that make up the Kirchhoff's law and they are:

- **Kirchhoff's Current Law (KCL):** KCL is also known as Kirchhoff's first law or junction rule. The principle of this law is to conserve the electric charge. The law states that the amount of current flowing into a node/junction is equal to the sum of currents flowing out of it. For performing the nodal analysis in Ohm's law, KCL is used.

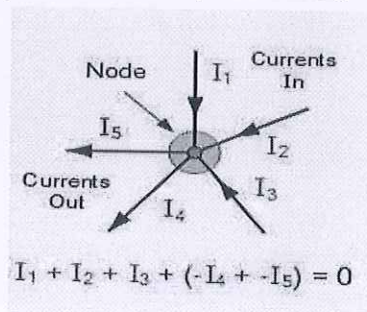

- **Kirchhoff's Voltage Law (KVL):** KVL is also known as Kirchhoff's second law or loop law. The principle of this law is to conserve energy. The law states that the sum of voltages in a closed-loop is zero. The total amount of energy gained is equal to the energy lost per unit charge.

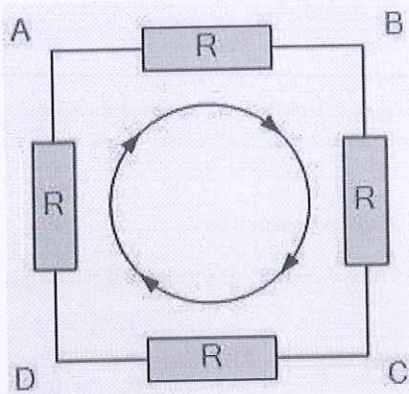

$$V_{AB} + V_{BC} + V_{CD} + V_{DA} = 0$$

Faradays' 1st law of EMI:

Whenever a conductor is placed in a varying magnetic field, an electromotive force is induced. If the conductor circuit is closed, a current is induced which is called induced current.

Faradays' 2nd law of EMI:

The induced emf in a coil is equal to the rate of change of flux linkage. The flux is the product of the number of turns in the coil and the flux associated with the coil. The formula of Faraday's law is given below:

$$\epsilon = -N \Delta \phi / \Delta t$$

Section-C

1.

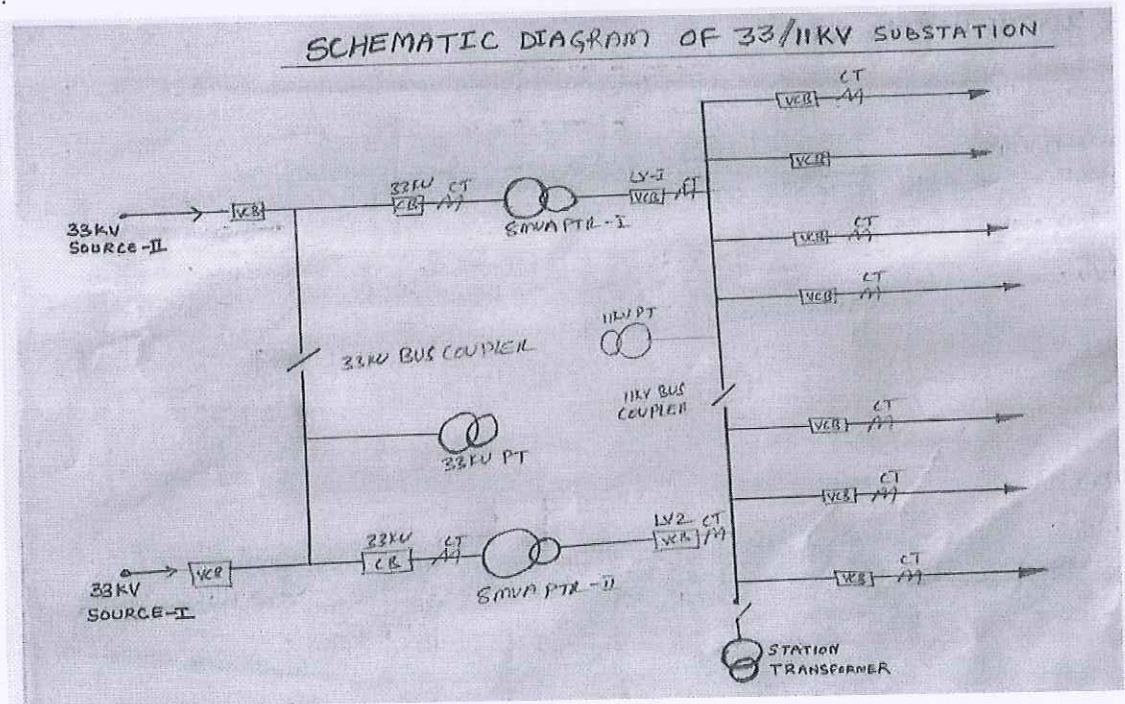

A typical package of single line diagram shall include: -

- Incoming lines showing voltage and size

- Incoming main fuses, cutouts, switches, and main/tie breakers
 - Power transformers (rating, winding connection)
 - Feeder breakers and fused switches rating.
 - Relays (function, use and type)
 - All main cable and wire runs with their associated isolating switches
 - All substations, including integral relays and main panels with total load of each feeder and each substation
 - A load schedule for each distribution panels and switch board.
 - Rating and numbers of bus bar.
 - All outgoing cables with cable size with rating and type of their associated isolating switches.
 - All connected load with their individual load capacity
- 2.

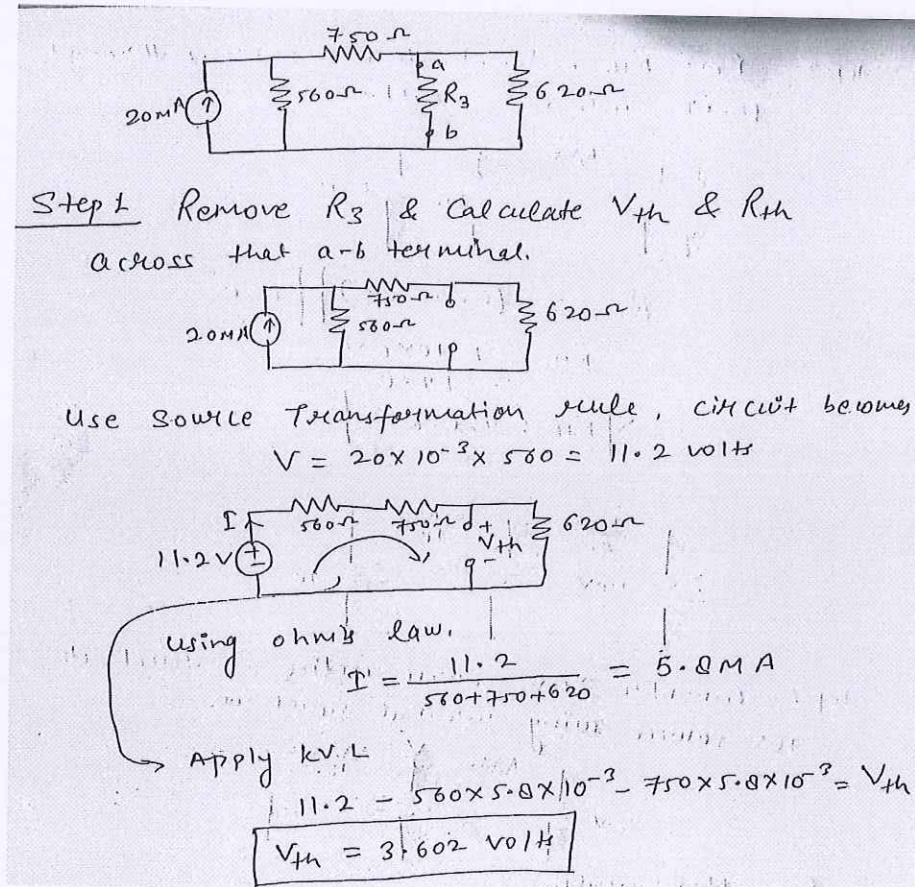

Step 1 Remove R_3 & Calculate V_{th} & R_{th} across that a-b terminal.

Use source transformation rule, circuit becomes

$$V = 20 \times 10^{-3} \times 560 = 11.2 \text{ volts}$$

using ohm's law,

$$I' = \frac{11.2}{560 + 750 + 620} = 5.8 \text{ mA}$$

Apply KVL

$$11.2 - 560 \times 5.8 \times 10^{-3} - 750 \times 5.8 \times 10^{-3} = V_{th}$$

$$V_{th} = 3.602 \text{ volts}$$

Step 2 For R_{th} , deactivate all sources through their internal resistance.

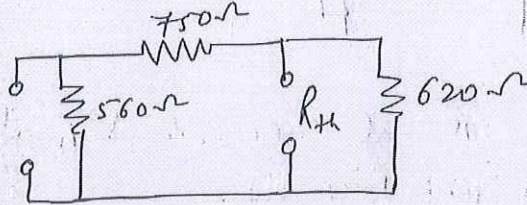

$$R_{th} = (560 + 750) \parallel 620$$

$$R_{th} = \frac{1310 \times 620}{1930}$$

$$\Rightarrow R_{th} = 420.8 \Omega$$

Step 3- For maximum power transfer, $R_L = R_{th} = R_3$

Maximum Power in load resistance $R_3 = V_{th}^2/4 * R_{th} = 3.62^2/4 * 420.8 = 7.78$ milli-watt

3.

Generator as a voltage source & all wire & heater can be shown by Resistance

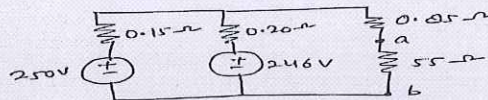

Step 1 Remove 55 ohm resistor & calculate V_{th}

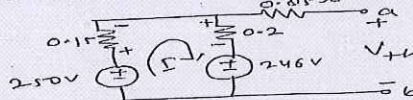

Apply KVL in loop.

$$250 - 0.35I - 246 = 0$$

$$I = \frac{4}{0.35} = 11.42 \text{ Amp.}$$

Now apply KVL in outer loop bigger loop

$$246 - 0.2 \times 11.42 - V_{th} = 0$$

$$V_{th} = 250 - 1.713 = 248.28 \text{ volt}$$

Step 2 Deactivate all sources & calculate R_{th}

$$R_{th} = \frac{0.15 \times 0.2}{0.35} + 0.05 = 0.93 \Omega$$

Step 3 Draw Thevenin equivalent circuit,

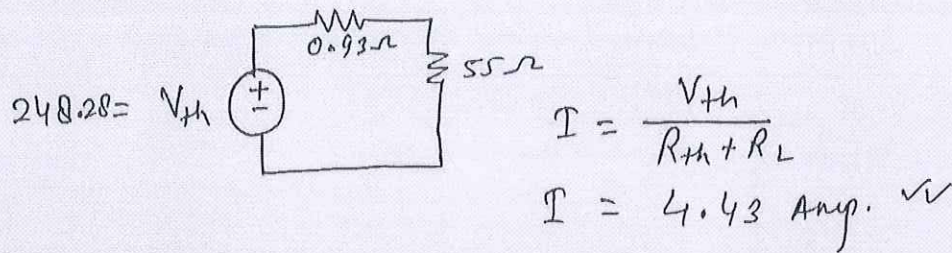

4.

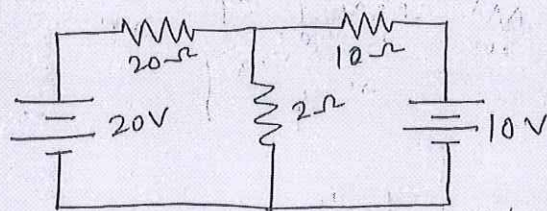

Step 1 Consider 20V source active & deactivate 10V source using internal resistance.

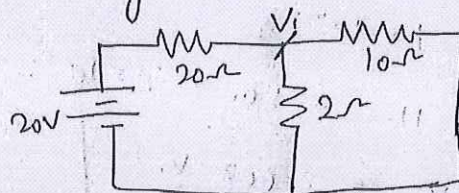

From Nodal analysis,

$$\frac{V_1 - 20}{20} + \frac{V_1}{2} + \frac{V_1}{10} = 0$$

$$\Rightarrow \frac{13V_1 - 20}{20} = 0$$

$$\Rightarrow V_1 = \frac{20}{13} = 1.53 \text{ volts} \quad \text{--- (1)}$$

Step 2 Consider 10 volt source & deactivate 20 volt source

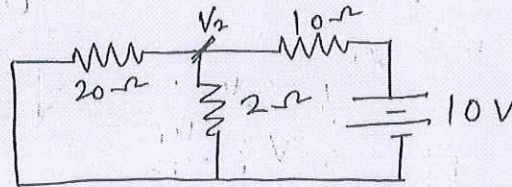

$$\Rightarrow \frac{V_2 - 10}{10} + \frac{V_2}{2} + \frac{V_2}{20} = 0$$

$$\Rightarrow \frac{2V_2 - 20 + 10V_2 + V_2}{20} = 0$$

$$\Rightarrow 13V_2 = 20$$

$$V_2 = 1.52 \text{ volts} \quad \text{--- (2)}$$

Step 3 Voltage across 2Ω resistor
 $= V_1 + V_2 = 1.53 + 1.53$
 $= 3.06 \text{ volts } \checkmark$



School of Electrical Skills
Session: 2020-21 (Summer Semester)
B. Voc. Program, 3rd Semester,
End-Sem. Examination

Course Code: ELE1304

Time: 2 Hours

Course Name: Electrical Measuring Instruments

Max. Marks: 50

Instruction: Answer all questions from section A, each question carries one mark. Answer all questions from section B, each question carries four marks. Answer all questions from section C, each question carries six marks. Scientific calculator is allowed.

Section – A

10X01 = 10 Marks

1. Change in output of sensor with change in input is:
(a) Threshold (b) Slew rate
(c) Sensitivity (d) None of the mentioned
2. The difference between the measured value and the true value is called
(a) mistake (b) error
(c) significant figure (d) fault
3. A _____ device prevents the oscillation of the moving system and enables the latter to reach its final position quickly.
(a) Deflecting (b) Controlling
(c) Damping (d) Any of these
4. The sensors are classified on the basis of:
(a) Functions (b) Performance
(c) Output (d) All of these
5. A piezo-electrical crystal generates voltage when subjected to _____ force.
(a) Electrical (b) Mechanical
(c) Gravity (d) All of these
6. Hall Effect sensors are used in:
(a) Flow meter (b) Fuel level indicator
(c) Both (a) and (b) (d) None of these
7. The more correct a sensor can measure, the more _____ it is:
(a) Accurate (b) Precise
(c) Scaled (d) Extent
8. Function of transducer is to convert
(a) Electrical signal into non electrical quantity
(b) Non electrical quantity into electrical signal
(c) Electrical signal into mechanical quantity
(d) All of these
9. For the measurement of pressure the instruments used can be
(a) Mechanical (b) Electro-mechanical
(c) Electronic (d) All of these
10. The electrical power to a Megger is provided by
(a) Battery (b) Permanent magnet D.C. generator
(c) AC. Generator (d) Any of these

Srinivas
A



BHARTIYA SKILL DEVELOPMENT UNIVERSITY

Section – B

04X04 = 16 Marks

1. Write various rules associated with writing S.I. Units.
2. Explain the term sensitivity and range with respect to instruments.
3. Explain the principal of ultrasonic transducers/sensors and mention its use.
4. What is the working principal of photo-electric type tachometer?

Section – C

04X06 = 24 Marks

1. What do you mean by term measuring instrument? Explain three types of secondary instruments.
2. In a series of successive measurements in an experiment, the readings of the period of oscillation of a simple pendulum were found to be 2.63s, 2.56 s, 2.42s, 2.71s and 2.80s. Calculate
 - (i) the mean value of the period of oscillation
 - (ii) the absolute error in each measurement
 - (iii) the percentage error.
3. Explain deflecting and controlling torque in indicating instruments.
4. Explain in detail any two sensor technology that are widely used for door safety.



Answer Key Set – A
Course Code: ELE1304, Course Name: Electrical Measuring Instruments
School of Electrical Skills, Session: 2020-21 (Summer Semester)
B. Voc. Program, III Semester, End-Sem. Examination

Section – A

1. (c) Sensitivity
2. (b) error
3. (c) Damping
4. (d) All of the above
5. (b) Mechanical
6. (c) Both (A) and (B)
7. (a) Accurate
8. (b) Non electrical quantity into electrical signal
9. (d) All of these
10. (c) AC. Generator

Section – B

1. (a) The units named after scientists are not written with a capital initial letter. For example: newton, henry, watt
(b) The symbols of the units named after scientist should be written by a capital letter. For example: N for newton, H for henry, W for watt
(c) Small letters are used as symbols for units not derived from a proper name. For example: m for meter, kg for kilogram
(d) No full stop or other punctuation marks should be used within or at the end of symbols. For example: 50 m and not as 50 m.
(e) The symbols of the units do not take plural form. For example: 10 kg not as 10 kgs

2. Sensitivity: The slope of the calibration curve $y=f(x)$ g. An ideal sensor will have a large and constant sensitivity.
It is the ratio of change in output to change in input. If Y be the output quantity in response to input X, then sensitivity S can be expressed as

$$S = \frac{dY}{dX} = \frac{\Delta Y}{\Delta X}$$

Range: It is the difference between the smallest and the largest outputs that a sensor can provide, or the difference between the smallest and largest inputs with which it can operate properly.

3. Ultrasonic devices are used in many fields of measurement, particularly for measuring fluid flow rates, liquid levels and translational displacements.

Ultrasound is a band of frequencies in the range above 20 kHz, that is, above the sonic range that humans can usually hear. Measurement devices that use ultrasound consist of one device that transmits an ultrasound wave and another device that receives the wave. Changes in the measured variable are determined either by measuring the change in time taken for the ultrasound wave to travel between the transmitter and receiver, or, alternatively, by measuring the change in phase or frequency of the transmitted wave.

4. It consists of a opaque disc mounted on the shaft whose speed is to be measured. The disc has a number of equivalent holes around the periphery. On the other side of the disc, there is a source of light while on one side there is a light sensor. On rotation of the disc, holes and opaque portions of the disc come alternately in between the disc and the holes in it. When a hole comes in between the two, the light passes through the hole and falls on the light sensor, with the result that an output is generated. But when the opaque disc portion comes in between, there is no light falling on the sensor and no output pulse is generated. Now, these pulses are counted using an electronic counter. The number of pulses generated by the device depends upon two factors, the number of holes in the disc and the speed of the shaft. Since, the number of holes in the disc are fixed, the speed of the shaft is the only input factor. The electronic counter may be therefore, calibrated in terms of speed (rpm). Following is an example of such a tachometer and its operation:

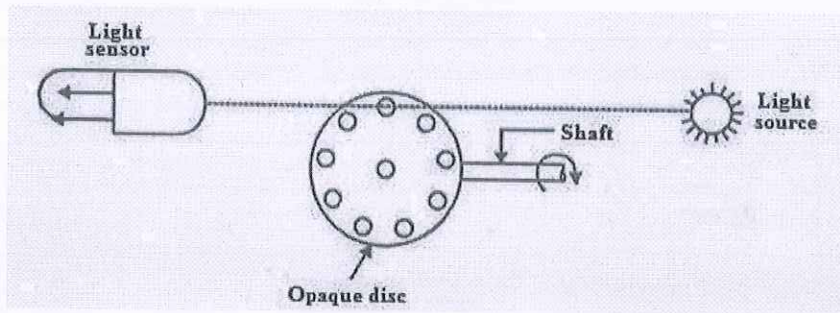

Section – C

- The device used for comparing the unknown quantity with the unit of measurement or standard quantity is called a Measuring Instrument. Secondary instruments are classified as-

Indicating Instrument– The instrument which indicates the magnitude of the measured quantity is known as the indicating instrument. The indicating instrument has the dial which moves on the graduated dial. The voltmeter, ammeter, power factor meter are the examples of the indicating instrument.

Integrating Instruments- The instrument which measures the total energy supplied at a particular interval of time is known as the integrating instrument. The total energy measured by the instrument is the product of the time and the measures electrical quantities. The energy meter, watt-hour meter and the energy meter are the examples of integrating instrument.

Recording Instrument– The instrument records the circuit condition at a particular interval of time is known as the recording instrument. The moving system of the recording instrument carries a pen which lightly touches on the paper sheet. The movement of the coil is traced on the paper sheet. The curve drawn on the paper shows the variation in the measurement of the electrical quantities.

- (i)

$$(i) \quad T_m = \frac{t_1 + t_2 + t_3 + t_4 + t_5}{5}$$

$$= \frac{2.63 + 2.56 + 2.42 + 2.71 + 2.80}{5}$$

$$T_m = \frac{13.12}{5} = 2.624s$$

$$T_m = 2.62s \quad (\text{Rounded off to 2}^{nd} \text{ decimal place})$$

- (ii)

$$\Delta T_1 = 2.62 - 2.63 = -0.01s$$

$$\Delta T_2 = 2.62 - 2.56 = +0.06s$$

$$\Delta T_3 = 2.62 - 2.42 = +0.20s$$

$$\Delta T_4 = 2.62 - 2.71 = -0.09s$$

$$\Delta T_5 = 2.62 - 2.80 = -0.18s$$

- (iii)

$$S_r = \frac{\Delta T_m}{T_m} = \frac{0.11}{2.62} = 0.0419$$

$$S_r = 0.04$$

$$\text{Percentage error in } T = 0.04 \times 100 = 4\%$$

- 3.

1. **Deflecting device.** whereby a mechanical force is produced by the electric current, voltage or power.

2. **Controlling device.** whereby the value of deflection is dependent upon the magnitude of the quantity being measured.

3. **Damping device.** to prevent oscillation of the moving system and enable the latter to reach its final position quickly.

1. Deflecting Device. A deflecting device produces a deflecting torque which is caused by anyone of the previously mentioned effects (i.e., thermal effect, chemical effect, electrostatic effect etc.) ; with the help of this deflecting torque the needle or the pointer moves from zero position to the final position. The arrangement of the deflecting device with each type of instrument will be discussed individually.

2. Controlling Devices. There are two types of controlling devices :

(i) Spring control

(ii) Gravity control.

(i) **Spring control.** Fig.1 shows a commonly used spring control arrangement. It utilises two spiral hair springs, 1 and 2, the inner ends of which are attached to the spindle S. The outer end of spring 2 is fixed while that of 1 is attached to a lever, the adjustment of which gives zero adjustments. The two springs 1 and 2 are wound in opposite directions so that when the moving system is deflected, one spring winds up while the other unwinds, and the controlling torque is due to the combined torsions of the springs.

Since the torsional torque of a spiral spring is proportional to the angle of twist, the controlling torque (T_c) is directly proportional to the angular deflection of the pointer (θ).

i.e., $T_c \propto \theta$.

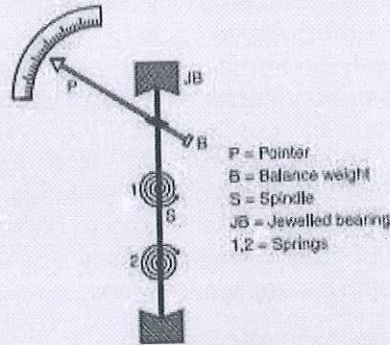

Fig. 1. Spring control.

4. Electric strike lock:

This facilitates remote access control by monitoring the intruder on video monitor & opening the door remotely. An electric strike is an access control device used for doors. It replaces the fixed strike faceplate often used with a latch bar (also known as a keeper). Like a fixed strike, it normally presents a ramped surface to the locking latch allowing the door to close and latch just like a fixed strike would. However, an electric strike's ramped surface can, upon command, pivot out of the way when lock on door is in the locked position and the door is opened, allowing a user to open the door without operating the mechanical lock or using a mechanical key. After the door is opened past the keeper, keeper returns to its standard position and relocks when power is removed or applied, depending upon strike's configuration.

The electric strike lock typically operates on +12V/950mA supply. Regular mechanical door lock/latch is utilised. It consists of latchable knob which latch automatically when door is pushed to close. It also consists of key to open the latched door from outside. There are two knobs on opposite side of key entry, one is small and other is big. The big knob is used to open door from inside and small knob is used to make the door latch or unlatch permanently. Electric door strike lock allows to open the door by pulling out when 12V supply is applied to its coil. Electric door strike uses regular mechanically operated using keys & turning knob to latch the door from inside. There is a mechanical lever inside strike socket, keep it down for electric latch to operate.

A) Electromagnetic door lock:

An electromagnetic lock, magnetic lock, or maglock is a locking device that consists of an electromagnet and an armature plate. There are two main types of electric locking devices. Locking devices can be either "fail safe" or "fail secure". A fail-secure locking device remains locked when power is lost. Fail-safe locking devices are unlocked when de-energized. Direct pull electromagnetic locks are inherently fail-safe. Typically the electromagnet portion of lock is attached to the door frame and a mating armature plate is attached to door. The two components are in contact when the door is closed. When the electromagnet is energized, a current passing through the electromagnet creates a magnetic flux that causes the armature plate to attract to electromagnet, creating a locking action. Because the mating area of the



Answer Key Set – A
Course Code: ELE1304, Course Name: Electrical Measuring Instruments
School of Electrical Skills, Session: 2020-21 (Summer Semester)
B. Voc. Program, III Semester, End-Sem. Examination

electromagnet and armature is relatively large, the force created by the magnetic flux is strong enough to keep the door locked even under stress.

Typical single door electromagnetic locks are offered in both 600 lbs (pounds) and 1200 lbs. dynamic holding force capacities. A "fail safe" magnetic lock requires power to remain locked and typically not suitable for high security applications because it is possible to disable the lock by disrupting the power supply. Despite this, by adding a magnetic bond sensor to the lock and by using a power supply that includes a battery backup capability, some specialized higher security applications can be implemented. Electromagnetic locks are well suited for use on emergency exit doors that have fire safety applications because they have no moving parts that are less likely to fail than other types of electric locks, like electric strikes. The strength of today's magnetic locks compares well with that of conventional door locks and they cost less than conventional light bulbs to operate. There are additional pieces of release hardware installed in a typical electromagnetic locking system. Since electromagnetic locks do not interact with levers or door knobs on a door, typically a separate release button that cuts lock power supply is mounted near the door. This button usually has a timer that, once the button is pressed, keeps the lock unlocked for either 15 or 30 seconds in accordance with NFPA (National Fire Prevention Association) fire codes. Additionally, a second release is required by fire code. Either a motion sensor or crash bar with internal switch is used to unlock to door on the egress side of the door automatically. The electromagnetic door lock holds the door in place when 12V supply is applied to its coil.

B) Glass break cum magnetic sensor:

A glass break detector is a sensor used in electronic burglar alarms that detects if a pane of glass is shattered or broken. These sensors are commonly used near glass doors or glass store-front windows to detect if an intruder broke the glass and entered. Glass break detectors usually use a microphone, which monitors any noise or vibrations coming from the glass. If the vibrations exceed a certain threshold (that is sometimes user selectable) they are analysed by detector circuitry. Simpler detectors simply use narrowband microphones tuned to frequencies typical of glass shattering, and react to sound above certain threshold, whereas more complex designs compare the sound analysis to one or more glass-break profiles using signal transforms similar to DCT (Discrete Cosine Transform) and FFT (Fast Fourier Transform) and react if both the amplitude threshold and statistically expressed similarity threshold are breached. Glass break sensor consists of 2 separate sensors inside but common NC (Normally Closed) output contact. Magnetic read switch combination as before when door opens, reed switch contact becomes open disconnecting further circuit.



School of Electrical Skills
Session: 2020-21 (Summer Semester)
B. Voc. Program, III Semester,
End-Sem. Examination

Course Code: ELE1304

Time: 2 Hours

Course Name: Electrical Measuring Instruments

Max. Marks: 50

Instruction: Answer all questions from section A, each question carries one mark. Answer all questions from section B, each question carries four marks. Answer all questions from section C, each question carries six marks. Scientific calculator is allowed.

Section – A

10X01 = 10 Marks

1. Which of the following is not an integrating instrument?
(a) Ampere-hour meter (b) Watt-hour meter
(c) Voltmeter (d) All of the above
2. Resistances can be measured with the help of:
(a) Watt-meters (b) Voltmeters
(c) Ammeters (d) Ohmmeters and resistance bridges
3. A moving iron type ammeter has few turns of thick wire so that:
(a) Resistance is less (b) Sensitivity is high
(c) Damping is effective (d) Scale is large
4. If damping torque is not provided in an instrument then
(a) Instrument will show full wave of quantity even under small values
(b) The pointer will move only when full rated load is provided
(c) The pointer will oscillate about its final deflected position and will never come to rest even under steady conditions
(d) The pointer will oscillate about its final deflected position for quite some time before coming to rest
5. Some substance generates the voltage when they are subjected to mechanical forces or stress along specific planes. Such substance is known as
(a) Piezoelectric (b) Thermo-electric
(c) Photo-electric (d) Radio-active
6. Hall Effect sensors are used in
(a) Flow meter (b) Fuel level indicator
(c) Both (A) and (B) (d) None of these
7. The more correct a sensor can measure, the more _____ it is:
(a) Accurate (b) Precise (c) Scaled (d) Extent
8. An ammeter is a:
(a) Secondary instrument (b) Absolute instrument
(c) Recording instrument (d) Integrating instrument
9. Which of the following is the cause of the speed error in the induction type energy meter?
(a) Incorrect Position of brake magnets
(b) Incorrect adjustment of the position of shading bands
(c) Slow but continuous rotation of an aluminum disc
(d) Temperature variations



10. The ability to give same output reading when same input value is applied repeatedly is known as:

- (a) Stability
- (b) Repeatability
- (c) Accuracy
- (d) Sensitivity

Section – B

04X04 = 16 Marks

1. Write various rules associated with writing S.I. Units.
2. What is meant by precision? Can we say an instrument of high precision is accurate?
3. Explain the difference between systematic and random errors. What are the typical sources of these two types of error?
4. What is the working principal of photo-electric type tachometer?

Section – C

04X06 = 24 Marks

1. Draw a schematic diagram showing construction details of an induction-type energy meter and label its different parts. Explain its working.
2. The refractive index (μ) of water is found to have the values 1.29, 1.33, 1.34, 1.35, 1.32, 1.36, 1.30 and 1.33. Calculate the mean value, absolute error, the relative error and the percentage error.
3. Explain deflecting and controlling torque in indicating instruments.
4. Explain in detail any two sensor technology that are widely used for door safety.

Section – A

1. (c) Voltmeter
2. (d) Ohmmeters and resistance bridges
3. (a) Resistance is less
4. (d) The pointer will oscillate about its final deflected position for quite some time before coming to rest
5. (a) Piezoelectric
6. (c) Both (A) and (B)
7. (a) Accurate
8. (a) Secondary instrument
9. (a) Incorrect Position of brake magnets
10. (b) Repeatability

Section – B

04X04 = 16 Marks

1. (a) The units named after scientists are not written with a capital initial letter. For example: newton, henry, watt
 (b) The symbols of the units named after scientist should be written by a capital letter. For example: N for newton, H for henry, W for watt
 (c) Small letters are used as symbols for units not derived from a proper name. For example: m for meter, kg for kilogram
 (d) No full stop or other punctuation marks should be used within or at the end of symbols. For example: 50 m and not as 50 m.
 (e) The symbols of the units do not take plural form. For example: 10 kg not as 10 kgs

2. Precision: is the capacity of a measuring instrument to give the same reading when repetitively measuring the same quantity under the same prescribed conditions. Precision implies agreement between successive readings, NOT closeness to the true value.

Precision is related to the variance of a set of measurements.

Precision is a necessary but not sufficient condition for accuracy.

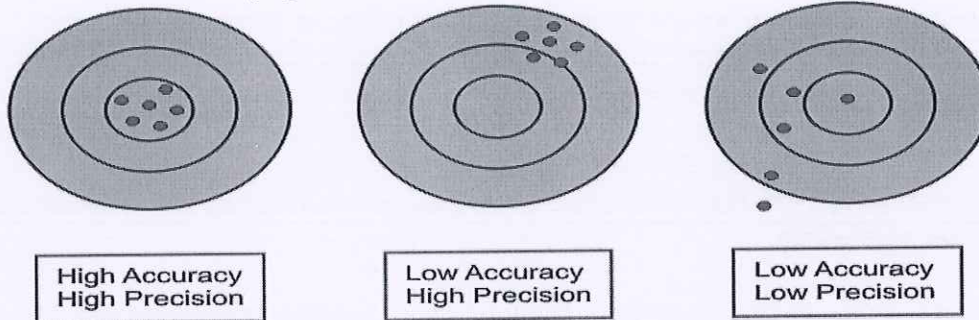

Precision describes an instrument's degree of freedom from random errors. If a large number of readings are taken of the same quantity by a high precision instrument, then the spread of readings will be very small. It is not necessary an instrument of high precision is accurate.

3. **Systematic Errors:** These are inherent errors of apparatus or method. These errors always give a constant deviation. On the basis of the sources of errors, systematic errors may be divided into following sub-categories :

Constructional Error

None of the apparatus can be constructed to satisfy all specifications completely. This is the reason of giving guarantee within a limit. Therefore, a manufacturers always mention the



Answer Key Set – B

Course Code: ELE1304, Course Name: Electrical Measuring Instruments

School of Electrical Skills, Session: 2020-21 (Summer Semester)

B. Voc. Program, III Semester, End-Sem. Examination

minimum possible errors in the construction of the instruments.

Errors in Reading or Observation

Following are some of the reasons of errors in results of the indicating instruments:

(a) Construction of the Scale: There is a possibility of error due to the division of the scale not being uniform and clear.

(b) Fitness and Straightness of the Pointer: If the pointer is not fine and straight, then it always gives the error in the reading.

(c) Parallax: Without a mirror under the pointer there may be parallax error in reading.

(d) Efficiency or Skill of the Observer: Error in the reading is largely dependent upon the skill of the observer by which reading is noted accurately.

Determination Error

It is due to the indefiniteness in final adjustment of measuring apparatus. For example, Maxwell Bridge method of measuring inductances, it is difficult to find the differences in sound of head phones for small change in resistance at the time of final adjustment. The error varies from person to person.

Error due to Other Factors Errors in Measurement

Temperature Variation- Variation in temperature not only changes the values of the parameters but

also brings changes in the reading of the instrument. For a consistent error, the temperature must be constant.

Effect of the Time on Instruments- There is a possibility of change in calibration error in the instrument with time. This may be called ageing of the instrument.

Effect of External Electrostatic and Magnetic Fields- These electrostatic and magnetic fields influence the readings of instruments. These effects can be minimized by proper shielding.

Mechanical Error- Friction between stationary and rotating parts and residual torsion in suspension wire cause errors in instruments. So, checking should be applied. Generally, these errors may be checked from time to time.

Random Errors

After corrections have been applied for all the parameters whose influences are known, there is left a residue of deviation. These are random error and their magnitudes are not constant. Persons performing the experiment have no control over the origin of these errors. These errors are due to so many reasons such as noise and fatigue in the working persons. These errors may be either positive or negative. To these errors the law of probability may be applied. Generally, these errors may be minimized by taking average of a large number of readings.

4. It consists of a opaque disc mounted on the shaft whose speed is to be measured. The disc has a number of equivalent holes around the periphery. On the other side of the disc, there is a source of light while on one side there is a light sensor. On rotation of the disc, holes and opaque portions of the disc come alternately in between the disc and the holes in it. When a hole comes in between the two, the light passes through the hole and falls on the light sensor, with the result that an output is generated. But when the opaque disc portion comes in between, there is no light falling on the sensor and no output pulse is generated. Now, these pulses are counted using an electronic counter. The number of pulses generated by the device depends upon two factors, the number of holes in the disc and the speed of the shaft. Since, the number of holes in the disc are fixed, the speed of the shaft is the only input factor. The electronic counter may be therefore, calibrated in terms of speed (rpm). Following is an example of such a tachometer and its operation:

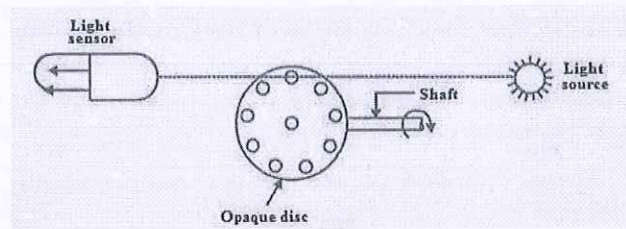

Section – C

1.

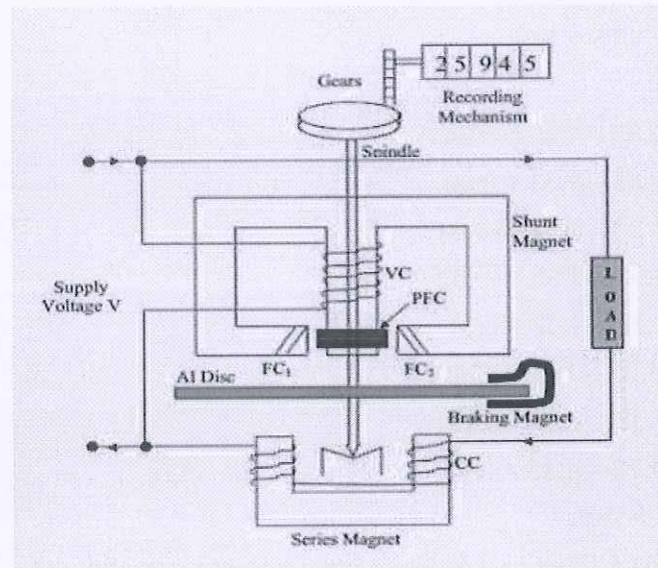

Induction type energy meter essentially consists of following components

- (a) **Driving system:** It consists of two electromagnets, called “shunt” magnet and “series” magnet. **Series magnet:** it consists of a number of U-shaped laminations of silicon steel together to form a core. A coil of thick wire having a few turns is wound in both legs of U-shaped magnet. the coil is known is current coil which is connected series with load to produce the magnetic field proportional and in phase with line current I . **Shunt magnet:** It consists of number of M-shaped laminations of silicon steel assembled together to form a core. A coil of thin wire having large number of turn in wound on central limb of the magnet. this coil is connected across the load. thus it is excited by current proportional to the supply voltage and known is potential coil.
- (b) **Moving system:** The moving system essentially consists of a light rotating aluminium disk mounted on a vertical spindle or shaft. The shaft that supports the aluminium disk is connected by a gear arrangement to the clock mechanism on the front of the meter to provide information that consumed energy by the load. The time varying (sinusoidal) fluxes produced by shunt and series magnet induce eddy currents in the aluminium disc. The interaction between these two magnetic fields and eddy currents set up a driving torque in the disc. The number of rotations of the disk is therefore proportional to the energy consumed by the load in a certain time interval and is commonly measured in **kilowatt-hours (kWh)**.
- (c) **Braking system:** Damping of the disk is provided by a **small permanent magnet**, located diametrically opposite to the a.c magnets. The disk passes between the magnet gaps. The movement of rotating disc through the magnetic field crossing the air gap sets up eddy currents in the disc that reacts with the magnetic field and exerts a braking torque. By changing the

position of the brake magnet or diverting some of the flux there from, the speed of the rotating disc can be controlled.

- (d) Registering system: The function of recording or registering mechanism is to record continuously a number on the dial which is proportional to the revolutions made by the moving system. The no of revolution on the disc is a measured the electrical energy passing through the meter.

2. Mean refractive index is average of eight values i.e.

$$\mu_{\text{mean}} = (1.29 + 1.33 + 1.34 + 1.35 + 1.32 + 1.36 + 1.30 + 1.33) \div 8$$

$$\mu_{\text{mean}} = 10.62 \div 8 = 1.3275 \approx 1.33$$

Absolute error are:

$$\Delta\mu_1 = \mu_{\text{mean}} - \mu_1 = 1.33 - 1.29 = 0.04$$

$$\Delta\mu_2 = \mu_{\text{mean}} - \mu_2 = 1.33 - 1.33 = 0.00$$

$$\Delta\mu_3 = \mu_{\text{mean}} - \mu_3 = 1.33 - 1.34 = -0.01$$

$$\Delta\mu_4 = \mu_{\text{mean}} - \mu_4 = 1.33 - 1.35 = -0.02$$

$$\Delta\mu_5 = \mu_{\text{mean}} - \mu_5 = 1.33 - 1.32 = 0.01$$

$$\Delta\mu_6 = \mu_{\text{mean}} - \mu_6 = 1.33 - 1.36 = -0.03$$

$$\Delta\mu_7 = \mu_{\text{mean}} - \mu_7 = 1.33 - 1.30 = 0.03$$

$$\Delta\mu_8 = \mu_{\text{mean}} - \mu_8 = 1.33 - 1.33 = 0.00$$

Mean Absolute error $\Delta\mu_{\text{mean}}$

$$= (|\Delta\mu_1| + |\Delta\mu_2| + |\Delta\mu_3| + |\Delta\mu_4| + |\Delta\mu_5| + |\Delta\mu_6| + |\Delta\mu_7| + |\Delta\mu_8|) \div 8$$

$$= (0.04 + 0.00 + 0.01 + 0.02 + 0.01 + 0.03 + 0.03 + 0.00) \div 8$$

$$= 0.14 \div 8 = 0.0175 \approx 0.02$$

$$\text{Relative error } (\delta\mu) = \Delta\mu_{\text{mean}} / \mu_{\text{mean}} = 0.02 \div 1.33 = \pm 0.015 \approx 0.02$$

$$\text{Percentage error} = (\Delta\mu_{\text{mean}} / \mu_{\text{mean}}) \times 100\% = \pm 0.015 \times 100 = \pm 1.5$$

3.

1. **Deflecting device**, whereby a mechanical force is produced by the electric current, voltage or power.

2. **Controlling device**, whereby the value of deflection is dependent upon the magnitude of the quantity being measured.

3. **Damping device**, to prevent oscillation of the moving system and enable the latter to reach its final position quickly.

1. **Deflecting Device**. A deflecting device produces a deflecting torque which is caused by anyone of the previously mentioned effects (i.e., thermal effect, chemical effect, electrostatic effect etc.); with the help of this deflecting torque the needle or the pointer moves from zero position to the final position. The arrangement of the deflecting device with each type of instrument will be discussed individually.

2. **Controlling Devices**. There are two types of controlling devices :

(i) Spring control

(ii) Gravity control.

(i) **Spring control**. Fig. 1 shows a commonly used spring control arrangement. It utilizes two spiral hair springs, 1 and 2, the inner ends of which are attached to the spindle *S*. The outer end of spring 2 is fixed while that of 1 is attached to a lever, the adjustment of which gives zero adjustments. The two springs 1 and 2 are wound in opposite directions so that when the moving system is deflected, one spring winds up while the other unwinds, and the controlling torque is due to the combined torsions of the springs.

Since the torsional torque of a spiral spring is proportional to the angle of twist, the controlling torque (T_c) is directly proportional to the angular deflection of the pointer (θ).

i.e., $T_c \propto \theta$

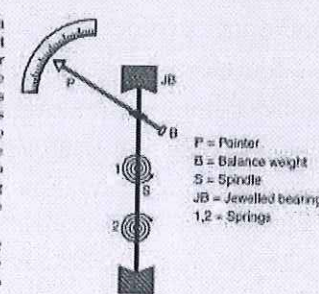

Fig. 1. Spring control.



Answer Key Set – B

Course Code: ELE1304, Course Name: Electrical Measuring Instruments

School of Electrical Skills, Session: 2020-21 (Summer Semester)

B. Voc. Program, III Semester, End-Sem. Examination

4. Electric strike lock:

This facilitates remote access control by monitoring the intruder on video monitor & opening the door remotely. An electric strike is an access control device used for doors. It replaces the fixed strike faceplate often used with a latch bar (also known as a keeper). Like a fixed strike, it normally presents a ramped surface to the locking latch allowing the door to close and latch just like a fixed strike would. However, an electric strike's ramped surface can, upon command, pivot out of the way when lock on door is in the locked position and the door is opened, allowing a user to open the door without operating the mechanical lock or using a mechanical key. After the door is opened past the keeper, keeper returns to its standard position and relocks when power is removed or applied, depending upon strike's configuration.

The electric strike lock typically operates on +12V/950mA supply. Regular mechanical door lock/latch is utilised. It consists of latchable knob which latch automatically when door is pushed to close. It also consists of key to open the latched door from outside. There are two knobs on opposite side of key entry, one is small and other is big. The big knob is used to open door from inside and small knob is used to make the door latch or unlatch permanently. Electric door strike lock allows to open the door by pulling out when 12V supply is applied to its coil. Electric door strike uses regular mechanically operated using keys & turning knob to latch the door from inside. There is a mechanical lever inside strike socket, keep it down for electric latch to operate.

A) Electromagnetic door lock:

An electromagnetic lock, magnetic lock, or maglock is a locking device that consists of an electromagnet and an armature plate. There are two main types of electric locking devices. Locking devices can be either "fail safe" or "fail secure". A fail-secure locking device remains locked when power is lost. Fail-safe locking devices are unlocked when de-energized. Direct pull electromagnetic locks are inherently fail-safe. Typically the electromagnet portion of lock is attached to the door frame and a mating armature plate is attached to door. The two components are in contact when the door is closed. When the electromagnet is energized, a current passing through the electromagnet creates a magnetic flux that causes the armature plate to attract to electromagnet, creating a locking action. Because the mating area of the electromagnet and armature is relatively large, the force created by the magnetic flux is strong enough to keep the door locked even under stress.

Typical single door electromagnetic locks are offered in both 600 lbs (pounds) and 1200 lbs. dynamic holding force capacities. A "fail safe" magnetic lock requires power to remain locked and typically not suitable for high security applications because it is possible to disable the lock by disrupting the power supply. Despite this, by adding a magnetic bond sensor to the lock and by using a power supply that includes a battery backup capability, some specialized higher security applications can be implemented. Electromagnetic locks are well suited for use on emergency exit doors that have fire safety applications because they have no moving parts that are less likely to fail than other types of electric locks, like electric strikes. The strength of today's magnetic locks compares well with that of conventional door locks and they cost less than conventional light bulbs to operate. There are additional pieces of release hardware installed in a typical electromagnetic locking system. Since electromagnetic locks do not interact with levers or door knobs on a door, typically a separate release button that cuts lock power supply is mounted near the door. This button usually has a timer that, once the button is pressed, keeps the lock unlocked for either 15 or 30 seconds in accordance with NFPA (National Fire Prevention Association) fire codes. Additionally, a second release is required by fire code. Either a motion sensor or crash bar with internal switch is used to unlock to door on the egress side of the door automatically. The electromagnetic door lock holds the door in place when 12V supply is applied to its coil.

B) Glass break cum magnetic sensor:

A glass break detector is a sensor used in electronic burglar alarms that detects if a pane of glass is shattered or broken. These sensors are commonly used near glass doors or glass



Answer Key Set – B

Course Code: ELE1304, Course Name: Electrical Measuring Instruments

School of Electrical Skills, Session: 2020-21 (Summer Semester)

B. Voc. Program, III Semester, End-Sem. Examination

store-front windows to detect if an intruder broke the glass and entered. Glass break detectors usually use a microphone, which monitors any noise or vibrations coming from the glass. If the vibrations exceed a certain threshold (that is sometimes user selectable) they are analysed by detector circuitry. Simpler detectors simply use narrowband microphones tuned to frequencies typical of glass shattering, and react to sound above certain threshold, whereas more complex designs compare the sound analysis to one or more glass-break profiles using signal transforms similar to DCT (Discrete Cosine Transform) and FFT (Fast Fourier Transform) and react if both the amplitude threshold and statistically expressed similarity threshold are breached. Glass break sensor consists of 2 separate sensors inside but common NC (Normally Closed) output contact. Magnetic reed switch combination as before when door opens, reed switch contact becomes open disconnecting further circuit.



School of Electrical Skills
Session: 2020-21 (Summer Semester)
B. Voc. Program, 3rd Semester,
End -Sem. Examination

Course Code: ELE1305

Time: 2 Hours

Course Name: Introduction of Power System

Max. Marks: 50

Instructions: Answer all questions from section A, each question carries one mark. Answer all questions from section B, each question carries four marks. Answer all questions from section C, each question carries six marks. Scientific calculator is allowed.

Section – A

10x01 = 10 Marks

- When alternating current passes through a conductor?
(a) it remains uniformly distributed throughout the section of conductor
(b) portion of conductor near the surface carries more current as compared to the core
(c) portion of conductor near the surface carries less current as compared to the core
(d) entire current passes through the core of the conductor.
- Which of the following is usually not the generating voltage?
(a) 6.6 kV (b) 9.9 kV (c) 11kV (d) 13.2 kV.
- Skin effect depends on:
(a) size of the conductor (b) frequency of the current
(c) resistivity of the conductor material (d) all of the above.
- As compared with the HVAC lines, dc transmission system is free from:
(a) inductance (b) Capacitance
(c) phase displacement (d) all of the mentioned
- Which among these HVDC projects are commissioned in India?
(a) Rihand – Delhi HVDC (b) Vindhyachal Back to Back only
(c) Chandrapur only (d) All of these
- Which process is responsible for production of energy in the Nuclear power plant?
(a) Nuclear fission reaction (b) Nuclear fusion reaction
(c) Exothermal chemical reaction (d) All of these
-requires more space.
(a) Nuclear power plant (b) Hydro-electric power plant
(c) Thermal power plant (d) Diesel power plant
- Which of the following is not a requirement for site selection of hydroelectric power plant?
(a) Availability of water (b) Large catchment area
(c) Rocky land (d) Sedimentation
- Thermal power plant is _____
(a) Non-renewable source of energy (b) Conventional source of energy
(c) Non-conventional source of energy (d) Continuous source of energy
- The fuel used in Nuclear power plant is:
(a) Uranium (b) Thorium (c) radium (d) coal

Sumit
A



Section – B

04x04 = 16 Marks

1. Write a brief comparison between thermal, hydro and nuclear power plant.
2. Explain the terms isolator, current transformer, potential transformer and lightning arrester.
3. Write the disadvantages of thermal power plant.
4. Define Skin effect.

Section – C

04x06 = 24 Marks

1. What are the different type of circuit breaker? Explain any one in detail.
2. What is Ferranti Effect? Discuss why it is occurring and how it is reducing.
3. Draw and explain the layout of solar power plant.
4. What are the functions of feed water heater, economizer and air preheater?



BHARTIYA SKILL DEVELOPMENT UNIVERSITY

School of Electrical Skills
Session: 2020-21 (Summer Semester)
B. Voc. Program, 3rd Semester,
End -Sem. Examination

Course Code: ELE1305

Time: 2 Hour

Course Name: Introduction of Power System

Max. Marks: 50

Section – A

10X01 = 10 Marks

- When alternating current passes through a conductor
(a) it remains uniformly distributed throughout the section of conductor
(b) portion of conductor near the surface carries more current as compared to the core
(c) portion of conductor near the surface carries less current as compared to the core
(d) entire current passes through the core of the conductor.
- Which of the following is usually not the generating voltage?
(a) 6.6 kV **(b) 9.9 kV** (c) 11kV (d) 13.2 kV.
- Skin effect depends on
(a) size of the conductor (b) frequency of the current
(c) resistivity of the conductor material **(d) all of the above.**
- As compared with the HVAC lines, dc transmission system is free from _____
(a) inductance (b) Capacitance
(c) phase displacement **(d) all of the mentioned**
- Which among these HVDC projects are commissioned in India?
(a) Rihand – Delhi HVDC (b) Vindhyachal Back to Back only
(c) Chandrapur only **(d) All of these**
- Which process is responsible for production of energy in the Nuclear power plant?
(a) Nuclear fission reaction (b) Nuclear fusion reaction
(c) Exothermal chemical reaction (d) All of the above
-requires more space
(a) Nuclear power plant **(b) Hydro-electric power plant**
(c) Thermal power plant (d) Diesel power plant
- Which of the following is not a requirement for site selection of hydroelectric power plant?
(a) Availability of water (b) Large catchment area
(c) Rocky land **(d) Sedimentation**
- Thermal power plant is _____
(a) Non-renewable source of energy **(b) Conventional source of energy**
(c) Non-conventional source of energy (d) Continuous source of energy
- The fuel used in Nuclear power plant is.....
(a) Uranium (b) Thorium (c) radium (d) coal



Section – B

04X04 = 16 Marks

1. Write a brief comparison between thermal, hydro and nuclear power plant.

Thermal Power Station

Principle of operation: It works on Modified Rankine Cycle.

Location: It is located at a site where coal, water and transportation facilities are available easily. It is located near load centers.

Requirement of Space: Need a large space due to coal storage, turbine, boiler and other auxiliaries.

Efficiency: Overall efficiency is least compared to other plants. (30%-32%)

Fuel Used: Coal (mostly) or oil.

Availability of Fuel: Coal reserves are present all over the world. However, coal is non-renewable and limited.

Cost of Fuel: High. Coal is heavy and has to be transported to the plant.

Initial Cost of Plant: Lower than Hydroelectric and Nuclear power plants.

Running Costs: Higher than Hydroelectric and Nuclear power plants.

Maintenance Costs: High. Skilled engineers and staff are needed.

Transmission and Distribution Cost: Low. It is usually located near load centers.

Start-up Power: About 10% of unit capacity.

Starting time: Large

Standby Losses: More than hydroelectric and nuclear power plants. Boiler flame has to be kept burning, so some amount of coal is used constantly, even when the turbine is not in operation.

Cleanliness: Less clean. Smoke and ash are produced.

Environmental Considerations: Air pollution occurs and leads to acid rain. Greenhouse gases are also produced.

Life Time: 30 - 40 years.

Hydroelectric Power Plant

Principle of operation: Potential energy of water is converted to Kinetic energy and used to rotate a turbine.

Location: Located where a large amount of water can be collected easily in a reservoir by constructing a dam. Usually in a hilly area at high altitude.

Requirement of Space: Very large space required. A dam is huge.

Efficiency: As high as 85% to 90%

Fuel Used: Water

Availability of Fuel: Availability of water is unreliable because it depends on the weather (rainfall.)

Cost of Fuel: Water is free.

Initial Cost of Plant: Very high. Construction of a dam and reservoir is expensive.

Running Costs: Zero, because no fuel is needed.

Maintenance Costs: Low.

Transmission and Distribution Cost: High. It is located in remote areas, away from load centers.

Start-up Power: 0.5% to 1% of unit capacity.

Starting time: Low. Can be started instantly.

Standby Losses: None.

Cleanliness: Clean.

Environmental Considerations: Affects marine life. People in the region have to be relocated.

Life Time: Large (50 to 100 years.)

Nuclear Power Plant

Principle of operation: Thermonuclear fission.

Location: Located away from heavily populated areas.

Requirement of Space: Requires minimum space compared to other plants of the same capacity.

Efficiency: Higher than Thermal Power Station. About 55%

Fuel Used: Uranium (U235) and other radioactive metals.

Availability of Fuel: Deposits of nuclear fuel are present all over the world. Also, uranium can be extracted from sea water, but it's a complicated and complex process.

Cost of Fuel: Fuel (uranium) itself isn't too costly. However, if enriched uranium is used, then the cost of fuel increases considerably. A small amount of fuel is used, so transportation costs are less.

Initial Cost of Plant: Highest. A nuclear reactor is complex and requires the most skilled engineers.

Running Costs: Small amount of fuel used, so running cost is low.

Maintenance Costs: Very high. Skilled personnel are needed.

Transmission and Distribution Cost: Quite low. Such plants can be located near the load centers.



Start-up Power: 7% to 10% of unit capacity.

Starting time: Less than TPS. Can be started easily.

Standby Losses: Less.

Cleanliness: Radioactive waste is produced. Less clean than HPS.

Environmental Considerations: Disposal of radioactive wastes may affect the environment, especially if it is buried underground. Underwater contamination may occur.

Life Time: 40-60 years.

2. Explain the terms isolator, current transformer, potential transformer and lightning arrester.

Isolator :

- It is a disconnection switch and to be operated on no load.
- It is used to make sure that an electrical circuit can be completely de-energized for service or maintenance.
- It provide electrical isolation of the equipment .
- For voltages up to 145 KV system hand operated isolators are used.

CT is a type of instrument transformer that is used in power system for measurement, detection, protection of the system.

Current transformers are used extensively for measuring current and monitoring the operation of the power grid.

Potential transformers are instrument transformers. They have a large number of primary turns and a few number of secondary turns.

It converts voltages from high to low. It will take the thousands of volts behind power transmission systems and step the voltage down to something that meters can handle.

Lightning Arresters: It discharge the over voltage surges to earth and protect the equipment insulation from switching surges and lightning surges.

It located at the starting of the substation as seen from incoming transmission lines and is the first equipment of the substation

3. Write the disadvantages of thermal power plant.

- It pollutes the atmosphere due to producing large amount of smoke and fumes.
- Higher maintenance cost and operational cost.
- Huge requirement of water.

4. Define Skin effect.

The non-uniform distribution of electric current over the surface or skin of the conductor carrying a.c is called the skin effect. In other words, the concentration of charge is more near the surface as compared to the core of the conductor. The ohmic resistance of the conductor is increased due to the concentration of current on the surface of the conductor.

Skin effect increases with the increase in frequency. At low frequency, such as 50Hz, there is a small increase in the current density near the surface of the conductor; but, at high frequencies, such as radio frequency, practically the whole of the currents flows on the surface of the conductor. If d.c current (frequency=0) is passed in a conductor, the current is uniformly distributed over the cross-section of the conductors.

Section – C

04X06 = 24 Marks

1. What are the different type of circuit breaker? Explain any one in detail.

Ans: Types of Circuit Breaker



Circuit breakers are mainly classified on the basis of rated voltages. Circuit breakers below rated voltage of 1000V are known as the low voltage circuit breakers and above 1000V are called the high voltage circuit breakers.

The most general way of the classification of the circuit breaker is on the basis of the medium of arc extinction. Such types of circuit breakers are as follows :-

1. Oil Circuit Breaker
 - Bulk Oil Circuit Breaker
 - Minimum Oil Circuit Breaker
 2. Minimum Circuit Breaker
 3. Air Blast Circuit Breaker
 4. Sulphur Hexafluoride Circuit Breaker
 5. Vacuum Circuit Breaker
 6. Air Break Circuit Breaker
2. What is Ferranti Effect? Discuss why it is occurring and how it is reducing.

Ans: Definition: The effect in which the voltage at the receiving end of the transmission line is more than the sending voltage is known as the Ferranti effect. Such type of effect mainly occurs because of light load or open circuit at the receiving end.

Ferranti effect is due to the charging current of the line. When an alternating voltage is applied, the current that flows into the capacitor is called charging current. A charging current is also known as capacitive current. The charging current increases in the line when the receiving end voltage of the line is larger than the sending end.

Why Ferranti effect occurs?

Capacitance and inductance are the main parameters of the lines having a length 240km or above. On such transmission lines, the capacitance is not concentrated at some definite points. It is distributed uniformly along the whole length of the line.

When the voltage is applied at the sending end, the current drawn by the capacitance of the line is more than current associated with the load. Thus, at no load or light load, the voltage at the receiving end is quite large as compared to the constant voltage at the sending end.

How to reduce Ferranti effect:

BHARTIYA SKILL DEVELOPMENT UNIVERSITY



Electrical devices are designed to work at some particular voltage. If the voltages are high at the user ends their equipment get damaged, and their windings burn because of high voltage. Ferranti effect on long transmission lines at low load or no load increases the receiving end voltage.

This voltage can be controlled by placing the shunt reactors at the receiving end of the lines.

Shunt reactor is an inductive current element connected between line and neutral to compensate the capacitive current from transmission lines. When this effect occurs in long transmission lines, shunt reactors compensate the capacitive VAR of the lines and therefore the voltage is regulated within the prescribed limits.

3. Draw and explain the layout of solar power plant.

Solar power works by converting light from the sun into electricity. This electricity can then be used in your home or exported to the grid when it's not needed. This is done by installing solar panels on your roof which generate DC (Direct Current) electricity. This is then fed into a solar inverter which converts the DC electricity from your solar panels into AC (Alternating Current) electricity.

Your solar panels are made up of silicon photovoltaic (PV) cells. When sunlight hits your solar panels, the solar PV cells absorb the sunlight's rays and electricity is produced via the Photovoltaic Effect. The electricity produced by your panels is called Direct Current (DC) electricity, and which is not suitable to be used in your home by your appliances. Instead, the DC electricity is directed to your central inverter (or micro inverter, depending on your system set up).

2. Your inverter is able to convert the DC electricity into Alternating Current (AC) electricity, which can be used in your home. From here, the AC electricity is directed to your switchboard.

3. A switchboard allows your usable AC electricity to be sent to the appliances in your home. Your switchboard will always ensure that your solar energy will be used first to power your home, only accessing additional energy from the grid when your solar production is not enough.

4. All households with solar are required to have a bi-directional meter (utility meter), which your electricity retailer will install for you. A bi-directional meter is able to record all the power that is drawn to the house, but also record the amount of solar energy that is exported back to the grid. This is called net-metering.

5. Any unused solar electricity is then sent back to the grid. Exporting solar power back to the grid will earn you a credit on your electricity bill, called a feed-in tariff (FiT). Your electricity bills will then take into account the electricity you purchase from the grid, plus credits for the electricity generated by your solar power system that you don't use.

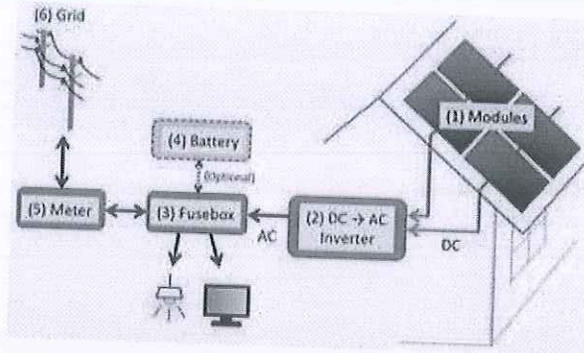

4. What are the functions of feed water heater, economizer and air preheater?

AIR PREHEATER

The function of air preheaters is to preheat the air before entering to the furnace by utilizing some of the energy left in the flue gases before exhausting them to the atmosphere.

After flue gases leave economizer, some further heat can be extracted from them and used to heat incoming heat. Cooling of flue gases by 20 degree centigrade increases the plant efficiency by 1%.

ECONOMIZER

Flue gases coming out of the boiler carry lot of heat. An economizer extracts a part of this heat from flue gases and uses it for heating feed water. Saving coal consumption and higher boiler efficiency.

FEED WATER HEATER

Feed water heating improves overall plant efficiency.
Thermal stresses due to cold water entering the boiler drum are avoided.
Quality of steam produced by the boiler is increased.



BHARTIYA SKILL DEVELOPMENT UNIVERSITY

Reg. No. _____

School of Electrical Skills
Session: 2020-21 (Summer Semester)
B. Voc. Program, 3rd Semester,
End -Sem. Examination

Course Code: ELE1305

Time: 2 Hour

Course Name: Introduction of Power System

Max. Marks: 50

Instructions: Answer all questions from section A, each question carries one mark. Answer all questions from section B, each question carries four marks. Answer all questions from section C, each question carries six marks. Scientific calculator is allowed.

Section – A

10x01 = 10 Marks

- The cost of fuel transportation is maximum in:
(a) Hydro-electric power plant (b) Steam power plant
(c) Nuclear power plant (d) Diesel power plant
- Current transformers and potential transformers are used to increase the ranges of:
(a) AC ammeter and AC voltmeter respectively
(b) AC ammeter and DC voltmeter respectively
(c) DC ammeter and DC voltmeter respectively
(d) DC ammeter and AC voltmeter respectively
- Ground resistance should be designed such that:
(a) grounding resistance should be as low as possible
(b) grounding resistance should be as high as possible
(c) grounding resistance should be always zero
(d) none of the above
- A transmission and distribution engineer needed to design the sub transmission substation. The tapping component needed will be:
(a) feeder (b) distributor (c) transmitter (d) tap-changing transformer
- Skin effect depends on:
(a) size of the conductor (b) frequency of the current
(c) resistivity of the conductor material (d) all of these
- Moisture content in the soilthe earth soil resistance.
(a) increase (b) decrease (c) does not affect (d) none of these
- Nuclear fuel in reactor lasts for _____
(a) more than 5 months (b) few weeks (c) few days (d) more than 5 years
- A steam power station requires space.....
(a) Equal to diesel power station (b) More than diesel power station
(c) More than diesel power station (d) None of these
- Current transformers are _____
(a) series connected type of instrument transformers
(b) parallel connected type of instrument transformers
(c) series-parallel connected type of instrument transformers
(d) parallel connected normal transformers

Signature
B



1. Define Ferranti effect.

Definition: The effect in which the voltage at the receiving end of the transmission line is more than the sending voltage is known as the Ferranti effect. Such type of effect mainly occurs because of light load or open circuit at the receiving end.

Ferranti effect is due to the charging current of the line. When an alternating voltage is applied, the current that flows into the capacitor is called charging current. A charging current is also known as capacitive current. The charging current increases in the line when the receiving end voltage of the line is larger than the sending end.

2. Explain the terms isolator, current transformer, potential transformer and lightning arrester.

Isolator :

- It is a disconnection switch and to be operated on no load.
- It is used to make sure that an electrical circuit can be completely de-energized for service or maintenance.
- It provide electrical isolation of the equipment .
- For voltages up to 145 KV system hand operated isolators are used.

CT is a type of instrument transformer that is used in power system for measurement, detection, protection of the system.

Current transformers are used extensively for measuring current and monitoring the operation of the power grid.

Potential transformers are instrument transformers. They have a large number of primary turns and a few number of secondary turns.

It converts voltages from high to low. It will take the thousands of volts behind power transmission systems and step the voltage down to something that meters can handle.

Lightning Arresters: It discharge the over voltage surges to earth and protect the equipment insulation from switching surges and lightning surges.

It located at the starting of the substation as seen from incoming transmission lines and is the first equipment of the substation

3. Classify different distribution system. Explain any one in detail

There are four distribution feeder systems are used

- Radial
- Parallel feeders
- Ring main
- interconnected systems

4. Describe the corona effect.

Definition: The phenomenon of ionisation of surrounding air around the conductor due to which luminous glow with hissing noise is rise is known as the corona effect.

Air acts as a dielectric medium between the transmission lines. In other words, it is an insulator between the current carrying conductors.

The electric field intensity also increases because of the charging current. If the intensity of the electric field is less than 30kV, the current induces between the conductor is neglected. But if the voltage rise beyond the 30kv then the air between the conductors becomes charge and they start conducting. The sparking occurs between the conductors till the complete breakdown of the insulation properties of conductors takes place.

Section – C

04X06 = 24 Marks

1. Draw and explain the single line diagram of power supply system.

BHARTIYA SKILL DEVELOPMENT UNIVERSITY

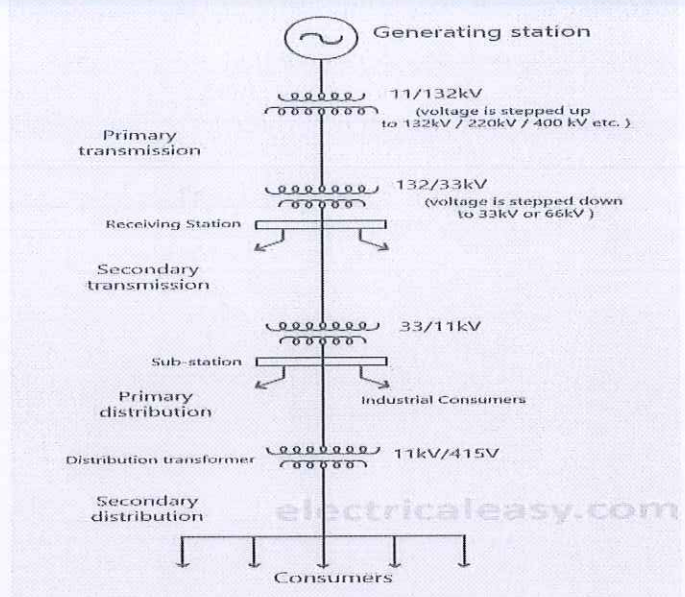

Electrical power is normally generated at 11kV in a power station. While in some cases, power may be generated at 33 kV.

This generating voltage is then stepped up to 132kV, 220kV, 400kV or 765kV etc. Stepping up the voltage level depends upon the distance at which power is to be transmitted. Longer the distance, higher will be the voltage level. Stepping up of voltage is to reduce the I^2R losses in transmitting the power (when voltage is stepped up, the current reduces by a relative amount so that the power remains constant, and hence I^2R loss also reduces). This stage is called as primary transmission.

The voltage is the stepped down at a receiving station to 33kV or 66kV. Secondary transmission lines emerge from this receiving station to connect substations located near load centers (cities etc.).

The voltage is stepped down again to 11kV at a substation. Large industrial consumers can be supplied at 11kV directly from these substations. Also, feeders emerge from these substations. This stage is called as primary distribution.

Feeders are either overhead lines or underground cables which carry power close to the load points (end consumers) up to a couple of kilometers.

Finally, the voltage is stepped down to 415 volts by a pole-mounted distribution transformer and delivered to the distributors.

2. Compare grounding and earthing of a system.

Comparison Chart

Basis For Comparison	Grounding	Earthing
Definition	The current carrying part is connected to ground.	The body of the equipment is connected to ground.
Location	Between the neutral of the equipment and ground	Between the equipment body and earth pit which is placed under the earth surface.
Symbol		
Zero Potential	Does not have	Have
Protection	Protect the power system equipment.	Protect the human from electric shock.
Application	Provide the return path to the current.	It discharges the electrical energy to the earth.

3. Draw the layout of thermal power plant and explain the function of :

- (i) Coal handling plant (ii) Air preheater

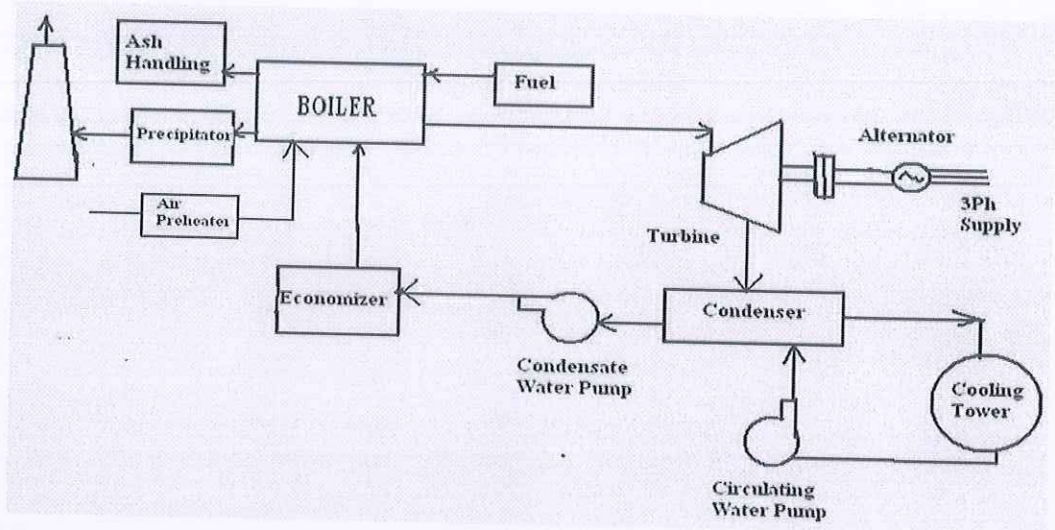

COAL HANDLING PLANT

Coal is transported to power station by rail or road and stored in coal storage plant and then pulverized. A 200MW plant may require around 2000 tons of coal daily.

AIR PREHEATER

The function of air preheaters is to preheat the air before entering to the furnace by utilizing some of the energy left in the flue gases before exhausting them to the atmosphere.

After flue gases leave economizer, some further heat can be extracted from them and used to heat incoming heat. Cooling of flue gases by 20 degree centigrade increases the plant efficiency by 1%.

4. Compare HVDC and HVAC transmission system.

COMPARISON OF HVAC & HVDC SYSTEMS

- HVAC transmission is having several limitations like line length , uncontrolled power flow, over/low voltages during lightly / over loaded conditions, stability problems, fault isolation etc
- The advantage of HVDC is the ability to transmit large amounts of power over long distances with lower capital costs and with lower losses than AC.
- Asynchronous operation possible between regions having different electrical parameters .
- Facilitate power transmission between different countries that use AC at differing voltages and/or frequencies
- Reducing line cost:
 - fewer conductors
 - thinner conductors since HVDC does not suffer from the skin effect

- Lesser Corona Loss than HVAC at same voltage and conductor diameter and less Radio interference.
- Direction of power flow can be changed very quickly
- HVDC has greater reliability. i.e. bipolar dc is more reliable than 3 phase HVAC
- DC requires less insulation.
- An optimized DC link has smaller towers than an optimized AC link of equal capacity.