

THEORY 1 st - IN-SEM EXAMINATION			
SESSION: 2022-23 (SUMMER SEMESTER)			
B.Voc	Semester		3 rd
Course name	Automation & Control		
Course code	ELE 1301		
Date			
Name of the Student		Reg. No.	

INSTRUCTIONS

- Maximum Marks: **20**
- Duration of Examination: **01 Hour**
- Attempt all questions.

1. Section A (05 objective type questions, each question carries 01 mark)

05×1 = 05

- In the _____ we use the hydraulic and liquid pressure for control the process.
 - Hard wired controlling
 - Pneumatic controlling
 - Logic gate controlling
 - None of these
- The Father of PLC is: -
 - Richard E-Morley
 - D. S. Harder
 - Heron
 - None of these
- A sourcing proximity switch can only interface with a _____ PLC input channel.
 - Sinking
 - Sourcing
 - Both a and b
 - None of these
- The full form of SMPS is: -
 - Single Module Power Supply
 - Single Module Power Switch
 - Switch Mode Power Supply
 - None of These
- Hold up time when PLC can tolerate a power loss.
 - 3 second to 10 second
 - 10 second to 1 minute
 - 5 millisecond to 50 millisecond
 - 10 millisecond to 3 second

2. Section B (03 short answer type questions, each question carries 02 marks)

03×02 = 06

- Write short note on pneumatic controlling.
- What are the advantages of PLC ?
- What is the difference between sinking and sourcing ?

3. Section C (03 long type questions, each question carries 03 marks)

03×03 = 09

- Explain the need and role of automation.
- Explain the Architecture of PLC with diagram.
- Differentiate the hardwired logic (Relay logic) versus programmed logic.



THEORY 1 st - IN-SEM EXAMINATION		
SESSION: 2022-23 (SUMMER SEMESTER)		
B.Voc	Semester	3 rd
Course name	Automation & Control	
Course code	ELE 1301	

1. Section A (05 objective type questions, each question carries 01 mark)	05×1 = 05
--	------------------

- In the _____ we use the hydraulic and liquid pressure for control the process.
(b) Pneumatic controlling
- The Father of PLC is: -
(a) Richard E-Morley
- A sourcing proximity switch can only interface with a _____ PLC input channel.
(a) Sinking
- The full form of SMPS is: -
(c) Switch Mode Power Supply
- Hold up time when PLC can tolerate a power loss.
(d) 10 millisecond to 3 second

2. Section B (03 short answer type questions, each question carries 02 marks)	03×02 = 06
--	-------------------

1. Write short note on pneumatic controlling.

Ans. A pneumatic system is a collection of interconnected components using compressed air to do work for automated equipment. In this case the use of a gaseous media under pressure to generate, transmit and control power; Hydraulics is another form of fluid power, which uses a liquid media such as oil EX. Hydraulic gates.

2. What are the advantages of PLC.

Ans. Advantages of PLC

- Increased Reliability
- More flexibility
- Lower cost
- Communication capability
- Faster Response time
- Easier to troubleshoot

3. What is the difference between sinking and sourcing.

Ans. The terms "sourcing" and "sinking" refer to the direction of current (as denoted by conventional flow notation) into or out of a device's control wire. A device sending (conventional flow) current out of its control terminal to some other device(s) is said to be sourcing current, while a device accepting (conventional flow) current into its control terminal is said to be sinking current.

3. Section C (03 long type questions, each question carries 03 marks)

03×03 = 09
1. Explain the need and role of automation.
Ans. Need and role of automation

- Reduce Worker Fatigue and Effort or Labour Intensive Operation:** Typically, humans dislike banal, repetitive tasks. However, computer systems perform them without complaint.
- Prevent Products or Materials from Being Damaged or Destroyed:** Humans make mistakes when they fatigue. This embodies the sentiment of the "human condition." Mistakes using tools mean damaging raw materials, components, assemblies, and end products.
- Prevent Non-Conforming Product from Shipping:** Computers controlling robots do not forget steps. Neglecting to put in a screw requires a human touch.
- Increase Efficiency:** Improving processes for efficiency makes a company more competitive, but do people always do the same thing, in the same way, every time they do it? No, human variation exists. Automated systems allow for improvements that benefit from consistent execution.
- Collect Better Data:** Remove the accidental data entry or missed data point from logging. Different sensors regulate it.
- Improve Metrics:** Sending reliable data directly to a database provides an ongoing resource. Correlation of associated process data with pass/fail records provides insight rather than guessing "what is causing this?".
- Devise the Right Process Improvements:** Automated systems now collect reliable data. The database provides a searchable forum. It makes "continuous improvement," make changes with better information.
- Save Money:** Cost savings through making processes more regular and collecting data for making confident decisions.

2. Explain the Architecture of PLC with diagram.

Ans. Input module accepts signals from sensors or buttons and convert signal into a logic signal.

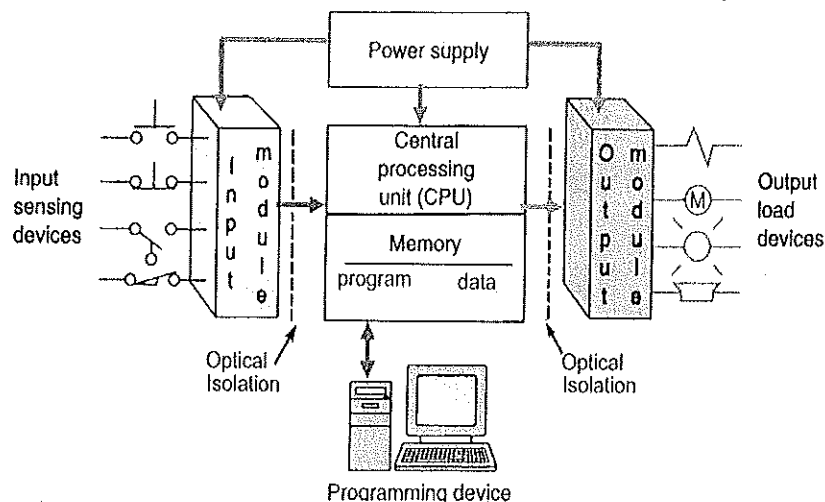

example: switches, push buttons, sensors etc.

Output module convert control instructions or logic into mechanical output signal that can be used by output devices. example: lamps, alarm etc.

Power supply: - It Provides the particular voltage needed to run the primary PLC components.

Relay: - Relays are switches that open and close circuits electromechanically. Relays control one electrical circuit by opening and closing contacts in another circuit.

Processor module consists of the central processing unit (CPU) and memory. In addition to a micro-processor, the CPU also contains at least an interface to a programming device and may contain interfaces to remote I/O and other communication networks.

Programing device is used to develop, Download and upload the ladder logic program into the processor of PLC.

3. Differentiate the hardwired logic (Relay logic) versus programmed logic.

Ans. Hardwired logic can be implemented using relays and relay ladder schematics. Relay ladder schematics are universally used and understood in industry. All the components are placed between these two lines, called rails or legs, connecting the two power lines with what look like rungs of a ladder—thus the name, relay ladder schematic. Hardwired logic is fixed; it is changeable only by altering the way devices are electrically interconnected. In contrast, programmable control is based on the basic logic functions, which are programmable and easily changed. The form in which these instructions are implemented to convey commands to the PLC is called the language. The most common PLC language is ladder logic

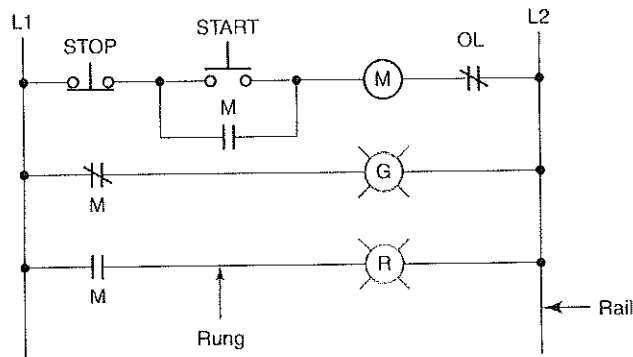

Fig. Motor stop/start relay ladder schematic.

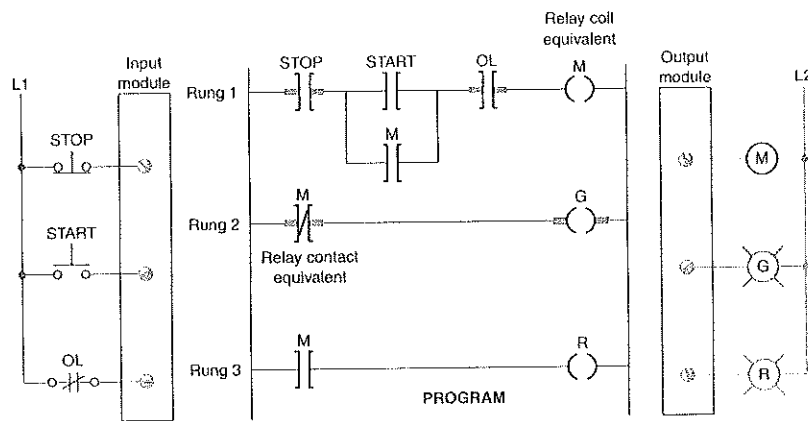

Fig. Motor stop/start ladder logic program.



THEORY 1 ST - IN-SEM EXAMINATION			
SESSION: 2022-23(SUMMER SEMESTER)			
B.Voc	Semester	3 rd	
Course name	Electrical Measuring Instruments		
Course code	ELE1304		
Date			
Name of the Student		Reg. No.	

INSTRUCTIONS
<ul style="list-style-type: none"> • Maximum Marks: 20 • Duration of Examination: 01 Hour • Attempt all questions.

1. Section A (05 objective type questions, each question carries 01 mark)	05×1 = 05
--	------------------

- LDR sensor used for?
(a) motion detect (b) resistance detect (c) light detect (d) voltage detect
- Unit of Energy is:
(a) KWH (b) Ohm (c) voltage (d) all of these
- Current of any circuit can be measured:
(a) in series (b) in parallel (c) either series or parallel (d) none of these
- What does a tachometer measure?
(a) voltage (b) current (c) speed (d) distance
- Phase rotation meter is used for?
(a) voltage measurement (b) current measurement (c) phase direction measurement (d) all of these

2. Section B (03 short answer type questions, each question carries 02 marks)	03×02 = 06
--	-------------------

- Write the Advantages of Electrical Measuring Instruments.
- Write the Methods of minimization or elimination of errors.
- What is Electrical Measurements?

3. Section C (03 long type questions, each question carries 03 marks)	03×03 = 09
--	-------------------

- Explain About Any 3 Sensors.
- What is Restoring Torque?
- Explain the types of Measurement Errors.

Signature



Answers Key

Course Code: ELE1304 Course Name: Electrical Measuring Instruments
School of Electrical Skills, Session: 2022-23 (Summer Semester)
B. Voc. Program, III Semester, 1st In-Sem. Examination

Section – A

05X01 = 05 Marks

1. (c)
2. (a)
3. (a)
4. (c)
5. (c)

Section – B

03X02 = 06 Marks

1. They are reliable all the times
They are more power efficient
They are more portable in the sense
They can be moved around easily
They can be used in a variety of power supply all over the world.
2. Make sure the formulas used for measurement are correct
Cross check the measured value of a quantity for improved accuracy.
Use the instrument that has the highest precision.
It is suggested to pilot test measuring instruments for better accuracy.
Use multiple measures for the same construct. Note the measurements under controlled conditions.
3. Electrical measurements are the methods, devices and calculations used to measure electrical quantities. Measurement of electrical quantities may be done to measure electrical parameters of a system.
Example: Voltage, Current, Power, Resistance, Frequency etc.

Section – C

03X03 = 09 Marks

1. LDR sensors = a Light Dependent Resistor (LDR) is also called a photo-resistor or a cadmium sulphide cell. It is also called a photoconductor. ... This optoelectronic device is mostly used in light varying sensor circuit, and light and dark activated switching circuits.

Motion sensor = a motion sensor, or motion detector, is an electronic device that uses a sensor to detect nearby people or objects.

Smoke sensor = a smoke detector is an electronic fire-protection device that automatically senses the presence of smoke.
2. Restoring Torque = Without controlling torque the pointer will swing at its maximum position & will not return to zero after removing the source. Controlling torque is produced either by spring or gravity control.
3. Gross Errors = These are basically human errors which may include misreading of the instruments, incorrect adjustment, improper application of instrument
Random Errors = The random errors are those errors, which occur irregularly and hence are random. These can arise due to random and unpredictable fluctuations in experimental conditions (Example: unpredictable fluctuations in temperature, voltage supply, mechanical vibrations of experimental set-up, errors by the observer taking readings, etc. For example, when the same person repeats the same observation, it is very likely that he may get different readings every time.
Systematic Errors =
These errors can be divided into three different categories.
 1. Instrumental errors
 2. Environmental errors
 3. Observational errors

THEORY 1 st - IN-SEM EXAMINATION			
SESSION: 2022-23(SUMMER SEMESTER)			
B.Voc	Semester	3 rd	
Course name	Introduction to Power System		
Course code	ELE 1305		
Date			
Name of the Student			Reg. No.

INSTRUCTIONS
<ul style="list-style-type: none"> • Maximum Marks: 20 • Duration of Examination: 01 Hour • Attempt all questions. • Scientific Calculator is allowed.

1. Section A (05 objective type questions, each question carries 01 mark)	05×1 = 05
--	------------------

- Up to 33KV which type of insulator is preferred
 - Suspension Type
 - Pin type
 - Strain Type
 - Shackle
- For a 132kV line what will be the number of disc in a suspension type insulator
 - ~12
 - ~15
 - ~20
 - None of them
- Coal is a type of :
 - Conventional Source of Energy
 - Non- Conventional Source of Energy
 - Renewable Source of Energy
 - None of the above
- The heart of Power System is :
 - Generator
 - Transmission line
 - Distribution system
 - Consumers
- "Generator is a component used to change the voltage level without changing frequency". True or False
 - True
 - False

2. Section B (03 short answer type questions, each question carries 02 marks)	03×02 = 06
--	-------------------

- Define Generating Substation.
- Draw a neat and clean Single line diagram of Power System having various substations labelled.
- What should be the properties of a good insulator?

3. Section C (03 long type questions, each question carries 03 marks)	03×03 = 09
--	-------------------

- Draw a neat and clean layout of Thermal Power Plant with each component clearly mentioned on it.
- Explain Conventional and Non Conventional Sources of Energy with suitable example
- Write Short note on
 - Porcelain Insulator
 - Glass Insulator
 - Suspension type Insulator





Answers Key

Course Code: ELE1305, Course Name: Introduction to Power System
School of Electrical Skills, Session: 2022-23 (Summer Semester)
B. Voc. III Semester, End-Sem. Examination

SECTION A

- (b) Pin type
- (a) ~12
- (a) Conventional Source of Energy
- (a) Generator
- (b) False

Section – B

02X03 = 6 Marks

1. Define Generating Substation.

Answer: Generating Substation: In generating station the fuel (coal, water, nuclear energy, etc.) is converted into electrical energy. The electrical power is generated in the range of 11kV to 25kV, which is step-up for long distance transmission.

The generator and the transformer are the main components of the generating station. The generator converts the mechanical energy into electrical energy.

The transformer transfers the power with very high efficiency from one level to another. The power transfer from the secondary is approximately equal to the primary except for losses in the transformer. The step-up transformer will reduce losses in the line which makes the transmission of power over long distances.

2. Draw a neat and clean Single line diagram of Power System having various substations labelled.

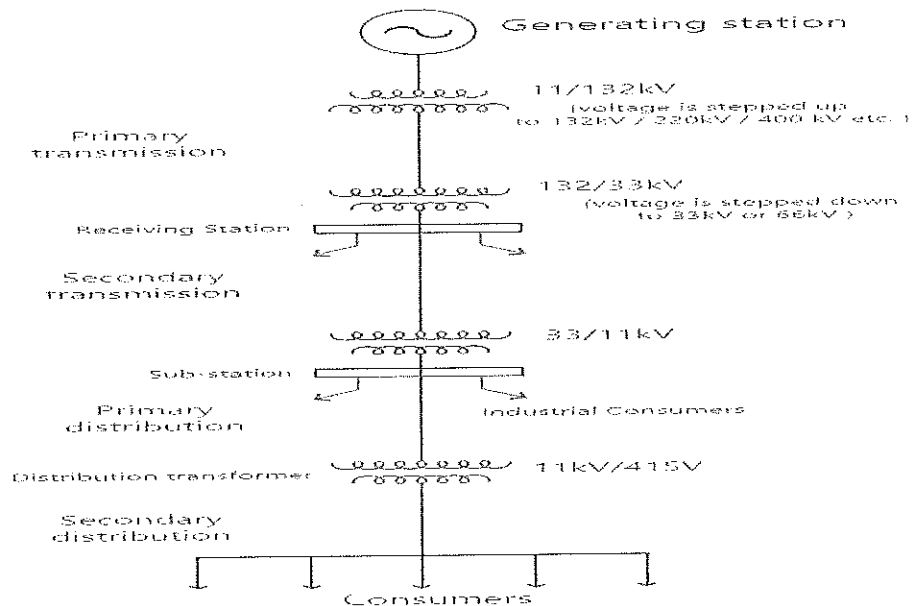

3. What should be the properties of a good insulator? What are the advantages of glass insulators over porcelain insulators?

Answer: Following should be properties of good insulators

- high mechanical strength in order to withstand the conductor load, wind load etc.
- high electrical resistance in order to minimize the leakage currents.
- high relative permittivity of insulating material so that the dielectric strength is high
- high ratio of puncture strength to flashover.

Section – C

03X03 = 09 Marks

- Draw a neat and clean layout of Thermal Power Plant with each component clearly mentioned on it.

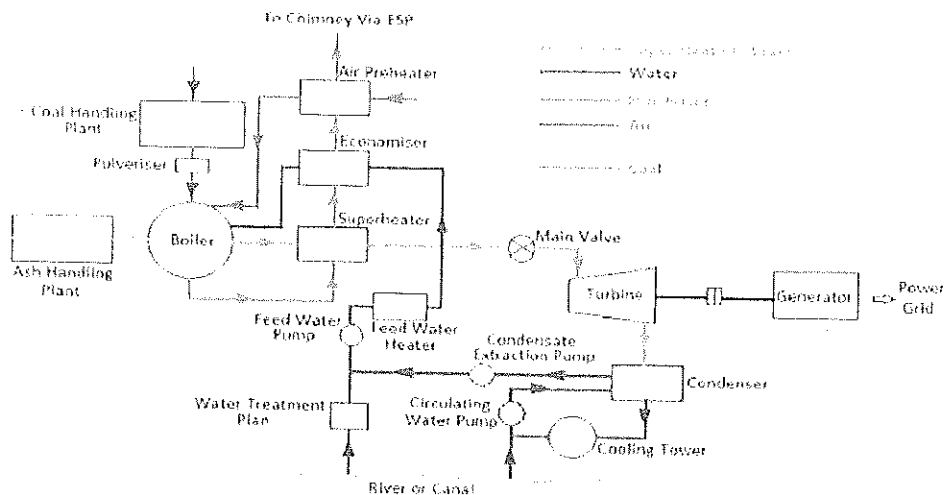

2. Explain Conventional and Non Conventional Sources of Energy with suitable example:

Conventional Sources:
 Conventional energy sources are naturally present and have been in use for years. The use of conventional sources is done for heating, lighting, cooking, running machinery, and provision of electricity. The examples for which include firewood, fossil fuels, and others. In addition, firewood has been extensively used for cooking purposes in remote regions of India. The fossil fuels are plants, and animal remains, which have been buried from millions of years ago within the earth. These remains are decomposed and formed primary energy sources like coal, petroleum, natural gas, etc.

Example: Thermal, Hydro, Gas, Diesel, etc

- Non- Conventional energy sources are the best alternatives to conventional sources while also non- polluting. In 1973, the oil crisis encouraged a focus on non – conventional sources, which has increased in recent times due to high environmental pollution.
- Non-conventional sources could be obtained from sun, wind, hot springs, and others that support heat and power generation. They are non-polluting and present in abundance within the earth's atmosphere.

3. Write Short note on

(a) Porcelain Insulator

- Porcelain is most commonly used material for over head insulator in present days. The porcelain is aluminium silicate.
- The aluminium silicate is mixed with plastic kaolin, feldspar and quartz to obtain final hard and glazed **porcelain insulator** material.
- The surface of the insulator should be glazed enough so that water should not be traced on it.
- It must also be free from any impurity and air bubble inside the material which may affect the insulator properties.

(b) Glass Insulator

- Now days glass insulator has become popular in transmission and distribution system. Annealed tough glass is used for insulating purpose. Glass insulator has numbers of advantages over conventional porcelain insulator. It has very high dielectric strength compared to porcelain.
- Its resistivity is also very high.
- It has low coefficient of thermal expansion.
- It has higher tensile strength compared to porcelain insulator.
- Glass has very long service life as because mechanical and electrical properties of glass do not be affected by ageing.
- After all, glass is cheaper than porcelain.

(c) Suspension type Insulator

- For high voltages (>33 kV), it is a usual practice to use suspension type insulators consist of a number of porcelain discs connected in series by metal links in the form of a string.
- The conductor is suspended at the bottom end of this string while the other end of the string is secured to the cross-arm of the tower.
- Each unit or disc is designed for low voltage, say 11 kV.
- The number of discs in series would obviously depend upon the working voltage.
- For instance, if the working voltage is 66 kV, then six discs in series will be provided on the string.

THEORY 1 st - IN-SEM EXAMINATION			
SESSION: 2022-23(SUMMER SEMESTER)			
B.Voc.	Semester	3 rd	
Course name	Electrical Machines-I		
Course code	ELE 1306		
Date			
Name of the Student		Reg. No.	

INSTRUCTIONS
<ul style="list-style-type: none"> • Maximum Marks: 20 • Duration of Examination: 01 Hour • Attempt all questions. • Scientific calculator is allowed.

1. Section A (05 objective type questions, each question carries 01 mark)	05×1 = 05
<ol style="list-style-type: none"> Which of the following part is used in construction of DC machine but not in AC machine? <ol style="list-style-type: none"> Armature Winding Field winding Commutator Shaft Function of yoke is to provide the return path for magnetic flux. <ol style="list-style-type: none"> True false What are the materials used for brushes in dc machines? <ol style="list-style-type: none"> Iron Carbon Aluminum Steel Which of the following does not change in a transformer? <ol style="list-style-type: none"> Voltage Current Frequency All of the above Where is field winding mounted in a DC machine? <ol style="list-style-type: none"> Stator Rotor Absent Anywhere on stator or rotor 	
2. Section B (03 short answer type questions, each question carries 02 marks)	03×02 = 06
<ol style="list-style-type: none"> What is a transformer? What is the difference between electric generator and electric motor? What is meant by synchronous speed? 	
3. Section C (03 long type questions, each question carries 03 marks)	03×03 = 09
<ol style="list-style-type: none"> Explain the two types of rotor constructors employed in an induction motor with schematic diagram. Why are electric motors and generators so common? Draw a neat and clean cross-sectional view of DC machine diagram and explain the construction features of DC machine. 	



THEORY 1 st - IN-SEM EXAMINATION		
SESSION: 2022-23(SUMMER SEMESTER)		
B.Voc	Semester	3 rd
Course name / Module	Electrical Machines-I	
Course code	ELE 1306	

1. Section A (05 objective type questions, each question carries 01 mark)	05×1 = 05
--	------------------

1. Which of the following part is used in construction of DC machine but not in AC machine?

a) Armature Winding	b) Field winding
c) Commutator	d) Shaft
2. Function of yoke is to provide the return path for magnetic flux.

a) True	b) false
---------	----------
3. What are the materials used for brushes in dc machines?

a) Iron	b) Carbon
c) Aluminum	d) Steel
4. Which of the following does not change in a transformer?

(a) Voltage	(b) Current
(c) Frequency	(d) All of the above
5. Where is field winding mounted in a DC machine?

a) Stator	b) Rotor
c) Absent	d) Anywhere on stator or rotor

6. Section B (03 short answer type questions, each question carries 02 marks)	03×02 = 06
--	-------------------

1. What is a transformer?

Ans. The transformer is an electrical device that is closely related to electrical machines. It converts ac electrical energy at one voltage level to ac electrical energy at another voltage level. Since transformers operate on the same principles as generators and motors, depending on the action of a magnetic field to accomplish the change in voltage level, they are usually studied together with generators and motors. It is this device that has made the electric system almost universally AC.

2. What is the difference between electric generator and electric motor?

Ans. An efficient and convenient way to generate electric power is by conversion of mechanical power into electrical form in a rotating device called a generator.

An efficient and convenient way to generate mechanical power is by conversion of electric power into mechanical form in a rotating device called a motor

3. What is meant by synchronous speed?

Ans. $n = 120 f/P$

where f = frequency in Hz

n = rotor speed in rpm

P = number of field poles

For a given number of poles, there is a fixed correspondence between the rotor speed and the stator frequency; the rotor speed is therefore called the *synchronous speed*.

7. Section C (03 long type questions, each question carries 03 marks)	03×03 = 09
--	-------------------

1. Explain the two types of rotor constructors employed in an induction motor with schematic diagram.

Ans. Two types of rotor constructions are employed which distinguish the type of induction motor.

1. **Squirrel-cage rotor** Here the rotor has copper (or aluminium) bars embedded in slots which are short circuited at each end as shown in Figure. It is a rugged economical construction but develops low starting torque.

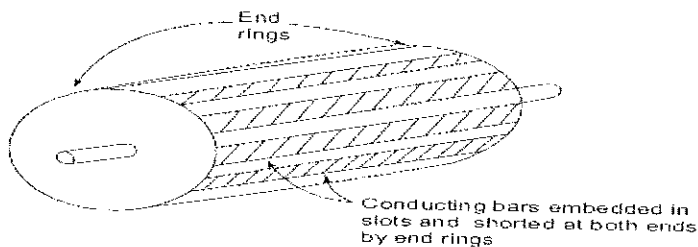

Figure: A squirrel-cage rotor (schematic diagram)

2. **Slip-ring (or wound-rotor) rotor** The rotor has a proper 3-phase winding with three leads brought out through slip-rings and brushes as shown in Figure. These leads are normally short-circuited when the motor is running. Resistances are introduced in the rotor circuit via the slip-rings at the time of starting to improve the starting torque.

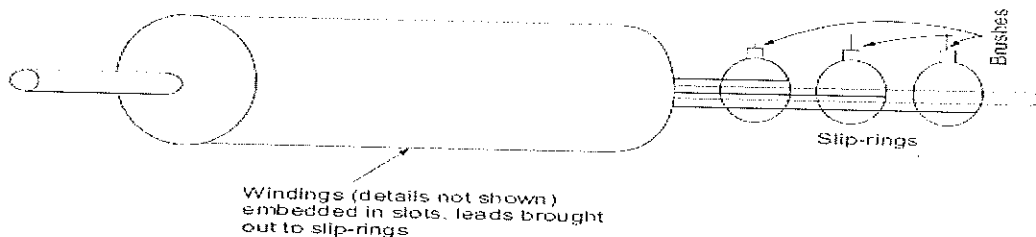

Figure: A wound rotor (schematic diagram)

2. Why are electric motors and generators so common?

Ans. The answer is very simple: Electric power is a clean and efficient energy source that is easy to transmit over long distances, and easy to control. An electric motor does not require constant ventilation and fuel the way that an internal-combustion engine does, so the motor is very well suited for use in environments where the pollutants associated with combustion are not desirable. Instead, heat or mechanical energy can be converted to electrical form at a distant location, the energy can be transmitted over long distances to the place where it is to be used, and it can be used cleanly in any home, office, or factory. Transformers aid this process by reducing the energy loss between the point of electric power generation and the point of its use.

3. Draw a neat and clean cross-sectional view of DC machine diagram and explain the construction features of DC machine.

Ans. In a *dc machine* the field poles are on the stator while the rotor is the armature as shown in the cross-sectional view of Figure. The field poles are symmetrical and are even in number, alternately north and south. As the armature rotates, alternating emf and current induced in the armature winding are rectified to dc form by a rotating mechanical switch called the *commutator*, which is tapped by means of stationary carbon *brushes*. The commutator is cylindrical in shape and comprises several wedge-shaped copper segments bound together while they are insulated from each other. The armature is made of laminated steel with slots cut out on the periphery to accommodate the insulated armature winding. The ends of each armature coil are connected to the commutator segments to form a closed winding. The armature when carrying current produces stationary poles (same as number of field poles) which interact with the field poles to produce the electromagnetic torque.

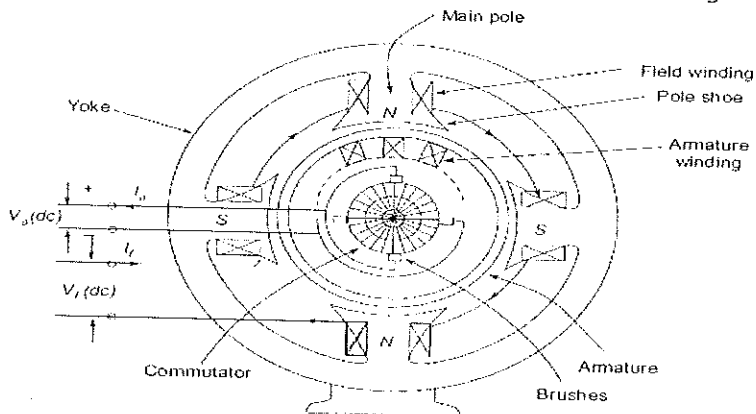

Figure: Cross-sectional view of dc machine

THEORY 1 st - IN-SEM EXAMINATION		
SESSION: 2022-23(SUMMER SEMESTER)		
B.Voc	Semester	3 rd
Course name	Electrical Circuit & Drawing	
Course code	ELE1307	
Date		
Name of the Student		Reg. No.

INSTRUCTIONS

- Maximum Marks: **20**
- Duration of Examination: **01 Hour**
- Attempt all questions.

1. Section A (05 objective type questions, each question carries 01 mark)

05 × 1 = 05

- The ideal sources are practically _____ sources in the electrical circuits?
 - Possible
 - Imaginary
 - Both (a) and (b)
 - None of these
- KCL stands for _____ in the electrical circuits.
 - Kirchoff's Current Law
 - Kirchoff's Capacity Law
 - Kinetic Current Law
 - None of these
- Which kirchoff's law is used in the Mesh analysis for electrical circuits?
 - KCL
 - KVL
 - Both (a) and (b)
 - None of these
- The _____ is the example of the active components in the electrical circuits.
 - Diode
 - Resistor
 - Inductor
 - Capacitor
- What is the voltage of reference node of the electrical circuit while using nodal analysis.
 - V=220 Vols
 - V=infinite Volts
 - V=0 Volts
 - None of these

2. Section B (03 short answer type questions, each question carries 02 marks)

03 × 02 = 06

- What is the passive components?
- Explain the electrical circuit.
- Describe the node and loop terms related to electrical circuits.

3. Section C (03 long type questions, each question carries 03 marks)

03 × 03 = 09

- Differentiate the ideal and practical voltage sources in detail.
- Explain the mesh analysis and nodal analysis.
- Resistors of $R_1 = 10\Omega$, $R_2 = 4\Omega$ and $R_3 = 8\Omega$ are connected up to two batteries (of negligible resistance) as shown. Find the current through each resistor.

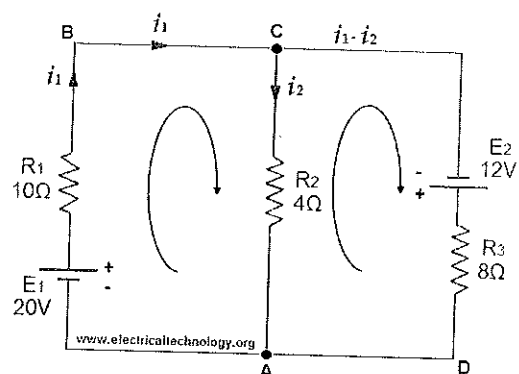

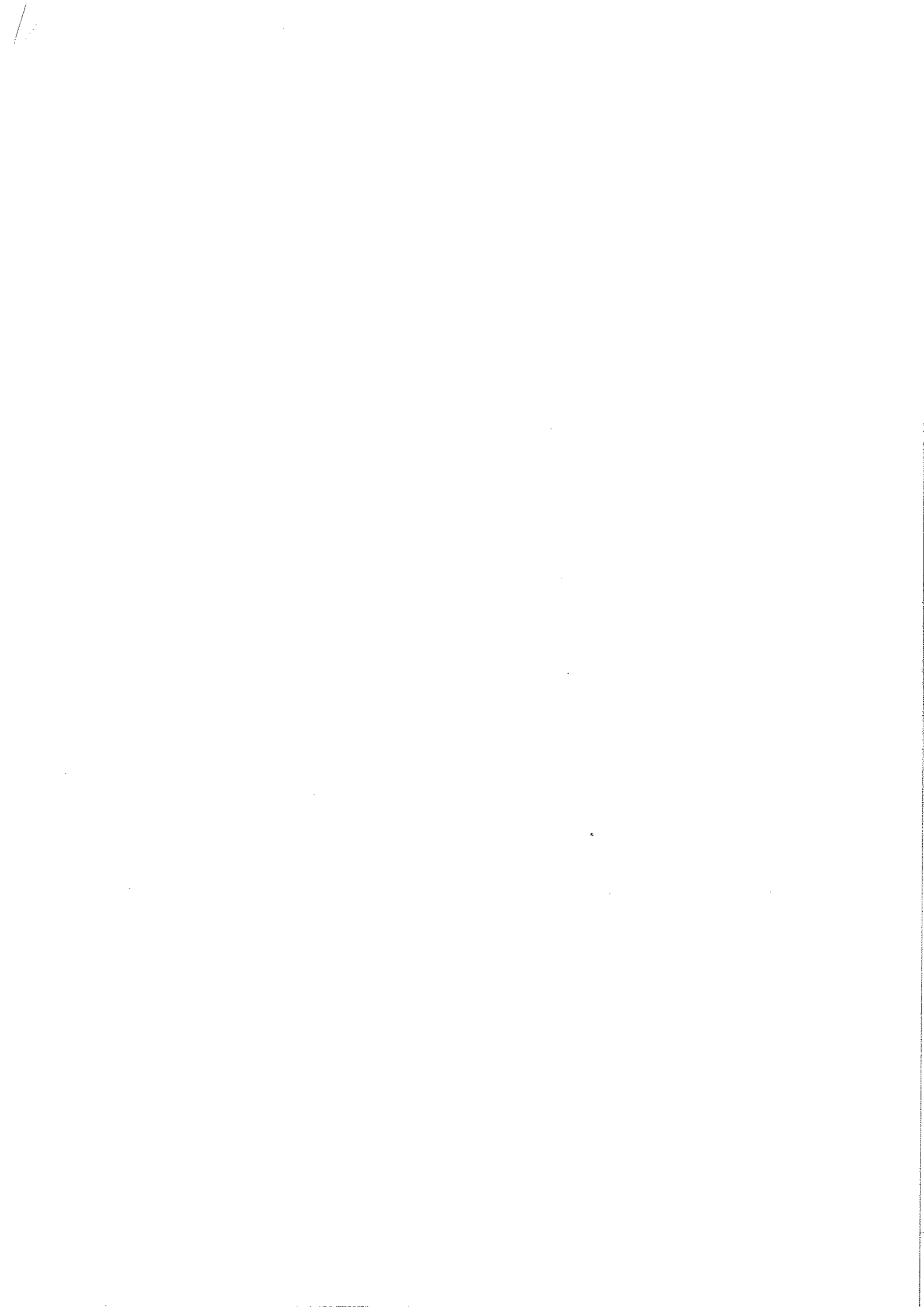

THEORY 1 st - IN-SEM EXAMINATION			
SESSION: 2022-23(SUMMER SEMESTER)			
B.Voc/M.Voc		Semester	3 rd
Course name / Module	Electrical Circuit & Drawing		
Course code	ELE1307		
Date			
Name of the Student		Reg. No.	

1. Section A (05 objective type questions, each question carries 01 mark)	05×1 = 05
--	------------------

1. (b) Imaginary
2. (a) Kirchoff's Current Law
3. (b) KVL
4. (a) Diode
5. (c) V=0 Volts

2. Section B (03 short answer type questions, each question carries 02 marks)	03×02 = 06
--	-------------------

1. Passive Components

Those devices or components which do not require an external source to operate in a circuit are called Passive Components.

For Example: Resistor, Capacitor, Inductor etc...

Explanation: Passive Components (such as resistors, capacitors, inductors etc.) do not require an external source to their operation.

Like a Diode, Resistor does not require 0.3V or 0.7 V. i.e., when we connect a resistor to the supply voltage, it starts work and responds instantly in the circuit without using additional and conditional specific voltage like in case of diodes etc. Same is the case for inductors and capacitors etc.

2. Electrical Circuits

An electric circuit is a closed loop network which provides a return path for the flow of current. Or a closed conducting path in which current can flow is called a circuit. An electric circuit is also known as electrical network or electrical circuit.

An electrical circuit is the combination of different active and passive components such as resistors, capacitors, inductors, diodes, transistors etc. which form an electrical network. In a closed-loop circuit, the electric current flows from the source (such as battery) in the conducting material (e.g. wires and cables) to the load (i.e. light bulb) and hence returns back to the source.

3. Terms Related to Electrical circuits:

Node

A point or junction where two or more circuit's elements (resistor, capacitor, inductor etc) meet is called Node.

Loop

A closed path in a circuit where more than two meshes can occur is called loop i.e. there may be many meshes in a loop, but a mesh does not contain one loop.

3. Section C (03 long type questions, each question carries 03 marks)	03×03 = 09
--	-------------------

1. Ideal Voltage Source:

The ideal voltage source provides a constant voltage at its terminal regardless of the current drawn out of it. Ideal voltage sources are only theoretical and can't be developed in a laboratory. An ideal voltage source doesn't have internal resistance and no voltage drop occurs due to the resistance, so the terminal voltage remains constant.

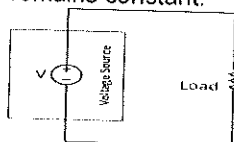

Ideal Voltage Source

Practical Voltage Source:

Practical voltage sources are real and used in daily life. A practical voltage source has internal resistance that causes a drop in terminal voltage due to the current flow.

BHARTIYA SKILL DEVELOPMENT UNIVERSITY JAIPUR

Plot No. 005/001-002 | Domestic Tariff Area | Mahindra World | City Jaipur | Rajasthan

www.rti-bsdu.in | +91 91166 11131

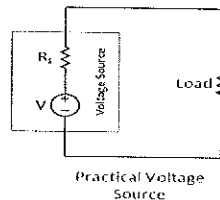

2. Mesh Analysis:

Mesh analysis (or the mesh current method) is a method that is used to solve planar circuits for the currents (and indirectly the voltages) at any place in the circuit. Planar circuits are circuits that can be drawn on a plane surface with no wires crossing each other.

Mesh analysis works by arbitrarily assigning mesh currents in the essential meshes. An essential mesh is a loop in the circuit that does not contain any other loop.

Steps to Determine Mesh Currents:

Assign mesh currents i_1, i_2, \dots, i_n to the n meshes. Current direction need to be same in all meshes either clockwise or anticlockwise.

Apply KVL to each of the n meshes. Use Ohm's law to express the voltages in terms of the mesh currents.

Solve the resulting n simultaneous equations to get the mesh currents

Nodal Analysis:

In electric circuits analysis, nodal analysis, node-voltage analysis, or the branch current method is a method of determining the voltage (potential difference) between "nodes" (points where elements or branches connect) in an electrical circuit in terms of the branch currents.

Nodal analysis is possible when all the circuit elements branch constitutive relations have an admittance representation.

Kirchhoff's current law is used to develop the method referred to as nodal analysis

STEPS FOR NODAL ANALYSIS: -

- Note all connected wire segments in the circuit. These are the nodes of nodal analysis.
- Select one node as the ground reference. The choice does not affect the result and is just a matter of convention. Choosing the node with most connections can simplify the analysis.
- Assign a variable for each node whose voltage is unknown. If the voltage is already known, it is not necessary to assign a variable.
- For each unknown voltage, form an equation based on Kirchhoff's current law. Basically, add together all currents leaving from the node and mark the sum equal to zero.
- If there are voltage sources between two unknown voltages, join the two nodes as a super node. The currents of the two nodes are combined in a single equation, and a new equation for the voltages is formed.
- Solve the system of simultaneous equations for each unknown voltage.

3. Solution:

Assume currents to flow in directions indicated by arrows.

Apply KCL on Junctions C and A.

Therefore, current in mesh ABC = i_1

Current in Mesh CA = i_2

Then current in Mesh CDA = $i_1 - i_2$

Now, Apply KVL on Mesh ABC, 20V are acting in clockwise direction. Equating the sum of IR products, we get;

$$10i_1 + 4i_2 = 20 \quad \dots (1)$$

In mesh ACD, 12 volts are acting in clockwise direction, then:

$$8(i_1 - i_2) - 4i_2 = 12$$

$$8i_1 - 8i_2 - 4i_2 = 12$$

$$8i_1 - 12i_2 = 12 \quad \dots (2)$$

Multiplying equation (1) by 3;

$$30i_1 + 12i_2 = 60$$

Solving for i_1

$$30i_1 + 12i_2 = 60$$

$$8i_1 - 12i_2 = 12$$

$$38i_1 = 72$$

The above equation can be also simplified by Elimination or Cramer's Rule.

$i_1 = 72 \div 38 = 1.895$ Amperes = Current in 10 Ohms resistor

Substituting this value in (1), we get:

$$10(1.895) + 4i_2 = 20 \quad ; \quad 4i_2 = 20 - 18.95$$

$i_2 = 0.263$ Amperes = Current in 4 Ohms Resistors.

Now, $i_1 - i_2 = 1.895 - 0.263 = 1.632$ Amperes