



School of Electrical Skills
Session: 2020-21 (Summer Semester)
B. Voc. Program, 5th Semester,
End-Sem. Examination

Course Code: ELE1501

Time: 2 Hours

Course Name: Fundamentals of Power Electronics

Max. Marks: 50

Instruction: Answer all questions from section A, each question carries one mark. Answer all questions from section B, each question carries four marks. Answer all questions from section C, each question carries six marks. Scientific calculator is allowed.

Section – A

10X01 = 10 Marks

1. Full form of the UJT is: -
 - (a) Uni-Junction Transistor
 - (b) Unbiased-Junction Transistor
 - (c) Unsafe-Junction Transistor
 - (d) None of these
2. Full form of the SCR is: -
 - (a) Serial Controlled Rectifier
 - (b) Silicon Controlled Rectifier
 - (c) Serial Controlled Relay
 - (d) None of these
3. Boost converter is used to _____ DC supply: -
 - (a) Step up
 - (b) Step Down
 - (c) Both (a) & (b)
 - (d) None of these
4. The efficiency of full wave rectifier is: -
 - (a) 25%
 - (b) 81%
 - (c) 51%
 - (d) 95%
5. PN junction behave as a short circuit in: -
 - (a) Reverse biased
 - (b) Forward biased
 - (b) Unbiased
 - (d) None of these
6. The transistor operates as an amplifier in _____ region: -
 - (a) Cut-off
 - (b) Saturation
 - (c) Active
 - (d) None of these
7. The angle ($\pi - \alpha = \beta$) during the thyristor conducts is called the _____.
 - (a) Firing angle
 - (b) conduction angle
 - (c) commutation angle
 - (d) None of these
8. The number of thyristors used in single phase full wave center tap controlled rectifier.
 - (a) one
 - (b) two
 - (c) four
 - (d) none of these
9. Gate turn-Off Thyristor is a _____ terminal Device.: -
 - (a) Two
 - (b) Three
 - (c) Four
 - (d) None of these



10. _____ configuration is commonly known as a "Emitter Follower" circuit.
- (a) Common base (b) Common emitter
(c) Common Collector (d) None of these

Section – B

04X04 = 16 Marks

1. What are the advantages and disadvantages of power electronics converter?
2. Describe the following components with their symbols: -
(A) DIAC (B) TRIAC
3. List the various applications of SCR.
4. Write short note on phase controlled rectifier.

Section – C

04X06 = 24 Marks

1. Explain the single phase full wave uncontrolled bridge rectifier with the help of diagram.
2. Explain the Boost converter and its operation.
3. Write in brief about the IGBT with its symbol & applications.
4. Explain the single phase full bridge inverter with the help of diagram.



Answer Key ELE 1501 (Set – A)
BHARTIYA SKILL DEVELOPMENT UNIVERSITY
School of Electrical Skills

Session: 2020-21 (Summer Semester)

B. Voc. Program, 5th Semester,

End-Sem. Examination

Course Code: ELE1501

Time: 2 Hours

Course Name: Fundamentals of Power Electronics

Max. Marks: 50

Section – A

10X01 = 10 Marks

1. Full form of the UJT is: -
(a) Uni-Junction Transistor
2. Full form of the SCR is: -
(b) Silicon Controlled Rectifier
3. Boost converter is used to _____ DC supply: -
(a) Step up
4. The efficiency of full wave rectifier is: -
(b) 81%
5. PN junction behave as a short circuit in: -
(b) Forward biased
6. The transistor operates as an amplifier in _____ region: -
(c) Active
7. The angle ($\pi - \alpha = \beta$) during the thyristor conducts is called the _____.
(b) conduction angle
8. The no. of thyristor used in single phase full wave center tap controlled rectifier.
(b) two
9. Gate turn-Off Thyristor is a _____ terminal Device.: -
(b) Three
10. _____ configuration is commonly known as a "Emitter Follower" circuit.
(c) Common Collector

Section – B

04X04 = 16 Marks

1. What are the advantages and disadvantages of power electronics converter?

Ans. Advantages of Power Electronic Converters

- High efficiency
- High reliability
- Long life and less maintenance
- Fast dynamic response
- Small size and less weight & cost.



BHARTIYA SKILL DEVELOPMENT UNIVERSITY

Disadvantages of Power Electronic Converters

- Harmonics generating tendency.
- Power regeneration is difficult
- Low overload capacity.
- AC – DC & AC – AC converters operate at low i/p power factors.

2. Describe the following components with their symbols: -

(A) DIAC

(B) TRIAC

Ans. **(A) DIAC: Diode on AC**

The name DIAC comes from the words Diode AC switch. The DIAC is an electronics component that is widely used to assist even triggering.

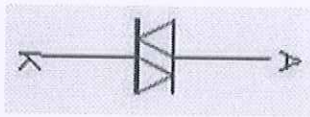

(B) TRIAC: Triode for Alternating Current

It is a five layer device. It has three terminals namely Terminal-1, Terminal-2 and gate.

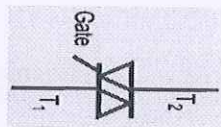

3. List the various applications of SCR.

Ans. **Applications of SCR**

- The silicon controlled rectifier (SCR) is used in AC voltage stabilizers.
- The silicon controlled rectifier (SCR) is used as switch.
- It is used in choppers.
- The silicon controlled rectifier (SCR) is used in inverters.
- The silicon controlled rectifier (SCR) is used for power control.
- It is used for DC circuit breaker.
- Silicon control rectifier (SCR) is used in battery charger.
- It is used to Adjust light dimmer.
- It is used to control motors speed.
- The SCR is used in pulse circuit.
- It is used for AC power control with relay.

4. Write short note on phase controlled rectifier.

Ans.

Phase Controlled Rectifiers



BHARTIYA SKILL DEVELOPMENT UNIVERSITY

These are similar to the uncontrolled rectifiers but the only difference is that the uncontrolled diodes are replaced by controlled thyristor family of devices such as SCRs.

- These are also called as phase controlled rectifiers. Unlike diodes, thyristor can be controlled by triggering them at desired instants in order to vary the output voltage.

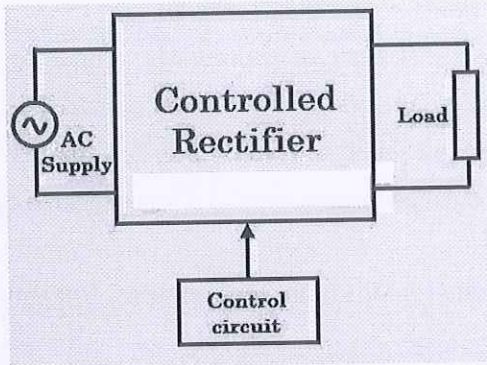

- The block diagram of a controlled rectifier is shown in the above figure that transfers the DC power to the load in a control manner by varying triggering angle of thyristor (by the control circuit) using different technologies such as a microprocessor or microcontroller based techniques.

Section – C

04X06 = 24 Marks

1. Explain the single phase full wave bridge rectifier with the help of diagram.

Ans.

Single phase full-wave bridge rectifier

In bridge rectifier four diodes are used. These are connected as shown in the circuit diagram. The four diodes are connected in the form of a bridge to the transformer and the load as shown.

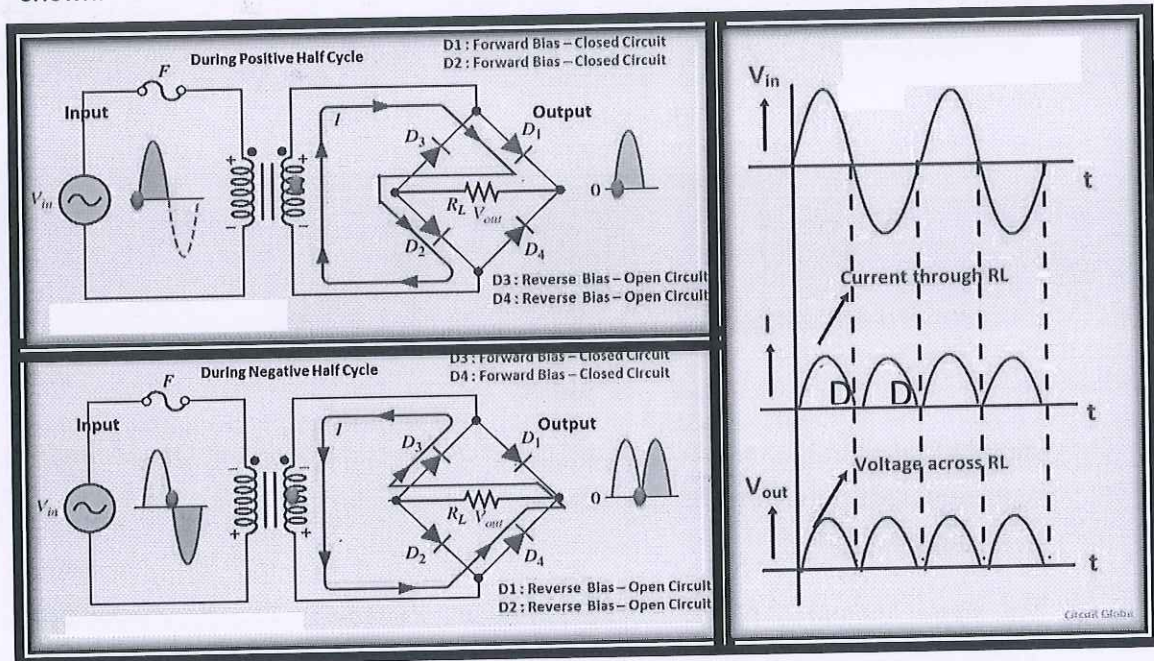

Working of Bridge Rectifier:

- The circuit diagram of bridge rectifier is given in previous slide. The secondary winding of the transformer is connected to the two diametrically opposite points of the bridge. Assume that a load R_{Load} is connected at the output.



BHARTIYA SKILL DEVELOPMENT UNIVERSITY

During first half cycle of the AC input, the upper portion of the transformer secondary winding is positive with respect to the lower portion. Thus during the first half cycle diodes D_1 and D_2 are forward biased. Current flows through D_1 enter into the load R_L . It returns back flowing through D_2 . During this half input cycle, the diodes D_3 and D_4 are reverse biased. Hence there is no current flow through the D_3 and D_4 .

- During the next cycle lower portion of the transformer is positive with respect to the upper portion. Hence during this cycle diodes D_3 and D_4 are forward biased. Current flows through the D_3 and flows back through the D_4 . The diodes D_1 and D_2 are reverse biased. So there is no current flow through the D_1 and D_2 . Thus negative cycle is rectified and it appears across the load.
- Peak Inverse Voltage (PIV) of a bridge rectifier = Maximum of Secondary Voltage

2. Explain the Boost converter and its operation.

Ans.

Boost converter and its Operation

- In this chopper, the output voltage is always greater than input voltage. The configuration of a boost converter is shown in figure below.
- Fig illustrates the circuit action during the initial high period of the high frequency square wave applied to the MOSFET gate at start up. During this time MOSFET conducts, placing a short circuit from the right hand side of L_1 to the negative input supply terminal. Therefore a current flows between the positive and negative supply terminals through L_1 , which stores energy in its magnetic field. There is virtually no

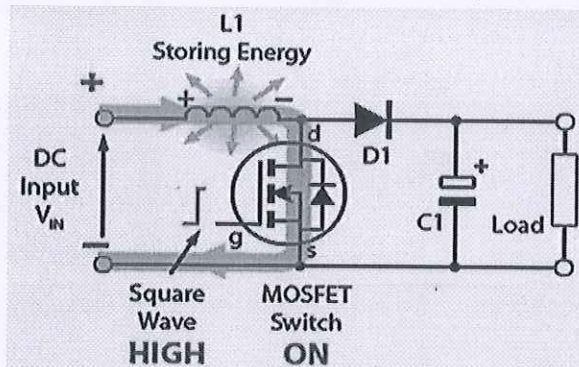

current flowing in the remaining of the circuit as the combination of D_1 , C_1 and the load represent a much higher impedance than the path directly through the heavily conducting MOSFET.

- Fig. shows the current path during the low period of the switching square wave cycle. As the MOSFET is rapidly turned off the sudden drop in current causes L_1 to produce a back e.m.f. in the opposite polarity to the voltage across L_1 during the on period, to keep current flowing. This results in two voltages, the supply voltage V_{IN} and the back e.m.f. (V_L) across L_1 in series with each other.



BHARTIYA SKILL DEVELOPMENT UNIVERSITY

This higher voltage ($V_{IN} + V_L$), now that there is no current path through the MOSFET, forward biases D1. The resulting current through D1 charges up C1 to $V_{IN} + V_L$ minus the small forward voltage drop across D1, and also supplies the load.

- Fig. shows the circuit action during MOSFET on periods after the initial start up. Each time the MOSFET conducts, the cathode of D1 is more positive than its anode, due to the charge on C1. D1 is therefore turned off so the output of the circuit is isolated from the input, however the load continues to be supplied with $V_{IN} + V_L$ from the charge on C1. Although the charge C1 drains away through the load during this period, C1 is recharged each time the MOSFET switches off, so maintaining an almost steady output voltage across the load.
- The theoretical DC output voltage is determined by the input voltage (V_{IN}) divided by 1 minus the duty cycle (D) of the switching waveform.

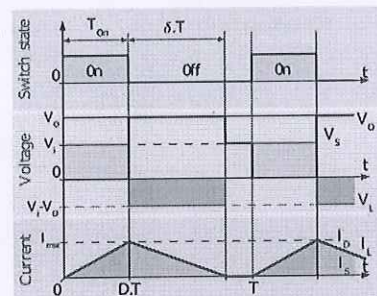
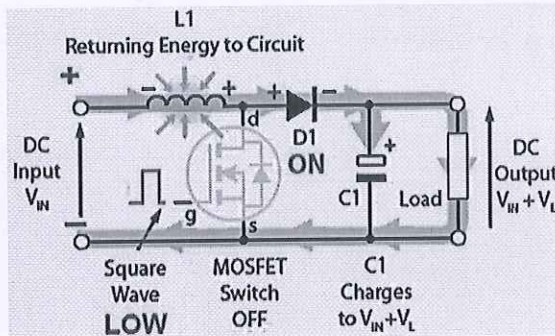
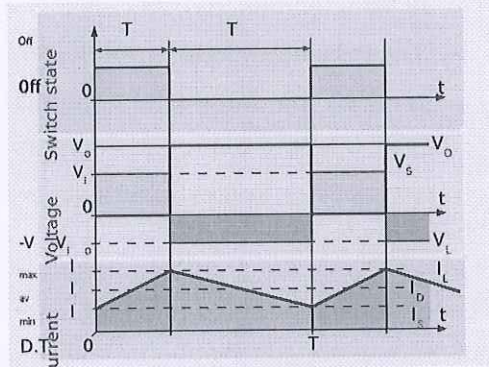
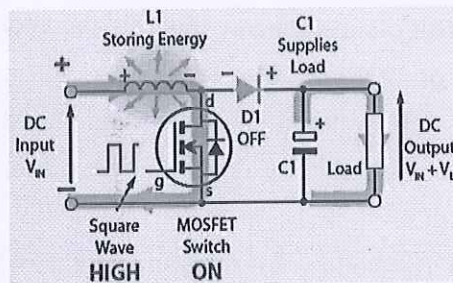

3. Write in brief about the IGBT with its symbol & applications.

Ans.

Insulated Gate Bipolar Transistor(IGBT)

- The IGBT is a power switching transistor which combines the advantages of MOSFETs and BJTs for use in power supply and motor control circuits.
- The Insulated Gate Bipolar Transistor also called an IGBT for short, is something of a cross between a conventional Bipolar Junction Transistor, (BJT) and a Field Effect Transistor, (MOSFET) making it ideal as a semiconductor switching device.



BHARTIYA SKILL DEVELOPMENT UNIVERSITY

The Insulated Gate Bipolar Transistor, (IGBT) combines the insulated gate (hence the first part of its name) technology of the MOSFET with the output performance characteristics of a conventional bipolar transistor, (hence the second part of its name).

- The result of this hybrid combination is that the “IGBT Transistor” has the output switching and conduction characteristics of a bipolar transistor but is voltage-controlled like a MOSFET.
- The advantage gained by the insulated gate bipolar transistor device over a BJT or MOSFET is that it offers greater power gain than the standard bipolar type transistor combined with the higher voltage operation and lower input losses of the MOSFET. In effect it is an FET integrated with a bipolar transistor in a form of Darlington type configuration as shown.
- As a result, the terminals are labelled as: **Collector**, **Emitter** and **Gate**. Two of its terminals (C-E) are associated with the conductance path which passes current, while its third terminal (G) controls the device.
- The **Insulated Gate Bipolar Transistor** can be used in small signal amplifier circuits in much the same way as the BJT or MOSFET type transistors. But as the IGBT combines the low conduction loss of a BJT with the high switching speed of a power MOSFET an optimal solid state switch exists which is ideal for use in power electronics applications
- the IGBT has a much lower “on-state” resistance, R_{ON} than an equivalent MOSFET.

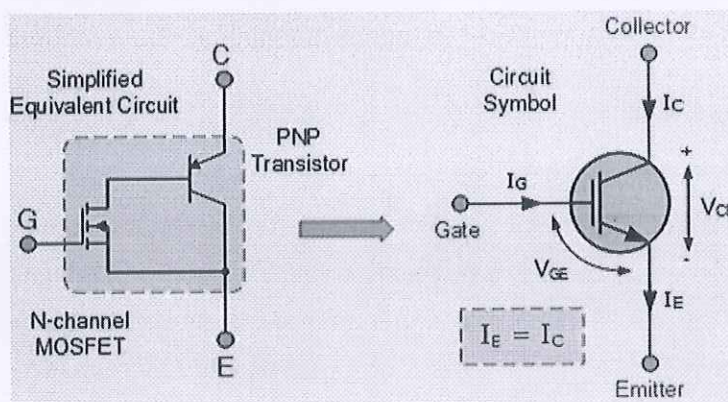

Applications of IGBT

Some of the important applications of IGBT are

- Switching mode power supplies (SMPS).
- UPS systems (IGBT based inverters).
- AC motor controllers.
- Choppers.
- Inverters.



4. Explain the full phase bridge inverter with the help of diagram.

Ans.

Single Phase Full Bridge Inverter

The output voltage V_o in single phase full bridge inverter can be V_{dc} , $-V_{dc}$ or zero, depending on which switches are closed.

Switched Closed	Output Voltage V_o
T_1 and T_2	$+V_{dc}$
T_3 and T_4	$-V_{dc}$
T_1 and T_3	0
T_2 and T_4	0

T_1 and T_2 Closed

T_3 and T_4 Closed

T_1 and T_3 Closed

T_2 and T_4 Closed

BHARTIYA SKILL DEVELOPMENT UNIVERSITY

T_1 and T_2 should not be closed at the same time, nor should T_3 and T_4 . Otherwise, a short circuit would exist across the dc source

The switches connect the load to $+V_{dc}$ when T_1 and T_2 are closed or to $-V_{dc}$ when T_3 and T_4 are closed. The periodic switching of the load voltage between $+V_{dc}$ and $-V_{dc}$ produces a square wave voltage across the load. Although this alternating output is nonsinusoidal, it may be an adequate ac waveform for some applications.

- The current waveform in the load depends on the load components.
- For the resistive load, the current waveform matches the shape of the output voltage.

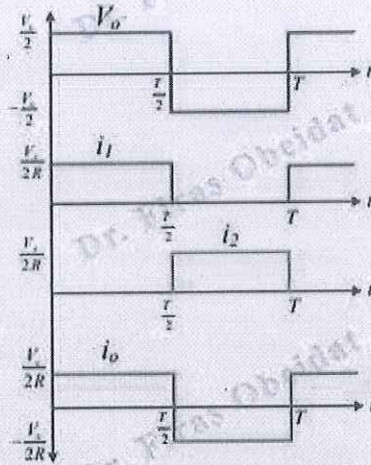
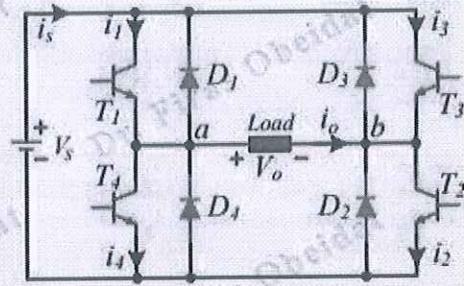

The waveforms when resistive load



School of Electrical Skills
Session: 2020-21 (Summer Semester)
B. Voc. Program, 5th Semester,
End-Sem. Examination

Course Code: ELE1501**Time: 2 Hours****Course Name: Fundamentals of Power Electronics****Max. Marks: 50**

Instruction: Answer all questions from section A, each question carries one mark. Answer all questions from section B, each question carries four marks. Answer all questions from section C, each question carries six marks. Scientific calculator is allowed.

Section – A

10X01 = 10 Marks

1. Full form of the BJT is: -
(a) Bipolar Junction Transformer (b) Bipolar Jump Transistor
(c) Bipolar Junction Transistor (d) None of these
2. Full form of the GTO is: -
(a) Gate Turnoff Transistor (b) Gate Turn-on Transistor
(c) Gate Turnoff Thyristor (d) None of these
3. Buck converter is used to _____ DC supply: -
(a) Step up (b) Step Down
(c) Both (a) & (b) (d) None of these
4. _____ converts DC to AC of desired frequency and voltage: -
(a) Rectifier (b) Inverter
(c) Chopper (d) Cycloconverter
5. Silicon Controlled Rectifier is a _____ device: -
(a) Unidirectional (b) Bidirectional
(c) Uncontrollable (d) None of these
6. The _____ MOSFET requires the Gate-Source voltage to switch the device "OFF".
(a) Depletion type (b) Enhancement type
(c) Both A and B (d) None of these
7. The angle (α) after which the thyristor start conducting is called the _____.
(a) Firing angle (b) conduction angle
(c) commutation angle (d) None of these
8. The number of thyristors used in single phase full wave controlled bridge rectifier.
(a) one (b) two
(c) four (d) none of these
9. PN junction behave as a short circuit in: -
(a) Reverse biased (b) Forward biased
(c) Unbiased (d) None of these



10. _____ configuration is commonly known as a "Emitter Follower" circuit.
- (a) Common base (b) Common emitter
(c) Common Collector (d) None of these

Section – B

04X04 = 16 Marks

1. What are the characteristics of an ideal switch?
2. Describe the following components with their symbols: -
(A) SCR (B) Power Diode
3. Write the names of four possible triggering modes of operation of TRIAC.
4. Write short note on phase controlled rectifier.

Section – C

04X06 = 24 Marks

1. Explain the single phase full wave center tap rectifier with the help of diagram.
2. Explain the Buck-Boost converter and its operation.
3. Explain the different types of BJT configurations (CB, CE & CC).
4. Describe the single phase half bridge inverter with resistive load.



Ans. Key ELE 1501 (Set – B)
BHARTIYA SKILL DEVELOPMENT UNIVERSITY

School of Electrical Skills
Session: 2020-21 (Summer Semester)
B. Voc. Program, 5th Semester,
End-Sem. Examination

Course Code: ELE1501

Time: 2 Hours

Course Name: Fundamentals of Power Electronics

Max. Marks: 50

Section – A

10X01 = 10 Marks

1. Full form of the BJT is: -
(c) Bipolar Junction Transistor
2. Full form of the GTO is: -
(c) Gate Turnoff Thyristor
3. Buck converter is used to _____ DC supply: -
(b) Step Down
4. _____ converts DC to AC of desired frequency and voltage:-
(b) Inverter
5. Silicon Controlled Rectifier is a _____ device: -
(a) Unidirectional
6. The _____ MOSFET requires the Gate-Source voltage to switch the device “OFF”.
(a) Depletion type
7. The angle (α) after which the thyristor start conducting is called the _____.
(a) Firing angle
8. The no. of thyristor used in single phase full wave controlled bridge rectifier.
(c) four
9. PN junction behave as a short circuit in: -
(b) Forward biased
10. _____ configuration is commonly known as a “Emitter Follower” circuit.
(c) Common Collector

Section – B

04X04 = 16 Marks

1. What are the characteristics of an ideal switch?

Ans. Characteristics of Ideal Switch

- Turns On – Off in zero time.
- ON state, zero voltage drop, High current.
- OFF state, Zero current flow. Withstand high voltage.
- Zero power dissipation.
- Little power for controlling.
- High reliability.
- Small size and weight.
- No maintenance.

2. Describe the following components with their symbols: -

(A) SCR

(B) Power Diode

Ans. (A) SCR: Silicon Controlled Rectifier

It has three terminals namely Anode (A), cathode(K) and Gate(G). When the Anode terminal is positive with respect to cathode (K) terminal device is in forward blocking mode. Now if the voltage is applied to the gate terminal with respect to the cathode, the device will start to conduct. As the name indicates it is made up of silicon. It works as a rectifier. Its operation as a rectifier is controllable.

(B) Power Diode: It is a two terminal P-N junction device. The terminals are namely Anode and Cathode.

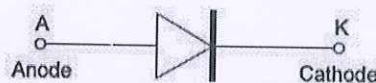
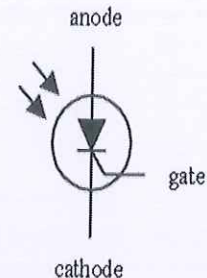

3. Write the names of four possible triggering modes of operation of TRIAC.

Ans. A triac has four possible triggering modes of operation as follows.

- I + Mode = MT₂ current positive (+ve), Gate current positive (+ve)
- I – Mode = MT₂ current positive (+ve), Gate current negative (-ve)
- III + Mode = MT₂ current negative (-ve), Gate current positive (+ve)
- III – Mode = MT₂ current negative (-ve), Gate current negative (-ve)

4. Write short note on phase controlled rectifier.

Phase Controlled Rectifiers

- These are similar to the uncontrolled rectifiers but the only difference is that the uncontrolled diodes are replaced by controlled thyristor family of devices such as SCRs.
- These are also called as phase controlled rectifiers. Unlike diodes, thyristor can be controlled by triggering them at desired instants in order to vary the output voltage.

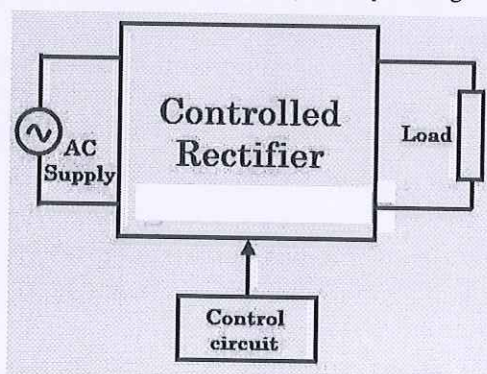

- The block diagram of a controlled rectifier is shown in the above figure that transfers the DC power to the load in a control manner by varying triggering angle of thyristor (by the control circuit) using different technologies such as a microprocessor or microcontroller based techniques.

Section – C

04X06 = 24 Marks

1. Explain the single phase full wave center tap

rectifier with the help of diagram.

Ans.

Single phase Center-tapped full-wave rectifier

- Center tap is the contact made at the middle of the winding of the transformer.
- In the center tapped full wave rectifier two diodes were used. These are connected to the center tapped secondary winding of the transformer. Above circuit diagram shows the center tapped full wave rectifier. It has two diodes.

The positive terminal of two diodes is connected to the two ends of the transformer. Center tap divides the total secondary voltage into equal parts.

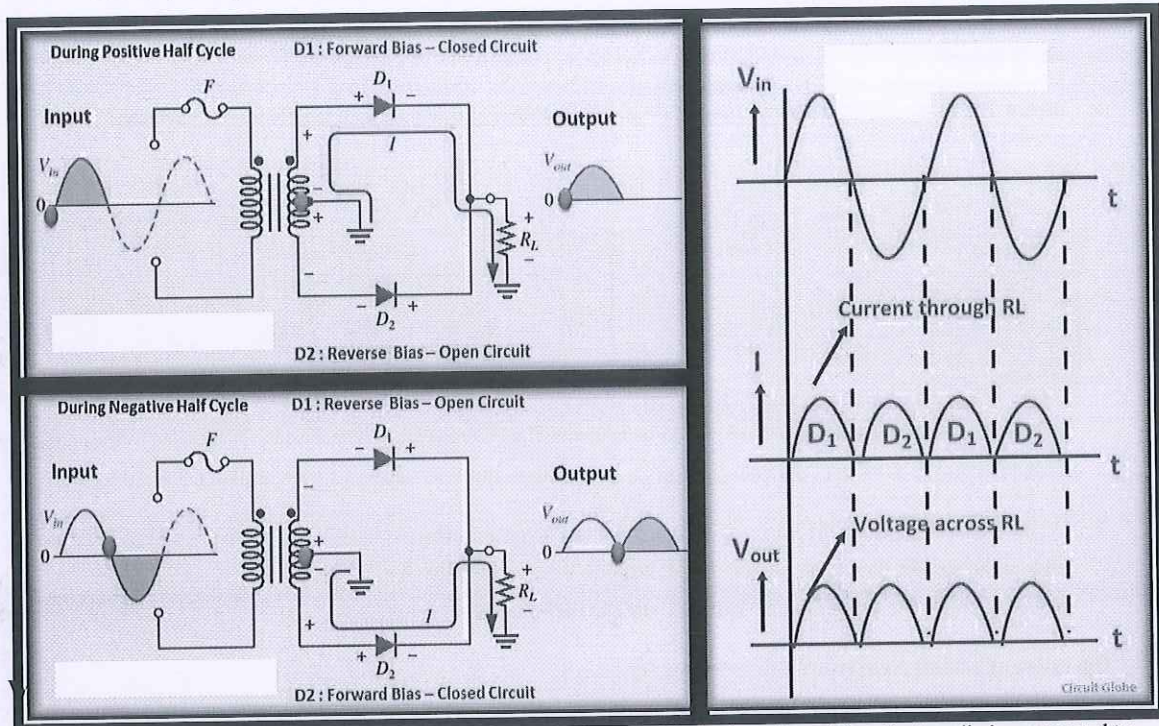

- The primary winding of the Center tap transformer is applied with the Ac voltage. Thus the two diodes connected to the secondary of the transformer conducts alternatively. For the positive half cycle of the input diode D1 is connected to the positive terminal and D2 is connected to the negative terminal. Thus diode D1 is in forward bias and the diode D2 is reverse biased. Only diode D1 starts conducting and thus current flows from diode and it appears across the load RL. So positive cycle of the input is appeared at the load.
- During the negative half cycle, the diode D2 is applied with the positive cycle. D2 starts conducting as it is in forward bias. The diode D1 is in reverse bias and this does not conduct. Thus current flows from diode D2 and hence negative cycle is also rectified, it appears at the load resistor RL.
- By comparing the current flow through load resistance in the positive and negative half cycles, it can be concluded that the direction of the current flow is same. Thus the frequency of rectified output voltage is two times the input frequency. The output that is rectified is not pure, it consists of a dc component and a lot of ac components.

2. Explain the Buck-Boost converter and its operation.

Ans. Buck-Boost Converters

Operation as a Buck Converter

- Below Fig. shows the circuit operating as a Buck Converter. In this mode Tr2 is turned off, and Tr1 is switched on and off by a high frequency square wave from the control unit. When the gate of Tr1 is high, current flows through L, charging its magnetic field, charging C and supplying the load. The Schottky diode D1 is turned off due to the positive voltage on its cathode.
- Below Fig shows the current flow during the buck operation of the circuit when the control unit switches Tr1 off. The

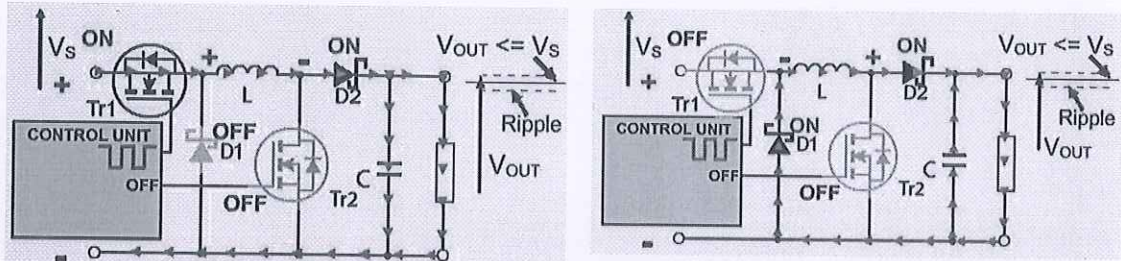

initial source of current is now the inductor L. Its magnetic field is collapsing, the back e.m.f. generated by the collapsing field reverses the polarity of the voltage across L, which turns on D1 and current flows through D2 and the load.

- As the current due to the discharge of L decreases, the charge accumulated in C during the on period of Tr1 now also adds to the current flowing through the load, keeping V_{OUT} reasonably constant during the off period. This helps keep the ripple amplitude to a minimum and V_{OUT} close to the value of V_s .

Operation as a Boost Converter

- In Boost Converter mode, Tr1 is turned on continually and the high frequency square wave applied to Tr2 gate. During the on periods when Tr2 is conducting, the input current flows through the inductor L and via Tr2, directly back to the supply negative terminal charging up the magnetic field around L. Whilst this is happening D2 cannot conduct as its anode is being held at ground potential by the heavily conducting Tr2. For the duration of the on period, the load is being supplied entirely by the charge on the capacitor C, built up on previous oscillator cycles. The gradual discharge of C during the on period (and its subsequent recharging) accounts for the amount of high frequency ripple on the output voltage, which is at a potential of approximately $V_s + V_L$.

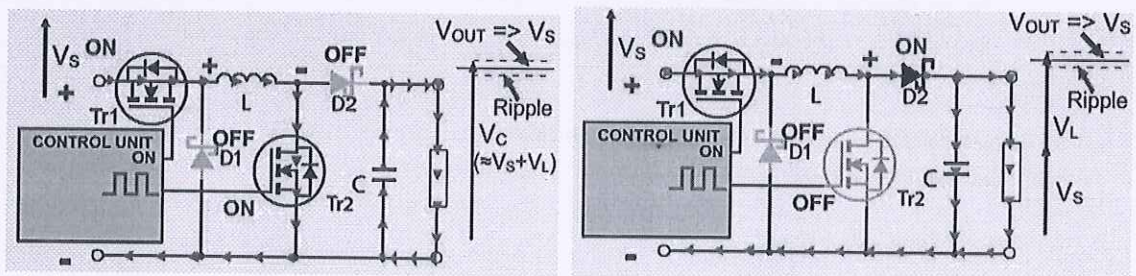

- At the start of the off period of Tr2, L is charged and C is partially dis charged. The inductor L now generates a back e.m.f. and its value that depends on the rate of change of current as Tr2 switches off and on the amount of inductance the coil possesses; therefore the back e.m.f. can be any voltage over a wide range, depending on the design of the circuit. Notice particularly that the polarity of the voltage across L has now reversed, and so adds to the input voltage V_s giving an output voltage that is at least equal to or greater than the input voltage. D2 is now forward biased and so the circuit current supplies the load current, and at the same time re-charges the capacitor to $V_s + V_L$ ready for the next on period of Tr2.

3. Explain the different types of BJT configurations (CB, CE & CC).



Ans.

Bipolar Transistor Configurations

1. The Common Base (CB) Configuration

As its name suggests, in the **Common Base** or grounded base configuration, the BASE connection is common to both the input signal AND the output signal. The input signal is applied between the transistors base and the emitter terminals, while the corresponding output signal is taken from between the base and the collector terminals as shown. The base terminal is grounded or can be connected to some fixed reference voltage point.

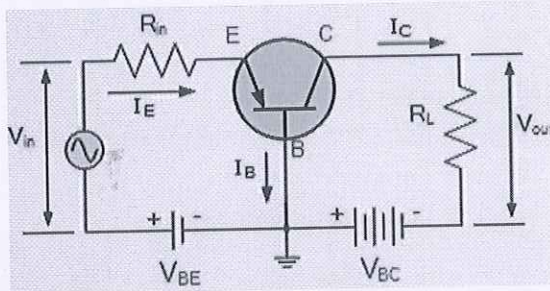

2. The Common Emitter (CE) Configuration

In the **Common Emitter** or grounded emitter configuration, the input signal is applied between the base and the emitter, while the output is taken from between the collector and the emitter as shown. This type of configuration is the most commonly used circuit for transistor based amplifiers and which represents the “normal” method of bipolar transistor connection.

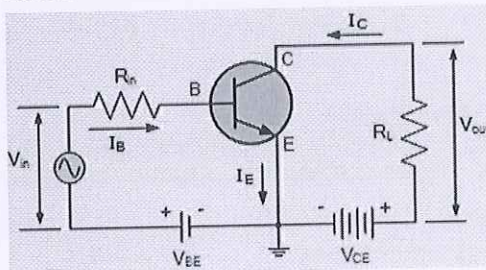

3. The Common Collector (CC) Configuration

In the **Common Collector** or grounded collector configuration, the collector is connected to ground through the supply, thus the collector terminal is common to both the input and the output. The input signal is connected directly to the base terminal, while the output signal is taken from across the emitter load resistor as shown. This type of configuration is commonly known as a **Voltage Follower** or **Emitter Follower** circuit.

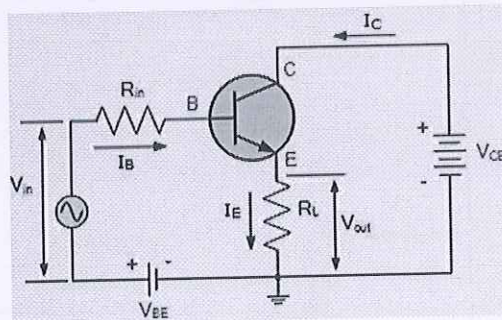

4. Describe the single phase half bridge inverter with resistive load.

Ans.

Single Phase Half Bridge Inverter – Resistive Load

Basic Operation

- Consists of 2 choppers, 3-wire DC source.
- Transistors switched ON and OFF alternately.
- Each provides opposite polarity of $V_s/2$ across the load.
- When T_1 is ON through the period $0 < t < T/2$, the output voltage equal to $V_s/2$.
- When T_2 is ON through the period $T/2 < t < T$, the output voltage equal to $-V_s/2$.

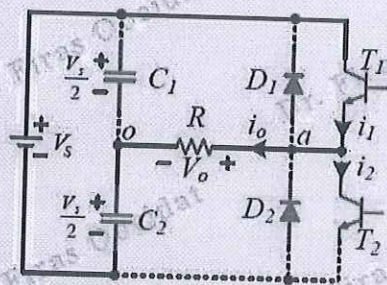
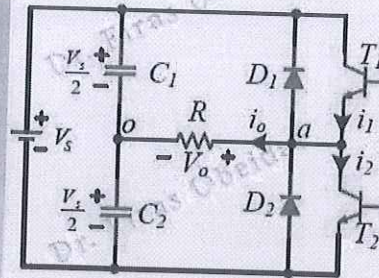

T_1 ON, T_2 OFF, $V_o = V_s/2$

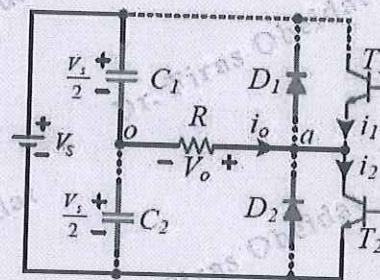

T_1 OFF, T_2 ON, $V_o = -V_s/2$

Single Phase Half Bridge Inverter – Resistive Load

The rms value for the output voltage can be found as

$$V_{o,rms} = \sqrt{\frac{2}{T} \int_0^{T/2} \left(\frac{V_s}{2}\right)^2 dt} = \frac{V_s}{2}$$

- When T_1 is ON through the period $0 < t < T/2$, the output current equal to $V_s/2R$.
- When T_2 is ON through the period $T/2 < t < T$, the output current equal to $-V_s/2R$.

The output voltage frequency is

$$f_o = \frac{1}{T}$$

The frequency can be changed by controlling the conduction time of the transistors.

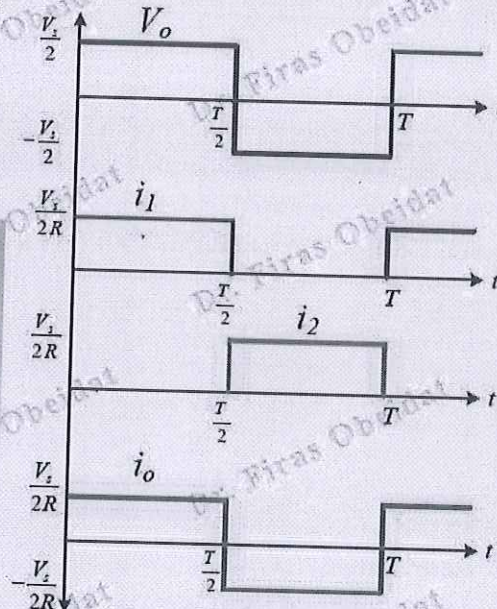



School of Electrical Skills
Session: 2020-21 (Summer Semester)
B. Voc. Program, 5th Semester,
End-Sem. Examination

Course Code: ELE 1502

Time: 2 Hours

Course Name: Substation Practices and Supervision

Max. Marks: 50

Instruction: Answer all questions from section A, each question carries one mark. Answer all questions from section B, each question carries four marks. Answer all questions from section C, each question carries six marks. Scientific calculator is allowed.

Section – A

10X01 = 10 Marks

1. A tariff should be such that it encourages the consumers to have low power factor.
(a) True (b) False
2. Two-part tariff is generally used for:
(a) Industrial consumers (b) Residential consumers
(c) Agriculture consumers (d) Commercial consumers
3. A tariff should provide incentive for using power during off-peak hours.
(a) True (b) False
4. are generally charged through block meter rate.
(a) Industrial consumers
(b) Residential consumers
(c) Commercial consumers
(d) Both (b) and (c)
5. Bus coupler circuit breaker is utilized in a substation for:
(a) Joining the transmission line with station bus-bar
(b) Joining main and transfer bus in a substation
(c) Joining the generator with transfer
(d) Joining the neutral of the generator with earth
6. Which of the following busbar arrangement is generally employed in distribution system?
(a) One-end-half breaker arrangement
(b) Main and transfer arrangement
(c) Ring main distribution system
(d) Single busbar arrangement system
7. Stones are provided in the substation to
(a) To avoid accident by draining oil from transformer if leaks
(b) To avoid growing of weeds and plants
(c) To provide insulation
(d) All the above
8. Depreciation is generated due to:
(a) Increase in the value of liability
(b) Decrease in capital
(c) Wear and tear
(d) Decrease in the value of assets
9. According to straight line method of providing depreciation, the depreciation:
(a) Remains constant
(b) Increase each year.
(c) Decrease each year
(d) None of them.

Prakash
A



10. Salvage value means:

- (a) Definite sale price of the asset
- (b) Cash to be received when life of the asset ends
- (c) Cash to be paid when asset is disposed off
- (d) Estimated disposal value

Section – B

04X04 = 16 Marks

- 1. What is depreciation reserve? Why is it necessary to maintain it?
- 2. What are the functions of a substation?
- 3. What are the objectives of Indian Electricity Grid Code (IEGC) or Grid Code?
- 4. What do you understand by Tariff and what are its objectives?

Section – C

04X06 = 24 Marks

- 1. The monthly electricity consumption of a residence can be approximated as under:
 - Light load = 5 tube lights 40 watt each working for 3 hours daily
 - Fan load = 3 fans 100 watt each working for 5 hours daily
 - Refrigerator load = 1 kWh daily
 - Misc. load = 1 kW for one hour dailyFind the monthly bill at the following tariff
 - First 15 units = Rs. 2.74 per kWh
 - Next 25 units = Rs. 2.70 per kWh
 - Remaining units = Rs. 2.32 per kWh
 - Constant charge = Rs. 7.00 per month
 - Discount for prompt payment 5%
- 2. A power station is erected at a cost of Rs 2×10^8 . Assuming a salvage value of 15% a useful life of 25 years and interest rate 8%, find the annual depreciation reserve
 - (a) By straight line method
 - (b) By sinking fund method
 - (c) By fixed percentage method
- 3. Determine the generation cost per unit of energy from the following plant data:
 - Installed Capacity = 120 MW
 - Capital Cost of Plant = Rs. 40000 per kW
 - Interest and depreciation = 15%
 - Fuel consumption = 0.64 kg/kWh
 - Fuel Cost = Rs. 1500 per 1000 kg
 - Salaries, wages, repairs and other operating costs per annum = Rs. 50,000,000
 - Peak load = 100 MW
 - Load Factor = 60%
- 4. A large industrial undertaking has a maximum demand of 50 MW at a load factor of 0.5. It has the option of getting supply from a utility or of installing its own plant.
The costs are as under:
 - Public supply tariff = Rs. 600 per kW of maximum demand per year + Rs. 2.50 per kWh
 - Private plant
 - Reserve capacity 20 MW
 - Capital Investment Rs. 30000 per kW
 - Interest and depreciation 15%
 - Fuel consumption 0.6% kg/kWh
 - Fuel cost Rs. 1400 per 1000 kg.
 - Wages, repair and other operating expenses = R. 0.80 per kWhFind out the cheaper alternative.



(Ans. Key ELE 1502 Set – A)

BHARTIYA SKILL DEVELOPMENT UNIVERSITY

School of Electrical Skills
Session: 2020-21 (Summer Semester)
B. Voc. Program, Vth Semester,
End-Sem. Examination

Course Code: ELE 1502

Time: 2 Hours

Course Name: Substation Practices and Supervision

Max. Marks: 50

Section – A

10X01 = 10 Marks

1. A tariff should be such that it encourages the consumers to have low power factor.
 - a) True
 - b) False**
2. Two part tariff is generally used for
 - a) Industrial consumers**
 - b) Residential consumers
 - c) Agriculture consumers
 - d) Commercial consumers
3. A tariff should provide incentive for using power during off-peak hours.
 - a) True**
 - b) False
4. are generally charged through block meter rate.
 - a) Industrial consumers
 - b) Residential consumers
 - c) Commercial consumers
 - d) Both (b) and (c)**
5. Bus coupler circuit breaker is utilized in a substation for
 - a) Joining the transmission line with station bus-bar
 - b) Joining main and transfer bus in a substation**
 - c) Joining the generator with transfer
 - d) Joining the neutral of the generator with earth
6. which of the following busbar arrangement is generally employed in distribution system
 - a) One-end-half breaker arrangement
 - b) Main and transfer arrangement
 - c) Ring main distribution system**
 - d) Single busbar arrangement system
7. Stones are provided in the substation to
 - a) To avoid accident by draining oil from transformer if leaks
 - b) To avoid growing of weeds and plants
 - c) To provide insulation
 - d) All the above**
8. Depreciation is generated due to
 - a) Increase in the value of liability
 - b) Decrease in capital
 - c) Wear and tear**
 - d) Decrease in the value of assets



9. According to straight line method of providing depreciation, the depreciation

- a) **Remains constant**
- b) Increase each year.
- c) Decrease each year
- d) None of them.

10. Salvage value means

- a) Definite sale price of the asset
- b) Cash to be received when life of the asset ends
- c) Cash to be paid when asset is disposed off
- d) **Estimated disposal value**

Section – B

04X04 = 16 Marks

1. What is depreciation reserve? Why is it necessary to maintain it?

Ans:

Depreciation is an accounting method of allocating the cost of a tangible or physical asset over its useful life or life expectancy. **Depreciation** represents how much of an asset's value has been used up.

The value of the power plant decreases from its initial value to the salvage value at the end of its useful life. This depreciation is due to ageing, wear and tear of machinery, corrosion, weathering, inadequacy and obsolescence of equipment etc. At the end of the useful life of the plant, funds must be available to replace the equipment. The depreciation charge represents the amount which is set aside from income every year and placed in depreciation reserve. For calculating this charge, it is necessary to estimate the useful life of plant.

2. What are the functions of a substation?

Ans: The functions of an electric substations are:

- ✓ It receives electric energy from an incoming line at a voltage and supplies the same to outgoing lines at a reduced voltage level employing power transformers.
- ✓ It acts as a connection point for local networks.
- ✓ It regulates voltage to compensate for system voltage drop by injecting reactive power to the transmission or distribution circuits.
- ✓ It acts as a monitoring point for control centre using current and potential transformers.
- ✓ It acts as a switchyard for switching electric transmission and distribution circuits into and out of the system using bus bars, circuit-breakers and isolators.
- ✓ It protects the electric system insulation against abnormal over voltages caused due to lightning and switching, employing protective devices like surge diverters.
- ✓ It protects the system equipments against abnormal short-circuit currents employing relays and circuit-breakers.

3. What are the objectives of Indian Electricity Grid Code (IEGC) or Grid Code?



BHARTIYA SKILL DEVELOPMENT UNIVERSITY

Ans: The IEGC brings together a single set of technical and commercial rules, encompassing all the Utilities connected to/or using the inter-State transmission system (ISTS) and provides the following:

- ✓ Documentation of the principles and procedures which define the relationship between the various Users of the inter-State transmission system (ISTS), National Load Despatch Centre, as well as the Regional and State Load Despatch Centres
 - ✓ Facilitation of the optimal operation of the grid, facilitation of coordinated and optimal maintenance planning of the grid and facilitation of development and planning of economic and reliable National / Regional Grid
 - ✓ Facilitation for development of power markets by defining a common basis of operation of the ISTS, applicable to all the Users of the ISTS.
 - ✓ Facilitation of the development of renewable energy sources by specifying the technical and commercial aspects for integration of these resources into the grid.
4. What do you understand by Tariff and what are its objectives?

Ans: Electric utilities derive their income from customers through electricity bills. Different methods of charging customers are known as tariffs. A tariff should fulfill the following objectives and requirements:

1. Cost of capital investment in generation, transmission and distribution equipment must be recovered.
2. Cost of operation, supplies, maintenance and losses must be recovered.
3. Cost of metering, billing, collection and miscellaneous services must be recovered.
4. A satisfactory net return on the capital investment must be ensured.
5. It should be simple and comprehensible to the public.
6. It should be uniform over large population.
7. It should be such that persons creating a desirable and relatively inexpensive type of load make full use and benefit of the electrical appliances.
8. It should provide incentive for using power during the off-peak hours.
9. It should have a provision for higher demand charges for high loads demanded at system peak.
10. It should have a provision of penalty for low factors.
11. It should apportion equitably the cost of service to the different categories of consumers.

Section – C

04X06 = 24 Marks

1. The monthly electricity consumption of a residence can be approximated as under:
 - Light load = 5 tube lights 40 watt each working for 3 hours daily
 - Fan load = 3 fans 100 watt each working for 5 hours daily
 - Refrigerator load = 1 kWh daily
 - Misc. load = 1 kW for one hour dailyFind the monthly bill at the following tariff
First 15 units = Rs. 2.74 per kWh



BHARTIYA SKILL DEVELOPMENT UNIVERSITY

Next 25 units = Rs. 2.70 per kWh

Remaining units = Rs. 2.32 per kWh

Constant charge = Rs. 7.00 per month

Discount for prompt payment 5%

Ans: Total energy consumption in 30 days = $(5 \times 40 \times 3 \times 30 + 3 \times 100 \times 5 \times 30) \times (1/1000) + 30 + 30 = 18 + 45 + 30 + 30 = 123$ Units

The monthly bill = Rs. $(7.00 + 2.74 \times 15 + 2.70 \times 25 + 2.32 \times 83) =$ Rs 308.16

The net monthly bill = $308.16 \times 0.95 =$ Rs. 292.76

2. A power station is erected at a cost of Rs 2×10^8 . Assuming a salvage value of 15% a useful life of 25 years and interest rate 8%, find the annual depreciation reserve

- (a) By straight line method
- (b) By sinking fund method
- (c) By fixed percentage method

Ans: (a) Annual straight line depreciation reserve = Rs. $2 \times 10^8 (1 - 0.15) / 25$

(b) Annual sinking fund depreciation reserve = Rs. $[2 \times 10^8 (1 - 0.15)] [0.08 / \{(1.08)^{25} - 1\}]$

(c) $C =$ Rs. 2×10^8 , $n = 25$ years, $S =$ Rs. $2 \times 10^8 \times 0.15$

$1 - x/100 = (0.15)^{1/25} = 0.927$ or $x = 7.3\%$

3. Determine the generation cost per unit of energy from the following plant data:

Installed Capacity = 120 MW

Capital Cost of Plant = Rs. 40000 per kW

Interest and depreciation = 15%

Fuel consumption = 0.64 kg/kWh

Fuel Cost = Rs. 1500 per 1000 kg

Salaries, wages, repairs and other operating costs per annum = Rs. 50,000,000

Peak load = 100 MW

Load Factor = 60%

Ans:

Average load	= $100 \times 0.6 = 60$ MW
Energy generated	= $60 \times 1000 \times 8760 = 5256 \times 10^5$ kW-hr
Total Investment	= $120 \times 10^3 \times 40000 =$ Rs. 4800×10^6
Interest and depreciation	= Rs. $4800 \times 10^6 \times \frac{15}{100} =$ Rs. 720×10^6 per year
Fuel consumption	= $0.64 \times 5256 \times 10^5$ kg/year = 3363.84×10^5 kg per year
Fuel cost	= Rs. $3363.84 \times 10^5 \times \frac{1500}{1000}$ per year
	= Rs. 504.576×10^6 per year
Salaries, wages etc.	= Rs. 50×10^6 per year
Annual Plant cost	= Rs. 1274.576×10^6 per year
Generation cost	= Rs. $\frac{1274.576 \times 10^6}{5256 \times 10^5} =$ Rs. 2.425/kWh

4. A large industrial undertaking has a maximum demand of 50 MW at a load factor of 0.5. It has the option of getting supply from a utility or of installing its own plant.

The costs are as under:

Public supply tariff = Rs. 600 per kW of maximum demand per year + Rs. 2.50 per kWh

Private plant

Reserve capacity 20 MW

Capital Investment Rs. 30000 per kW

Interest and depreciation 15%

Fuel consumption 0.6% kg/kWh

Fuel cost Rs. 1400 per 1000 kg.

Wages, repair and other operating expenses = R. 0.80 per kWh



Ans:

Solution. Average load = $50 \times 0.5 = 25 \text{ MW}$
Energy consumption per year = $25 \times 1000 \times 8760 = 219 \times 10^6 \text{ kWh}$
(a) Annual expenditure in getting supply from utility
= Rs. $50 \times 1000 \times 600 + 2.5 \times 219 \times 10^6$
= Rs. $30 \times 10^6 + \text{Rs. } 547.5 \times 10^6$
= Rs. 577.5×10^6 per year
(b) Private Steam Plant
Installed capacity = $50 + 20 = 70 \text{ MW}$
Capital Investment = $30000 \times 70 \times 1000 = \text{Rs. } 2100 \times 10^6$
Interest and depreciation = $\text{Rs. } 2100 \times 10^6 \times \frac{15}{100} = \text{Rs. } 315 \times 10^6$ per year
Fuel consumption = $219 \times 10^6 \times 0.6 \text{ kg/year} = 131.4 \times 10^6 \text{ kg/year}$
Fuel cost per year = $131.4 \times 10^6 \times \frac{1400}{1000} = \text{Rs. } 183.96 \times 10^6$ per year
Wages, repair and other operating expenses per year = $219 \times 10^6 \times 0.80 = \text{Rs. } 175.2 \times 10^6$ per year
Total expenditure per year = $\text{Rs. } 315 \times 10^6 + 183.96 \times 10^6 + 175.2 \times 10^6$
= Rs. 674.16×10^6 per year
Evidently it would be cheaper to buy electricity from the utility.



School of Electrical Skills
Session: 2020-21 (Summer Semester)
B. Voc. Program, 5th Semester,
End-Sem. Examination

Course Code: ELE 1502**Time: 2 Hours****Course Name: Substation Practices and Supervision****Max. Marks: 50**

Instruction: Answer all questions from section A, each question carries one mark. Answer all questions from section B, each question carries four marks. Answer all questions from section C, each question carries six marks. Scientific calculator is allowed.

Section – A

10X01 = 10 Marks

1. A tariff should be such that it encourages the consumers to have low power factor.
(a) True (b) False
2. Two-part tariff is generally used for:
(a) Industrial consumers (b) Residential consumers
(c) Agriculture consumers (d) Commercial consumers
3. A tariff should provide incentive for using power during off-peak hours.
(a) True (b) False
4. are generally charged through block meter rate.
(a) Industrial consumers
(b) Residential consumers
(c) Commercial consumers
(d) Both (b) and (c)
5. In substation which of the device is a carrier communication device:
(a) CVT
(b) Earth conductor
(c) Wave trap
(d) Lightning arrestor
6. Which among these types of bus bars can be used outdoor?
(a) Tubular
(b) ACSR
(c) AAC
(d) All of these
(e) None of these
7. Which sequence is followed first while closing a circuit breaker?
(a) Close the isolator
(b) Open earthing switch
(c) Close circuit breaker
(d) Any of these
8. Depreciation is generated due to:
(a) Increase in the value of liability
(b) Decrease in capital
(c) Wear and tear
(d) Decrease in the value of assets
9. According to straight line method of providing depreciation, the depreciation:
(a) Remains constant
(b) Increase each year.
(c) Decrease each year
(d) None of these



10. Salvage value means:

- (a) Definite sale price of the asset
- (b) Cash to be received when life of the asset ends
- (c) Cash to be paid when asset is disposed off
- (d) Estimated disposal value

Section – B

04X04 = 16 Marks

- 1. What is depreciation reserve? Why is it necessary to maintain it?
- 2. What is substation? Classify the substations according to the operating voltages and importance features.
- 3. Which factors affect the power system security?
- 4. What do you understand by Tariff and what are its objectives?

Section – C

04X06 = 24 Marks

- 1. The monthly electricity consumption of a residence can be approximated as under:
 - Light load = 5 tube lights 40 watt each working for 3 hours daily
 - Fan load = 3 fans 100 watt each working for 5 hours daily
 - Refrigerator load = 1 kWh daily
 - Misc. load = 1 kW for one hour dailyFind the monthly bill at the following tariff
 - First 15 units = Rs. 2.74 per kWh
 - Next 25 units = Rs. 2.70 per kWh
 - Remaining units = Rs. 2.32 per kWh
 - Constant charge = Rs. 7.00 per month
 - Discount for prompt payment 5%
- 2. A power station is erected at a cost of Rs 2×10^8 . Assuming a salvage value of 15% a useful life of 25 years and interest rate 8%, find the annual depreciation reserve
 - (a) By straight line method
 - (b) By sinking fund method
 - (c) By fixed percentage method
- 3. A residential consumer has the following connected ; 8 bulbs of 100 W each , 2 fans 60 W each and 2 light plug points of 100 W each . His use of electricity during a day is as under:

12 midnight to 5 am	One fan
5 am to 7 am	Two fans and one light point
7 am to 9 am	NIL
9 am to 6 pm	Two fans
6 pm to midnight	Two fans and four bulbs

Find (a) connected load (b) maximum demand (c) demand factor
- 4. A large industrial undertaking has a maximum demand of 50 MW at a load factor of 0.5. It has the option of getting supply from a utility or of installing its own plant.
The costs are as under:
 - Public supply tariff = Rs. 600 per kW of maximum demand per year + Rs. 2.50 per kWh
 - Private plant
 - Reserve capacity 20 MW
 - Capital Investment Rs. 30000 per kW
 - Interest and depreciation 15%
 - Fuel consumption 0.6% kg/kWh
 - Fuel cost Rs. 1400 per 1000 kg.
 - Wages, repair and other operating expenses = R. 0.80 per kWhFind out the cheaper alternative.



(Ans. Key ELE 1502 Set – B)
BHARTIYA SKILL DEVELOPMENT UNIVERSITY

Registration No.:.....

School of Electrical Skills
Session: 2020-21 (Summer Semester)
B. Voc. Program, Vth Semester,
End-Sem. Examination

Course Code: ELE 1502

Course Name: Substation Practices and Supervision
Section – A

Max. Marks: 50

10X01 = 10 Marks

1. A tariff should be such that it encourages the consumers to have low power factor.

- a) True
- b) False**

2 Two part tariff is generally used for

- a) Industrial consumers**
- b) Residential consumers
- c) Agriculture consumers
- d) Commercial consumers

3. A tariff should provide incentive for using power during off-peak hours.

- a) True**
- b) False

4. are generally charged through block meter rate.

- a) Industrial consumers
- b) Residential consumers
- c) Commercial consumers
- d) Both (b) and (c)**

5. In substation which of the device is a carrier communication device

- a) CVT
- b) Earth conductor
- c) Wave trap**
- d) Lightning arrestor

6. Which among these types of bus bars can be used outdoor?

- a) Tubular
- b) ACSR
- c) AAC
- d) All of these**
- e) None of these

7. Which sequence is followed first while closing a circuit breaker?

- a) Close the isolator
- b) Open earthing switch**
- c) Close circuit breaker
- d) Any of these

8. Depreciation is generated due to

- a) Increase in the value of liability
- b) Decrease in capital
- c) Wear and tear**
- d) Decrease in the value of assets



9. According to straight line method of providing depreciation, the depreciation

- a) Remains constant
- b) Increase each year.
- c) Decrease each year
- d) None of them.

10. Salvage value means

- a) Definite sale price of the asset
- b) Cash to be received when life of the asset ends
- c) Cash to be paid when asset is disposed off
- d) Estimated disposal value

Section – B

04X04 = 16 Marks

1. What is depreciation reserve? Why is it necessary to maintain it?

Ans:

Depreciation is an accounting method of allocating the cost of a tangible or physical asset over its useful life or life expectancy. **Depreciation** represents how much of an asset's value has been used up.

The value of the power plant decreases from its initial value to the salvage value at the end of its useful life. This depreciation is due to ageing, wear and tear of machinery, corrosion, weathering, inadequacy and obsolescence of equipment etc. At the end of the useful life of the plant, funds must be available to replace the equipment. The depreciation charge represents the amount which is set aside from income every year and placed in depreciation reserve. For calculating this charge, it is necessary to estimate the useful life of plant.

2. What is substation? Classify the substations according to the operating voltages and importance features.

Substation: A power substation is a subsidiary station of an electricity generation, transmission and distribution system where voltage is transformed from high or medium to low or the reverse using transformers. Electric power flows through several substations between generating plant and consumer changing the voltage level in several stages. At first substations were connected to only one power station where the generator was housed and were subsidiaries of that power station.

Generally, electrical substation is a point in distribution system where:

- A place where several electrical equipments are installed and used for electrical energy in power system.
- A place where the safety of the system is provides by automatically protection scheme.
- A place where one or several incoming and outgoing circuit are met at one or more busbar system and controlled by high voltage switching equipment which is used for switching.
- A place where voltage value is changed and controlled.
- A place where load are distributed, controlled and protected



BHARTIYA SKILL DEVELOPMENT UNIVERSITY

Classification of Substation on the basis of operating voltage: The substations, according to operating voltage, may be categorized as

1. High Voltage Substations (HV Substations): involving voltages between 11 kV and 66 kV.
2. Extra High Voltage Substations (EHV Substations): involving voltages between 132 kV and 400 kV.
3. Ultra High Voltage Substations (UHV Substations): operating on voltage above 400 kV.

Classification of Substation on the basis of importance:

1. Grid Substations: these are the substations from where bulk power is transmitted from point to another point in the grid. These are important because any disturbance in these substations may cause the failure of the grid.
2. Town Substations: these substations step-down the voltages at 33/11 kV for further distribution in the towns and any failure in such substations results in the failure of supply for whole of the town.

3. Which factors affect the power system security?

Ans: As a consequence of many widespread blackouts in interconnected power systems, the priorities for operation of modern power system have evolved to the following:

1. Operate the system in such a way that power is delivered reliably.
2. Within the constraints placed on the system operation by reliability considerations, the system will be operated most economically.
 - Engineering groups who have designed the power system's transmission and generation systems have done so with reliability in mind.
 - This means that adequate generation has been installed to meet the load and that adequate transmission has been installed to deliver the generated power to the load.
 - If the operation of the system went on without sudden failures or without experiencing unanticipated operating states, we would probably have no reliability problems.
 - However, any piece of equipment in the system can fail, either due to internal causes or due to external causes such as lightning strikes, object hitting transmission towers, or human errors in setting relays.

There are two major types of failure events,

1. Transmission line outages
2. Generation unit failures

Transmission line failures cause changes in the line flows and voltages on the transmission equipment remaining connected to the system. Therefore, the analysis of transmission



failures requires a method to predict these flows and voltages to be sure they are within their respective limits.

Generation failures can also cause line flows and voltages to change in the transmission system, with the addition of dynamic problems involving system frequency and generator output.

4. What do you understand by Tariff and what are its objectives?

Ans: Electric utilities derive their income from customers through electricity bills.

Different methods of charging customers are known as tariffs. A tariff should fulfill the following objectives and requirements:

1. Cost of capital investment in generation, transmission and distribution equipment must be recovered.
2. Cost of operation, supplies, maintenance and losses must be recovered.
3. Cost of metering, billing, collection and miscellaneous services must be recovered.
4. A satisfactory net return on the capital investment must be ensured.
5. It should be simple and comprehensible to the public.
6. It should be uniform over large population.
7. It should be such that persons creating a desirable and relatively inexpensive type of load make full use and benefit of the electrical appliances.
8. It should provide incentive for using power during the off-peak hours.
9. It should have a provision for higher demand charges for high loads demanded at system peak.
10. It should have a provision of penalty for low factors.
11. It should apportion equitably the cost of service to the different categories of consumers.

Section – C

04X06 = 24 Marks

1. The monthly electricity consumption of a residence can be approximated as under:

Light load = 5 tube lights 40 watt each working for 3 hours daily

Fan load = 3 fans 100 watt each working for 5 hours daily

Refrigerator load = 1 kWh daily

Misc. load = 1 kW for one hour daily

Find the monthly bill at the following tariff

First 15 units = Rs. 2.74 per kWh

Next 25 units = Rs. 2.70 per kWh

Remaining units = Rs. 2.32 per kWh

Constant charge = Rs. 7.00 per month

Discount for prompt payment 5%

Ans: Total energy consumption in 30 days = $(5 \times 40 \times 3 \times 30 + 3 \times 100 \times 5 \times 30) \times (1/1000) + 30 + 30 = 18 + 45 + 30 + 30 = 123$ Units

The monthly bill = Rs. $(7.00 + 2.74 \times 15 + 2.70 \times 25 + 2.32 \times 83) =$ Rs 308.16

The net monthly bill = $308.16 \times 0.95 =$ Rs. 292.76



BHARTIYA SKILL DEVELOPMENT UNIVERSITY

2. A power station is erected at a cost of Rs 2×10^8 . Assuming a salvage value of 15% a useful life of 25 years and interest rate 8%, find the annual depreciation reserve
- (a) By straight line method
 - (b) By sinking fund method
 - (c) By fixed percentage method

Ans: (a) Annual straight line depreciation reserve = Rs. $2 \times 10^8(1-0.15)/25$

(b) Annual sinking fund depreciation reserve = Rs. $[2 \times 10^8 (1-0.15)][0.08/\{(1.08)^{25} - 1\}]$

(c) $C = Rs. 2 \times 10^8$, $n = 25$ years, $S = Rs. 2 \times 10^8 \times 0.15$

$$1 - x/100 = (0.15)^{1/25} = 0.927 \text{ or } x = 7.3\%$$

3. A residential consumer has the following connected ; 8 bulbs of 100 W each , 2 fans 60 W each and 2 light plug points of 100 W each . His use of electricity during a day is as under:

12 midnight to 5 am	One fan
5 am to 7 am	Two fans and one light point
7 am to 9 am	NIL
9 am to 6 pm	Two fans
6 pm to midnight	Two fans and four bulbs

Find (a) connected load (b) maximum demand (c) demand factor

Solution. (a) Connected load = $8 \times 100 + 2 \times 60 + 2 \times 100 = 1120$ W

(b) Total wattage at different times is

12 midnight to 5 am	60 W
5 am to 7 am	$2 \times 60 + 1 \times 100 = 200$ W
7 am to 9 am	NIL
9 am to 6 pm	$2 \times 60 = 120$ W
6 pm to midnight	$2 \times 60 + 4 \times 100 = 520$ W

The maximum demand is 520 W

(c) Demand Factor = $520/1120 = 0.464$

4. A large industrial undertaking has a maximum demand of 50 MW at a load factor of 0.5. It has the option of getting supply from a utility or of installing its own plant.

The costs are as under:

Public supply tariff = Rs. 600 per kW of maximum demand per year + Rs. 2.50 per kWh

Private plant

Reserve capacity 20 MW

Capital Investment Rs. 30000 per kW

Interest and depreciation 15%

Fuel consumption 0.6% kg/kWh

Fuel cost Rs. 1400 per 1000 kg.

Wages, repair and other operating expenses = R. 0.80 per kWh

Find out the cheaper alternative.



Solution. Average load = $50 \times 0.5 = 25 \text{ MW}$
Energy consumption per year = $25 \times 1000 \times 8760 = 219 \times 10^6 \text{ kWh}$

(a) Annual expenditure in getting supply from utility
= $\text{Rs. } 50 \times 1000 \times 600 + 2.5 \times 219 \times 10^6$
= $\text{Rs. } 30 \times 10^6 + \text{Rs. } 547.5 \times 10^6$
= $\text{Rs. } 577.5 \times 10^6 \text{ per year}$

(b) Private Steam Plant

Installed capacity = $50 + 20 = 70 \text{ MW}$

Capital Investment = $30000 \times 70 \times 1000 = \text{Rs. } 2100 \times 10^6$

Interest and depreciation = $\text{Rs. } 2100 \times 10^6 \times \frac{15}{100} = \text{Rs. } 315 \times 10^6 \text{ per year}$

Fuel consumption = $219 \times 10^6 \times 0.6 \text{ kg/year} = 131.4 \times 10^6 \text{ kg/year}$

Fuel cost per year = $131.4 \times 10^6 \times \frac{1400}{1000} = \text{Rs. } 183.96 \times 10^6 \text{ per year}$

Wages, repair and other operating expenses per year

= $219 \times 10^6 \times 0.80 = \text{Rs. } 175.2 \times 10^6 \text{ per year}$

Total expenditure per year = $\text{Rs. } 315 \times 10^6 + 183.96 \times 10^6 + 175.2 \times 10^6$

= $\text{Rs. } 674.16 \times 10^6 \text{ per year}$

Evidently it would be cheaper to buy electricity from the utility.

**BHARTIYA SKILL DEVELOPMENT UNIVERSITY**

School of Electrical Skills
Session 2020 -21 (Summer Semester)
B. Voc. Program, 5th Semester,
End – Semester Examination

Course Code: ELE 1503**Time: 2 Hours****Course Name: Electrical Machines – II****Max. Marks: 50**

Instructions: Answer all questions from section A, each question carries one mark. Answer all questions from section B, each question carries four marks. Answer all questions from section C, each question carries six marks. Scientific calculator is allowed.

Section – A**10X01 = 10 Marks**

- Natural speed at which a magnetic field rotates is defined as:
(a) Synchronous speed of an induction motor (b) The rotor speed of an induction motor
(c) The speed of an induction motor at no load (d) None of these
- If the stator frequency of an induction motor is F_s , then the rotor frequency F_r is given by:
(a) $F_r = S \cdot F_s$ (b) $F_r = S / F_s$ (c) $F_r = 1 / S \cdot F_s$ (d) None of these
- In a shaded pole single-phase motor, the revolving field is produced by the use of:
(a) Inductor (b) Capacitor (c) Resistor (d) Shading coils
- For an induction motor, given $f = 60$ Hz, $N_s = 1800$ rpm the number of poles in the machine is:
(a) 1 (b) 2 (c) 3 (d) 4
- The emf induced in the rotor of an induction motor is proportional to:
(a) Voltage applied to stator (b) Relative velocity between flux and rotor conductors
(c) Both (a) and (b) (d) Slip
- Which of the following applications make use of a universal motor?
(a) Portable tools (b) Lathe machines
(c) Oil expeller (d) Floor polishing machine
- The purpose of stator winding in the compensated repulsion motor is to:
(a) Provide mechanical balance (b) Improve power factor and provide better speed regulation
(c) Prevent hunting in the motor (d) Eliminate armature reaction
- In an induction motor, no-load the slip is generally:
(a) less than 1% (b) 1.5% (c) 2% (d) 4%
- Number of Slip Rings in squirrel cage induction motor is:
(a) 0 (b) 1 (c) 2 (d) 4
- In case the air gap in an induction motor is increased, then:
(a) The magnetising current of the rotor will decrease (b) The power factor will decrease
(c) speed of motor will increase (d) None of these

Section – B**04x04 = 16 Marks**

- 3 Phase induction motor does not run at synchronous speed, why?
- What are the need of Parallel Operation of alternator?
- What do you mean by Cogging?
- What are the difference between Concentrated and Distributed winding?

Section – C**04x06 = 24 Marks**

- Explain No-Load and Blocked Rotor Test of 3 phase induction motor.
- Explain working of Direct On Line Starter with the help of a neat sketch.
- State the advantages and disadvantages of stepper motor.
- For a 3 phase induction motor draws 80kW from the 3 phase source. Given that Synchronous Speed $N_s = 1200$ RPM, Rotor speed $N_r = 1152$ RPM, Total stator loss = 5KW. Find the Rotor output power produced by the machine.



BHARTIYA SKILL DEVELOPMENT UNIVERSITY

School of Electrical Skills
5th Semester, End – Semester Examination
B. Voc. Program, Summer Semester (2020-21)

Course Code: ELE 1503

Course Name: Electrical Machines – II

Time: 2 Hours

Max. Marks: 50

Section – A

10X01 = 10 Marks

1. Natural speed at which a magnetic field rotates is defined as:
(a) Synchronous speed of an induction motor (b) The rotor speed of an induction motor
(c) The speed of an induction motor at no load (d) None of these
2. If the stator frequency of an induction motor is F_s , then the rotor frequency F_r is given by:
(a) $F_r = S * F_s$ (b) $F_r = S / F_s$ (c) $F_r = 1 / S * F_s$ (d) None of these
3. In a shaded pole single-phase motor, the revolving field is produced by the use of:
(a) Inductor (b) Capacitor (c) Resistor **(d) Shading coils**
4. For an induction motor, given $f = 60$ Hz, $N_s = 1800$ rpm the number of poles in the machine is:
(a) 1 (b) 2 (c) 3 **(d) 4**
5. The emf induced in the rotor of an induction motor is proportional to:
(a) Voltage applied to stator (b) Relative velocity between flux and rotor conductors
(c) Both (a) and (b) (d) Slip
6. Which of the following applications make use of a universal motor?
(a) Portable tools (b) Lathe machines
(c) Oil expeller (d) Floor polishing machine
7. The purpose of stator winding in the compensated repulsion motor is to:
(a) Provide mechanical balance **(b) Improve power factor and provide better speed regulation**
(c) Prevent hunting in the motor (d) Eliminate armature reaction
8. In an induction motor, no-load the slip is generally:
(a) less than 1% (b) 1.5% (c) 2% (d) 4%
9. Number of Slip Rings in squirrel cage induction motor is:
(a) 0 (b) 1 (c) 2 (d) 4
10. In case the air gap in an induction motor is increased, then:
(a) The magnetising current of the rotor will decrease **(b) The power factor will decrease**
(c) speed of motor will increase (d) None of these

Section – B

04x04 = 16 Marks

1. **3 Phase induction motor does not run at synchronous speed, why?**
If rotor runs at the synchronous speed, which is the same speed of the rotating magnetic field, then the rotor will appear stationary to the rotating magnetic field and the rotating magnetic field will not cut the rotor. So, no induced current will flow in the rotor and no rotor magnetic flux will be produced so no torque is generated and the rotor speed will fall below the synchronous speed. When the speed falls, the rotating magnetic field will cut the rotor windings and a torque is produced
2. **What are the need of Parallel Operation of alternator?**
Alternators are operated in parallel for the following reasons:
 1. Several alternators can supply a bigger load than a single alternator.
 2. One or more alternators may shut down during the period of light loads. Thus, the remaining alternator operates at near or full load with greater efficiency.
 3. When one machine is taken out of service for its scheduled maintenance and inspection, the remaining machines maintain the continuity of the supply.
 4. If there is a breakdown of the generator, there is no interruption of the power supply.
 5. Number of machines can be added with disturbing the initial installation according to the requirement to fulfill the increasing future demand of the load.
 6. Parallel operation of the alternator, reduces the operating cost and the cost of energy generation.It ensures the greater security of supply and enables overall economic generation
3. **What do you mean by Cogging?**
Sometimes, the rotor of a squirrel cage induction motor refuses to start at all, particularly if the supply voltage is low. This happens especially when number of rotor teeth is equal to number of stator teeth, because of magnetic locking between the stator teeth and the rotor teeth. When the rotor teeth and stator teeth face each other, the reluctance of the magnetic path is minimum, that is why the rotor tends to remain fixed. This phenomenon is called cogging or **magnetic locking of induction motor.**

BHARTIYA SKILL DEVELOPMENT UNIVERSITY

4. What are the difference between Concentrated and Distributed winding?

Sr. No.	Concentrated Winding	Distributed Winding
1)	The coils of concentrated winding are co-axial. This means, all the winding coils have the same magnetic axis.	The coils of distributed windings are not co-axial. They are rather distributed in various slots along the air-gap periphery.
2)	The emf induced in the such winding is independent of pitch and distribution factor. $E = 1.414\pi f N \Phi$	The emf induced in the distributed winding is dependent on the value of pitch factor K_p and distribution factor K_d . $E = 1.414\pi K_p K_d f N \Phi$
3)	This type of winding is used in transformer, electromagnets etc.	Distributed winding is used in armature winding of induction machine, synchronous machine, DC machine etc.
4)	For concentrated winding, the number of pole is equal to number of slots.	Number of pole is not equal to number of slots.

Section – C

04x06 = 24 Marks

1. Explain No-Load and Blocked Rotor Test of 3 phase induction motor.

The no-load test of an induction motor is similar to the open-circuit test of a transformer. The motor is not connected from its load, and the rated voltage at the rated frequency is applied to the stator to run the motor without a load. The 2-wattmeter method measures the input power of the system. The voltmeter measures the standard-rated supply voltage and an ammeter measures the no-load current. Since the motor is running at no-load, total power is equal to the constant iron loss, friction and winding losses of the motor.

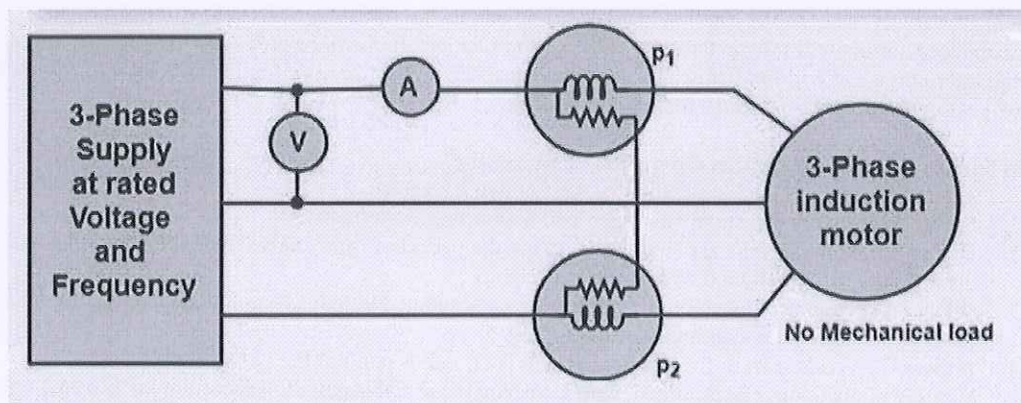

$$P_{\text{constant}} = P_i = P_1 + P_2 = \text{Sum of the two wattmeter readings.}$$

Since the power factor of the induction motor under a no-load condition is generally less than 0.5, one wattmeter will show a negative reading.

Therefore, it is, necessary to reverse the direction of current-coil terminals to take the reading.

If V_{inl} = input line voltage

P_{inl} = total 3-phase input power at no-load

I_0 = input line current.

V_{ip} = input phase voltage

BHARTIYA SKILL DEVELOPMENT UNIVERSITY

$$P_{inl} = \sqrt{3} V_{inl} I_0 \cos\Phi_0$$

$$I_{\mu} = I_0 \sin\Phi_0$$

$$I_{\omega} = I_0 \cos\Phi_0$$

$$R_0 = \frac{V_{ip}}{I_{\omega}}$$

$$X_0 = \frac{V_{ip}}{I_{\mu}}$$

2. Explain working of Direct On Line Starter with the help of a neat sketch.

Direct on line starter

The direct on line starter method, of an induction motor is simple and economical. In this method, the starter is connected directly to supply voltage. By this method small motors up to 5 kW rating is started to avoid the supply voltage fluctuation.

Direct On Line Starter Method is a common method of starting of Cage Induction Motor. The motor is connected through a starter across the full supply voltage. The **Direct On Line Starter Method** figure is shown below. It consists a coil operated contactor C controlled by start and stop push button as shown in the connection diagram below.

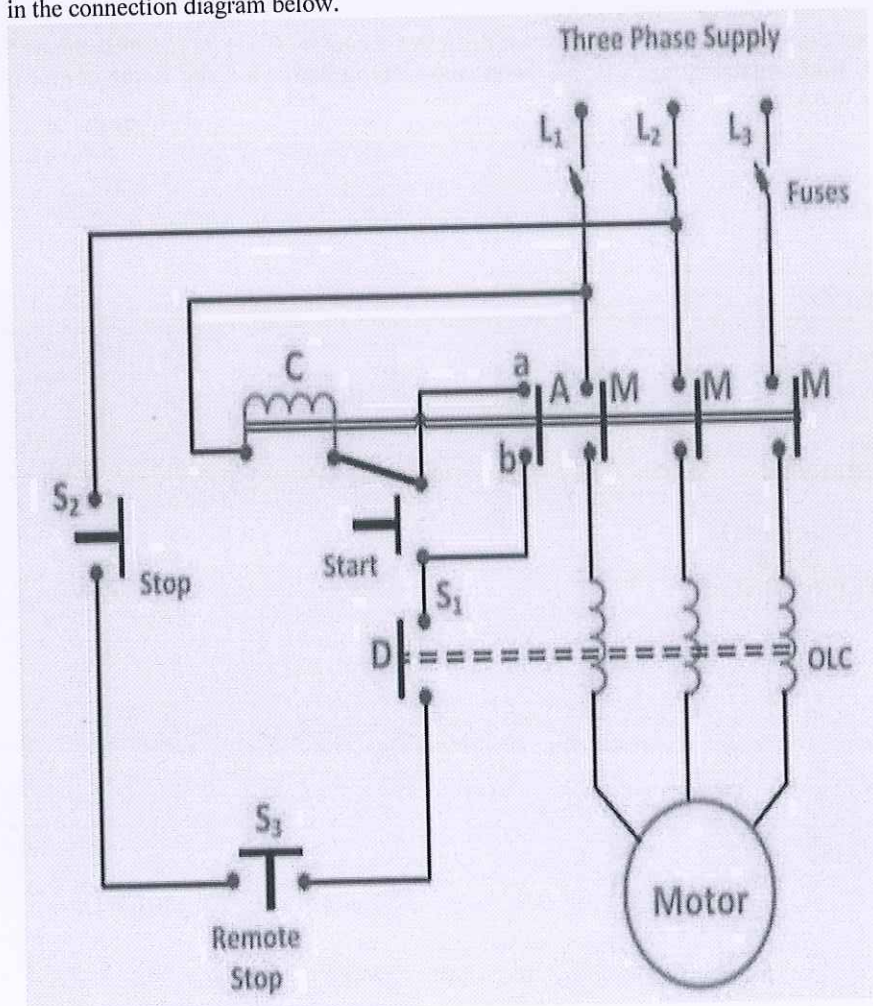

BHARTIYA SKILL DEVELOPMENT UNIVERSITY

The buttons which may be installed in a convenient place away from the starter. The start button is held open by a spring. On pressing the **START** pushbutton S_1 , the contactor C is energised from two line conductors L_1 and L_2 .

The three main contacts M and the auxiliary contact A are closed. The terminals a and b are short-circuited. The motor is then connected to the supply mains. The S_1 button moves back under the spring action as soon as the pressure is released. The coil C remains energised through ab .

Thus, the main contact M remains closed, and the motor continues to get supplies. Therefore, contact A is known as Hold-On-Contact. The stop button S_2 is normally held closed by the spring. If the S_2 button is pressed to **STOP** the motor, the supply through the contactor coil C is disconnected. As the coil C is de-energised, the main contacts M and the auxiliary contact A are opened. The supply to the motor is disconnected, and the motor is stopped.

3. State the advantages and disadvantages of stepper motor.

Advantages of Stepper Motor

- The various benefits of the Stepping Motor are as follows:-
- The motor is simple in construction, reliable.
- At the standstill condition, the motor has full torque.
- The motors are less costly.
- They require little maintenance.
- The stepper motor has an excellent and accurate starting, stopping and reversing response.

Disadvantages of Stepper Motor

- The motor uses more current as compared to the DC motor.
- At the higher speed, the value of torque reduces.
- Lower efficiency.
- The Resonance condition arises and requires micro stepping.
- At the high speed, the control is not possible.

4. For a 3 phase induction motor draws 80kW from the 3 phase source. Given that Synchronous Speed $N_s = 1200$ RPM, Rotor speed $N_r = 1152$ RPM, Total stator loss = 5Kw. Find the Rotor output power produced by the machine.

$$P_i = 80 \text{ kW}$$

$$S_o, P_g = 80 - 5 = 75 \text{ kW}$$

$$P_m = P_g - P_{r\text{loss}}$$

$$P_{r\text{loss}} = P_g - P_m$$

$$P_{r\text{loss}} = T\omega_s - T\omega_r$$

$$= T(\omega_s - \omega_r)$$

$$= T\omega_s(1 - \omega_r/\omega_s)$$

$$= P_g(\omega_s - \omega_r/\omega_s)$$

$$P = P_g * s$$

$$S = (N_s - N_r)/N_s$$

$$S = (1200 - 1152)/1200$$

$$S = 0.04$$

$$\text{So, } P_{r\text{loss}} = 0.04 * 75$$

$$= 3 \text{ kW}$$

$$\text{Then } P_m = P_g - P_{r\text{loss}}$$

$$= 75 - 3$$

$$70 \text{ kW}$$

**BHARTIYA SKILL DEVELOPMENT UNIVERSITY**

**School of Electrical Skills
Session 2020 -21 (Summer Semester)
B. Voc. Program, 5th Semester,
End – Semester Examination**

Course Code: ELE 1503**Time: 2 Hours****Course Name: Electrical Machines – II****Max. Marks: 50**

Instructions: Answer all questions from section A, each question carries one mark. Answer all questions from section B, each question carries four marks. Answer all questions from section C, each question carries six marks. Scientific calculator is allowed.

Section – A**10X01 = 10 Marks**

1. N_s is the synchronous speed and s the slip, then actual running speed of an induction motor will be:
(a) N_s (b) $s.N$ (c) $(1-s)N_s$ (d) $(N_s-1)s$
2. In a shaded pole motor, the shading coil usually consist of:
(a) A single turn of heavy wire which is in parallel with running winding
(b) A single turn of heavy copper wire which is short-circuited and carries only induced current
(c) A multilayer fine gauge copper wire in parallel with running winding
(d) None of the above
3. A universal motor is one which:
(a) Is available universally (b) Can be marketed internationally
(c) Can be operated either on dc or ac supply (d) Runs at dangerously high speed on no-load
4. Star-delta starting of motors is not possible in case of:
(a) single phase motors (b) variable speed motors
(c) low horse power motors (d) high speed motors
5. Which of the following methods is easily applicable to control the speed of the squirrel-cage induction motor?
(a) By changing the number of stator poles (b) Rotor rheostat control
(c) By operating two motors in cascade (d) By injecting e.m.f. in the rotor circuit
6. It is advisable to avoid line-starting of induction motor and use starter because:
(a) motor takes five to seven times its full load current
(b) it will pick-up very high speed and may go out of step
(c) it will run in reverse direction
(d) starting torque is very high
7. A shaded pole motor can be used for:
(a) Toys (b) Hair dryers (c) Circulators (d) Any of these
8. Speed of the universal motor is:
(a) Dependent on frequency of supply (b) Proportional to frequency of supply
(c) Independent of frequency of supply (d) None of these
9. The shaded pole motor is used for:
(a) High starting torque (b) Low starting torque
(c) Medium starting torque (d) Very high starting torque
10. Three-phase induction motor is mainly suitable for which of the following application:
(a) For running different machine tools where several speeds are required
(b) For running paper machine requiring exact speed control
(c) For running rolling mills needing exact speed control
(d) None of these



BHARTIYA SKILL DEVELOPMENT UNIVERSITY

Section – B

04x04 = 16 Marks

1. Prove that the slip of an induction motor is equal to one at standstill condition.
2. What do you mean by crawling of an induction motor?
3. An 8-pole, 3-phase, 60 Hz, star connected induction motor has a slip of 5%. Calculate full load speed of motor.
4. Draw and explain Inverted V-Curves of Synchronous Motor.

Section – C

04x06 = 24 Marks

1. For a 3 phase induction motor draws 80kW from the 3 phase source. Given that Synchronous Speed $N_s = 1200$ RPM, Rotor speed $N_r = 1152$ RPM, Total stator loss = 5KW. Find the Rotor output power produced by the machine.
2. A 4 pole 50Hz induction motor, Calculate the rotor frequency in following condition:
 - a. Motor is running at 500 rpm in opposite direction of field
 - b. Motor is running at 2000 rpm in same direction of field
3. With suitable example explain different modes of operation of induction motor.
4. Explain the Blocked Rotor or Short-Circuit Test of an induction motor.



BHARTIYA SKILL DEVELOPMENT UNIVERSITY
School of Electrical Skills
5th Semester, End – Semester Examination
B. Voc. Program, Summer Semester (2020-21)

Course Code: ELE 1503

Course Name: Electrical Machines – II

Time: 2 Hours

Max. Marks: 50

Instructions: Answer all questions from section A, each question carries one mark. Answer all questions from section B, each question carries four marks. Answer all questions from section C, each question carries six marks. Scientific calculator is allowed.

Section – A

10X01 = 10 Marks

1. N_s is the synchronous speed and s the slip, then actual running speed of an induction motor will be:
(a) N_s (b) $s.N$ (c) $(1-s)N_s$ (d) $(N_s-1)s$
2. In a shaded pole motor, the shading coil usually consist of:
(a) A single turn of heavy wire which is in parallel with running winding
(b) **A single turn of heavy copper wire which is short-circuited and carries only induced current**
(c) A multilayer fine gauge copper wire in parallel with running winding
(d) None of the above
3. A universal motor is one which:
(a) Is available universally (b) Can be marketed internationally
(c) **Can be operated either on dc or ac supply** (d) Runs at dangerously high speed on no-load
4. Star-delta starting of motors is not possible in case of:
(a) **single phase motors** (b) variable speed motors
(c) low horse power motors (d) high speed motors
5. Which of the following methods is easily applicable to control the speed of the squirrel-cage induction motor?
(a) **By changing the number of stator poles** (b) Rotor rheostat control
(c) By operating two motors in cascade (d) By injecting e.m.f. in the rotor circuit
6. It is advisable to avoid line-starting of induction motor and use starter because:
(a) **motor takes five to seven times its full load current**
(b) it will pick-up very high speed and may go out of step
(c) it will run in reverse direction
(d) starting torque is very high rotor runs at a speed?
7. A shaded pole motor can be used for:
(a) Toys (b) Hair dryers (c) Circulators (d) **Any of these**
8. Speed of the universal motor is:
(a) **Dependent on frequency of supply** (b) Proportional to frequency of supply
(c) Independent of frequency of supply (d) None of these
9. The shaded pole motor is used for:
(a) High starting torque (b) **Low starting torque**
(c) Medium starting torque (d) Very high starting torque
10. Three-phase induction motor is mainly suitable for which of the following application:
(a) **For running different machine tools where several speeds are required**
(b) For running paper machine requiring exact speed control
(c) For running rolling mills needing exact speed control
(d) None of these

Section – B

04x04 = 16 Marks

1. Prove that the slip of an induction motor is equal to one at standstill condition.

$$S = \frac{N_s - N_r}{N_s} \text{ rpm}$$

Where s is the slip

Notice that : if the rotor runs at synchronous speed

$$s = 0$$

if the rotor is stationary

$$s = 1$$

Slip may be expressed as a percentage by multiplying the above eq. by 100, notice that the slip is a ratio and doesn't have units

BHARTIYA SKILL DEVELOPMENT UNIVERSITY

2. What do you mean by crawling of an induction motor?
Sometimes, squirrel cage induction motors exhibits a tendency to run at very slow speeds (as low as one-seventh of their synchronous speed). This phenomenon is called as **crawling of an induction motor**. This action is due to the fact that, flux wave produced by a stator winding is not purely sine wave. Instead, it is a complex wave consisting a fundamental wave and odd harmonics like 3rd, 5th, 7th etc. The fundamental wave revolves synchronously at synchronous speed N_s whereas 3rd, 5th, 7th harmonics may rotate in forward or backward direction at $N_s/3$, $N_s/5$, $N_s/7$ speeds respectively.

3. An 8-pole, 3-phase, 60 Hz, star connected induction motor has a slip of 5%. Calculate full load speed of motor.

: In Induction Motor,
Speed $N_s = (120 * \text{frequency}) / (\text{No. of poles})$
Speed $N_s = (120 * 60) / 8 = 900 \text{ rpm}$.
So the slip $S = (N_s - N) / N_s$
 $0.05 = (900 - N) / 900$
 $N = 855 \text{ rpm}$

4. Draw and explain Inverted V-Curves of Synchronous Motor.

If the power factor is plotted against excitation for various load conditions, we obtain a set of curves known as 'Inverted V-Curves'. The inverted V-Curves of synchronous motor shows how the power factor varies with excitation. From inverted V-curves, it is observed that the power factor is lagging when the motor is under excited and leading when it is over-excited. In between, the power factor is unity.

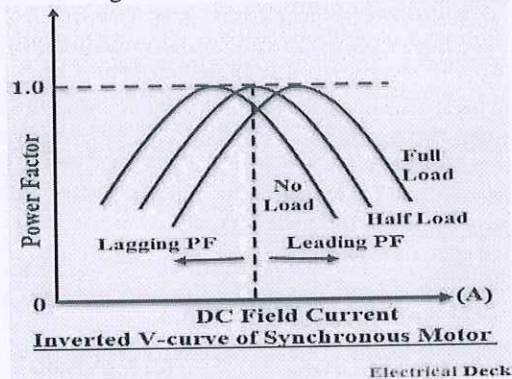

Section – C

04x06 = 24 Marks

1. For a 3 phase induction motor draws 80kW from the 3 phase source. Given that Synchronous Speed $N_s = 1200 \text{ RPM}$, Rotor speed $N_r = 1152 \text{ RPM}$, Total stator loss = 5kW. Find the Rotor output power produced by the machine.

$$P_i = 80 \text{ kW}$$

$$\text{So, } P_g = 80 - 5 = 75 \text{ kW}$$

$$P_m = P_g - P_{r\text{loss}}$$

$$P_{r\text{loss}} = P_g - P_m$$

$$P_{r\text{loss}} = T \omega_s - T \omega_r$$

$$= T(\omega_s - \omega_r)$$

$$= T \omega_s (1 - \omega_r / \omega_s)$$

$$= P_g (\omega_s - \omega_r / \omega_s)$$

$$P = P_g * s$$

$$S = (N_s - N_r) / N_s$$

$$S = (1200 - 1152) / 1200$$

$$S = 0.04$$

$$\text{So, } P_{r\text{loss}} = 0.04 * 75$$

$$= 3 \text{ kW}$$

$$\text{Then } P_m = P_g - P_{r\text{loss}}$$

$$= 75 - 3$$

$$70 \text{ kW}$$

2. A 4 pole 50Hz induction motor, Calculate the rotor frequency in following condition:
- Motor is running at 500 rpm in opposite direction of filed
 - Motor is running at 2000 rpm in same direction of filed

BHARTIYA SKILL DEVELOPMENT UNIVERSITY

- A 4 pole 50Hz IM
Calculate the rotor frequency in following condition
- Motor is running at 500 rpm in opposite direction of field

$$N_s = \frac{120f}{p} = \frac{120 \times 50}{4} = 1500 \text{ rpm}$$

$$S = \frac{N_s - N_r}{N_s}$$

Here, $N_r = -500$

$$S = \frac{1500 - (-500)}{1500} = 1.33$$

Rotor frequency $f_r = s * f_s = 1.33 * 50 = 66.5 \text{ Hz}$

- A 4 pole 50Hz IM
Calculate the rotor frequency in following condition
- Motor is running at 2000 rpm in same direction of field

$$N_s = \frac{120f}{p} = \frac{120 \times 50}{4} = 1500 \text{ rpm}$$

$$S = \frac{N_s - N_r}{N_s}$$

Here, $N_r = 2000$

$$S = \frac{1500 - (2000)}{1500} = -0.33$$

Rotor frequency $f_r = s * f_s = -0.33 * 50 = -16.66 \text{ Hz}$

3. With Suitable example explain different modes of operation of induction motor.

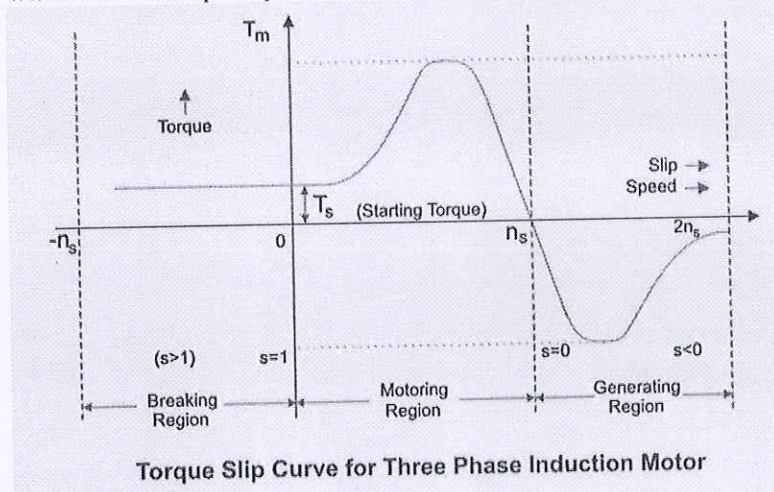

Motoring Mode

In this mode of operation, supply is given to the stator sides and the motor always rotates below the synchronous speed. The induction motor torque varies from zero to full load torque as the slip varies. The slip varies from zero to one. It is zero at no load and one at standstill. From the curve it is seen that the torque is directly proportional to the slip.

That is, more is the slip, more will be the torque produced and vice-versa. The linear relationship simplifies the calculation of motor parameter to great extent.

Generating Mode

In this mode of operation induction motor runs above the synchronous speed and it should be driven by a prime mover. The stator winding is connected to a three phase supply in which it supplies electrical energy. Actually, in this case, the torque and slip both are negative so the motor receives mechanical energy and delivers electrical energy. Induction motor is not much used as generator because it requires reactive power for its operation.

That is, reactive power should be supplied from outside and if it runs below the synchronous speed by any means, it consumes electrical energy rather than giving it at the output. So, as far as possible, induction generators are generally avoided.

Braking Mode

BHARTIYA SKILL DEVELOPMENT UNIVERSITY

In the Braking mode, the two leads or the polarity of the supply voltage is changed so that the motor starts to rotate in the reverse direction and as a result the motor stops. This method of braking is known as plugging. This method is used when it is required to stop the motor within a very short period of time. The kinetic energy stored in the revolving load is dissipated as heat. Also, motor is still receiving power from the stator which is also dissipated as heat. So as a result of which motor develops enormous heat energy. For this stator is disconnected from the supply before motor enters the braking mode.

4. Explain the Blocked Rotor or Short-Circuit Test of an induction motor.

- The blocked rotor test of an induction motor is same as the short-circuit test of a transformer. In this test, the shaft of the motor is connected so that it cannot move and rotor winding is short-circuited. In a slip-ring motor, the rotor winding is short-circuited through slip-rings and in cage motors, the rotor bars are permanently short-circuited. This test is also called the locked-Rotor test.
- When a reduced voltage at the reduced frequency is applied to the stator through a 3-phase auto-transformer so that full-load current flows in the stator, the following three readings are obtained.

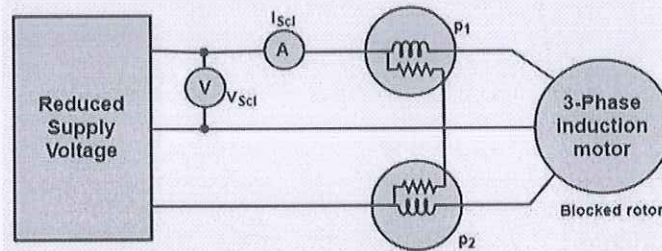

1) The total power input on short-circuits

$$P_{sc} = \text{algebraic sum of the two wattmeter readings.}$$

2) Reading of ammeter

$$I_{sc1} = \text{line current on short circuit.}$$

3) Reading of voltmeter

$$V_{sc1} = \text{Line voltage on the short circuit}$$

$$\therefore P_{sc} = \sqrt{3} V_{sc1} \cos \phi_{sc} I_{sc1}$$

Where $\cos \phi_c = \text{Power factor on short circuit}$

$$R_{e1} = \frac{P_{scp}}{I_{scp}^2}$$

Equivalent impedance of the motor referred to the stator Z_{e1} is,

$$Z_{e1} = \frac{V_{scp}}{I_{scp}}$$

Equivalent reactance of the motor referred to stator

$$X_{e1} = \sqrt{Z_{e1}^2 - R_{e1}^2}$$



School of Electrical Skills
Session: 2020-21 (Summer Semester)
B. Voc. Program, 5th Semester,
End -Sem. Examination

Course Code: ELE1505

Time: 2 Hour

Course Name: Advance Automation & Control

Max. Marks: 50

Instructions: Answer all questions from section A, each question carries one mark. Answer all questions from section B, each question carries four marks. Answer all questions from section C, each question carries six marks. Scientific calculator is allowed.

Section – A

10X01 = 10 Marks

1. Full form of IED is: -
(a) Intelligent energy drive
(b) Intelligent Electronic Devices
(c) Instrument Electronic Devices
(d) None of these
2. Integral controller is also known as: -
(a) Reset controller
(b) Rate controller
(c) Both (a) and (b)
(d) None of these
3. Full form of PD controller is: -
(a) Proportional and Derivative
(b) Preset and Derivative
(c) Program and Derivative
(d) None of these
4. SCADA systems were first used in: -
(a) 1968
(b) 1960
(c) 1965
(d) None of these
5. Third Generation SCADA system is: -
(a) Monolithic SCADA systems
(b) Distributed SCADA systems
(c) Networked SCADA systems
(d) None of these
6. A set amount of each of the inputs to the process is received in a grouped form in: -
(a) Continuous process
(b) Batch process
(c) Individual control
(d) Centralized Control
7. Full form of SMPS is: -
(a) Switch Mode Power Supply
(b) Starter Mode Power Supply
(c) Standard Mode Power Supply
(d) None of these
8. The time required to make a single scan of PLC program: -
(a) 1 ms to 150 ms
(b) 1 ms to 20 ms
(c) 1 ms to 100 ms
(d) None of these
9. The _____ mode is used to operate or monitor the user program without energizing any outputs.
(a) Run mode
(b) Program mode
(c) Test mode
(d) None of these
10. Opcodes are used in _____ Logic.
(a) Statement logic
(b) Boolean algebra
(c) Flowchart
(d) Mnemonics Logic

Sidharth
Set - A



Section – B

04X04 = 16 Marks

1. Explain the following: -
 - (a) Manual Controlling
 - (b) Pneumatic Controlling
 - (c) Hard wired Controlling
 - (d) Logic gate Controlling
2. Explain the Rack Installation.
3. What are the applications of Human Machine Interface?
4. Explain Sinking and Sourcing types of input with Diagram.

Section – C

04X06 = 24 Marks

1. Explain the advantages of PLC in detail.
2. Explain Fault diagnosis technique and Troubleshooting.
3. Explain Ladder Logic Basic Gate functions with truth table and Ladder Logic Diagram.
4. Explain the Scan Cycle of PLC program with diagram.



BHARTIYA SKILL DEVELOPMENT UNIVERSITY

School of Electrical Skills

Session: 2020-21 (Summer Semester)

B. Voc. Program, 5th Semester,

End -Sem. Examination

Course Code: ELE1505

Time: 2 Hour

Course Name: Advance Automation & Control

Max. Marks: 50

ANSWER-SHEET

Section – A

1. A set amount of each of the inputs to the process is received in a grouped form: -
 - (a) Batch process
2. Full form of SMPS is: -
 - (a) Switch Mode Power Supply
3. The time required to make a single scan of PLC program: -
 - (b) 1 ms to 20 ms
4. The _____ mode is used to operate or monitor the user program without energizing any outputs.
 - (c) Test mode
5. Opcodes are used in _____ Logic.
 - (d) Mnemonics Logic
6. The _____ are drawn as horizontal lines and connect the rails to the logic expressions.
 - (a) Rungs
7. Derivative controller is also known as: -
 - (b) Rate controller
8. Full form of PID controller is: -
 - (a) Proportional, Derivative and Integral
9. Full form of SCADA is: -
 - (a) Supervisory Control and Data Acquisition
10. Forward accelerating quadrant with positive speed and positive torque is: -
 - (a) Quadrant I

Section – B

1. **(a) Manual Controlling:** In manual control system, the process operator observes the process condition and controls the system by doing manual adjustments. Heron of Alexandria, a Greek mathematician, invented the first automatic door, which could open the gates to the city using a series of ropes and pulleys.
(b) Pneumatic Controlling: A pneumatic system is a collection of interconnected components using compressed air to do work for automated equipment. In this case the use of a gaseous media under pressure to generate, transmit and control power; typically using compressed gas such as air at a pressure of 60 to 120 pounds per square inch (PSI). Hydraulics is another form of fluid power, which uses a liquid media such as oil but at a much higher pressure with a typical range of 800 to 5000 PSI. EX. Hydraulic gates.



BHARTIYA SKILL DEVELOPMENT UNIVERSITY

(c) Hard wire controlling: Hard-wired means the electrical cable is physically connected or wired into the household wiring. Ex. Hard wired counter, timer etc.

(d) Electric logic gate controlling: A logic gate is an idealized or physical device implementing a Boolean function that, performs a logical operation on one or more binary inputs and produces a single binary output.

2. Rack Installation:

- The rack mounting type of PLC is similar to the modular concept, but is implemented differently. Whereas each module in a modular PLC connects to the base unit directly, a rack mounting PLC keeps each module separate.
- All extra modules are connected through a network, and modules are held in organized racks. This approach allows for larger systems to be built without becoming overly cluttered and complicated. Modules are well organized on the rack and can be removed and reinserted as needed.
- The commercial unit is an industry-standard example of the rack mounting PLC type. There are essentially no limits on the number of modules that can be added to this system, each mounted on a standard rack chassis. This setup allows large, scalable automation solutions to be built and is common in factories.

3. Applications of HMI

- a. The HMI is used throughout various industries including manufacturing plants, vending machines, food and beverage, pharmaceuticals, and utilities etc.
- b. HMIs along with PLCs are typically the backbone of the production line in these industries. The integration of the HMI into manufacturing has vastly improved operations. The HMI allows for supervisory control and data acquisition in the entire system, so parameter changes are feasible as the operator's choosing.
- c. For example, in metals manufacturing, an HMI might control how metal is cut and folded, and how fast to do so. HMIs are used in bottling processes to control all aspects of the manufacturing line, such as speed, efficiency, error detection and error correction. Utility companies may use HMIs to monitor water distribution and waste water treatment.

4.



BHARTIYA SKILL DEVELOPMENT UNIVERSITY

- **Sinking Input:** The input energizes when high-level voltage is applied to the input terminal (active high). Connect the power supply VDC (-) to the input group's COM terminal.

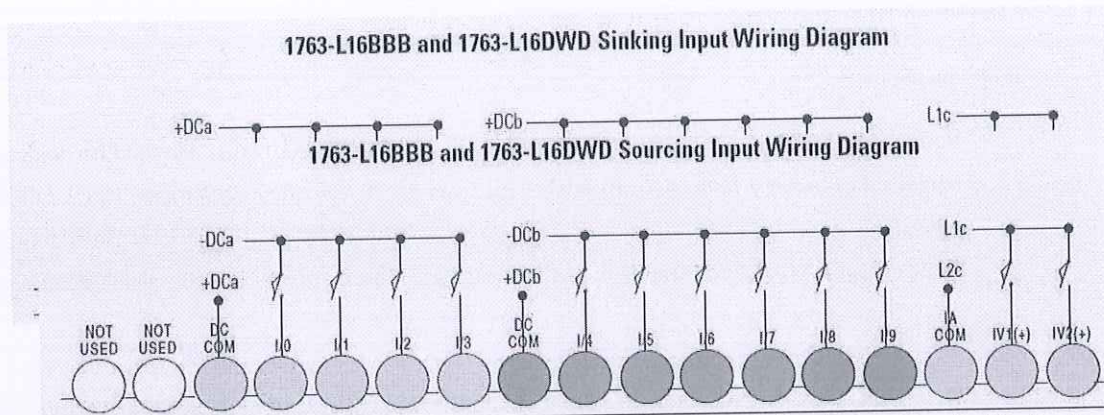

Sourcing Input: The input energizes when low-level voltage is applied to the input terminal (active low). Connect the power supply VDC (+) to the input group's COM terminal.

Section – C

1. Advantages of PLC:

- 1) **Increased Reliability:** Once a program has been written and tested, it can be easily downloaded to PLC. Since all the logic is contained in the PLC's memory there is no change of making a logic wiring error.
- 2) **More flexibility:** It is easier to create and change a program in a PLC than to wire and rewire the circuit. With a PLC the relationship between the input and output are determined by the user program instead of manner in which they are interconnected.
- 3) **Lower cost:** PLC were originally designed to replace relay control logic, and the cost saving have so significant that relay control is becoming obsolete except for power applications.
- 4) **Communication capability:** A PLC can communicate with other controllers such as Human machine Interface, Supervision control, Data gathering, Monitoring devices and process parameters.
- 5) **Faster Response time:** PLCs are designed for high-speed and real-time applications. The PLC operates in real time, which means that an event taking place in the field will result in the execution of an operation or output. Machines that process thousands of items per second and objects that spend only a fraction of second in front of a sensor require the PLC's quick-response capability.
- 6) **Easier to troubleshoot:** PLC's have resident Diagnostics and override functions that allow user to easily trace and correct software and hardware problems. To find and fix problems user can display the control program on a monitor and watch it in real time as it executes.



2. Fault diagnosis technique and Troubleshooting

The 5 Step Troubleshooting Approach consists of the following:

1. Preparation

- Before you begin to troubleshoot any piece of equipment, you must be familiar with your organization's safety rules and procedures for working on electrical equipment. These rules and procedures govern the methods you can use to troubleshoot electrical equipment (including your lockout/ tagout procedures, testing procedures etc.) and must be followed while troubleshooting.

2. Observation

- Most faults provide obvious clues as to their cause. Through careful observation and a little bit of reasoning, most faults can be identified as to the actual component with very little testing.

3. Define Problem Area

- Starting with the whole circuit as the problem area, take each noted observation and ask yourself "what does this tell me about the circuit operation?" If an observation indicates that a section of the circuit appears to be operating properly, you can then eliminate it from the problem area. As you eliminate each part of the circuit from the problem area, make sure to identify them on your schematic. This will help you keep track of all your information.

4. Identify Possible Causes

- Once the problem area(s) have been defined, it is necessary to identify all the possible causes of the malfunction. This typically involves every component in the problem area(s).

5. Determine Most Probable Cause

- Once the list of possible causes has been made, it is then necessary to prioritize each item as to the probability of it being the cause of the malfunction.

6. Test and Repair

- Testing electrical equipment can be hazardous. The electrical energy contained in many circuits can be enough to injure or kill. Make sure you follow all your companies safety precautions, rules and procedures while troubleshooting.

3. Ladder Logic Basic Gate functions

(1) Ladder Logic NOT Function



BHARTIYA SKILL DEVELOPMENT UNIVERSITY

- The result of the NOT function is basically the opposite state of an event that occurs.
- So if PLC input A is FALSE the result will be TRUE. And vice versa when PLC input A is TRUE the result will be FALSE.
- The NOT Function is sometimes referred to as reverse logic. Check out the truth table below....
- If we translate a NOT function into a ladder logic diagram we express, it symbolically in the form of

A	NOT A
FALSE	TRUE
TRUE	FALSE

a normally closed (NC) contact.

	A	NOT A
FALSE		
TRUE		

(2) Ladder Logic AND Function

- The AND function examines multiple PLC inputs and has one resulting output.
- If we translate an AND function into a ladder diagram we can express, it symbolically in the form of two normally open (NO) contacts (PLC inputs A and B) and a relay coil (PLC output Y).
- They are all connected in line, just like a series connection in an electric circuit.
- Check out the truth table -

IF AND THEN

	INPUTS		OUTPUT
	A	B	Y
A= FALSE B= FALSE Y= FALSE			
A= FALSE B= TRUE Y= FALSE			
A= TRUE B= FALSE Y= FALSE			
A= TRUE B= TRUE Y= TRUE			

(3) Ladder Logic OR Function

- The OR function examines multiple PLC inputs and has one resulting output.
- If we translate an OR function into a ladder diagram we can express it symbolically in the form of two normally open (NO) contacts (PLC inputs A and B) and a relay coil (PLC output Y).



BHARTIYA SKILL DEVELOPMENT UNIVERSITY

- The inputs are placed in the rung in what is known as a branch. This is the equivalent of a parallel connection in an electric circuit.
- Check out the truth table-

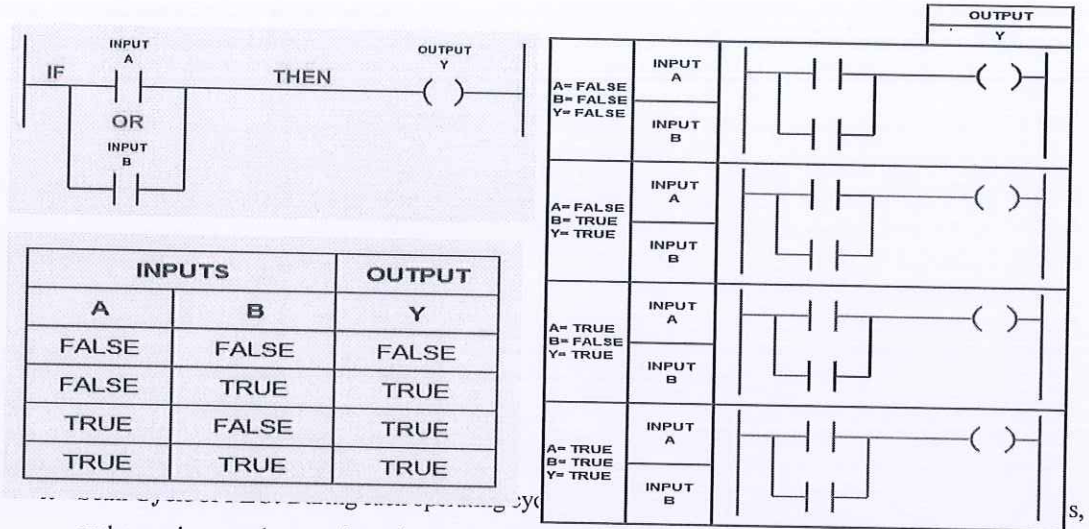

and energizes or de-energizes the output according to the user program. This process is known as program scan cycle. Fig. illustrates a single PLC operating cycle consisting of the input scan, program scan, output scan and house-keeping duties. It constantly repeats this cycle as long as the PLC is in the RUN mode.

“The scan is normally a continuous and sequential process of reading the status of inputs, evaluating the control logic, and updating the output

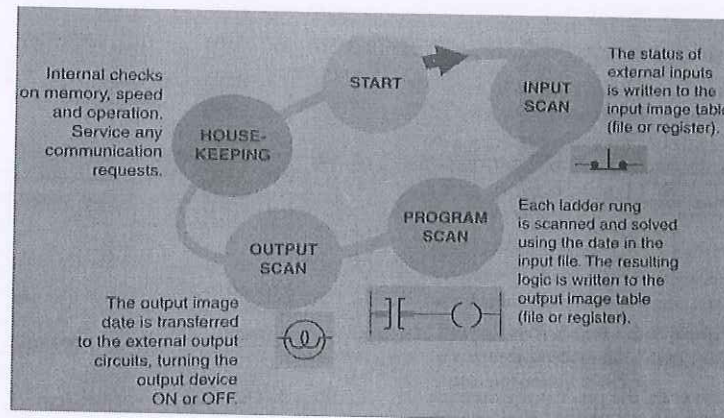



BHARTIYA SKILL DEVELOPMENT UNIVERSITY

School of Electrical Skills
Session: 2020-21 (Summer Semester)
B. Voc. Program, 5th Semester,
End -Sem. Examination

Course Code: ELE1505

Course Name: Advance Automation & Control

Time: 2 Hours

Max. Marks: 50

Instructions: Answer all questions from section A, each question carries one mark. Answer all questions from section B, each question carries four marks. Answer all questions from section C, each question carries six marks. Scientific calculator is allowed.

Section – A

10X01 = 10 Marks

1. The _____ are drawn as horizontal lines and connect the rails to the logic expressions.
(a) Rungs (b) Logic Expressions
(c) Comments (d) Address Notation
2. Derivative controller is also known as: -
(a) Reset controller (b) Rate controller
(c) Both (a) and (b) (d) None of these
3. Full form of PID controller is: -
(a) Proportional, Integral and Derivative (b) Preset, Integral and Derivative
(c) Program, Integral and Derivative (d) None of these
4. Full form of SCADA is: -
(a) Supervisory Control and Data Acquisition
(b) Super Central and Data Acquisition
(c) Super Control and Device Acquisition
(d) None of these
5. Forward accelerating quadrant with positive speed and torque is: -
(a) Quadrant I (b) Quadrant III
(c) Quadrant II (d) Quadrant IV
6. The father of PLC is: -
(a) Aristotle (b) Richard E. "Dick" Morley
(c) Michael Faraday (d) Archimedes
7. The function of Relay is: --
(a) Programming (b) Convert 230V AC to 24V DC
(c) Protection (d) None of these
8. Full form of the HMI is: -
(a) Human Machine Instrument (b) Human Machine Interface
(c) Human Motor Interface (d) None of these
9. Numbers of Contactors required to make star-delta starter: -
(a) One (b) Two
(c) Three (d) Four
10. Full form of the VFD is: -
(a) Variable Frequency Device (b) Variable Frequency Drive
(c) Voltage Frequency Device (d) All of these



Section – B

04X04 = 16 Marks

1. What is Distributive control system? Explain with diagram.
2. Explain the electrical maintenance of PLC system.
3. Explain the Human Machine Interface.
4. Give the comparison between relay logic controlling and PLC controlling.

Section – C

04X06 = 24 Marks

1. Differentiate between PLC and computer in Software and hardware.
2. Explain the Modes of operation of PLC.
3. Explain the types of PLC programming.
4. Explain the applications of SCADA in
 - (a) Manufacturing Industries
 - (b) Waste Water Treatment and Distribution Plants
 - (c) SCADA in Power System



Answer Key ELE 1505 (Set – B)
BHARTIYA SKILL DEVELOPMENT UNIVERSITY

School of Electrical Skills
Session: 2020-21 (Summer Semester)
B. Voc. Program, 5th Semester,
End -Sem. Examination

Course Code: ELE1505

Course Name: Advance Automation & Control

Time: 2 Hour

Max. Marks: 50

ANSWER-SHEET

Section – A

1. The father of PLC is: -
(b) Richard E. "Dick" Morley
2. The function of Relay is: --
(c) Protection
3. Full form of the HMI is: -
(b) Human Machine Interface
4. Numbers of Contactors required to make star-delta starter: -
(a) Three
5. Full form of the VFD is: -
(b) Variable Frequency Drive
6. Full form of IED is: -
(b) Intelligent Electronic Devices
7. Integral controller is also known as: -
(a) Reset controller
8. Full form of PD controller is: -
(a) Proportional and Derivative
9. SCADA systems were first used in: -
(b) 1960
10. Third Generation SCADA system is: -
(b) Networked SCADA systems

Section – B

1. **Distributive control system(DCS):** This is a network based system. Distributive control involves two or more PLCs communicating with each other to accomplish the complete control task. Each PLC controls different processes locally and the PLC are constantly exchanging information through communication link.

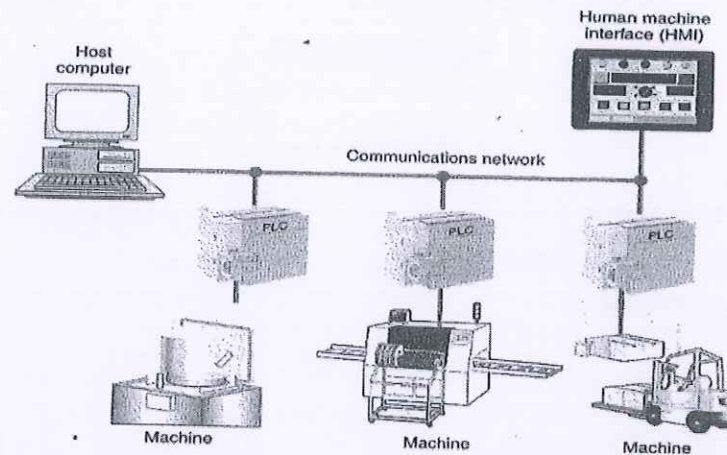

2. Electrical maintenance

All electrical systems require periodic maintenance in addition to non-scheduled maintenance caused by unpredictable events such as storms, accidents, and equipment failure. Certain maintenance activities are common to all systems, regardless of type. These activities should always be performed on the cycle applicable for the system. These activities are defined as follows:

- Clean conductors, terminals, and connectors of all corrosion. Tighten terminals and connectors including breaker, transformer, and contactor connectors.
 - Check the equipment grounding system including conduit end bushing connections, bonds, equipment grounding conductors, enclosure grounding connections, and pole grounding connections.
 - Check the grounding electrode, grounding electrode conductor, and associated connections.
 - Check conductor insulation for damage, and repair if necessary.
 - Replace deteriorated or missing conductor and terminal identification markings.
3. **Human Machine Interface (HMI)**
 - PLCs are built to input various signal types (discrete, analog), execute control algorithms on those signals, and then output signals in response to control processes. By itself, a PLC generally lacks the capability of displaying those signal values and algorithm variables to human operators.

- In order for operators to monitor and adjust parameters inside the PLC's memory, we need a different sort of interface allowing certain variables to be read and written without compromising the integrity of the PLC by exposing too much information or allowing any unqualified person to alter the program itself.
- One solution to this problem is a dedicated computer display programmed to provide selective access to certain variable's in the PLC's memory, generally referred to as Human-Machine Interface, or HMI.

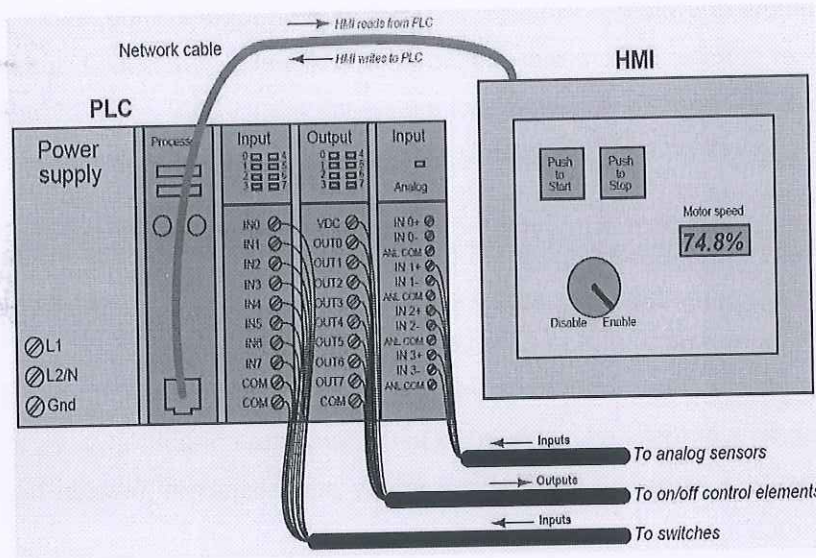

4. Most industrial HMI panels come equipped with touch-sensitive screens, allowing

Relay Logic	PLC
Hardwired logic Using relay switches	Software logic Using CPU and memory
Difficult to upgrade and maintain	Modular, easier to program
Limited in terms of speed size, complexity, and reliability	Superior in these terms
Dated technology	Current technology

operators to press their fingertips on displayed objects to change screens, view details on portions of the process, etc.



Section – C

1. Comparison between PLC and Computer:

The architecture of a **PLC** is basically the same as that of a personal computer. A personal computer (PC) can be made to operate as a programmable logic controller if you provide some way for the computer to receive information from devices such as pushbuttons or switches. We also need a program to process the inputs and decide the means of turning load devices off and on. However, PLC is a specially designed computer to operate in an industrial environment. The main difference between computer and PLC are list below on two sections hardware and software.

Hardware:

- The PLC comes with its program language built into its memory and has no the permanently attached keyboard CD drive or monitor. While computers are permanently attached to a keyboard and other hardware.
- Computers are complex computing machines capable of executing several programs or tasks simultaneously and in any order. Most PLCs, on the other hand, execute a single program in an orderly and sequential fashion from first to last instruction.

Software:

- PLC software that allows the user to monitor and control the process is also called a human machine interface (HMI). It enables the user to view a process—or a graphical representation of a process—on a monitor, determine how the system is running, trend values, and receive alarm condition.
- Programmable automation controllers (PAC) combine PLC ruggedness with PC functionality. Using PACs, you can build advanced systems incorporating software capabilities such as advanced control, communication, data logging, and signal processing with rugged hardware performing logic, motion, process control, and vision.

2. Mode of operations of PLC

Some common operating modes of PLC are explained as follows:

1. Program Mode: The program mode is used to enter a new program, edit or update an existing program, upload files, download files, document (print out) programs, or change any software configuration file in the program. When the PLC is switched into



the program mode, all output are forced off regardless of their rung logic status, and the ladder I/O scan sequence is halted.

2. Run Mode: The Run Mode is used to execute the user program. Input devices are monitored and output devices are energized accordingly. After all instructions have been entered in a new program or all changes made to existing program, the processor is put in the run mode.

3. Test Mode: The test mode is used to operate or monitor the user program without energizing any outputs. The processor still reads inputs, executes the ladder program, and update the output status table files, but without energizing the output circuit. This feature is often used after developing or editing a program to test the program execution before allowing the PLC to operate real-world outputs.

4. Remote Mode: In the Run position, all logic is solved and I/O is enabled. In the program position, all logic solving is stopped and the I/O is disabled. The remote position allows the PLC to be remotely changed between program and run mode by personal computer connected to the PLC processor. The remote mode may be beneficial when the controller is in a location that is not easily accessible.

3. Types of PLC Programming:

The basic functioning of the PLC relies on the control logic or the programming technique used. Programming can be done using flowcharts or using ladder logic or using statement logics or mnemonics.

- **Flowchart:** A flowchart is the symbolic representation of the instructions. It is the most basic and simplest form of control logic which involves only logic decisions.
- **Boolean algebra:** Boolean algebra usually involves logic operations like AND, OR, NOT, NAND and NOR. The different symbols are:

(+) Or operator (.) AND operator (!)NOT operator.

- **Statement logic:** The instructions in simple statement forms can be written as:

"IF Input1 AND Input2 is TRUE Then SET Output1 ELSE SET Output2"

- **Mnemonics Logic:** Mnemonics are instructions written in symbolic form. They are also known as Opcode and are used in handheld programming devices. Different Symbols are as given below:

Ldi – Load Inverse

OR-Or logic

Ld- Load

ANI – NAND logic



AND- And logic

ORI- NOR logic

Out – Output

4. Applications of SCADA system:

(1) SCADA In Manufacturing Industries

In manufacturing industries the regular processes like running the production systems to meet the productivity targets, checking the number of units produced and counting the completed stages of operations along with temperatures at various stages of the manufacturing process, and so on, are taken care by using the SCADA application.

(2) SCADA Application in Waste Water Treatment and Distribution Plants

Wastewater treatment plants are of different types such as surface-water treatment and a well water treatment system in which many control systems and automation processes are involved in water treatment and distribution systems. SCADA systems are used for controlling the automatic operations of the equipment used like backwashing the filters based on the hours of working or amount of water flow through the filters.

(3) SCADA in Power System

- Power system can be defined as constituent of power generation, transmission and distribution. All these sectors are needed to be monitored regularly for improving the system efficiency.
- Thus, the application of SCADA in power system improves the overall efficiency of the system by providing the supervision and control over the generation, transmission and distribution systems.
- SCADA in the power system network increases the system's reliability and stability for integrated grid operation.



School of Electrical Skills

Session: 2020-21 (Summer Semester)

B. Voc. Program, III/V Semester,

End-Sem. Examination

Course Code: ELE 1121

Time: 2 Hours

Course Name: Repairing and Servicing of Electrical Appliances

Max. Marks: 50

Instruction: Answer all questions from section A, each question carries one mark. Answer all questions from section B, each question carries four marks. Answer all questions from section C, each question carries six marks. Scientific calculator is allowed.

Section – A

10X01 = 10 Marks

1. On Working Site, white helmet is for:
(a) Engineer (b) Welder
(c) Electrician (d) Safety Officer
2. What is the full form of SPD?
(a) Surge protection device (b) Shutdown protection device
(c) Shock protection device (d) Surge prevention device
3. When two batteries are connected in parallel, it should be ensured that:
(a) They have same emf (b) They have same make
(c) They have same ampere hour capacity (d) They have identical internal resistance
4. Tool which we use for judge the quality and reliability of our work?
(a) Inventory list (b) Check-list
(c) Stock-register (d) Work-permit
5. In following, which is not the part of fire triangle?
(a) Heat (b) Fuel (c) CO₂ (d) O₂
6. Which of the following quantities remain the same in all parts of a series circuit?
(a) Voltage (b) Current
(c) Power (d) Resistance
7. The insulation on a current carrying conductor is provided:
(a) To prevent leakage of current (b) To prevent a shock
(c) Both of the above (d) None of the above
8. Which of the following motors is used in ceiling fan?
(a) Universal motor (b) Synchronous motor
(c) Series motor (d) Induction motor
9. In the case of direct current:
(a) Magnitude and direction of current remains constant
(b) Magnitude and direction of current changes with time
(c) Magnitude of current changes with time
(d) Magnitude of current remains constant
10. You have to replace 1500-ohm resistor in radio. You do not have 1500-ohm resistor but have several 1000 ohm resistors. Which resistor combination you would connect?
(a) two in parallel (b) two in parallel and one in series
(c) three in parallel (d) three in series

1. Write short note on selection of proper breaker size for electrical circuit.
2. Write short note on testing of motor through multi-meter.
3. Differentiate between ammeter and voltmeter.
4. The diagram below shows a circuit with one battery and 10 resistors; 5 on the left and 5 on the right. Determine equivalent resistor.

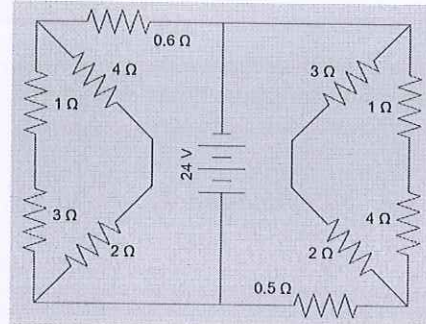

Section – C

1. Explain the fire triangle also explain the classification chart of different types of fire extinguishers.
2. Explain the importance of earthing in electrical system also explain the procedure of measuring the earth resistance.
3. Explain the operation of electric water heater with diagram.
4. What are the possible reasons for non-working of ceiling fan and their solutions?



Answer Key Set – A
Course Code: ELE 1121,
Course Name: Repairing and Servicing of Electrical Appliances
School of Electrical Skills, Session: 2020-21 (Summer Semester)
B. Voc. Program, III/V Semester, End-Sem. Examination

Section – A

1. (a) Engineer
2. (a) Surge protection device
3. (a) They have same emf
4. (b) Check-list
5. (c) CO₂
6. (b) Current
7. (c) Both of the above
8. (d) Induction motor
9. (a) Magnitude and direction of current remains constant
10. (b) two in parallel and one in series

Section – B

1. For find the Proper Size of circuit breaker we follow the following steps:
 - Calculate the total connected load of our building.
 - Find the running time of different loads and calculate the maximum running load of a particular time of the day. Mostly we take 40 to 70 percent of connected load as a maximum running load at a time.
 - Through Maximum running load, Get the maximum current which passes through the electrical circuit.
 - According to maximum current, choose what kind of breaker we need for our system. Ex. For 0 to 63 Amp current we choose MCB, for 63 to 630 Amp we choose MCCB.
 - After deciding our breaker type take the nearest market available size of breaker for our circuit. Ex. Available size of MCB is 1Amp, 6Amp, 16Amp, 20Amp, 25Amp etc. so if our maximum current is 22Amp we choose 25Amp MCB for our circuit.
2. For the three-phase motor, do the following:
 - (a) Check the appearance of the motor. Check for burnt, damage to body or cooling fan or shaft.
 - (b) Manually rotate motor shaft to examine bearing condition. Look out for smooth and free shaft rotation. If shaft rotation is free and smooth, bearing is possibly in good condition, otherwise consider replacing, repair or carry out further diagnosis.
 - (c) As with all testing and inspections, the motor name plate provides valuable information that will help to ascertain the true health of the motor. Examine the name plate thoroughly and compare values of running amps test (see below) with name plate value

Earth Continuity and Resistance Test

With a multimeter, measure the resistance between motor frame (body) and earth. A good motor should read less than 0.5 ohms. Any value greater 0.5 ohms indicate trouble with the motor. Further troubleshooting maybe required

Power Supply Test

For three phase motors, the expected voltage for a 230/400V system is 230V phase to neutral and 400V between each of the three phase supply lines. Check that the correct voltage is applied to the motor using a multimeter. Ensure the terminal for power supply is in good condition. Check the connection bar for terminal (U, V, and W). For three phase motors, connection type is either Star (Y) or Delta

AC Motor Winding Continuity Test

Using a multimeter, check the continuity of motor winding from phase to phase (U to V, V to W , W to U).Each phase to phase must have a continuity if winding is OK. If any particular phase fails the continuity test, your motor is probably burnt.



Answer Key Set – A
Course Code: ELE 1121,
Course Name: Repairing and Servicing of Electrical Appliances
School of Electrical Skills, Session: 2020-21 (Summer Semester)
B. Voc. Program, III/V Semester, End-Sem. Examination

Please see how to identify three phase windings for proper winding identification. U, V, W is a European winding designation.

AC Motor Winding Resistance Test

Check the motor winding resistance or ohms reading using a multimeter or ohmmeter for phase to phase terminal (U to V, V to W ,W to U).The ohms reading for each winding must be the same (or nearly the same). Remember that the three phases have identical windings with same resistance value.

3.

Basis For Comparison	Ammeter	Voltmeter
Definition	The instruments used for measuring the current.	It measures the voltage between any two points of the circuit.
Symbolic Representation		
Resistance	Low	High
Connection	It is connected in series with the circuit.	It is connected in parallel with the circuit.
Accuracy	More	Less
Changing of Range	Not possible	Possible

4. Let's begin the process by combining resistors. There are four series pairs in this circuit.

$$R_s = 3 \Omega + 1 \Omega$$

$$R_s = 4 \Omega$$

$$R_s = 4 \Omega + 2 \Omega$$

$$R_s = 6 \Omega$$

left

$$R_s = 2 \Omega + 3 \Omega$$

$$R_s = 5 \Omega$$

$$R_s = 1 \Omega + 4 \Omega$$

$$R_s = 5 \Omega$$

right

These pairs form two parallel circuits, one on the left and one on the right.

$$R_p = \frac{1}{\frac{1}{5 \Omega} + \frac{1}{5 \Omega}}$$

$$R_p = \frac{1}{\frac{2}{5 \Omega}}$$

$$R_p = \frac{5 \Omega}{2} = 2.5 \Omega$$

right

$$R_p = \frac{1}{\frac{1}{4 \Omega} + \frac{1}{6 \Omega}}$$

$$R_p = \frac{1}{\frac{5}{12 \Omega}}$$

$$R_p = \frac{12 \Omega}{5} = 2.4 \Omega$$

Each gang of four

resistors is in series with another.

$$R_s = 2.4 \Omega + 0.6 \Omega$$

$$R_s = 3 \Omega$$

left

$$R_s = 2.5 \Omega + 0.5 \Omega$$

$$R_s = 3 \Omega$$

right

The left
the battery.





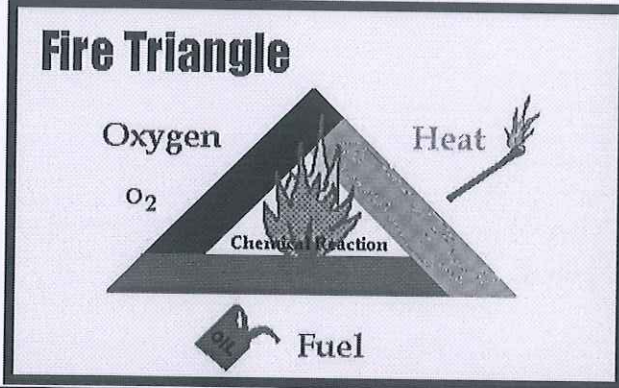

and right halves of the circuit are parallel to each other and to

$$R_p = \frac{1}{\frac{1}{3\Omega} + \frac{1}{3\Omega}} = 1.5\Omega$$

Section – C

1.



CLASS	A	B	B	C	D	K
PICTURE SYMBOL						
TYPE	Common Combustibles Solids (wood, paper, cloth, etc.)	Flammable liquids Gasoline and solvents	Flammable gases Propane	Live electrical equipment Computers, fax machines	Combustible Metals Magnesium, Lithium, Titanium	Cooking Media Cooking oils and fats
Water	✓ Yes	✗ No	✗ No	✗ No	✗ No	✗ No
Foam	✓ Yes	✓ Yes	✗ No	✗ No	✗ No	✓ Yes <small>(ABF Foam Only)</small>
Dry Powder	✓ Yes	✓ Yes	✓ Yes	✓ Yes	✗ No	✗ No
M28/L2	✗ No	✗ No	✗ No	✗ No	✓ Yes	✗ No
Carbon Dioxide CO2	✗ No	✓ Yes	✗ No	✓ Yes	✗ No	✗ No
Wet Chemical	✓ Yes	✗ No	✗ No	✗ No	✗ No	✓ Yes

2. Earthing is an important component of electrical systems because of the following reasons:

- To provide earth connections for the neutral points of transformer, capacitor banks, generators, etc. It provides path for neutral currents of three phase AC system and thereby ensure stable neutral point.
- In cases of surges in the voltage, high voltages can pass through the electricity circuit. These kinds of overload can lead to damaging of devices and danger to human life. When earthing is installed with the electrical installations, the current is routed through a different path and does not affect the electrical system.

- To ensure that overhead shielding wires of transmission lines/ outdoor yards are securely earthed so that the overhead electrical equipment's, busbars are protected from direct lightning strikes.
- It prevents damage to electrical appliances and devices by preventing excessive current from running through the circuit.
- It prevents the risk of fire that could otherwise be caused by current leakage.
- It keeps people safe by preventing electric shocks.

Measuring the Earthing Resistance:

Earth Tester: The instrument used for measuring the resistance of the earth/soil is known as earth tester also called a grounding tester. It is used for sizing and projecting grounding grids.

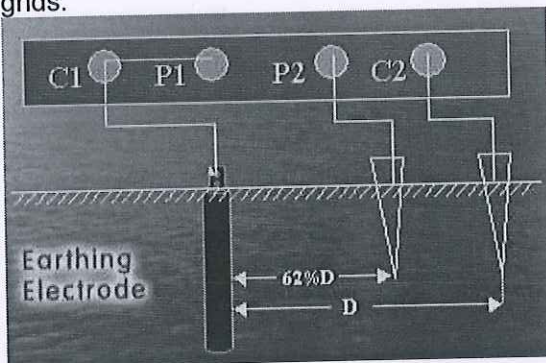

Earth Resistance check by Earth Tester

C1 & C2 = Current terminal of earth tester.

P1 & P2 = Potential Terminals of earth tester.

- The distance of current spike from earth electrode $D = 60$ ft.
- Then distance of potential spike would be 62% of $D = 0.62D$ i.e. $0.62 \times 60 = 37$ ft.
- In this method earth tester terminal C1 and P1 are shorted to each other and connected to the earth electrode (pipe) under test. Terminals P2 and C2 are connected to the two separate spikes driven in earth. These two spikes are kept in same line at the distance of specified length due to which there will not be mutual interference in the field of individual spikes.
- when we rotate generator handle with specific speed, we get directly earth resistance on meter scale.

3.

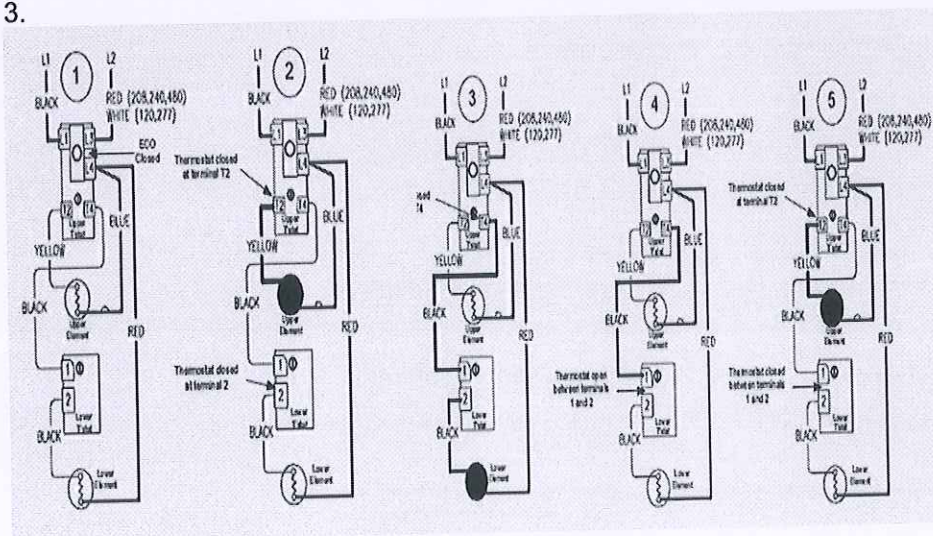



Answer Key Set – A
Course Code: ELE 1121,

Course Name: Repairing and Servicing of Electrical Appliances
School of Electrical Skills, Session: 2020-21 (Summer Semester)
B. Voc. Program, III/V Semester, End-Sem. Examination

- 1 Line voltage is applied across terminals L1 & L3 of the upper thermostat. ECO is closed, so there is voltage at terminal L4 and to one side of the upper and lower elements.
- 2 Tank is cold therefore both thermostats are closed at terminal T2 & 2 (calling for heat). The circuit is complete through the upper thermostat only, allowing current to flow through upper element.
- 3 When upper thermostat is satisfied, it opens at terminal T2 interrupting current flow through upper element, and closes at terminal T4 allowing voltage to pass to terminal 1 of lower thermostat. This completes the circuit through the lower thermostat and allows current flow through lower element.
- 4 When the lower thermostat is satisfied, it opens at terminal 2 interrupting current flow through lower element. The system is now in stand-by mode waiting for the next call for heat
- 5 The lower thermostat/element combination will generally cycle on and off more often than the upper. In some cases, such as a cold tank or in high demand periods, the upper thermostat will call for heat (opening at terminal T4 and closing at terminal T2) prior to the lower thermostat being satisfied. This will interrupt current flow through the lower thermostat and element and allow current to flow through the upper element only. When the upper thermostat is satisfied, it resumes operation as described in sequence #3 above.

4.

5.1	Fan running the wrong way.	Incorrect wiring.	To reverse the rotation of a three-phase motor interchange any two supply leads. To reverse the rotation of a single-phase motor interchange leads on the start winding. Refer to the directions in the motor junction box. This note applies to single-speed motors only. For 2-speed motors refer to the supplier.
5.2	Fan won't run	Low applied voltage Supply failure Open in winding. Condenser open or short. Open in regulator resistor/switch.	Check the voltage and adjust if possible. Check the supply points at switch, regulator ceiling rose and the terminal of the fan. Check for the continuity of auxiliary and main winding. Check the capacitor with a Megger. Check for open or loose contact in the resistor or contacts.
5.3	Fan runs in alternate direction.	The capacitor is not in circuit or it could be faulty.	Check with multimeter or replace.
5.4	Electrical hum	Electronic speed controllers can generate an electrical hum. If a variable speed drive (VSD) is fitted incorrectly it can cause a high level of harmonics in the supply. Phase imbalance on three-phase motor. Motor is not designed for the electric supply i.e. wrong voltage or frequency.	If the electronic controller is not faulty explore using a SSC single-phase 2-speed switch in its place. Alternatively, use an auto-transformer speed controller. Check the installation conforms to the VSD supplier's recommendations. Check and correct the supply. Check the electrical supply matches the motor nameplate.
5.5	Motor overheating or high current draw.	Faulty instruments. Incorrect power supply Excessive dirt on the motor cooling fins so the heat is not able to dissipate.	Ensure all instruments are accurate and calibrated where necessary. Check the electrical supply matches the motor nameplate. Remove the dirt and dust on the motor body and between the cooling fins. Increase the maintenance frequency.



School of Electrical Skills
Session: 2020-21 (Summer Semester)
B. Voc. Program, III/V Semester,
End-Sem. Examination

Course Code: ELE 1121

Time: 2 Hours

Course Name: Repairing and Servicing of Electrical Appliances

Max. Marks: 50

Instruction: Answer all questions from section A, each question carries one mark. Answer all questions from section B, each question carries four marks. Answer all questions from section C, each question carries six marks. Scientific calculator is allowed.

Section – A

10X01 = 10 Marks

1. The S.I. unit of power is:

- (a) Henry
- (b) Coulomb
- (c) Watt
- (d) Watt-hour

2. The current I in the circuit is:

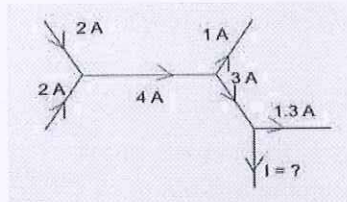

- (a) 1.7
 - (b) 1
 - (c) 2.7
 - (d) 3.7
3. What is other name of mega-ohmmeter?
- (a) Earth Tester
 - (b) Megger
 - (c) Phase Tester
 - (d) Multi Meter
4. Tool which we use for judge the quality and reliability of our work.
- (a) Inventory list
 - (b) Check-list
 - (c) Stock-register
 - (d) work-permit
5. In following, which is not the part of fire triangle?
- (a) Heat
 - (b) Fuel
 - (c) CO₂
 - (d) O₂
6. In following, Which in not the part of fire detection and alarm system?
- (a) Power Supply/Batteries
 - (b) Programing Unit
 - (c) MCP
 - (d) Detectors
7. Which one is not the type of a lightening arrester?
- (a) Rod gap arrester
 - (b) Expulsion type lightning arrester
 - (c) Valve type lightning arrester
 - (d) Tube type lightening arrester
8. Full form of MCP in fire safety system is:
- (a) Manual Call Point
 - (b) Manual circuit point
 - (c) Machine call point
 - (d) Manual cross point
9. What is the power consumed by the resistor of 20 ohm connected 100 V source?
- (a) 500 W
 - (b) 50 W
 - (c) 100 W
 - (d) 300 W

10. Battery charging equipment is generally installed:
- In well ventilated location
 - In clean and dry place
 - As near as practical to the battery being charged
 - In location having all above features

Section – B

04X04 = 16 Marks

- Explain the working principle of lightning arrester with diagram and name the different types of lightning arrester.
- Explain the different operating modes of Public announcement system and name the different components of PA system.
- Given the circuit below...

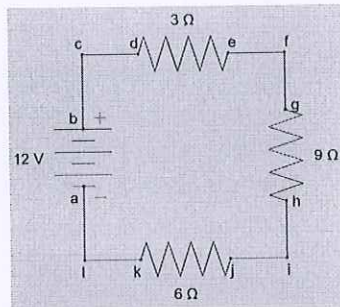

- Calculate the equivalent resistance of the circuit
 - Calculate the current through the battery
4. Differentiate between ammeter and voltmeter.

Section – C

04X06 = 24 Marks

- Name the different types of PPE also describe the different types of hand protection gloves.
- Write any four safe working point of working with:
 - Electrical Power tools
 - Extension Cords
- Explain the operation of electric water heater with diagram.
- What are the possible reasons for non-working of ceiling fan and their solutions?



Answer Key Set – B
Course Code: ELE121,
Course Name: Repairing and Servicing of Electrical Appliances
School of Electrical Skills, Session: 2020-21 (Summer Semester)
B. Voc. Program, III/V Semester, End-Sem. Examination

Section – A

1. (c) Watt
2. (a) 1.7
3. (b) Megger
4. (b) Check-list
5. (c) CO₂
6. (b) Programing Unit
7. (d) Tube type lightening arrester
8. (a) Manual Call Point
9. (a) 500
10. (d) In location having all above features

Section – B

1. Lightning Arrester Working Principle:

When a voltage surge traveling along the conductor reaches the point at which a lightning arrester is installed it breaks down the insulation of the arrester momentarily, allowing the voltage surge to discharge to ground. As soon as the system voltage drops below the predetermined value, insulation between the conductor and ground is restored and further current flow to ground stops.

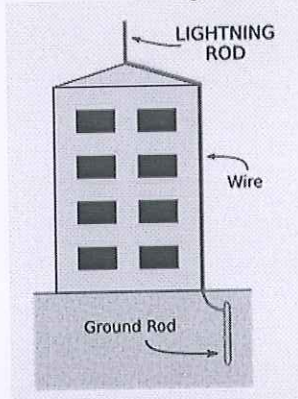

Lightning Arrester Types:

The principle lightning arrester types are as under:

- Rod gap arrester
- Expulsion type lightning arrester
- Valve type lightning arrester

2. **Alert Mode:** also known as emergency mode. PA system sometimes work combined with Fire Alarm system of sometimes work independently. If PAS System call under the alarm then, this system automatically launches by the integrated input from the fire alarm panel and start pre-recorded warning message on all loops on full volume and bypass all other inputs.

Announcement mode: for making an announcement call it's used for general purpose announcement in this mode we can select the specific loop in which we want to make an announcement and also volume control units are also control the volume of announcement in specific areas.

Main component of PA system is:

- Amplifier
- Speakers
- Cables
- Mouth Unit

3. a) Equivalent resistance of the circuit= 18 ohm





Answer Key Set – B
Course Code: ELE1121,

Course Name: Repairing and Servicing of Electrical Appliances
School of Electrical Skills, Session: 2020-21 (Summer Semester)
B. Voc. Program, III/V Semester, End-Sem. Examination

b) Current through the battery= 0.66 A

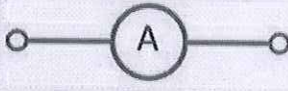
4.

Basis For Comparison	Ammeter	Voltmeter
Definition	The instruments used for measuring the current.	It measures the voltage between any two points of the circuit.
Symbolic Representation		
Resistance	Low	High
Connection	It is connected in series with the circuit.	It is connected in parallel with the circuit.
Accuracy	More	Less
Changing of Range	Not possible	Possible

Section – C

1.

Different equipment of Personal Protection:

- Hand Gloves
- Safety Goggles and Glasses
- Helmets and Head Covers
- Ear Protection buds
- Safety Shoes
- Safety Jacket

Hand Gloves:

- **Cotton and fabric gloves:** These can keep hands clean and protect against abrasions, but may not be strong enough to handle work with rough or sharp materials.
- **Electrical Rubber Gloves:** At the time of working with live electrical wires we should wear protection gloves. Electrical safety gloves are categorized by the level of voltage protection they provide and whether or not they are resistant to ozone. The voltage breakdown is as follows:
 - Class 00 — Maximum use voltage of 500 volts AC/proof tested to 2,500 volts AC
 - Class 0 — Maximum use voltage of 1,000 volts AC/proof tested to 5,000 volts AC
 - Class 1 — Maximum use voltage of 7,500 volts AC/proof tested to 10,000 volts AC
 - Class 2 — Maximum use voltage of 17,000 volts AC/proof tested to 20,000 volts AC
 - Class 3 — Maximum use voltage of 26,500 volts AC/proof tested to 30,000 volts AC
 - Class 4 — Maximum use voltage of 36,000 volts AC/proof tested to 40,000 volts AC
- **Coated fabric gloves:** This type of glove can provide protection against some moderate concentrated chemicals. They can be used in laboratory work provided they are strong enough to protect against the specific chemical being handled.
- **Rubber, plastic or synthetic gloves:** These types of glove can be used when cleaning or working with oils, solvents and other chemicals.



Answer Key Set – B
Course Code: ELE1121,

Course Name: Repairing and Servicing of Electrical Appliances
School of Electrical Skills, Session: 2020-21 (Summer Semester)
B. Voc. Program, III/V Semester, End-Sem. Examination

- **Leather gloves:** These should be used when welding, as the leather can resist sparks and moderate heat. The risk of cuts and abrasions also can be minimized by wearing leather gloves.
- **Aluminized gloves:** These gloves are recommended for welding, furnace and foundry work, as they provide reflective and insulating protection.
- **Kevlar gloves:** These have a wide variety of industrial applications. They are cut- and abrasion-resistant and provide protection against both heat and cold.

Chemical/liquid-resistant gloves: Several types of gloves help protect against specific chemicals

2. Working with Electrical Power Tool Safety

- Use the tool only for its designed purpose.
- Read the Owner's Manual and follow manufacturer's safety instructions.
- Remember electric-powered tools must have a three-wire plug with ground or be double insulated.
- Use of electric-powered tools with a GFCI breakers will drastically reduce the possibility of electric shock or electrocution.
- Wear appropriate PPE.
- If an extension cord is required, make sure it is for the correct wattage and has the proper plugs. Verify condition of the cord and plugs and check for rated use: indoor or outdoor.
- Ensure the power switch is "OFF" before plugging or unplugging tools.
- Never disconnect power by pulling on the cord – use the PLUG.
- Never carry a tool by the cord.
- Unplug the cord before making adjustments, changing/replacing parts/accessories.
- Inspect tool before each use. Replace tool if parts are worn or damaged as seen if Remove from service and tag "Danger, Do Not Operate."
- Do not use electric-powered tools in damp or wet locations.
- Keep the cord away from heat, oil/chemicals, sharp edges and ensure it doesn't become a tripping hazard.

Remember there are specific practices also when drilling or penetrating areas which may contain energized conductors.

- i. Drilling or penetrating areas which contain or may contain energized electrical conductors is considered "working near". Such work requires extreme caution and good planning. Drills or penetrating equipment must be grounded so that accidental contact with an unexpected energized electrical conductor will be cleared quickly by the circuit protective device. Double insulated equipment cannot be counted on to provide protection when accidental contact is made with energized circuits. A drill bit stop should be used to limit the distance of any penetration.
- ii. Enclosures, raceways, compartments, walls, ceilings, floors or underground areas where energized electrical conductors are or may be hidden from direct view must be thoroughly investigated before penetrating into them. The custodian should ensure that an engineering review of drawings or other documentation about the work site is conducted.

Working with Extension Cords

- Inspect the cord before each use. Replace the cord if worn or damaged. Remove from service and tag "Danger, Do Not Operate."
- Keep extension cords away from heat, oil/chemicals, sharp edges and ensure they do not become a tripping hazard.
- Make sure extension cord is for the correct amperage and has the proper plug.
- Verify condition of the cord and plugs and check rated use: indoor or outdoor.
- Don't overload electrical outlets.
- Never disconnect power by pulling on the cord – use the PLUG.

3.

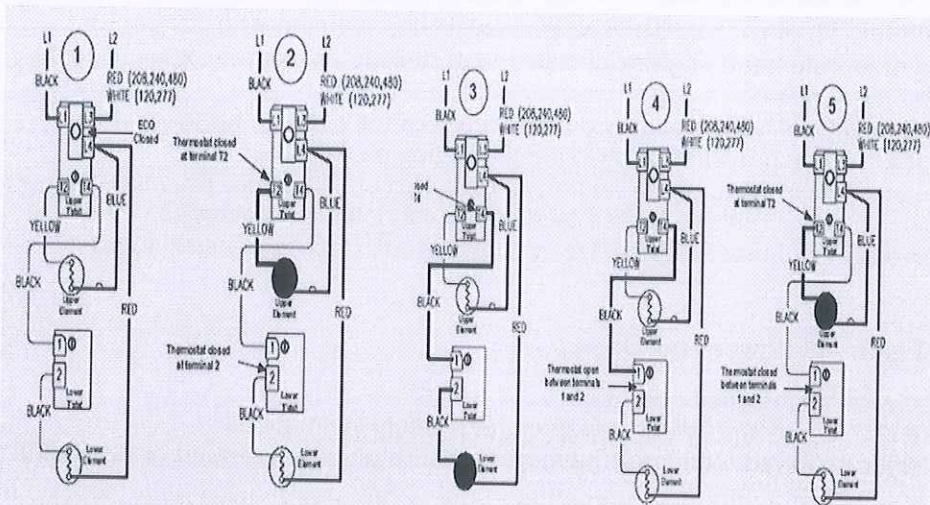

- 1 Line voltage is applied across terminals L1 & L3 of the upper thermostat. ECO is closed, so there is voltage at terminal L4 and to one side of the upper and lower elements.
- 2 Tank is cold therefore both thermostats are closed at terminal T2 & 2 (calling for heat). The circuit is complete through the upper thermostat only, allowing current to flow through upper element.
- 3 When upper thermostat is satisfied, it opens at terminal T2 interrupting current flow through upper element, and closes at terminal T4 allowing voltage to pass to terminal 1 of lower thermostat. This completes the circuit through the lower thermostat and allows current flow through lower element.
- 4 When the lower thermostat is satisfied, it opens at terminal 2 interrupting current flow through lower element. The system is now in stand-by mode waiting for the next call for heat
- 5 The lower thermostat/element combination will generally cycle on and off more often than the upper. In some cases, such as a cold tank or in high demand periods, the upper thermostat will call for heat (opening at terminal T4 and closing at terminal T2) prior to the lower thermostat being satisfied. This will interrupt current flow through the lower thermostat and element and allow current to flow through the upper element only. When the upper thermostat is satisfied, it resumes operation as described in sequence #3 above.

4.

5.1 Fan running the wrong way.	Incorrect wiring.	To reverse the rotation of a three-phase motor interchange any two supply leads. To reverse the rotation of a single-phase motor interchange leads on the start winding. Refer to the directions in the motor junction box. This note applies to single-speed motors only. For 2-speed motors refer to the supplier.
5.2 Fan won't run	Low applied voltage Supply failure Open in winding. Condenser open or short. Open in regulator resistor/switch.	Check the voltage and adjust if possible. Check the supply points at switch, regulator ceiling rose and the terminal of the fan. Check for the continuity of auxiliary and main winding. Check the capacitor with a Megger. Check for open or loose contact in the resistor or contacts.
5.3 Fan runs in alternate direction.	The capacitor is not in circuit or it could be faulty.	Check with multimeter or replace.



Answer Key Set – B
Course Code: ELE121,

Course Name: Repairing and Servicing of Electrical Appliances
School of Electrical Skills, Session: 2020-21 (Summer Semester)
B. Voc. Program, III/V Semester, End-Sem. Examination

5.4 Electrical hum	Electronic speed-controllers can generate an electrical hum. If a variable speed drive (VSD) is fitted incorrectly it can cause a high level of harmonics in the supply. Phase imbalance on three-phase motor. Motor is not designed for the electric supply i.e. wrong voltage or frequency.	If the electronic controller is not faulty explore using a SSC single-phase 2-speed switch in its place. Alternatively, use an auto-transformer speed controller. Check the installation conforms to the VSD supplier's recommendations. Check and correct the supply. Check the electrical supply matches the motor nameplate.
5.5 Motor overheating or high current draw.	Faulty instruments. Incorrect power supply Excessive dirt on the motor cooling fins so the heat is not able to dissipate.	Ensure all instruments are accurate and calibrated where necessary. Check the electrical supply matches the motor nameplate. Remove the dirt and dust on the motor body and between the cooling fins. Increase the maintenance frequency.

