

**BHARTIYA SKILL DEVELOPMENT UNIVERSITY**

School of Electrical Skills

Session: 2020-2021 (Winter Semester)

B. Voc. Program, 5th Semester,2nd In-Sem. Examination

Course Code: ELE 1501

Time: 1 Hour

Course Name: Fundamental of Power Electronics

Section – A

05X01 = 05 Marks

1. When the diode is forward biased, it is equivalent to:
(a) An off switch (b) An On switch (c) A high resistance (d) None of these
2. The three terminals of the IGBT are:
(a) base, emitter & collector (b) gate, source & drain
(c) gate, emitter & collector (d) base, source & drain
3. A PN junction acts as a:
(a) Controlled switch (b) Bidirectional switch
(c) Unidirectional switch (d) None of these
4. A power transistor is a:
(a) three layer, three junction device (b) three layer, two junction device
(c) two layer, one junction device (d) four layer, three junction device
5. Diode allows electric current when it is:
(a) forward biased (a) reverse biased
(c) open circuited (d) none of these

Section – B

03X02 = 06 Marks

1. Define Power MOSFET.
2. What is bipolar junction transistor?
3. A forward potential of 5V is applied to a Si diode. A resistance of 5 K Ω is also in series with the diode. Determine the value of current.

Section – C

03X03 = 09 Marks

1. What is power diode? How do these differ from a signal diode?
2. Explain the reverse biasing operation of PN-junction diode.
3. With neat diagram, explain the working principle of half wave rectifier.



BHARTIYA SKILL DEVELOPMENT UNIVERSITY

School of Electrical Skills

Session: 2020-2021 (Winter Semester)

B. Voc. Program, 5th Semester,
2nd In-Sem. Examination Solution

Course Code: ELE 1501

Course Name: Fundamental of Power Electronics

Answer Key

Section - A

1. Ans: (b)
2. Ans: (c)
3. Ans: (c)
4. Ans: (b)
5. Ans: (a)

Section - B

03X02 = 06 Marks

1. Ans:

- (i) PMOSFET is a unipolar device
- (ii) PMOSFET has lower switching losses.
- (iii) PMOSFET is a voltage controlled device.
- (iv) PMOSFET is used for high frequency applications.

2. Ans:

A bipolar junction transistor is a three layer, two junction n-pn or p-n-p semiconductor device.

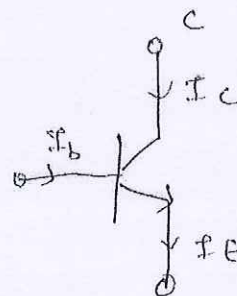

(N-P-N - transistor)



3. Ans:

It is given

Forward potential $V_f = 5V$

Resistance $R_L = 5k\Omega$

For Si-diode the barrier potential is $0.7V$.

So, drop in forward voltage = $5 - 0.7 = 4.3V$.

So, current $I = \frac{V}{R} = \frac{4.3}{5 \times 10^3} = 0.86mA$.

So, $I = 0.86mA$

Section - C

1. Ans:

1. Ans:

Power diode consists of heavily doped n^+ -substrate, on this a lightly doped n^- -layer is grown. basically for high current applications we use power diode.

The current rating of power diode vary from $1A$ to several 1000 amperes. The voltage rating of power diode varies from $50V$ to about $5kV$.

Power diode is differ from a signal diode, as n^- layer is basic structural feature not found in signal diode. As ~~small power~~



2. Ans:

In reverse biased p-n junction diode, the positive terminal of the battery is connected to the n-type semiconductor material and the negative terminal of the battery is connected to the p-type semiconductor material.

When the external voltage is applied to the p-n junction diode in such a way that, negative terminal is connected to the p-type semiconductor and positive terminal is connected to the n-type semiconductor, holes from the p-side are attracted towards the negative terminal whereas free electrons from the n-side are attracted towards the positive terminal.

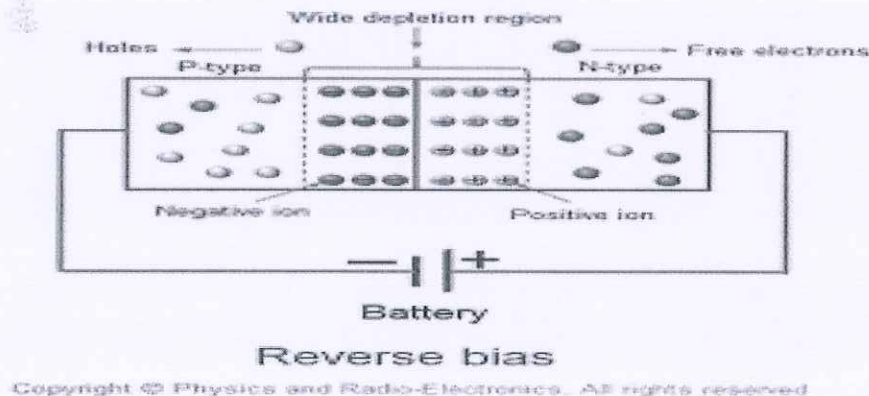

3. Ans:

In half wave rectifier, diode (D) conducts only during positive half cycle of input A.C. supply. The negative half cycle of A.C. supply eliminated from the output.

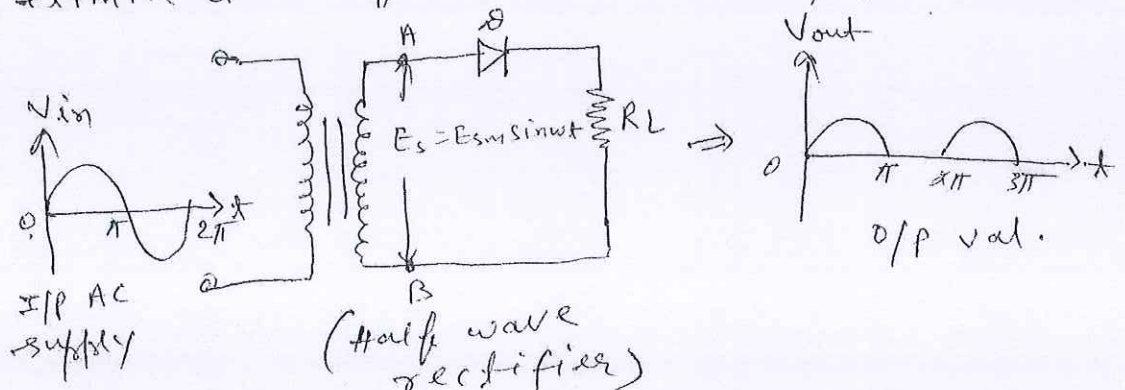



School of Electrical Skills
Session: 2020-21 (Winter Semester)
B. Voc. Program, 5th Semester,
2nd In-Sem. Examination

Course Code: ELE 1502

Time: 1 Hour

Course Name: Substation Practices and Supervision

Max. Marks: 20

Instruction: Answer all questions from section A, each question carries one mark. Answer all questions from section B, each question carries two marks. Answer all questions from section C, each question carries three marks. Scientific calculator is allowed.

Section - A

05X01 = 05 Marks

- 1. What is a load curve?
a) A plot of load Vs current.
b) A plot of load Vs time.
c) A plot of load Vs duration of time.
d) Total number of units generated Vs time.
2. What is the diversity factor?
a) A ratio of kWh generated to the product of plant capacity and the number of hours for which the plant is in operation.
b) The ratio of sum of individual maximum demands to the maximum demand on power stations.
c) The ratio of actual energy produced to the maximum possible energy.
d) The ratio of maximum demand on the power station to the connected load.
3. The salaries of operating labour is a part of operating cost
a) True b) False
4. A tariff should provide incentive for using power during off-peak hours.
a) True b) False
5. Two part tariff is generally used for
a) Industrial consumers
b) Residential consumers
c) Agriculture consumers
d) Commercial consumers

Section - B

03X02 = 06 Marks

- 1. What are the components of annual fixed cost of the power plant?
2. Define the terms: demand factor, maximum demand and connected load.
3. What do you understand by Tariff and what are its objectives?

Section - C

03X03 = 09 Marks

- 1. What is substation? Classify the substations according to the operating voltages and their important features. A residential consumer has the following connected ; 8 bulbs of 100 W each , 2 fans 60 W each and 2 light plug points of 100 W each . His use of electricity during a day is as under:

Table with 2 columns: Time intervals and Connected loads.
12 midnight to 5 am: One fan
5 am to 7 am: Two fans and one light point
7 am to 9 am: NIL
9 am to 6 pm: Two fans
6 pm to midnight: Two fans and four bulbs

Find: (a) connected load (b) maximum demand (c) demand factor

Handwritten signature



2. The load on a power plant on a typical day is as under:
- | Time | 12-5 AM | 5-9 AM | 9-6 PM | 6 PM - 10 PM | 10 PM - 12 AM |
|-----------|---------|--------|--------|--------------|---------------|
| Load (MW) | 20 | 40 | 80 | 100 | 20 |
- Plot the chronological load curve and load duration curve. Find the load factor of the plant and the energy supplied by the plant in 24 hours.

3. The monthly electricity consumption of a residence can be approximated as under:

Light load = 5 tube lights 40 watt each working for 3 hours daily
Fan load = 3 fans 100 watt each working for 5 hours daily
Refrigerator load = 1 kWh daily
Misc. load = 1 kW for one hour daily

Find the monthly bill at the following tariff:

First 15 units = Rs. 2.74 per kWh
Next 25 units = Rs. 2.70 per kWh
Remaining units = Rs. 2.32 per kWh
Constant charge = Rs. 7.00 per month
Discount for prompt payment 5%



Answers Key

Course Code: ELE1502, Course Name: Substation Practices and Supervision
School of Electrical Skills, Session: 2020-21 (Winter Semester)
B. Voc. Program, 5th Semester, 2nd In-Sem. Examination

Section – A

05X01 = 05 Marks

1. What is a load curve?
(b) A plot of load Vs time.
2. What is the diversity factor?
(b) The ratio of sum of individual maximum demands to the maximum demand on power stations.
3. The salaries of operating labour is a part of operating cost
a) True
4. A tariff should provide incentive for using power during off-peak hours.
a) True
5. Two-part tariff is generally used for
a) Industrial consumers

Section – B

03X02 = 06 Marks

1. What are the components of annual fixed cost of the power plant?
Ans: The annual fixed costs of a plant consists of interest, taxes, insurance, depreciation, management and general maintenance costs and rate of return.
2. Define the terms: demand factor, maximum demand and connected load.
Ans: Demand factor is the ratio of the maximum demand to the connected load.
Maximum demand of a consumer means the maximum power that his circuit is likely to draw at any time.
Connected load of a consumer means the sum of the continuous ratings of all the devices and outlets installed on his distribution circuit.
3. What do you understand by Tariff and what are its objectives?
Ans: Ans: Electric utilities derive their income from customers through electricity bills. Different methods of charging customers are known as tariffs. A tariff should fulfill the following objectives and requirements:
 - 1) Cost of capital investment in generation, transmission and distribution equipment must be recovered.
 - 2) Cost of operation, supplies, maintenance and losses must be recovered.
 - 3) Cost of metering, billing, collection and miscellaneous services must be recovered.
 - 4) A satisfactory net return on the capital investment must be ensured.
 - 5) It should be simple and comprehensible to the public.
 - 6) It should be uniform over large population.
 - 7) It should be such that persons creating a desirable and relatively inexpensive type of load make full use and benefit of the electrical appliances.
 - 8) It should provide incentive for using power during the off-peak hours.
 - 9) It should have a provision for higher demand charges for high loads demanded at system peak.
 - 10) It should have a provision of penalty for low factors.
 - 11) It should apportion equitably the cost of service to the different categories of consumers.

Section – C

03X03 = 09 Marks

1. What is substation? Classify the substations according to the operating voltages and their important features. A residential consumer has the following connected ; 8



Answers Key

Course Code: ELE1502, Course Name: Substation Practices and Supervision
School of Electrical Skills, Session: 2020-21 (Winter Semester)
B. Voc. Program, 5th Semester, 2nd In-Sem. Examination

bulbs of 100 W each , 2 fans 60 W each and 2 light plug points of 100 W each . His use of electricity during a day is as under:

12 midnight to 5 am	One fan
5 am to 7 am	Two fans and one light point
7 am to 9 am	NIL
9 am to 6 pm	Two fans
6 pm to midnight	Two fans and four bulbs

Find (a) connected load (b) maximum demand (c) demand factor

Solution. (a) Connected load = $8 \times 100 + 2 \times 60 + 2 \times 100 = 1120 \text{ W}$

(b) Total wattage at different times is

12 midnight to 5 am	60 W
5 am to 7 am	$2 \times 60 + 1 \times 100 = 200 \text{ W}$
7 am to 9 am	NIL
9 am to 6 pm	$2 \times 60 = 120 \text{ W}$
6 pm to midnight	$2 \times 60 + 4 \times 100 = 520 \text{ W}$

The maximum demand is 520 W

(c) Demand Factor = $520/1120 = 0.464$

2. The load on a power plant on a typical day is as under:

Time	12-5 AM	5-9 AM	9-6 PM	6 PM - 10 PM	10 PM – 12 AM
Load (MW)	20	40	80	100	20

Plot the chronological load curve and load duration curve. Find the load factor of the plant and the energy supplied by the plant in 24 hours.

Solution. The chronological load curve is plotted in figure 1. The duration of load is an under:

Load (MW)	100	80 and	40 and	20 and
		above	above	above
Duration	4	13	17	24

The load duration curve is plotted in figure 2. The energy produced by the plant in 24 hours

$$= 100 \times 4 + 80 \times (13-4) + 40 \times (17-13) + 20 \times (24-17) = 1420 \text{ MWh}$$

$$\text{Load factor} = 1420 / (100 \times 24) = 0.5917 \text{ or } 59.17\%$$

Answers Key

Course Code: ELE1502, Course Name: Substation Practices and Supervision
 School of Electrical Skills, Session: 2020-21 (Winter Semester)
 B. Voc. Program, 5th Semester, 2nd In-Sem. Examination

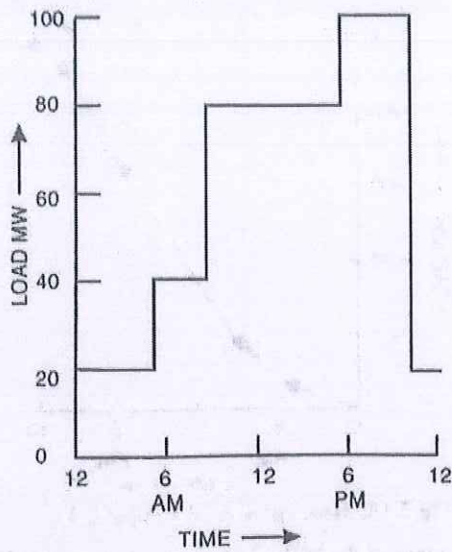

Figure 1

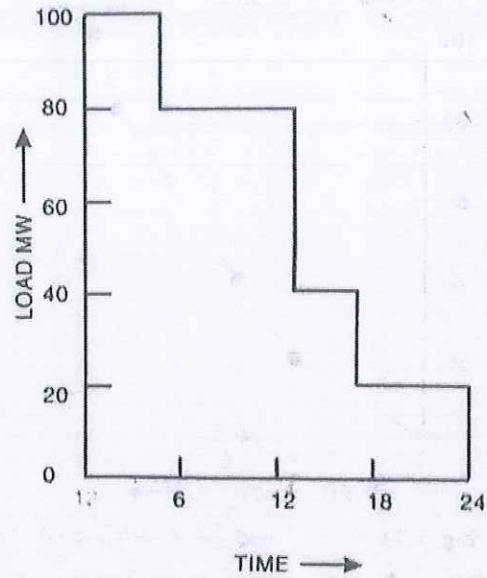

Figure 2

3. The monthly electricity consumption of a residence can be approximated as under:
- Light load = 5 tube lights 40 watt each working for 3 hours daily
 - Fan load = 3 fans 100 watt each working for 5 hours daily
 - Refrigerator load = 1 kWh daily
 - Misc. load = 1 kW for one hour daily
- Find the monthly bill at the following tariff
- First 15 units = Rs. 2.74 per kWh
 - Next 25 units = Rs. 2.70 per kWh
 - Remaining units = Rs. 2.32 per kWh
 - Constant charge = Rs. 7.00 per month
 - Discount for prompt payment 5%
- Ans: Total energy consumption in 30 days = $(5 \times 40 \times 3 \times 30 + 3 \times 100 \times 5 \times 30) \times (1/1000) + 30 + 30 = 18 + 45 + 30 + 30 = 123$ Units
- The monthly bill = Rs. $(7.00 + 2.74 \times 15 + 2.70 \times 25 + 2.32 \times 83) =$ Rs 308.16
- The net monthly bill = $308.16 \times 0.95 =$ Rs. 292.76

**School of Electrical Skills****Session: 2020-21 (Winter Semester)****B. Voc. Electrical Skills, 5th Semester,****2nd In-Sem. Examination****Course Code: ELE 1503****Time: 1 Hour****Course Name: Electrical Machines-II****Max. Marks: 20**

Instruction: Answer all questions from section A, each question carries one mark. Answer all questions from section B, each question carries two marks. Answer all questions from section C, each question carries three marks. Scientific calculator is allowed.

Section – A

05X01 = 05 Marks

1. Slip of Induction Motor at Starting
(a) 0 (b) 1 (c) 0.5 (d) 0.3
2. Slipring Induction Motor is having
(a) High Starting Torque (b) Low Starting Torque
(c) Both (a) & (b) (d) None of these
3. External Resistance is observed in
(a) Squirrel Cage Induction Motor (b) Slip Ring Induction Motor
(c) Both A&B (d) None of these
4. What is the synchronous speed when $F=60\text{Hz}$, $P=6$
(a) 1000 RPM (b) 1100 RPM (c) 1200 RPM (d) 1300RPM
5. The part of the coil in which EMF is generated is known as _____
(a) end connection (b) coil sides
(c) coil span (d) none of the mentioned

Section – B

03X02 = 06 Marks

1. What is meant by Stator? What is meant by Rotor in Electrical Machine?
2. Define Pole Pitch?
3. Why an induction motor will never run at its synchronous speed?

Section – C

03X03 = 09 Marks

1. Draw a typical torque – slip curve and write the condition for maximum torque.
2. A 6-pole induction motor is excited by a 3-phase, 60 Hz source. If the full- load speed is 1140 r/min, calculate the slip.
3. Write difference between Induction and Synchronous Motor.

Section – A

05X01 = 05 Marks

1. Slip of Induction Motor at Starting
(b) 1
2. Slipping Induction Motor is having
(a) High Starting
3. External Resistance is observed in
(b) Slip Ring Induction Motor
4. What is the synchronous speed when $F=60\text{Hz}$, $P=6$
(c) 1200 RPM
5. The part of the coil in which EMF is generated is known as _____
(b) coil sides

Section – B

03X02 = 06 Marks

1. What is meant by Stator? What is meant by Rotor?

In AC/DC motor or Generator, the stationary part of the system is called the Stator, and the rotating components of the system, i.e., either in generator or motor is called the Rotor.

2. Define Pole Pitch?

Pole pitch is defined as the distance between the Centres of two adjacent poles. In which one pole pitch is equal to 180 electrical degrees. We can also describe it as the number of slots per pole.

3. Why an induction motor will never run at its synchronous speed?

If it runs at synchronous speed then there would be no related speed between the two, hence no rotor emf, no rotor current so no rotor torques to maintain rotation. That is why the rotor runs at its synchronous speed.

Section – C

03X03 = 09 Marks

1. Draw a typical torque – slip curve and deduce the condition for maximum torque.

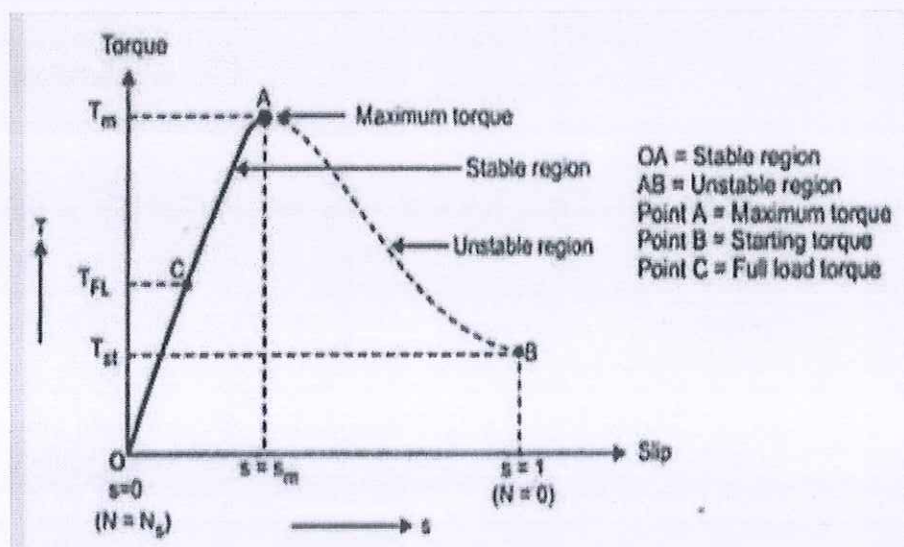



Answers Key

Course Code: ELE1503, Course Name: Electrical Machine-II
School of Electrical Skills, Session: 2020-21 (Winter Semester)
B. Voc. Program, 5th Semester, 2nd In-Sem. Examination

The rotor resistance and rotor reactance should be equal for developing maximum torque
i.e. $R_2 = s X_2$ where s is the slip –under running conditions.

$R_2 = X_2$ under starting conditions

2. A 6-pole induction motor is excited by a 3-phase, 60 Hz source. If the full- load speed is 1140 r/min, calculate the slip.

Solution:

The synchronous speed of the motor is:

$$\begin{aligned} n_s &= 120 f/p = 120 \times 60/6 && \text{Eq. 17-1} \\ &= 1200 \text{ r/min} \end{aligned}$$

The difference between the synchronous speed and rotor speed is the slip speed:

$$\begin{aligned} n_s - n &= 1200 - 1140 = 60 \text{ r/min} \\ s &= (n_s - n)/n_s = 60/1200 && \text{Eq. 17-2} \\ &= 0.05 \text{ or } 5\% \end{aligned}$$

3. Write difference between Induction and Synchronous Motor.

BASIS OF DIFFERENCE	SYNCHRONOUS MOTOR	INDUCTION MOTOR
Type of Excitation	A synchronous motor is a doubly excited machine.	An induction motor is a single excited machine.
Supply System	Its armature winding is energized from an AC source and its field winding from a DC source.	Its stator winding is energized from an AC source.
Speed	It always runs at synchronous speed. The speed is independent of load.	If the load increased the speed of the induction motor decreases. It is always less than the synchronous speed.
Starting	It is not self starting. It has to be run up to synchronous speed by any means before it can be synchronized to AC supply.	Induction motor has self starting torque.
Operation	A synchronous motor can be operated with lagging and leading power by changing its excitation.	An induction motor operates only at a lagging power factor.



Answers Key

Course Code: ELE1503, Course Name: Electrical Machine-II
School of Electrical Skills, Session: 2020-21 (Winter Semester)
B. Voc. Program, 5th Semester, 2nd In-Sem. Examination

BASIS OF DIFFERENCE	SYNCHRONOUS MOTOR	INDUCTION MOTOR
		At high loads the power factor becomes very poor.
Usage	It can be used for power factor correction in addition to supplying torque to drive mechanical loads.	An induction motor is used for driving mechanical loads only.
Efficiency	It is more efficient than an induction motor of the same output and voltage rating.	Its efficiency is lesser than that of the synchronous motor of the same output and the voltage rating.
Cost	A synchronous motor is costlier than an induction motor of the same output and voltage rating	An induction motor is cheaper than the synchronous motor of the same output and voltage rating.



School of Electrical Skills
Session: 2020-21 (Winter Semester)
B. Voc. Program, V Semester,
2nd In-Sem. Examination

Course Code: ELE1505

Time: 1 Hour

Course Name: Advance Automation and Control

Max. Marks: 20

Instruction: Answer all questions from each and every section. Section A, each question carries one mark, section B, each question carries two marks and in section C, each question carries three marks. Scientific calculator is allowed.

Section – A

05X01 = 05 Marks

1. The Full Form of HMI is: -
 - (a) Human Motor Interface
 - (b) Human Module Interface
 - (c) Human Machine Interface
 - (d) None of these
2. The full form of RTU in SCADA system is: -
 - (a) Reset Transmission Unit
 - (b) Remote Terminal Unit
 - (c) Reset Terminal Unit
 - (d) None of these
3. The software used for programming of Allen Bradley PLC is: -
 - (a) Rockwell Automation
 - (b) Micro Ladder
 - (c) Totally Integrated Automation
 - (d) None of these
4. The BOOT-DHCP Server is used to: -
 - (a) Programming of PLC
 - (b) Assigning IP to PLC
 - (c) Simulation of PLC program
 - (d) None of these
5. The programming software SIMATIC WinCC is used for: -
 - (a) PLC
 - (b) SCADA
 - (c) HMI
 - (d) None of these

Section – B

03X02 = 06 Marks

1. Differentiate between HMI & SCADA.
2. Write the name of four types of SCADA system.
3. What are the applications of DCS system?

Section – C

03X03 = 09 Marks

1. Explain the Architecture of SCADA.
2. What are the main features of DCS system?
3. Explain one of the application of SCADA system.



Answers Key

Course Code: ELE1505, Course Name: Advance Automation and Control
School of Electrical Skills, Session: 2020-21 (Winter Semester)
B. Voc. Program, 5th Semester, 2nd In-Sem. Examination

Section – A

05X01 = 05 Marks

1. The Full Form of HMI is: -
(c) Human Machine Interface
2. The full form of RTU in SCADA system is: -
(b) Remote Terminal Unit
3. The software used for programming of Allen Bradley PLC is: -
(a) Rockwell Automation
4. The BOOT-DHCP Server is used to: -
(b) Assigning IP to PLC
5. The programming software SIMATIC WinCC is used for: -
(b) SCADA

Section – B

03X02 = 06 Marks

1. Differentiate between HMI & SCADA.

Ans. SCADA stands for "Supervisory Control and Data Acquisition." These are used for monitoring and controlling large areas, typically a full site or plant. SCADA systems are a combination of many systems including sensors, RTUs or Remote Terminal Units, and PLCs. Data from all of these systems is then sent to the central SCADA unit. That SCADA unit has its own HMI. This is why a lot of people get confused and think SCADA and HMI are one and the same. That HMI or "Human Machine Interface" unit on the SCADA can monitor and control anything that is connected to it. In conclusion, HMI can be part of SCADA but SCADA cannot be part of a HMI. It's that simple. Even our SCADA systems will typically involve an HMI. HMIs are usually connected to one machine or process and are able to monitor and control certain functions of that machine or process.

2. Write the name of four types of SCADA system.

Ans. There are different types of SCADA systems that can be considered as SCADA architectures of four different generations:

1. First Generation: Monolithic or Early SCADA systems,
2. Second Generation: Distributed SCADA systems,
3. Third Generation: Networked SCADA systems and
4. Fourth Generation: Internet of things technology, SCADA systems

3. What are the applications of DCS system?

Ans. Applications of DCS include:

- Chemical plants
- organic compound (oil) and refineries

Answers Key

Course Code: ELE1505, Course Name: Advance Automation and Control
 School of Electrical Skills, Session: 2020-21 (Winter Semester)
 B. Voc. Program, 5th Semester, 2nd In-Sem. Examination

- Pulp and Paper Mills
- Boiler controls and power station systems
- atomic power plants
- Environmental management systems
- Water management systems
- Water treatment plants
- sewerage treatment plants

Section – C

03X03 = 09 Marks

1. Explain the Architecture of SCADA.

Ans. Architecture of SCADA

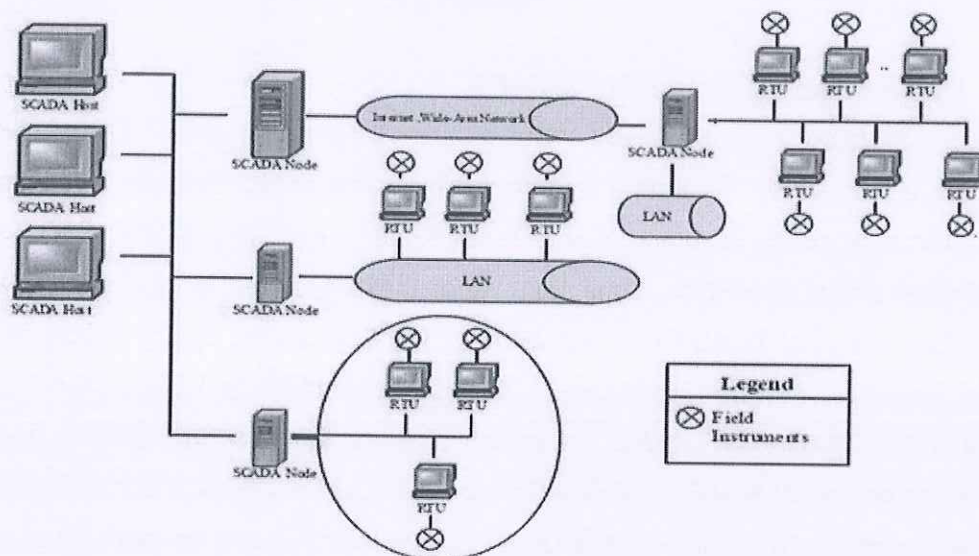

- Generally, the SCADA system includes the following components: local processors, operating equipment, PLCs, instruments, remote terminal unit, intelligent electronic device, master terminal unit or host computers and a PC with human machine interface.
- The block diagram of SCADA system shown in the figure represents the basic SCADA architecture. The SCADA (supervisory control and data acquisition) systems are different from distributed control systems that are commonly found in plant sites. When distributed control systems cover the plant site, SCADA system cover much larger geographic areas.
- In complex SCADA architectures, there are a variety of wired and wireless media & protocols involved in getting data back to the monitoring site. This allows implementation of powerful IP based SCADA networks over landline, mixed cellular and satellite systems. SCADA communications can utilize a diverse range of wired and wireless media.

Answers Key

Course Code: ELE1505, Course Name: Advance Automation and Control
School of Electrical Skills, Session: 2020-21 (Winter Semester)
B. Voc. Program, 5th Semester, 2nd In-Sem. Examination

Answer Key

2. What are the main features of DCS system?

Ans. Main features/merits of DCS system

- Distributive control permits the distribution of the processing task among several controllers.
- Each PLC control its associated machine or process.
- High speed communication among the computers is done through CAT-5 or CAT-6 twisted pair wires, single coaxial cables, fiber optics, or the Ethernet.
- Depending on the process, one PLC failure would not halt the complete process.
- DCS is supervised by a host computer that may perform monitoring/supervising functions such as report generation and storage of data.

3. Explain one of the application of SCADA system.

Ans. SCADA in Power System

- Power system can be defined as constituent of power generation, transmission and distribution. All these sectors are needed to be monitored regularly for improving the system efficiency.
- Thus, the application of SCADA in power system improves the overall efficiency of the system by providing the supervision and control over the generation, transmission and distribution systems.
- SCADA in the power system network increases the system's reliability and stability for integrated grid operation.
- Application of SCADA in Power System can be understand by following fig.

