



Registration No.: .....

## BHARTIYA SKILL DEVELOPMENT UNIVERSITY

Question Paper Format

School of HVAC&R Skills

1<sup>st</sup> Semester, 2<sup>nd</sup> In-Sem. Examination

B. Voc. Program, Summer Semester (2018-19)

Course Code: HVA-1101

Time: 1 Hour

Course Name: Basic of Refrigeration and Air-Conditioning

Max. Marks: 20

### Instructions:

1. Attempt all Questions.
2. Each question of Section – A carries 01 mark.
3. Each question of Section – B carries 02 marks.
4. Each question of Section – C carries 03 marks.

### Section – A

05X01 = 05 Marks

1. The specific volume of a liquid is the reciprocal of:
  - a) Weight density
  - b) Mass density
  - c) Specific weight
  - d) Specific volume
2. Which of the following is a unit of kinematic viscosity?
  - a) Stokes
  - b) Pa-s
  - c)  $m^2/s$
  - d) Poise
3. Which of the following is a shear-thinning fluid?
  - a) Bingham plastic
  - b) Rheopectic
  - c) Dilatant
  - d) Pseudoplastic
4. Which of the following is the condition for the boiling of a liquid?
  - a) The Absolute pressure of a liquid must be greater than or equal to its vapor pressure
  - b) The Absolute pressure of a liquid must be less than or equal to its vapor pressure
  - c) The Absolute pressure of a liquid must be equal to its vapor pressure
  - d) The Absolute pressure of a liquid must be greater than its vapor pressure
5. Which of the following assumption is incorrect in the derivation of Bernoulli's equation?
  - a) The fluid is ideal
  - b) The flow is steady
  - c) The flow is incompressible
  - d) The flow is rotational

### Section – B

03X02 = 06 Marks

1. What are density and specific gravity of fluid?



2. Under what condition fluid is called as Newtonian fluid or Non-Newtonian fluid.
3. Differentiate between the evaporation and boiling.

**Section – C**

03X03 = 09 Marks

1. Write down different types of fluid flow with an example.
2. What is a pure substance? Differentiate between saturation pressure and saturation temperature for pure substance.
3. Explain different types of fluid on the basis of Viscosity.

1  
2  
3  
4

( )

○

1  
2  
3  
4  
5  
6  
7  
8  
9  
10  
11  
12  
13  
14  
15  
16  
17  
18  
19  
20  
21  
22  
23  
24  
25  
26  
27  
28  
29  
30  
31  
32  
33  
34  
35  
36  
37  
38  
39  
40  
41  
42  
43  
44  
45  
46  
47  
48  
49  
50  
51  
52  
53  
54  
55  
56  
57  
58  
59  
60  
61  
62  
63  
64  
65  
66  
67  
68  
69  
70  
71  
72  
73  
74  
75  
76  
77  
78  
79  
80  
81  
82  
83  
84  
85  
86  
87  
88  
89  
90  
91  
92  
93  
94  
95  
96  
97  
98  
99  
100



# BHARTIYA SKILL DEVELOPMENT UNIVERSITY

School of HVAC&R Skills

1<sup>st</sup> Semester, 2<sup>nd</sup> In-Sem. Examination

B. Voc. Program, Summer Semester (2018-19)

Course Code: HVA-1101

Time: 1 Hour

Course Name: Basic of Refrigeration and Air-Conditioning

Max. Marks: 20

Instruction: (Attempt all questions.)

## Section A

- 1) b
- 2) a
- 3) d
- 4) b
- 5) d

## Short answer: Section B

- 1) Density it is the ratio of mass to volume (mass/volume), specific gravity it is the ratio of density of any fluid to density of standard fluid i.e. water
- 2) Newtonian fluid: when shear stress is directly proportional to rate of shear strain, non-Newtonian fluid: Shear stress is not directly proportional to rate of shear strain
- 3) Evaporation: from liquid to vapour, spontaneous process, slow process. Boiling: from solid to liquid, forced process, fast process.

## Long answer question Section C

- 1) Types of fluid flow: a) steady and unsteady flow, b) uniform and non-uniform flow, c) laminar and turbulent flow, d) compressible and incompressible flow, e) natural and forced flow
- 2). Pure substances it that which has invariable homogenous chemical composition throughout its mass.  
Saturation pressure: for a given temperature the pressure at which pure substance changes its phase is called saturation pressure.  
Saturation temp: for a given pressure the temperature at which pure substance changes its phase is called saturation pressure.
3. Newtonian fluid, non-Newtonian fluid, pseudoplastic fluid, dilatant, thixotropic, ideal solid etc.





Registration No.: .....

## BHARTIYA SKILL DEVELOPMENT UNIVERSITY

School of HVAC&R

I Semester, 2<sup>nd</sup> In-Sem. Examination

B. Voc. Program, Summer Semester (2018-19)

Course Code: HVA1102

Time: 1 Hour

Course Name: Assembly & Installation of Refrigerator

Max. Marks: 20

### Instructions:

1. Each question of Section – A carries 01 mark.
2. Each question of Section – B carries 02 marks.
3. Each question of Section – C carries 03 marks.

### Section – A

05X01 = 05 Marks

1. In a vapor compression system, the condition of refrigerant is dry saturated vapor :
  - a. Before entering the compressor
  - b. Before entering the condenser
  - c. After leaving the compressor
  - d. After leaving the condenser
2. Expansion Device is responsible for:
  - a. High Temperature & High Pressure
  - b. Low Temperature & High Pressure
  - c. Low Temperature & Low Pressure
  - d. None of these
3. Clamp meter is used for measuring:
  - a. Temperature
  - b. Pressure
  - c. Resistance
  - d. All of the above
4. Which component divides your VCERS as high side and low side?
  - a. Compressor
  - b. Condenser
  - c. Expansion device
  - d. Evaporator

5. Which is the correct arrangement of components in a VCRS:
- Evaporator – Compressor – condenser – Expansion Device
  - Evaporator – Condenser - Compressor – Expansion Device
  - Evaporator – Expansion Device -Condenser – Compressor
  - Expansion Device - Evaporator – Condenser - Compressor

**Section – B**

03X02 = 06 Marks

- Write the name of five tools in the tool bag of an HVAC&R Technician.
- Write down the general safety rules for an HVAC&R Technician.
- Write down the name of accessories used in a refrigerator.

**Section – C**

03X03 = 09 Marks

- Which refrigerant is used in a domestic refrigerator and which portion represents sub cooling liquid region?
- Explain the process of defrosting in freezer of the refrigerator.
- Explain refrigeration system. Which type of evaporator is used in freezer of the refrigerator?



# BHARTIYA SKILL DEVELOPMENT UNIVERSITY

## School of HVAC&R

I Semester, 2<sup>nd</sup> In-Sem. Examination

B. Voc. Program, Summer Semester (2018-19)

Course Code: HVA1102

Time: 1 Hour

Course Name: Assembly & Installation of Refrigerator

Max. Marks: 20

### Answer sheet

#### Section – A

05X01 = 05 Marks

1. In a vapor compression system, the condition of refrigerant is dry saturated vapor
  - a. Before entering the compressor
2. Expansion Device is responsible for
  - c. Low Temperature & Low Pressure
3. Clamp meter is used for measuring
  - c. Resistance
4. Which component divides your VCRS as high side and low side?
  - c. Expansion device
5. Which is the correct arrangement of components in a VCRS.
  - a. Evaporator – Compressor – condenser – Expansion Device

#### Section – B

03X02 = 06 Marks

1. Write the name of five tools in the tool bag of an HVAC&R Technician.

Ans. a. Clamp Meter

- b. Electric Tester
- c. Thermometer
- d. Pressure Gauge
- e. Megger

2. Write down the general safety rules for an HVAC&R Technician.

Ans. a. Use proper safety tools

- b. Don't touch electrical equipment directly.
- c. Check the tools before its use.
- d. Don't use already damage tools

3. Write down the name of accessories used in a refrigerator.

Ans. a. OLP

- b. Relay
- c. Capacitor

**BHARTIYA SKILL DEVELOPMENT UNIVERSITY**

d. Timer

**Section – C**

03X03 = 09 Marks

1. Which refrigerant is used in a domestic refrigerator and which portion represents sub cooling liquid region?

Ans. Modern refrigerators usually use a refrigerant called **HFC-134a** (1,1,1,2-Tetrafluoroethane), which does not deplete the ozone layer. Region from **exit of condenser to entry of expansion device** represents the subcooled liquid region.

2. Explain the process of defrosting in freezer of the refrigerator?

Ans. The process of removing the ice or frost from the evaporator or freezer is called as defrosting.

**Various Methods of Defrosting****1. Manual Defrosting**

This is the oldest method of defrosting used in the earliest refrigerators that had no automatic defrost systems. When the householder sees the layer of ice on the evaporator coil of the freezer, they simply shut down the refrigerator and keep its doors open. Since the compressor has stopped there is no more formation of the cooling effect and the cabinet of refrigerator starts getting heated. The ice on the evaporator coil starts melting and gets completely removed after certain period of time thus completing the process of defrosting.

**2. Automatic Defrosting ( Defrosting timer)**

The modern day refrigerators are fitted with thermostat that enables the user to set certain temperature in the freezer compartment as per their requirement. Besides this, there is a small plastic tray below the freezer compartment where the excess water from freezer is collected. When the temperature set by the user is attained the thermostat stops supply of power to the compressor and there is halt in production of the cooling effect.

3. Explain refrigeration system? Which type of evaporator is used in freezer of the refrigerator?

## BHARTIYA SKILL DEVELOPMENT UNIVERSITY

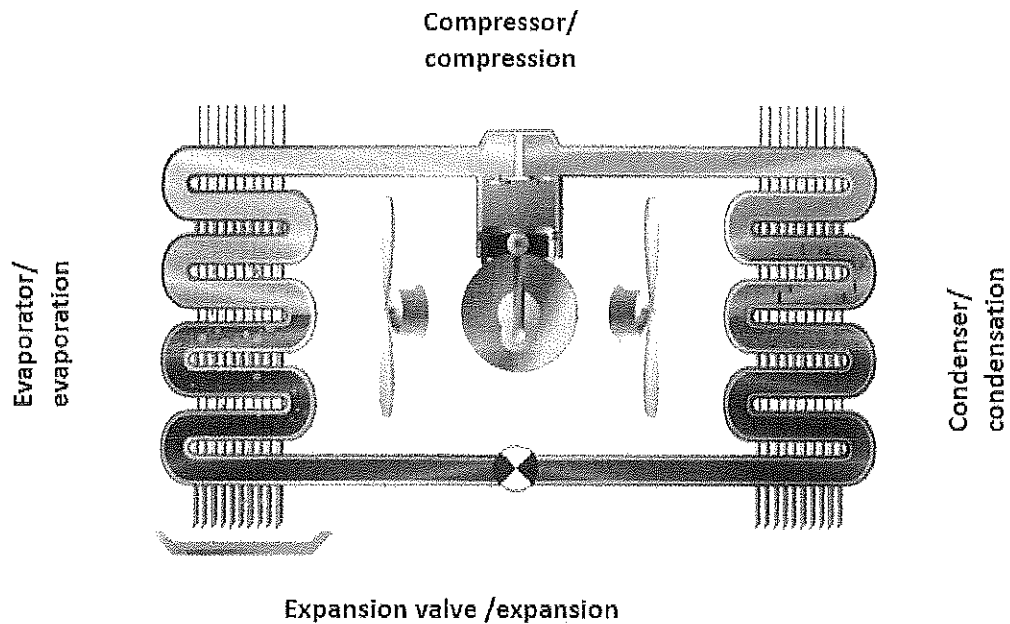

- ✓ Fin type evaporator in domestic refrigerator and flooded type evaporator in commercial refrigeration system.
- ✓ In refrigeration system temperature is much lower than air conditioning system.

100

100

100

100



Registration No.: .....

## BHARTIYA SKILL DEVELOPMENT UNIVERSITY

### School of HVAC&R

I Semester, 2<sup>nd</sup> In-Sem. Examination

B. Voc. Program, Summer Semester (2018-19)

Course Code: HVA1103

Time: 1 Hour

Course Name: Assembly and Installation of Air-conditioning

Max. Marks: 20

#### Instructions:

1. Attempt all Questions.
2. Each question of Section – A carries 01 mark.
3. Each question of Section – B carries 02 marks.
4. Each question of Section – C carries 03 marks.

#### Section – A

05X01 = 05 Marks

1. Heat flows in what direction?
  - A. Cold to warm.
  - B. Warm to cold.
  - C. Liquid to gas.
  - D. All of the above
2. Most substances change their physical state by:
  - A. becoming invisible
  - B. the addition or removal of heat
  - C. becoming molecules
  - D. the addition of heat only
3. Cold or low temperatures \_\_\_\_\_ :
  - A. cause the molecules to move more quickly,
  - B. slow bacteria growth,
  - C. cause increased bacteria growth,
  - D. cause food to become spoiled
4. Refrigerant fluids are \_\_\_\_\_ :
  - A. fluids that absorb heat inside a room
  - B. fluids that release heat outside of a room
  - C. fluids that absorb heat outside of a room
  - D. Both A and B.

( )

( )

... ..

5. Gauge manifold includes a \_\_\_\_\_ :

- A. Center gauge
- B. high-side gauge
- C. low-side gauge
- D. high- and low-side Gauge

**Section – B**

03X02 = 06 Marks

1. What is Thermostatic Expansion Valve (TEV) system in Air-conditioner?
2. Write the classifications of compressor with their applications.
3. Where is wind fin type condenser used?

**Section – C**

03X03 = 09 Marks

1. Describe the effect of evaporator and condenser pressure on the performance of a Vapour Compression Refrigeration System.
2. Write the safety precautions in installation of Air conditioners.
3. Define:
  - i) Ton of refrigeration,
  - ii) Coefficient of performance.

( )

○



# BHARTIYA SKILL DEVELOPMENT UNIVERSITY

## School of HVAC&R

I Semester, 2<sup>nd</sup> In-Sem. Examination

B. Voc. Program, Summer Semester (2018-19)

Course Code: HVA1103

Time: 1 Hour

Course Name: Assembly and Installation of Air-conditioning

Max. Marks: 20

### Answer

#### Section – A

05X01 = 05 Marks

1. Heat flows in what direction?  
B. Warm to cold.
2. Most substances change their physical state by:  
B. the addition or removal of heat
3. Cold or low temperatures \_\_\_\_\_ :  
B. slow bacteria growth,
4. Refrigerant fluids are \_\_\_\_\_ :  
D. Both A and B.
5. Gauge manifold includes a \_\_\_\_\_ :  
A. high- and low-side Gauge

#### Section – B

03X02 = 06 Marks

1. What is Thermostatic Expansion Valve (TEV) system in Air-conditioner?  
A thermal expansion valve (often abbreviated as TEV, TXV, or TX valve) is a component in refrigeration and air conditioning systems that controls the amount of refrigerant released into the evaporator thereby controlling superheat. Thermal expansion valves are often referred to generically as "metering devices".
2. Write the classifications of compressor with their applications.

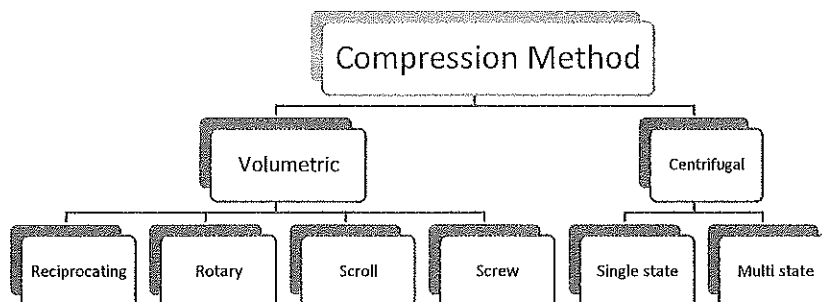

3. Where is wind fin type condenser used?  
In split and window AC

### Section – C

03X03 = 09 Marks

1. Describe the effect of evaporator and condenser pressure on the performance of a Vapour Compression Refrigeration System.

Evaporator pressure is low to make the refrigerant at low temperature then space to absorb heat.

Condensor pressure is high to raise the temperature more than space to dissipate heat into environment.

2. Write the safety precautions in installation of Air conditioners.

1. Tubing should be bent in as large a radius as possible,
2. "Mushroom" heads should be ground off from chisels and punches. Fragments may fly off when struck with the hammer, causing serious injury.
3. Files should never be used without handles. The tang may injure the hands.
4. Wear goggles when drilling. Chips may fly.
5. Emery cloth should not be used to clean tubing to prepare for soldering. It may leave an oily deposit.
6. Also the hard grit could cause considerable damage if allowed to enter the refrigerating mechanism.
7. When pressure testing for leaks in tubing circuits, use low or medium pressure carbon dioxide or nitrogen. Never use oxygen.

3. Define:

- i) Ton of refrigeration,

A ton of refrigeration (TR), also called a refrigeration ton (RT), is a unit of power used in some countries (especially in North America) to describe the heat-extraction capacity of refrigeration and air conditioning equipment. It is defined as the rate of heat transfer that results in the melting of 1 short ton (2,000 lb; 907 kg) of pure ice at 0 °C (32 °F) in 24 hours.

- ii) Coefficient of performance.

Ratio of work or useful output to the amount of work or energy input, used generally as a measure of the energy-efficiency of air conditioners, space heaters and other cooling and heating devices. COP equals heat delivered (output) in British thermal units (Btu) per hour divided by the heat equivalent of the electric energy input (one watt = 3.413 Btu/hour) or, alternatively, energy efficiency ratio divided by 3.413. Higher the COP, higher the efficiency of the equipment.



Registration No.: .....

## BHARTIYA SKILL DEVELOPMENT UNIVERSITY

### School of HVAC&R

I Semester, 2<sup>nd</sup> In-Sem. Examination

B. Voc. Program, Summer Semester (2018-19)

Course Code: HVA1104

Time: 1 Hour

Course Name: Sheet Metal and Welding

Max. Marks: 20

#### Instructions:

1. Attempt all Questions.
2. Each question of Section – A carries 01 mark.
3. Each question of Section – B carries 02 marks.
4. Each question of Section – C carries 03 marks.

#### Section – A

05X01 = 05 Marks

1. Stakes are usually used as \_\_\_\_\_,
  - A. supporting and forming tools
  - B. Shearing
  - C. Punching
  - D. Riveting
2. Shearing is a process of \_\_\_\_\_,
  - A. Sheet metal cutting operation along a straight line
  - B. Sheet metal bending operation along a straight line
  - C. Notching
  - D. Embossing
3. The process of increase in angle of bent part after forming tool removed is:
  - A. Embossing
  - B. Spring back
  - C. Hem
  - D. Blanking
4. Sheet metal forming process of shock wave whose energy is transmitted to force part into cavity is known as:
  - A. Explosive forming
  - B. Drawing
  - C. Electromagnetic forming
  - D. Piercing

5. In the process of an axially symmetric part is gradually shaped over a rotating mandrel using a rounded tool or roller in sheet metal is:

- A. bending
- B. shearing
- C. punching
- D. spinning

**Section – B**

03X02 = 06 Marks

1. What is meant by SWG? Give the 4 values of SWG in sheet metal.
2. Name the tools used to cut sheet metal.
3. What are three major categories of sheet metal process?

**Section – C**

03X03 = 09 Marks

1. What are commonly used methods of sheet-metal joints?
2. State any four applications of sheet metals.
3. Explain with sketch the following sheet metal operations:
  - a) Bending
  - b) Drawing.

**BHARTIYA SKILL DEVELOPMENT UNIVERSITY****School of HVAC&R**I Semester, 2<sup>nd</sup> In-Sem. Examination

B. Voc. Program, Summer Semester (2018-19)

Course Code: HVA1104

Time: 1 Hour

Course Name: Sheet Metal and Welding

Max. Marks: 20

Answers:

**Section – A**

05X01 = 05 Marks

1. Stakes are usually used as \_\_\_\_\_,  
A. supporting and forming tools
2. Shearing is a process of \_\_\_\_\_,  
A. Sheet metal cutting operation along a straight line
3. The process of increase in angle of bent part after forming tool removed is:  
B. Spring back
4. Sheet metal forming process of shock wave whose energy is transmitted to force part into cavity is known as:  
A. Explosive forming
5. In the process of an axially symmetric part is gradually shaped over a rotating mandrel using a rounded tool or roller in sheetmetal is:  
D.spinning

**Section – B**

03X02 = 06 Marks

1. What is meant by SWG? Give the 4 values of SWG in sheet metal.

It is an measurement of sheet thickness . SWG – Standard wire gauge

2. Name the tools used to cut sheet metal. Snip, shearing press, die punch

3. What are three major categories of sheet metal process?

Forming, joining, cutting

**Section – C**

03X03 = 09 Marks

1. What are commonly used methods of sheet-metal joints?

Hemming, reviting, welding

2. State any four applications of sheet metals.

Cover of machine, automotive body, airplane, roofs of buildings

3. Explain with sketch the following sheet metal operations:

a) Bending: It is a forming process, Sheet metal bending is the plastic deformation of the work over an axis, creating a change in the part's geometry.

b) Drawing: It is a sheet metal forming process in which a sheet metal blank is radially drawn into a forming die by the mechanical action of a punch. It is thus a shape transformation process with material retention. Example utensil, fripan etc

**BHARTIYA SKILL DEVELOPMENT UNIVERSITY****School of HVAC & R Skills  
First Semester, 2<sup>nd</sup> In-Sem. Examination  
B. Voc. Program, Summer Semester (2018-19)****Course Code: HVA 1105****Time: 1 Hour****Course Name: RAC Electrical****Max. Marks: 20**

**Instruction:** All questions are compulsory. Answer all questions from section A, each question carries one mark. Answer all questions from section B, each question carries two marks. Answer all questions from section C, each question carries three marks. Scientific calculator can be used.

**Section – A**

05X01 = 05 Marks

Q.1. Fleming's right hand rule is used for: -

- (a) Motor                      (b) Transformer                      (c) Induction machine                      (d) Generator

Q.2. An electric current coming out from the page. What is the direction of the magnetic field?

- (a) To the bottom of the page                      (b) To the top of the page  
(c) Clockwise                      (d) Counter-clockwise.

Q.3. Basic source of magnetism is: -

- (a) Charged particles alone                      (b) Movement of charged particles  
(c) Magnetic dipoles                      (d) Magnetic domains

Q.4. Unit of magnetic flux is: -

- (a) Wb /m<sup>2</sup>                      (b) Wb/A.m                      (c) Wb                      (d) Tesla/m

Q.5. Pole which points towards north is: -

- (a) N-pole                      (b) S-pole                      (c) W-pole                      (d) E-pole

**Section – B**

03X02 = 06 Marks

Q.1. What do you understand by Fleming's left hand rule?

Q.2. Define the laws of magnetism.

Q.3. Discuss the properties of magnetic lines of force.

**Section – C**

03X03 = 09 Marks

Q.1. Explain Faraday's law of electromagnetic induction.

Q.2. Distinguish between magnetic and electrical circuits.

Q.3. A conductor of active length 0.3 m moves in a magnetic field at a linear velocity of 100 m/s. If the magnetic flux density is 0.05 T, calculate the average value of the induced e.m.f. if the direction of movement of conductor is:

- (a) Perpendicular to the field                      (b) At 30° to the direction of the field

(1)

1950  
1951  
1952

1953  
1954  
1955

(2)

1956  
1957  
1958  
1959  
1960

Course code: - HVA1105

Course Name: - RAC Electrical

---

### Section-A

1. Ans  $\rightarrow$  (d)
2. Ans  $\rightarrow$  (d)
3. Ans  $\rightarrow$  (b)
4. Ans  $\rightarrow$  (c)
5. Ans  $\rightarrow$  (a)

### Section-B

1. Ans:

Fleming's left hand rule is applicable for motor.

According to this rule, hold the thumb, fore fingers, and middle finger of left hand at right angle to each other, just like  $x, y$  and  $z$ , axis of 3-D, then thumb points in direction of motion of conductor, forefinger in the direction of magnetic field and middle finger gives the direction of the induced emf (voltage).

Q. Ans: -

There are two fundamental laws of magnetism which are as follows: -

1) Law 1: - It states that like magnetic poles repel and unlike poles attract each other.

(ii) Law 2: - This is experimentally proved by scientist Coulomb and hence also known as Coulomb's law: -

The force ( $F$ ) ~~is~~ exerted by one pole on the other pole is: -

(a) Directly proportional to product of the pole strengths.

(b) Inversely proportional to square of distance between them, and

(c) Nature of medium surrounding the pole mathematically,

$$F \propto \frac{M_1 M_2}{d^2}$$

$$F = k \cdot \frac{M_1 M_2}{d^2}$$

where  $M_1$  and  $M_2$  are pole strength of poles while 'd' is distance between

the poles.

3. Ans:

These are the properties of magnetic lines of force: -

- i) Lines of force always originated ~~on~~ from N-pole and terminated on S-pole.
- ii) Lines of force never intersect each other.
- iii) Magnetic lines of force always prefer a path offering least opposition.

Section-C

1. Ans:

According to Faraday law: -

First law: -

Whenever a conductor cuts the magnetic flux lines an e.m.f. will ~~be~~ be induced in that conductor.

Second law: -

The magnitude of induced e.m.f. is

equal to rate of change of flux linkages.

$$e = \frac{\text{change of flux linkage}}{\text{time}}$$

$$e = N \cdot \frac{d\phi}{dt} \quad \text{volts.}$$

where  $e$  = induced e.m.f

$N$  = number of turns in coil

$\frac{d\phi}{dt}$  = rate of change of flux

2. Ans: -

Electric circuit	magnetic circuit
(1) e.m.f is the driving force in electric circuit, the unit is volt.	(1) M.M.F is the driving force in the magnetic circuit, the unit of which is ampere turns.
(2) there is current 'I' in the electric circuit it measured in amperes.	(2) there is flux ( $\phi$ ) in the magnetic circuit measured in weber.
(3) the flow of electrons decides the current in the conductor	(3) the number of magnetic lines of force decide the flux.

### Electric circuit

(4) Resistance opposes the flow of current.

$$(5) R = \rho \frac{l}{A}$$

$$(6) I = \frac{e.m.f}{R}$$

### Magnetic circuit

(5) Reluctance opposes the flow of magnetic flux.

$$(5) S = \frac{l}{\mu A}$$

$$(6) \Phi = \frac{m.m.f}{S}$$

3. Ans: -

$$(a) B = 0.05 \text{ T}, l = 0.3 \text{ m}, v = 100 \text{ m/s}$$

$$E = Blv = 0.05 \times 0.3 \times 100 = 1.5 \text{ V}$$

$$(b) \text{ since } \sin \theta = \sin 30^\circ = 0.5$$

$$E = Blv \sin \theta = ~~1.5 \times 0.5~~ 1.5 \times 0.5 = 0.75 \text{ V}$$

100

( )

( )

100



Registration No.: .....

## BHARTIYA SKILL DEVELOPMENT UNIVERSITY

### School of HVAC Skill

1<sup>st</sup> Semester, 2<sup>nd</sup>-Insem. Examination

B. Voc. Program, Summer (2018-19)

Course Code: HVA1106

Course Name: Basic Electronics for HVAC

Time: 1 Hour

#### Instructions:

1. Each question of Section – A carries 01 mark.
2. Each question of Section – B carries 02 marks.
3. Each question of Section – C carries 03 marks.

Max. Marks: 20

#### Section – A

05X01 = 05 Marks

1. Which one of the following is correct for Rectifier conversion?
  - i) AC to AC,
  - ii) AC to DC
  - iii) DC to AC
  - iv) DC to DC
2. Which one of the following is correct for Si band gap at room temperature?
  - i) 1.12 eV
  - ii) 0.72 eV
  - iii) 2.5 eV
  - iv) 3.34 eV
3. Which one of the following is correct for Photovoltaic conversion?
  - i) Mechanical to light
  - ii) Light to electrical
  - iii) Light to light,
  - iv) electrical to electrical energy
4. Which one of the biases is correct for LED operation?
  - i) Forward bias
  - ii) Reverse bias
  - iii) No bias and
  - iv) Full bias
5. Which one of the following reasons is needed for Transistor as an amplifier?
  - i) Cut-Off
  - ii) Saturation
  - iii) Active
  - iv) Between Cut-Off and active

### Section – B

03X02=06 Marks

1. What do you mean by LED? Between the direct and indirect semiconductors which one is used for LED fabrication?
2. What are the advantages and disadvantages of bridge rectifiers?
3. Is the output of a rectifier perfect DC? Why is Capacitor/Inductor used at the output of a rectifier?

### Section – C

03X03 = 09 Marks

1. Draw and explain the working principle of a Solar cell with a proper band diagram.
2. What are the differences between direct and indirect bandgap semiconductor? Draw and explain these semiconductors with proper band diagrams.
3. What are the types of Transistors on the basis of doping? Draw and explain how electron flow occurs in NPN Common Emitter (CE) configuration?



# BHARTIYA SKILL DEVELOPMENT UNIVERSITY

School of HVAC Skill

1<sup>st</sup> Semester, 2<sup>nd</sup>-Insem. Examination

B. Voc. Program, Summer (2018-19)

HVA1106 Basic Electronics for HVAC

Time: 1 Hour

Max. Marks: 20

Answer sheet

## Section – A

05 objective type questions, each question carries 01 mark.

05X01 = 05 Marks

1. Which one is correct for Rectifier conversion?  
ii)
2. Which one is correct for Si band gap at room temperature?  
i)
3. Which one is correct for Photovoltaic conversion?  
ii)
4. Which one of the bias is correct for LED operation?  
i)
5. Which one of the following region is needed for Transistor as an amplifier?  
iii)

## Section – B

03 short answer type questions, each question carries 02 marks.

06 Marks

1. A light-emitting diode (LED) is a two-lead semiconductor light source. It is a p–n junction diode that emits light when activated.

Direct bandgap semiconductor is used for LED fabrication

2. Advantages and Disadvantages of full Wave Rectifier:

### Advantages

- Step Down Transformer is not required.
- It has higher efficiency than half wave and full wave rectifier.
- The output waveform is continuous.
- To use in a device, a low level filter is required, so thus reducing the cost.

### Disadvantages

- Since four diodes are used, cost of making it is increasing.
- The value of the diodes used should be precise, else there will be an error in rectification.
- The output is not a proper DC quantity. It has ripples in its output.

## BHARTIYA SKILL DEVELOPMENT UNIVERSITY

3. No,

Capacitors or inductor is used to reduce the ripple factor. The function of rectifier is to convert the AC to DC. But, the rectifier output is not perfect DC, where AC retains with DC. So, to reduce the amount of AC superimposed on DC Capacitor/ inductor is used.

### Section – C

03 essay type questions, each question carries 03 marks.

03X03 = 09 Marks

- When light reaches the p-n junction, the light photons can easily enter in the junction, through very thin p-type layer. The light energy, in the form of photons, supplies sufficient energy to the junction to create a number of electron-hole pairs. The incident light breaks the thermal equilibrium condition of the junction. The free electrons in the depletion region can quickly come to the n-type side of the junction. Similarly, the holes in the depletion can quickly come to the p-type side of the junction. Once, the newly created free electrons come to the n-type side, cannot further cross the junction because of barrier potential of the junction

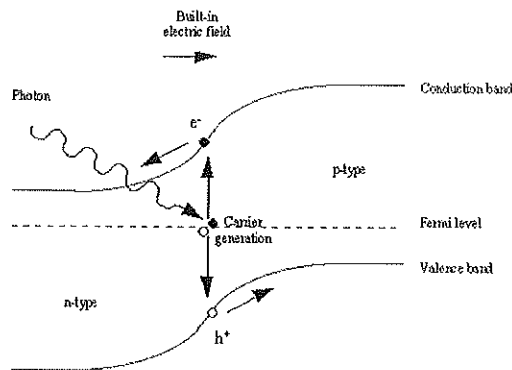

Band diagram for PV

- Indirect-band-gap are defined by the fact that the minimum energy in the conduction band and the maximum energy in the valence band occur at different values of the crystal momentum. This means that an indirect transition occurs from the valence (V.B.) to the conduction band (C.B.) But, in direct bandgap the minima of the CB and maxima of the VB lies at same k value so the electrons directly move from valance band (VB) to conduction band (CB)

In direct semiconductor photons are generated but in indirect photon are generated.

## BHARTIYA SKILL DEVELOPMENT UNIVERSITY

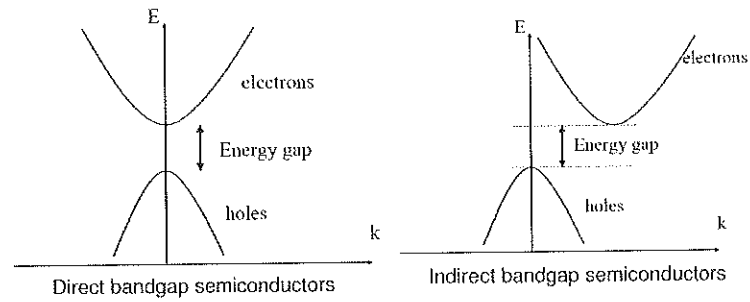

Fig: Direct and indirect band gap semiconductor

3. BJTs come in two types, or polarities, known as PNP and NPN based on the doping types of the three main terminal regions. An NPN transistor comprises two semiconductor junctions that share a thin p-doped region, and a PNP transistor comprises two semiconductor junctions that share a thin n-doped region.

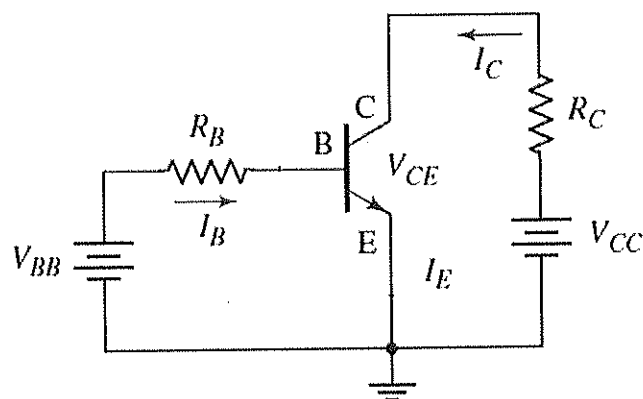
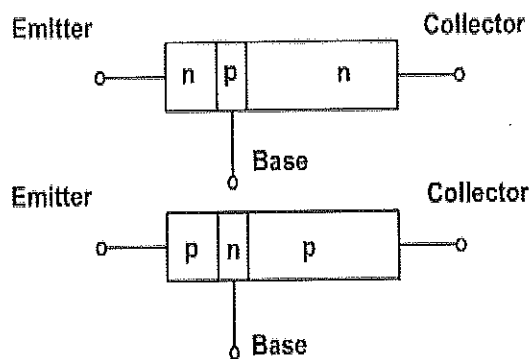

Fig: Common emitter configuration



## BHARTIYA SKILL DEVELOPMENT UNIVERSITY

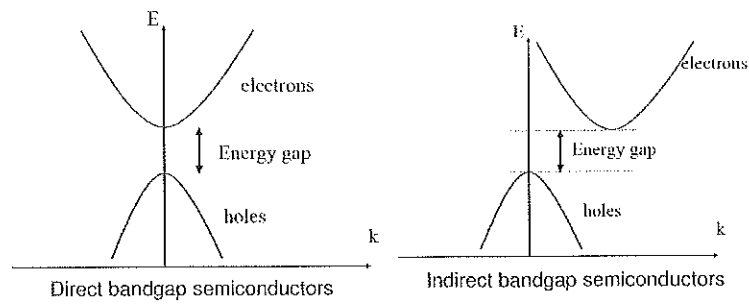

Fig: Direct and indirect band gap semiconductor

- BJTs come in two types, or polarities, known as PNP and NPN based on the doping types of the three main terminal regions. An NPN transistor comprises two semiconductor junctions that share a thin p-doped region, and a PNP transistor comprises two semiconductor junctions that share a thin n-doped region.

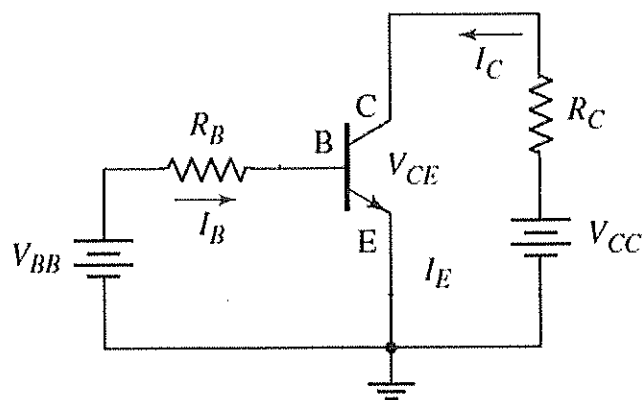
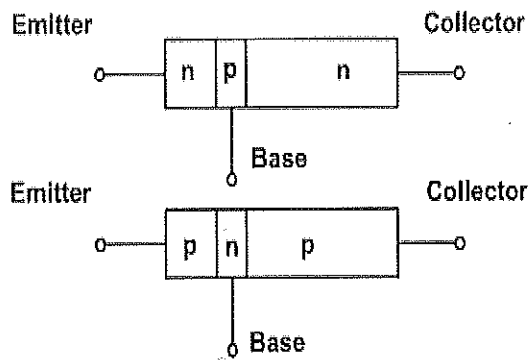

Fig: Common emitter configuration

