



BHARTIYA SKILL DEVELOPMENT UNIVERSITY

School of RAC Skills

III Semester, 2nd In-Sem. Examination

B. Voc. Program, Summer Semester (2019-20)

Course Code: HVA1301

Time: 1 Hour

Course Name: Refrigerant & Psychrometry

Max. Marks: 20

Instruction:

1. Attempt all Questions.
2. Each question of Section – A carries 01 mark.
3. Each question of Section – B carries 02 mark.
4. Each question of Section – C carries 03 mark.

Section – A

05X01 = 05 Marks

1. Specific humidity is measured in-
 - a. g/ Kg of dry air
 - b. kg/m³
 - c. Both a & b
 - d. None of the above
2. In any cooling and dehumidification process which type of heat is being rejected?
 - a. Sensible heat
 - b. Latent heat
 - c. Both a & b
 - d. None of the above
3. An air conditioning system with maximum BPF indicates-
 - a. An efficient system
 - b. An inefficient system
 - c. No effect on system
 - d. None of the above
4. Which one of the following is the correct for sensible cooling operation:
 - a. WBT > DPT
 - b. WBT < DPT
 - c. WBT = DPT
 - d. None of the above





BHARTIYA SKILL DEVELOPMENT UNIVERSITY

5. Specific volume is measured in-

- A. M^3/Kg
- B. Kg/m^3
- C. N/m^2
- D. None of the above

Section – B

03X02 = 06 Marks

1. What are the factors that affect human comfort?
2. Why is sling psychrometer used?
3. What is sensible heat factor and what does it represent on psychrometric chart?

Section – C

03X03 = 09 Marks

1. Write short notes on absorbent and adsorbents.
2. Define different properties of air.
3. A sample of air has DBT 35° and WBT $25^\circ C$. The barometric pressure is 760 mm Hg. Calculate without using psychrometric chart
 - a) Humidity Ratio
 - b) RH
 - c) Enthalpy of sample

md. Najimul Haque

~~Alhaq~~

Q.



BHARTIYA SKILL DEVELOPMENT UNIVERSITY

School of RAC Skills

ANSWER KEY

III Semester, 2nd In-Sem. Examination

B. Voc. Program, Summer Semester (2019-20)

Course Code: HVA1301

Time: 1 Hour

Course Name: Refrigerant & Psychrometry

Max. Marks: 20

Instruction:

1. Attempt all Questions.
2. Each question of Section – A carries 01 mark.
3. Each question of Section – B carries 02 mark.
4. Each question of Section – C carries 03 mark.

Section – A

05X01 = 05 Marks

1. Specific humidity is measured in-
 - a. g/ Kg of dry air
2. In any cooling and dehumidification process which type of heat is being rejected?
 - c. Both a & b
3. An air conditioning system with maximum BPF indicates-
 - b. An inefficient system
4. Which one of the following is the correct for sensible cooling operation:
 - a. WBT > DPT
5. Specific volume is measured in-
 - A. M³/Kg

Section – B

03X02 = 06 Marks

1. What are the factors that affect human comfort?

Ans:-

Air temperature

Air humidity

Air motion

Surrounding temperature

BHARTIYA SKILL DEVELOPMENT UNIVERSITY

Clothing

2. Why is sling psychrometer used?

Ans:-

Used for measuring the DBT & WBT.

3. What is sensible heat factor and what does it represent on psychrometric chart?

Ans:-

$$SHF = SH / TH$$

SHF = sensible heat factor

SH = sensible heat

TH = Total heat

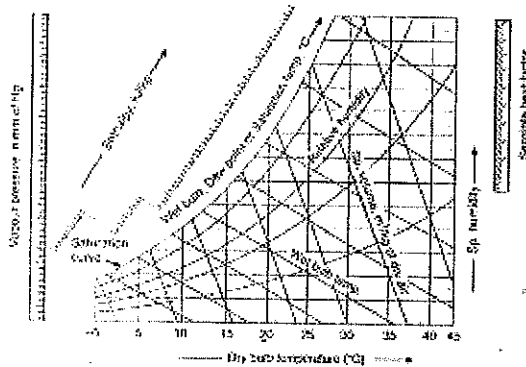

Section – C

03X03 = 09 Marks

1. Write short notes on absorbent and adsorbents.

Ans:-

An absorbent is a material which will take in the liquid or gas uniformly. Absorption occurs when the liquid or gas is being taken into the absorbent material, while adsorption occurs when a liquid, gas or dissolved solid is adhered to the surface of the adsorbent.

2. Define different properties of air.

Ans:-

Dry bulb temperature, T_{db} ($^{\circ}\text{C}$)

Wet bulb temperature, T_{wb} ($^{\circ}\text{C}$)

Moisture content or specific humidity, W (kg water / kg dry air)

Relative humidity (RH), F (%)

Specific volume, V' (m^3/kg dry air)

Enthalpy, H (kJ/kg dry air)

**BHARTIYA SKILL DEVELOPMENT UNIVERSITY**

3. A sample of air has DBT 35° and WBT 25°C . The barometric pressure is 760 mm Hg. Calculate without using psychrometric chart
- Humidity Ratio
 - RH
 - Enthalpy of sample

Ans:-

Use the carrier equation, find vapor partial pressure= 2.5 KPa

Now

Humidity Ratio= 15 g/Kg of dry air

Relative humidity= 44%

Enthalpy = 75.8 KJ/Kg



**BHARTIYA SKILL DEVELOPMENT UNIVERSITY****School of RAC Skills****3rd Semester, 2nd In-Sem. Examination****B. Voc. Program, Summer Semester (2019-20)****Course Code: HVA-1302****Time: 1 Hour****Course Name: Compressor, Condenser and Evaporator****Max. Marks: 20****Instruction: Attempt all questions.****Section – A****05X01 = 05 Marks**

1. The condition of refrigerant after passing through the condenser in a vapour compression system:
 - a) Saturated Liquid
 - b) Wet vapour
 - c) Dry saturated vapour
 - d) Superheated vapour
2. During a refrigeration cycle, heat is rejected by the refrigerant in a:
 - a) Condenser
 - b) Compressor
 - c) Evaporator
 - d) Expansion valve
3. The condensing medium used in evaporative condensers is:
 - a) Air
 - b) Water
 - c) Both air and water
 - d) None of these
4. Most air cooled condenser are designed to operate with a temperature difference of?
 - a) 5° C
 - b) 8° C
 - c) 14° C
 - d) 22° C
5. The natural convection air cooled condensers are used in:
 - a) Domestic refrigerator
 - b) Water cooler
 - c) Room air conditioners
 - d) All of these

Section – B**03X02 = 06 Marks**

1. Write down classifications of condenser.
2. Differentiate between air cooled and water cooled condenser.
3. What is fouling factor in condenser?



BHARTIYA SKILL DEVELOPMENT UNIVERSITY

Section – C

03X03 = 09 Marks

1. Explain with neat sketch principle and working of induced draft cooling tower.
2. Explain with neat sketch construction and working of shell and tube condenser.
3. What are the points to be considered for selecting a condenser?

A₂
A

BHARTIYA SKILL DEVELOPMENT UNIVERSITY

School of RAC Skills

3rd Semester, 2nd In-Sem. Examination

B. Voc. Program, Summer Semester (2019-20)

Course Code: HVA-1302

Time: 1 Hour

Course Name: Compressor, Condenser and Evaporator

Max. Marks: 20

Instruction: (Attempt all questions.)

Section A

- 1) a
- 2) a
- 3) c
- 4) c
- 5) d

Short answer: Section B

- 1) Classification of condenser: Air cooled condenser and water cooled condenser
- 2) Air cooled: construction is very much simple, no handling problem, no corrosion and fouling factor, low heat transfer, low capacity 5TR
water cooled: construction is complicated, difficult to handle, corrosion and fouling are more, large heat transfer and large capacity
- 3) Fouling factor is reciprocal of heat transfer coefficient for the material of scale.

Long answer question Section C

1)

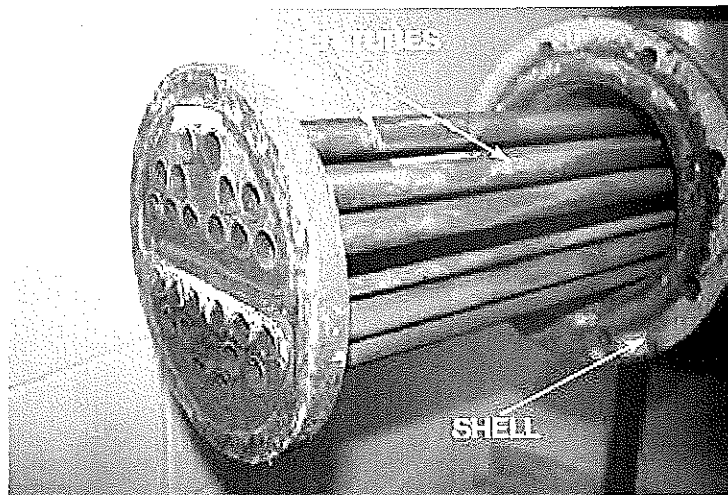

2)

BHARTIYA SKILL DEVELOPMENT UNIVERSITY

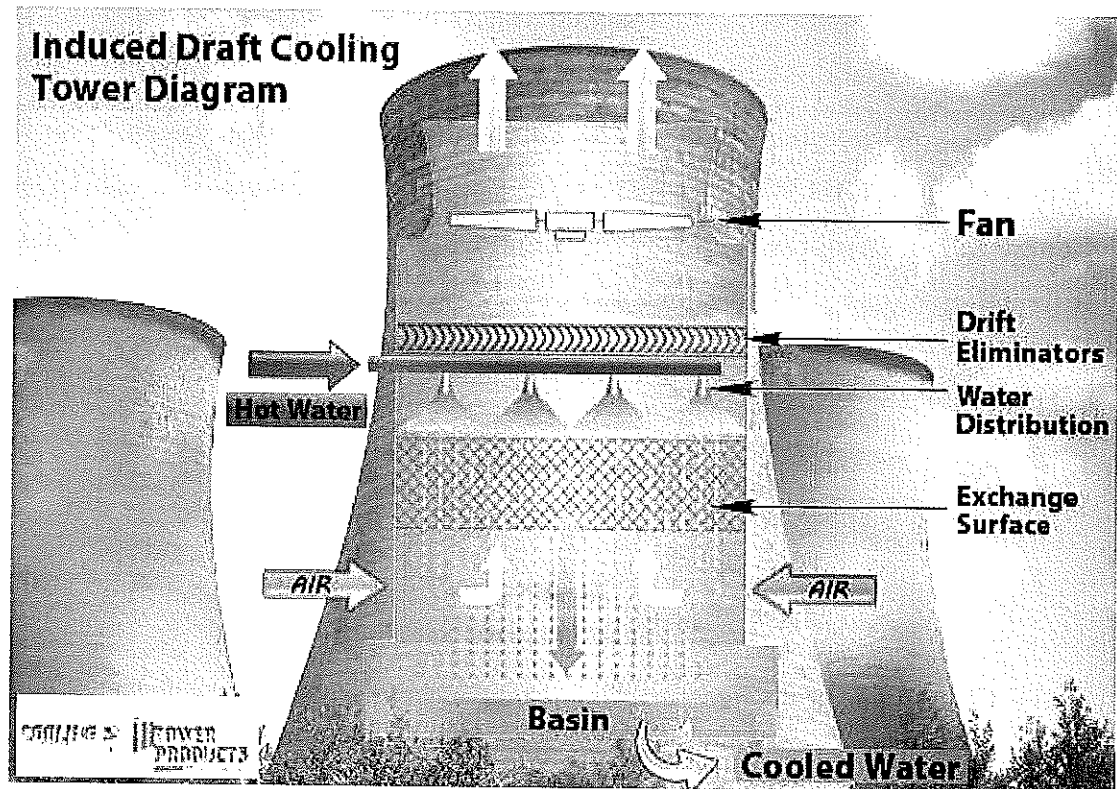

- 3) Flow rate, design or operating pressure, operating temperature, allowable pressure drop, condensing capacity, coolant capacity.



School of HVAC&R Skills

Session: 2019-20 (Summer / Winter Semester)

B. Voc. 3rd Semester,
2nd In-Sem. Examination

Course Code: HVA-1303

Time: 1 Hour

Course Name: Air Distribution

Max. Marks: 20

Answer Key

Section – A

05X01 = 05 Marks

1. B
2. B
3. C
4. D
5. D

Section – B

03X02 = 06 Marks

1. **Duct Liner:**

Rectangular duct, plenums, and return-air boxes may be lined with insulation rather than wrapped. Duct liner is also fiberglass, but it does not have a vapor barrier. Duct liner is glued to the inside of the duct and connected with mechanical fasteners that compress the insulation.

Bubble wrap is a new form of duct insulation. It is similar to the bubble packing material with outer layers of either metalized Mylar or aluminum. Bubble wrap may be used as liner or as duct wrap.

2. **Back draft damper**

- Pneumatic operated damper
- Electrically operated damper
- Fire damper

3. For each space, ASHRAE Standard 62.1 specifies the methods of calculating the required supply ventilation rates and exhaust rates. They are used to determine the amount of cfm that must be exhausted from the space to maintain comfort.

Section – C

03X03 = 09 Marks

1. **Rectangular Ducts:** Rectangular metal ducts must be designed to avoid vibration and structural failure. Vibration can occur when a flat sheet acts as a drum, with the center of the sheet vibrating back and forth.

Round Metal Ducts: Round ducts are inherently strong and rigid, and are generally the most efficient and economical ducts for air systems. The dominant factor in round-duct construction is the ability of the material to withstand the physical abuse of installation and negative pressure

Flexible Ducts: Flexible round duct comes in sizes up to about 24 in. in diameter. Some of it has a reinforced aluminum foil backing and comes in a short box with the duct material compressed. Without the insulation, the duct looks like a coil spring with a flexible foil backing.

2. A fan is an air pump that creates a pressure difference and causes air flow. The fan impeller does work on the air, imparting to it both static and kinetic energy, varying in proportion depending on the fan type. Fans are generally classified as centrifugal fans or axial flow fans according to the direction of air flow through the impeller.

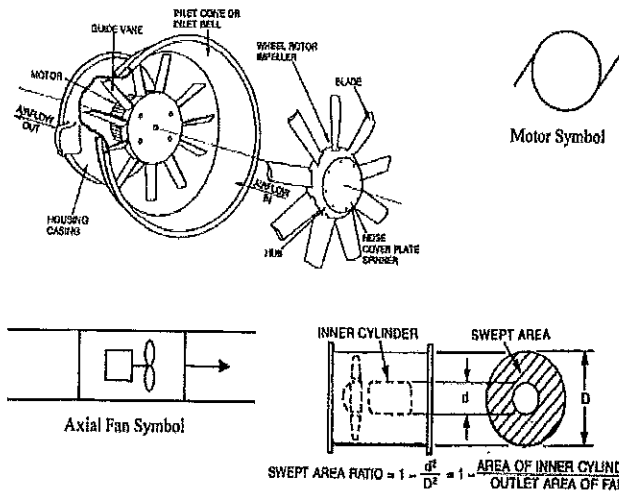

3. Listed below are a few problems caused by leaky ductwork.:

1. Leaks in return ducts draw air into the building from crawl spaces, garages, and attics, bringing with it dust, mold spores, pollen, insulation fibers, and other contaminants.
2. Leaks in supply ducts cause expensive conditioned air to be dumped directly outside, in the attic or crawl space, rather than delivering it to the building.
3. Duct leakage greatly increases the use of electric strip heaters in heat pumps during the heating season.
4. In humid climates, return-air ducts drawing in moist air leaks can overwhelm air-conditioning humidity loads, causing occupants to feel clammy.



BHARTIYA SKILL DEVELOPMENT UNIVERSITY

Registration No.:

School of HVAC&R Skills

Session: 2019-20 (Summer / Winter Semester)

B. Voc. 3rd Semester,

2nd In-Sem. Examination

Course Code: HVA-1303

Course Name: Air Distribution

Instruction: Attempt all questions.

Time: 1 Hour

Max. Marks: 20

Section – A

05X01 = 05 Marks

1. The following is the symbol for _____:
- a) Clothed Duct b) Flexible Duct c) Rigid Duct d) All of the above



2. The minimum total supply of airflow for office applications should be :
- a) 0.05 cfm/ft²
b) 0.06 cfm/ft²
c) 0.6 cfm/ft²
d) 10 cfm
3. The most efficient and economical ducts for air systems are:-
- a) Rectangular
b) Oval
c) Round
d) None of the above
4. Air system design must consider: -
- a) Noise
b) Duct leakage
c) Fire and smoke control
d) All of the above
5. Sound absorbing material can be arranged in a duct system by :-
- a) Lining fan suction and discharge plenums
b) Lining ducts with sound absorbing materials
c) Lining duct sections close to elbows
d) All of the above

Section – B

03X02 = 06 Marks

1. What are the types of duct insulation available?
2. What are different damper types that are used?
3. How does ventilation rates play a role in air distribution?

Section – C

03X03 = 09 Marks

1. What are the different types of ducts available?
2. What are centrifugal and axial fans? Explain with a diagram.
3. What are duct leaks and how do they occur?

Handy.
A



School of RAC Skills

Session: 2019-20 (Summer Semester)

B. Voc. Program, 1st Semester,

2st In-Sem. Examination

Course Code: HVA1304

Course Name: Thermal Insulation

Time: 1 Hour

Max. Marks: 20

Section – A

05X01 = 05 Marks

1. Which Thermal insulating material has PERM rating between 0.1-0.14?
 - a) Elastomeric Foam
 - b) Calcium Silicate
 - c) Mineral Wool
 - d) Cellulosic Fibre

2. Which thermal insulating material has the lowest thermal resistance?
 - a) Calcium Silicate
 - b) Perlite
 - c) Phenolic Foam
 - d) Vermiculite

3. Which insulating material has lowest working temperature?
 - a) Calcium Silicate
 - b) Cellulosic Fibre
 - c) Elastomeric Foam
 - d) Cellular Glass

4. Which thermal insulating material is made of amorphous volcanic glass?
 - a) Perlite
 - b) stone Wool
 - c) Foam Glass
 - d) Glass Wool

5. Which is measuring SI unit of conductance?
 - a) W/M. K
 - b) W/K
 - c) W/M².K
 - d) Btu/ Hr. °F. ft²

Section – B

03X02 = 06 Marks

1. What are PERM and Thermal Conductivity?
2. How corrosiveness and Fire rating effect the thermal insulating materials applications?



3. How natural insulation material were used in ancient time?

Section – C

03X03 = 09 Marks

1. Derive the equation for heat flow through a plane wall, wall is composite of two different material.
2. Write a note on Thermophysical properties of following
 - (a) Perlite
 - (b) Mineral Fibre
3. Classify thermal insulation material on the basis of Generic properties

Enr...
S



School of RAC Skills

Session: 2019-20 (Summer Semester)

B. Voc. Program, 1st Semester,

2st In-Sem. Examination

Course Code: HVA1304

Time: 1 Hour

Course Name: Thermal Insulation

Max. Marks: 20

Section – A

05X01 = 05 Marks

1. (a)
2. (d)
3. (b)
4. (a)
5. (b)

Section – B

03X02 = 06 Marks

Answer 1

1. PERM

By definition, a vapor barrier is a material that has a permeance of 1 "perm" or less. A perm is an English unit equal to 1 grain of vapor transmitted per hour per square foot per inch of mercury difference in vapor pressure; i.e.

$$1 \text{ PERM} = 1 \text{ Grain/ hr ft}^2 \text{ in-Hg}$$

2. Thermal Conductivity

$$Q = k A \Delta T / l$$

where k, the proportionality constant, is commonly known as the thermal conductivity of the material. Examining the equation above reveals that k is a measure of how rapidly heat may be conducted through a unit area and thickness of a material when driven by a 1" temperature difference. If area is given in square feet and thickness in inches, then k has the units of Btu-in/ft²-hr-°F

Answer 2

Corrosiveness and fire rating has grate impact on insulation selection material.

Corrosiveness shows how rapidly fire can catch the insulation material, it also shows probability of fire accident. A material with high fire rating can't be use so easily, it always need a fire retardant coating, that increase it cost and ability

On the other hand Corrosiveness show the degree of reaction with other materials and getting degradation, High corrosiveness shows short life of insulating to prevent it corrosion retarder coating is required

Answer 3



BHARTIYA SKILL DEVELOPMENT UNIVERSITY

In ancient time human start human started to seek for inhabitants, these inhabitants were made of cave either earth shelters.

They need these inhabitants to protection against wild animals, extreme summer, extreme cold, heavy rain and other climate problems.

Animal skin, wool, fur, wood and tree products were first insulating materials as they are natural and organic so these materials has limited life span.

Clothing and shelter were first need as insulation and this was the starting point of history of insulation.

Section – C

03X03 = 09 Marks

Answer 1

Imagine a plane wall is composite of two different material in this case heat transfer will depends upon relative value of thermal conductivity of and thickness of both material.

$$Q = k A (T_1 - T_2) / X = (T_1 - T_2) / (L / k A)$$

for first material

$$(T_1 - T_2) = Q \times (L_1 / k_1 A)$$

For second material

$$(T_2 - T_3) = Q \times (L_2 / k_2 A)$$

if the two equations are added then unknown value T2 will eliminated.

$$(T_1 - T_3) = Q \{ (L_1 / k_1 A) + (L_2 / k_2 A) \}$$

$$(T_1 - T_3) = Q (R_1 + R_2)$$

$$Q = (T_1 - T_3) / (R_1 + R_2)$$

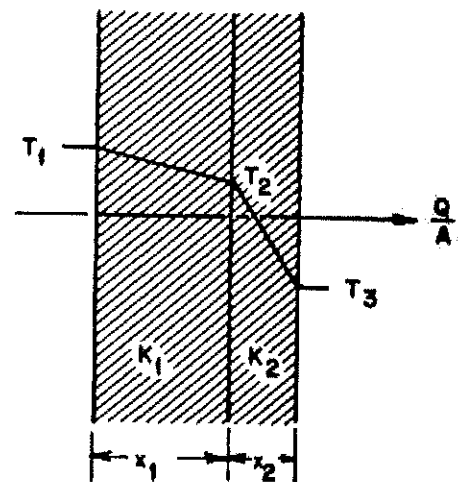

Answer 2

Perlite loose fill insulation is made from siliceous volcanic glass pellets, expanded to between 4 and 20 times their original volume. These pellets contain glass-enclosed dead air spaces.

Density is varied by controlling the perlite to cement ratio, and a range, of 20 to 40 lb/ft³ is typical.

Perlite is used primarily in industrial and commercial buildings as a roof insulation board material. The next most frequent use is in lightweight insulating concrete. Perlite insulating concrete, both preformed and cast-in-place, is used primarily for roof decks, floor slabs, and wall systems. Low density expanded perlite is used as a loose fill insulation.

	Batt	Loose Insulation
k	0.27	0.38
R-Value	3.62	2.63
Density	5	10



BHARTIYA SKILL DEVELOPMENT UNIVERSITY

PERM	high	high
Cp	0.20	0.20
Corrosion	NONE	NONE
Maximum Service temperature	370	1000

Mineral fiber is made from rock or slag; therefore, the base material is non-combustible and its melting point is above 1200°C. However, binders added to the wool may be flammable. The flame spread rating of this material is reported to be less than 25 when tested according to ASTM-84.

Asphalt coated or foil-laminated kraft paper may be used as a vapor retardant facing on batts. Because these facings are flammable, they should be protected from open flames or high temperatures. Burning of facings or organic binders could produce toxic vapors. Thermal conductivity is affected by moisture content, but the change is transient and the material returns to its original properties upon drying. Mineral fiber boards are used primarily in roofing insulation, as a building sheath material, and other industrial applications.

	Batt	Loose Insulation	Bonded
k	3.23	3.10	0.28
U-Value	0.31	0.32	0.28
Density	2	1.7	9 to 11
PERM	high	high	high
Cp	0.20	0.20	0.20
Corrosion	NONE	NONE	NONE
Maximum Service temperature	370	1000	400

Answer 3

o Air film or air layers.: Air films or air layers may be composed simply of a single surface, or possibly of multiple surfaces between which only air exists. Resistance to heat flow is exhibited by surfaces utilizing surface film resistance, as well as by the layers of air as a result of conduction or convection across the layers.

o Closed cellular material.: Cellular insulation is composed of parent material containing many small voids of air or gas. Usually, this material is of the closed cell variety, where each cell is separated from the others by cell windows or thin membranes. Cellular insulation is produced from glass, plastics, and rubber. Common generic thermal insulations of this type are cellular glass, expanded elastomeric foam, polystyrene foam, polyisocyanurate and polyurethane foams, and urea-formaldehyde foam.

o Fibrous materials.: Fibrous insulation is composed of many small-diameter fibres. These fibres may be made from organic materials such as hair, wood, and cane, or may be made from synthetic materials such as glass, rock wool, slag wool, aluminium silicate, asbestos, and carbon.



BHARTIYA SKILL DEVELOPMENT UNIVERSITY

Flake materials.: Flake insulation is composed of small particles. These particles, or flakes, may be poured into an air space or bonded together to provide a rigid form of the insulation. Rigid form flake insulation can be used for pipe insulation or for other applications in block or board form. The two types of flake insulation commonly used are perlite and vermiculite.

o Granular materials.: Granular insulation is composed of small particles which contain voids or hollow spaces. These hollow spaces can transfer air between the individual voids. The parent material can be magnesia, calcium silicate, earth, or vegetable cork. The first three are commonly used as industrial piping insula

o Reflective foils.: Reflective foil insulation is composed of parallel thin sheets of foil with either high thermal reflectance or low emittance. These thin sheets are spaced to reflect radiant heat back to the source. Each separate sheet provides two heat transfer film coefficients; the air space between two sheets causes a reduction in conduction and convection.

**BHARTIYA SKILL DEVELOPMENT UNIVERSITY**

School of HVAC & R Skills
Session: 2019-20 (Summer Semester)
B. Voc. Program, 3rd Semester,
2nd In-Sem. Examination

Course Code: HVA 1305**Time: 1 Hour****Course Name: Electrical and Electronics Safety Testing****Max. Marks: 20**

Instruction: Answer all questions from section A, each question carries one mark. Answer all questions from section B, each question carries two marks. Answer all questions from section C, each question carries three marks. Scientific calculator is allowed.

Section – A

05X01 = 05 Marks

- Smoke detectors to be located on:
(a) Ceiling of the fire risk zone (b) Ground floor
(c) Walls of risk zone (d) Windows
- National Fire Service Day is being observed every year on:
(a) 9th October (b) 14th March (c) 14th September (d) 14th April
- Fire Service Week is observed nation-wide during:
(a) 14th March to 20th March (b) 14th April to 20th April
(c) 14th Sept. to 20th Sept. (d) 9th October to 20th October
- Fire prevention day is being observed every year on:
(a) 12th August (b) 14th April (c) 9th October (d) 5th September
- Fire prevention week is being observed every year:
(a) On Sunday through Saturday period in which October 9th
(b) On Monday through Sunday period in which October 9th
(c) On Thursday through Wednesday period in which October 9th
(d) On Saturday through Sunday period in which October 9th

Section – B

03X02 = 06 Marks

- What are the features of total fire protection systems?
- What is the purpose of fire-fighting?
- What precautions to be taken to prevent spreading of fire in cable trenches?

Section – C

03X03 = 09 Marks

- What do you understand by passive and active fire safety system?
- What are design requirements for fire safety of transformers?
- What requirements are mandatory for certifying the fire-fighting readiness at the plant?

H. A. H. H.
5/11/19

Set - A.



BHARTIYA SKILL DEVELOPMENT UNIVERSITY

School of HVAC & R Skills
Session: 2019-20 (Summer Semester)
B. Voc. Program, 3rd Semester,
2nd In-Sem. Examination

Course Code: HVA 1305

Course Name: Electrical and Electronics Safety Testing

Time: 1 Hour

Max. Marks: 20

Section – A

05X01 = 05 Marks

1. (a)
2. (d)
3. (b)
4. (c)
5. (a)

Section – B

03X02 = 06 Marks

Q.1. What are the features of total fire protection systems?

Ans. (i) Fire detection system

(ii) Fire alarm system

(iii) Fire Alarm & control system

(iv) Fire hydrant system

(v) Monitoring system

Q.2. What is the purpose of fire-fighting?

Ans. (i) Extinguishing fire

(ii) Stopping spreading of fire and smoke or poisonous gases.

(iii) Saving life

(iv) Saving property and

(v) Minimizing the risk to adjoined buildings and premises

Q.3. What precautions to be taken to prevent spreading of fire in cable trenches?

Ans. (i) Fire barriers should be installed in cable trenches at periodical intervals.

(ii) All cable outlet points in trench must be sealed with fire resisting materials.

Section – C

03X03 = 09 Marks

1. What do you understand by passive and active fire safety system?





BHARTIYA SKILL DEVELOPMENT UNIVERSITY

Ans. Passive fire safety systems are fire barriers, fire seals, fire detectors and fire retardant paints. Active fire safety systems are pumps, fire hydrants sprinkles and extinguishers.

2. What are design requirements for fire safety of transformers?

Ans. Transformers installed inside fire areas containing system importance to the safety should be of dry type or insulated and cooled with noncombustible liquid.

(ii) Transformers filled with combustible fluid that are located inside indoors should be enclosed in transformer vault.

(iii) Outdoor oil filled transformers should have oil spill confinement features or drainage away from the buildings.

(iv) Transformers shall be protected by automatic high velocity water spray system or by carbon dioxide.

3. What requirements are mandatory for certifying the fire-fighting readiness at the plant?

Ans. The following requirements are mandatory for certifying the fire-fighting readiness at the plant.

- (i) Premises are safe
- (ii) Escape routes, stair cases,
- (iii) Portable fire extinguishers, sand buckets have been placed as required.
- (iv) Fire prevention boards have been displayed.
- (v) Personnel have been trained.
- (vi) Rehearsals of activities (in the event of fire) are carries out.
- (vii) Fixed type fire-fighting systems have been installed, tested and commissioned.
- (viii) Insurance team has inspected the Plant and conveyed approval of fire-fighting facilities and safety provisions.

Set - A