



School of Refrigeration & Air Conditioning Skills

Session: 2021-22 (Summer Semester)

B. Voc. Program, III Semester,

End-Sem. Examination

Course Code: RAC1301

Time: 2 Hours

Course Name: Psychrometry and System Design

Max. Marks: 50

Instruction:

All questions are compulsory.

SET-A

Section – A

10X01 = 10 Marks

1. Refrigerant the working fluid used for absorbing and _____ heat in a refrigeration system?
a) Releasing b) Increasing c) Decreasing d) None
2. With the increase in pressure, the temperature:
a) Decreases b) Increases c) remains constant d) None
3. R-22 is what type of refrigerant?
a) Inorganic b) Saturated c) Mixture d) None
4. What value of RH is considered as a comfort condition?
a) 50% b) 40% c) 70% d) None
5. What is the mathematical representation for the refrigerant $C_2H_2F_4$?
a) R134a b) R152 c) R22 d) None
6. Which refrigerant is better in view of GWP?
a) R134a b) R152 c) CO_2 d) None
7. The rate of body heat loss is affected by-
a) Air Temperature b) Air humidity
c) Clothing d) All of the above
8. The relative humidity in winter is ----- than in summer season.
a) Less b) More
c) Equal d) All of the above
9. Which of the following doesn't add to latent load in a room?
a) People b) Infiltration
c) Lighting d) None
10. What is the full form of COP?
a) Coefficient of performance b) Correspondence of performance
c) Convection of performance d) None



BHARTIYA SKILL DEVELOPMENT UNIVERSITY

Section – B

04X04 = 16 Marks

1. What is a refrigerant? Write down the classification of refrigerants.
2. What is the difference between transmission gain and solar gain?
3. How do you calculate performance of a system? Explain in detail
4. Explain:

Dry bulb temperature

Humidity Ratio

Wet Bulb temperature

Dew Point temperature

Section – C

04X06 = 24 Marks

1. What is the advantage of inverter compressors over the standard ones?
2. What is thermal comfort and how do you design a system taking it into consideration?
3. What is Dehumidified CFM and why is it important?
4. What are some thermodynamic properties of a refrigerant?



BHARTIYA SKILL DEVELOPMENT UNIVERSITY

Registration No.:

School of Refrigeration & Air Conditioning Skills

Session: 2019-20 (Summer Semester)

B. Voc. Program, III Semester,

End-Sem. Examination

Course Code: RAC1301

Time: 2 Hours

Course Name: Psychrometry and System Design

Max. Marks: 50

Instruction:

All questions are compulsory.

SET-A

Section – A

10X01 = 10 Marks

1. D
2. B
3. B
4. A
5. A
6. D
7. D
8. B
9. C
10. A

Section – B

04X04 = 16 Marks

1. A refrigerant is a working fluid used in the refrigeration cycle of air conditioning systems and heat pumps where in most cases they undergo a repeated phase transition from a liquid to a gas and back again. Classifications are class 1, for refrigerants that do not propagate a flame when tested as per the standard; class 2, for refrigerants of lower flammability; and class 3, for highly flammable refrigerants such as the hydrocarbons.
2. Transmission gain is associated with walls and windows which are not solar exposed and thus does not contribute in the solar gain of the system. Solar gain on the other hand is for the glass and walls which are exposed to the direct sunlight.
3. The coefficient of performance or COP (sometimes CP or CoP) of a heat pump, refrigerator or air conditioning system is a ratio of useful heating or cooling provided to work (energy) required. Higher COPs equate to higher efficiency, lower energy (power) consumption and thus lower operating costs.
4. The Dry Bulb temperature, usually referred to as air temperature, is the air property that is most common used. When people refer to the temperature of the air, they are normally referring to its dry bulb temperature. The **Wet Bulb** temperature is the temperature of adiabatic saturation. This is the temperature indicated by a moistened thermometer bulb exposed to the air flow. The **Dew Point** is the temperature at which water vapor starts to



BHARTIYA SKILL DEVELOPMENT UNIVERSITY

condense out of the air, the temperature at which air becomes completely saturated. Above this temperature the moisture will stay in the air. Humidity ratio is normally expressed in kilograms (or pounds) of water vapor per kilogram (or pound) of dry air.

Section – C

04X06 = 24 Marks

1. Compared to a regular compressor, an inverter compressor has several benefits:
Energy efficiency. As opposed to a regular compressor, the inverter compressor runs more consistently and at controlled speeds, which means it uses significantly less energy.
Durability. Compressors experience the most wear and tear during the start up period. Inverter compressors start up slowly, thereby reducing a chance of failure.
Freshness. Because the inverter compressor doesn't stop completely, only slows down, the temperature in the refrigerator is more constant, which means better storage conditions for your food.
Quiet operation. Due to its constant operation an inverter compressor also produces less noise.

2. Thermal comfort is very difficult to define as you need to take into account a range of environmental, work-related and personal factors when deciding what makes a comfortable workplace temperature. The best that you can realistically hope to achieve is a thermal environment that satisfies the majority of people in the workplace. Thermal comfort is not measured by room temperature, but by the number of employees complaining of thermal discomfort. To better understand why room temperature alone is not a valid indicator of thermal comfort, see the six basic factors.

3. That sensible load will define how much air you need for the cooling (or what the load sheets call Dehumidified CFM) So you work out the dehumidified air flow from the room sensible load. This gives you your CFM and your required supply dry bulb and wet bulb. Dehumidifiers work in one of two ways—by refrigeration (cooling air to remove moisture using similar technology to a refrigerator or air conditioner) or by absorption/adsorption (where moisture is absorbed into or adsorbed onto a drying material and then removed). We'll look at each of these in turn. While air conditioners throw cool air into the room, dehumidifiers pull out moisture from the air. This is where a dehumidifier is more efficient; it can remove a high amount of moisture from the room. While the room may naturally drop when humidity is removed, dehumidifiers do not throw any cool air into a room.

4. Critical Temperature and Pressure

The critical temperature of the refrigerant should be as high as possible above the condensing temperature in order to have a greater heat transfer at a constant temperature. If this is not taken care of, then we will have excessive power consumption by the refrigeration system.

Specific Heat

The specific heat of the liquid should be as small as possible. This ensures that the irreversibilities associated with throttling are small and there is greater subcooling of the liquid. On the other hand, the specific heat of vapor should be high to have less superheating of the vapor.

Enthalpy of Vaporization

This should be as large as possible to minimize the area under superheat and the area reduction due to throttling. Also, the higher value of enthalpy of vaporization lowers the required flow rate per ton of refrigeration.



BHARTIYA SKILL DEVELOPMENT UNIVERSITY

Registration No.:

School of Refrigeration & Air Conditioning Skills

Session: 2021-22 (Summer Semester)

B. Voc. Program, III Semester,

End-Sem. Examination

Course Code: RAC1301

Time: 2 Hours

Course Name: Psychrometry and System Design

Max. Marks: 50

Instruction:

All questions are compulsory.

SET-B

Section – A

10X01 = 10 Marks

1. Refrigerant the working fluid used for _____ and releasing heat in a refrigeration system?
a) Absorbing b) Increasing c) Decreasing d) None
2. Chemical Stability of refrigerant means:
a) Inertness b) Reactive ness c) Flammability d) None
3. A refrigerant should not be?
a) Toxic b) Flammable c) Reactive d) None
4. What value of DB is considered as comfort condition?
a) 92°F b) 98 °F c) 102 °F d) 106°F
5. How is efficiency calculated?
a) COP X 1000 b) 1/COP c) COPx100 d) None
6. Which refrigerant has a trans critical cycle
a) R134a b) R152 c) CO₂ d) None
7. The unit for thermal resistance of clothes is-
a) Clo b) Joules
c) BTU d) All of the above
8. The relative humidity summer is ----- than in winter season.
a) Less b) More
c) Equal d) All of the above
9. Which of the following doesn't add to sensible load in a room?
a) People b) Infiltration
c) Lighting d) None
10. What is the full form of COP?
a) Coefficient of performance b) Correspondence of performance
c) Convection of performance d) None



BHARTIYA SKILL DEVELOPMENT UNIVERSITY

Section – B

04X04 = 16 Marks

1. Explain the difference between CFC, HFC and HCFC.
2. What are ventilation rates and why is it calculated?
3. Explain the nomenclature of R-22
4. Explain:

Specific Heat

Specific Volume

Dew Point Temperature

Relative Humidity

Section – C

04X06 = 24 Marks

1. What are VRV/VRFs and what is their working mechanism?
2. Explain ODP and GWP in detail?
3. What are the proper ways to handle any refrigerant?
4. What are some chemical properties of a refrigerant?



School of Refrigeration & Air Conditioning Skills

Session: 2019-20 (Summer Semester)

B. Voc. Program, III Semester,

End-Sem. Examination

Course Code: RAC1301

Time: 2 Hours

Course Name: Psychrometry and System Design

Max. Marks: 50

Instruction:

All questions are compulsory.

SET-B

Section – A

10X01 = 10 Marks

1. B
2. A
3. B
4. B
5. A
6. C
7. C
8. B
9. A
10. A

Section – B

04X04 = 16 Marks

1. Chlorofluorocarbons (CFCs), hydrochlorofluorocarbons (HCFCs) and halons destroy the earth's protective ozone layer, which shields the earth from harmful ultraviolet (UV-B) rays generated from the sun. CFCs and HCFCs also warm the lower atmosphere of the earth, changing global climate. Hydrofluorocarbons (HFCs) also act to warm the planet. The Minnesota Pollution Control Agency (MPCA) is working with industry, residents and government to reduce the damage done to the ozone layer and global climate by CFCs, HCFCs, HFCs and related chemicals.

2. The ventilation rate of a building, Q , is usually defined as the rate at which external air (fresh air) flows into the building. The qualitative characteristics of a natural ventilation system can be seen by plotting Q against wind speed, U .

3. $X = 0 \Rightarrow$ No. of Carbon atoms = $0+1 = 1 \Rightarrow$ derivative of methane (CH_4)

❖ $Y = 2 \Rightarrow$ No. of Hydrogen atoms = $2-1 = 1$

❖ $Z = 2 \Rightarrow$ No. of Fluorine atoms = 2

❖ The balance = $4 - \text{no. of (H+F) atoms} = 4-1-2 = 1 \Rightarrow$ No. of Chlorine atoms = 1

\therefore The chemical formula of R 22 = CHClF_2



BHARTIYA SKILL DEVELOPMENT UNIVERSITY

The quantity of heat required to raise the temperature of one gram of a substance by one Celsius degree. The units of specific heat are usually calories or joules per gram per Celsius degree. Specific volume is a property of materials, defined as the number of cubic meters occupied by one kilogram of a particular substance. The dew point is the temperature below which the water vapour in a volume of air at a constant pressure will condense into liquid water. Relative humidity is the amount of water vapor actually in the air, expressed as a percentage of the maximum amount of water vapor the air can hold at the same temperature

Section – C

04X06 = 24 Marks

1. It's a very sophisticated technological air conditioning system, based on several principles:

Refrigerant only – where refrigerant is the only coolant material in the system (in contrary to the chilled water systems, where refrigerant is used for cooling/heating the water that is circulated throughout the whole system)

Inverter compressors that allow lowering power consumption with partial cooling/heating loads

Several air handlers (indoor units) on the same refrigerant loop/circuit

Ability of modular expansion (especially applicable for large projects, that can grow in stages)

2. ODP values range from 0 to 1: the closest the ODP value is to 1, the more harmful the refrigerant is for the ozone layer. CFCs are generally characterised by a big ODP value, because they contain chlorine, which is accused of heavily contributing to the **Ozone Depletion** phenomenon. As a result, CFCs have been phased out of use nowadays. Global Warming Potential is a measure of the relative greenhouse gas effect caused by the release of a gaseous chemical into our atmosphere. Greenhouse gases act as a blanket in our atmosphere trapping heat. Carbon Dioxide is used as a reference gas and is assigned a value of 1.0. For example, let's look at R410A. This gas was introduced to replace the use of ozone depleting R22 in air conditioning applications. R410A has a GWP of 1924. This means every kilogram of R410A released into our atmosphere is equivalent to releasing 1924 kilograms of carbon dioxide!

3. The following guidelines should be followed when working with or around refrigerants:

- Always read the product label and the product Material Safety Data Sheet (MSDS);
- Always use with adequate ventilation. Most fatal accidents involving refrigerant are due to oxygen deprivation;
- Never expose refrigerants to flames, sparks or hot surfaces;
- Never trap liquid refrigerants between valves where there is no pressure relief device. A dirty pressure relief device must be replaced;
- Use an alcohol spray to clean refrigerant sight glasses that have become coated with ice;
- When leak testing a system, use nitrogen for increasing the pressure after the refrigerant is recovered. Use a pressure regulator on the nitrogen cylinder to ensure a safe pressure in the system. The low-side test pressure value listed on the data plate should be used as the maximum pressure applied to the system for leak testing;



4. Chemical Stability and Inertness

It should be chemically stable for the operating ranges of temperature. Also, it should not react with the materials of the refrigeration system or with which it comes into contact.

Flammability

The refrigerant should be inert and not catch fire when subjected to high temperatures. From this viewpoint CO₂ is the most suitable as it is not only non-flammable, but also acts as a fire-extinguisher. Ethane, butane, isobutene are highly undesirable as they catch fire quickly.

Effect on Oil

The refrigerant should not react with the lubricating oil else, there is a possibility of loss of lubricating action due to either thickening or thinning of the oil. It should not be soluble in the oil else there will be reduction in the viscosity of the lubricating oil.





School of Refrigeration & Air conditioning Skills
Session: 2021-22 (Summer Semester)
B. Voc. Program, V Semester,
End Sem. Examination

Course Code: RAC1302

Time: 1 Hour

Course Name: Central AC Systems

Max. Marks: 50

1. **Instruction:** Answer all questions from section A, each question carries one mark.
2. Answer all questions from section B, each question carries four mark.
3. Answer all questions from section C, each question carries six mark.
4. Use of Calculator is allowed

Section – A

10 X 01 = 10 Marks

05 objective type questions, each question carries 01 mark.

Q1. _____ fan is used in parking Ventilation?

- a) Ram b) Jet
c) Board d) coaxial

Q2. Which lines in psychometric shows dry bulb

- a. Horizontal lines b. vertical lines
c. Lines on curve left d. enthalpy lines

Q3. Psychometric is the study of _____?

- a. Moist air b. Dry air
c. Dew point air d. None of these

Q4. Chiller are _____ & _____ cooled?

- a. Air & water b. dry & wet
c. Moist & Vapor d. pressure vs Enthalpy

Q5. Ventilation through fan, blower is classified as

- a. forced b. draught
c. crossed d. stacked

Q6. Making decisions about when to turn chillers on and off is commonly referred to as chiller?

- a) Sequencing b) Alternative
c) Throttling d) Lagging

Q7. In a pychometry _____ is measured?

- a) Water % b) Moisture in Air
c) Moisture and its impact on temperature d) Relative Humidity 50 %

Q8. An _____ in the condenser approach temperature (that is, the temperature difference between the water and the refrigerant inside the condenser)?

- a) Increase b) Decrease
c) Remain constant d) Rate of change

Q9. Condenser are designed according to _____?

- a) Dry & wet b) Fin & tube
c) Tube in tube d) None of the above

Q10. In a pressure duct class 2 will be having _____ "W.C.?"

- a) 1/2" - 3/4" b) 3/4" - 6 1/2"
c) 5/4" - 7/4" d) None of the above



BHARTIYA SKILL DEVELOPMENT UNIVERSITY

Section – B

04X04 = 16 Marks

03 short answer type questions, each question carries 04 marks.

Q11. Draw and label types of ventilation?

Q12. Difference between F.CU and A.H.U List any three?

Q13. Types of evaporator used in chillers with diagram?

Q14. What are the types of Artificial ventilation?

Section – C

06X04 = 24 Marks

03 Essay type questions, each question carries 06 marks.

Q15. Name the Types of fitting in a duct along with their application? Draw and label

Q16. With a neat diagram explain the Screw compressor & it's working

Q17. a) Design duct with question 18 and mention the size with Rectangular calculations?

b) For given find the parameter in psychrometry table

WBT	DBT	DPT	RH
50	65		
35			40
30		70	

Q18) Calculate the required CFM and design the Duct for given building? Height to take 10.'

1) CFM of air required. 2) Line diagram for duct design using EFM

DUCT	CFM	VELOCITY	PRESSURE AT	Square size duct(eq.diameter)
Room 1	200		0.08"	
Room 2	500		0.08"	
Room 3	600		0.08"	

Note for Q18: ROOM Dimension 12X12 FT,14X10,12X10

Take NACPH as 4,5,6

DRAW duct run – in answer copies

The Engineering Tool Box

www.EngineeringToolBox.com

PSYCHROMETRIC CHART
 BAROMETRIC PRESSURE 29.921 inches of Mercury

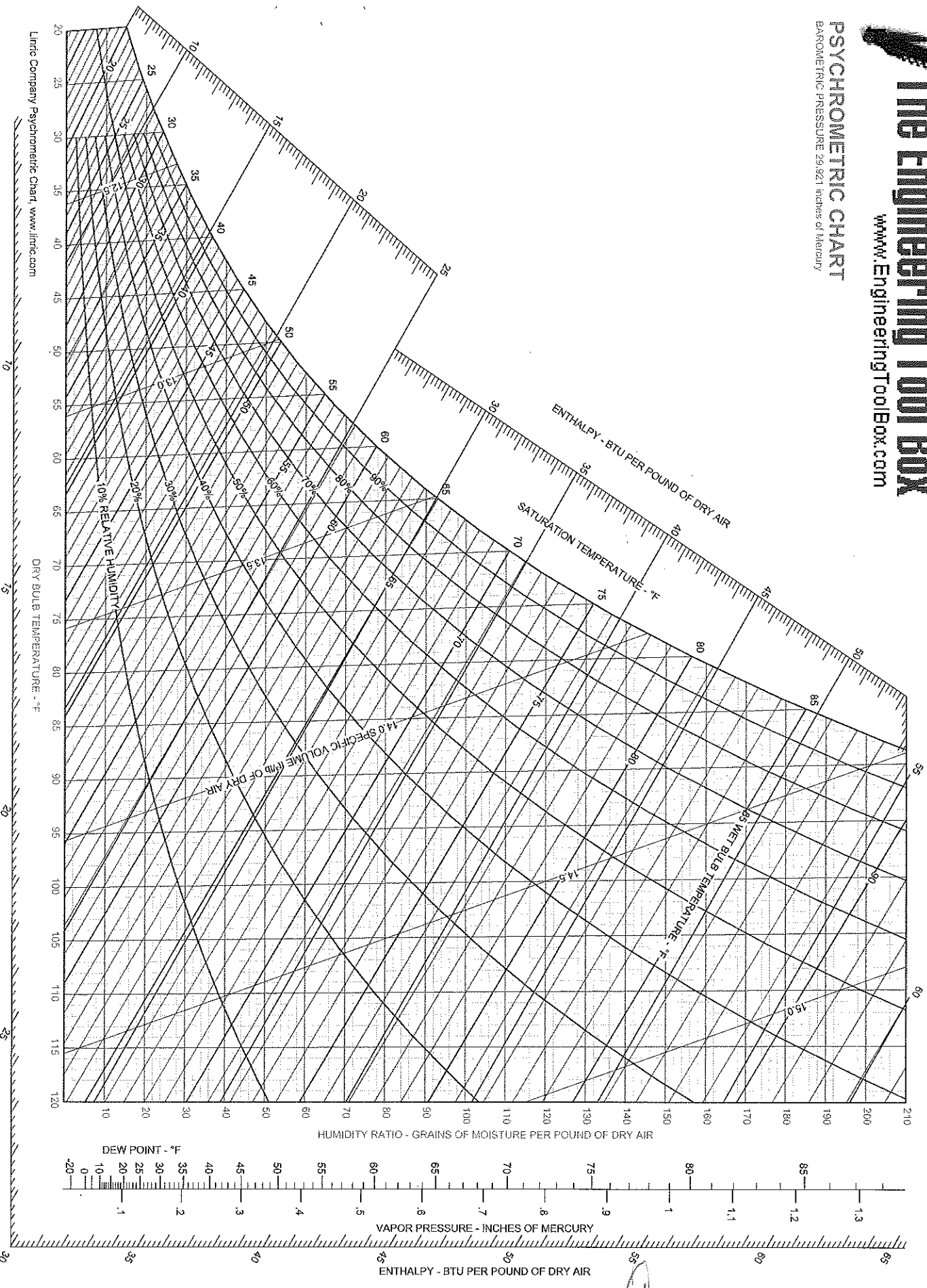

Linde Company Psychrometric Chart, www.linde.com

School of Refrigeration & Air conditioning Skills
Session: 2021-22 (Summer Semester)
B. Voc. Program, V Semester,
End Sem. Examination

Course Code: RAC1302

Time: 1 Hour

Course Name: Central AC Systems

Max. Marks: 50

1. **Instruction:** Answer all Questions from section A, each Question carries one mark.
2. Answer all Questions from section B, each Question carries four mark.
3. Answer all Questions from section C, each Question carries six mark.
4. Use of Calculator is allowed

Section – A

10 X 01 = 10 Marks

- A1. a) Ram
- A2. b. vertical lines
- A3. a. Moist air
- A4. a. Air & water
- A5. a. Forced
- A6. a) Sequencing
- A7. c) Moisture and its impact on temperature
- A8. a) Increase
- A9. a) Dry & wet
- A10.b) 3 ¼" - 6 ½"

Section – B

04X04 = 16 Marks

A11.

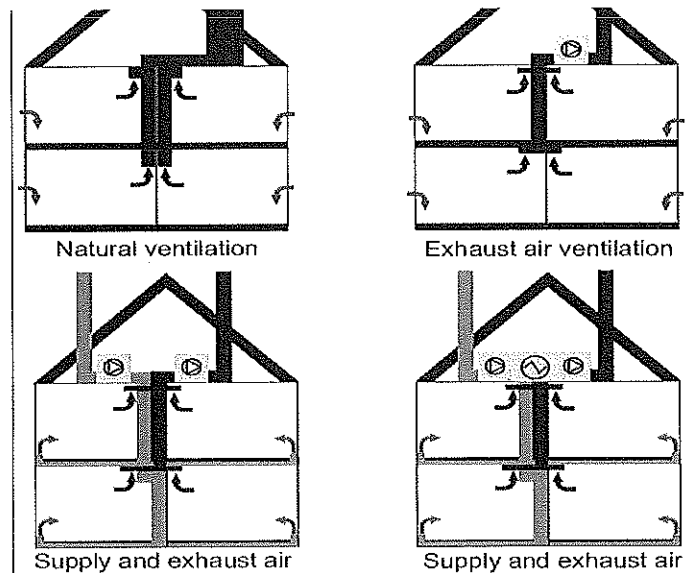

A12. Difference between F.C.U and A.H.U List any three?

F.C.U	A.H.U
SMALL SIZE	BIGGER SIZE
Can be used in direct and indirect cooling	Only indirect
Parameters cannot be handle such as Oxygen circulation and exhaust	Parameters can be handle such as Oxygen circulation and exhaust

A13.

Shell Type-Used where the load is low with space constrain spiral tube in form of coil is shaped to cool the secondary refrigerant

2. Plate heat exchanger type- here two concentric plates are sandwiched between the tube where aluminum plates used as a fin to increase area for heat transfer

3. Flooded shell and tube- here tubes carry refrigerant or secondary refrigerant and as per the application shell part are exposed to these number of tubes for better heat transfer coefficient.

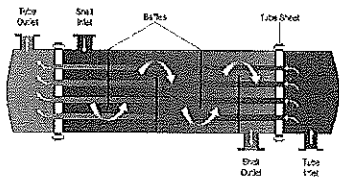
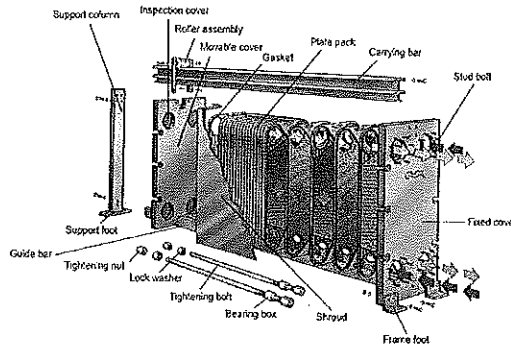
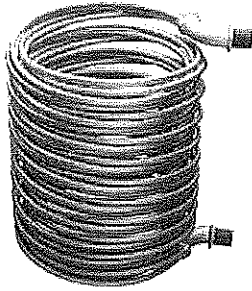

A14. Artificial ventilation

1. Mechanical Ventilation 2. Hydraulic Ventilation 3. Positive Ventilation 4. Horizontal ventilation

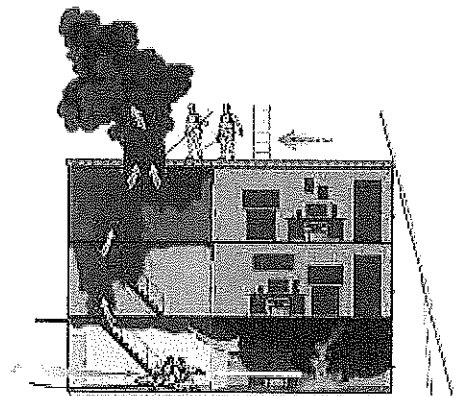
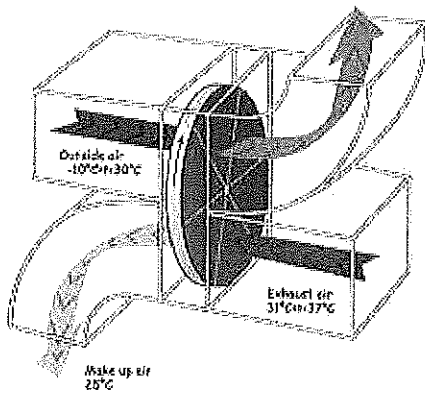

Section – C

06X04 = 24 Marks

A15. Name the Types of fitting in a duct along with their application? Draw and label

Name of fittings	Types	Application
Tee	Single tee, double tee	To provide A 2way or 4 way flow
Shoe piece	Equal unequal	Used for sharp turn and damping air
Elbows	30,45,60,90	For a single way turn in uni-direction
Trouser	Three-way, two way trouser	Used for air direction and duct to duct joint with different directions.
Mitter elbow	15,30,45	For higher angle joints sharp turns
Reducer	Duct width (equal ,unequal)	Large to Small duct
Enlarger	Duct width (equal ,unequal)	Small to larger duct

A16. With a neat diagram explain the Screw compressor & it's working

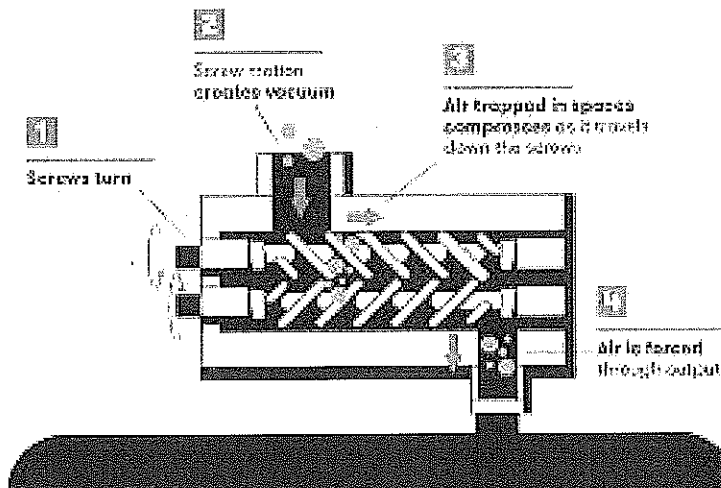

The basic principle of a screw compressor is as the male and female rotors are **rotating in opposite direction they draw air in between them**. As the air progresses along the rotors the air is compressed as the volume space between the rotors decreases, hence creating compressed air that is displace to the outlet.

A17. a) Design duct with question 18 and mention the size with Rectangular calculations?
 b) For given find the parameter in psychrometry table

WBT	DBT	DPT	RH
50	65	49.98	100%
35	25	10	40
30	86	70	100%

A18) Calculate the required CFM and design the Duct for given building? Height to take 10.'

1) CFM of air required 2) Line diagram for duct design using EFM

DUCT	CFM	VELOCITY	PRESSURE AT	Square size duct(eA.diameter)
Room 1	200	600	0.08"	8"
Room 2	500	750	0.08"	12"
Room 3	600	800	0.08"	12.5"



BHARTIYA SKILL DEVELOPMENT UNIVERSITY

Note for A18: ROOM Dimension 12X12 FT,14X10,12X10
Take NACPH as 4,5,6

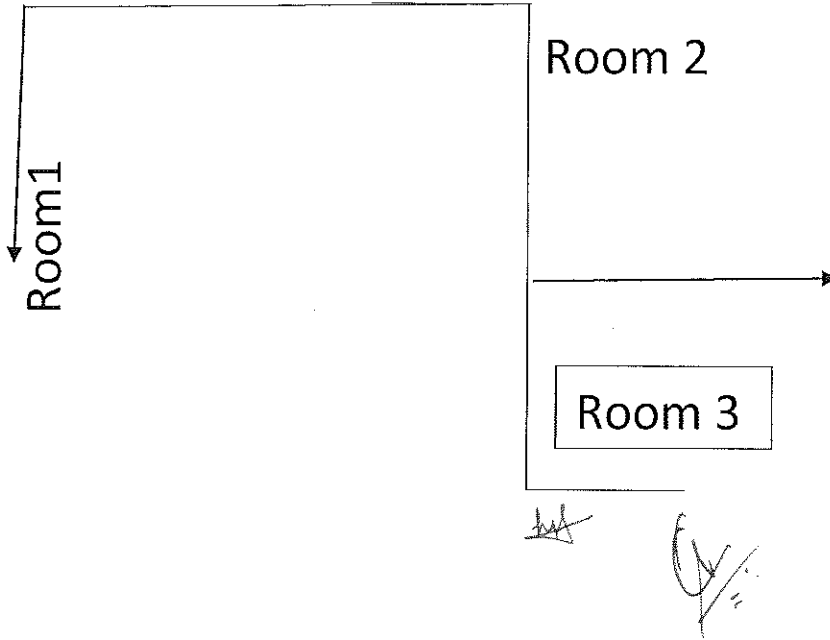



School of Refrigeration & Air conditioning Skills

Session: 2021-22 (Summer Semester)

B. Voc. Program, V Semester,

End Sem. Examination

Course Code: RAC1302

Time: 1 Hour

Course Name: Central AC System

Max. Marks: 50

1. **Instruction:** Answer all questions from section A, each question carries one mark.
2. Answer all questions from section B, each question carries four mark.
3. Answer all questions from section C, each question carries six mark.
4. Use of Calculator is allowed

Section – A

10 X 01 = 10 Marks

05 objective type questions, each question carries 01 mark.

Q1.b) Jet

Q2. a) Back draft

Q3. Chiller can be classified based on application as _____?

a) Process & Comfort Chiller

Q4. Fire dampers are certified by?

a) Under writer's laboratory

Q5. To select a filter _____ is most critical parameter?

a) Ppm (Parts per Million) b) Pressure drop

c) Discharge d) All of the above

A6a) Sequencing

A7. c) Moisture and its impact on temperature

A8. a) Increase

A9. a) Dry & wet

A10. b) $3\frac{1}{2}''-6\frac{1}{2}''$

Section – B

04X04 = 16 Marks

03 short answer type questions, each question carries 04 marks.

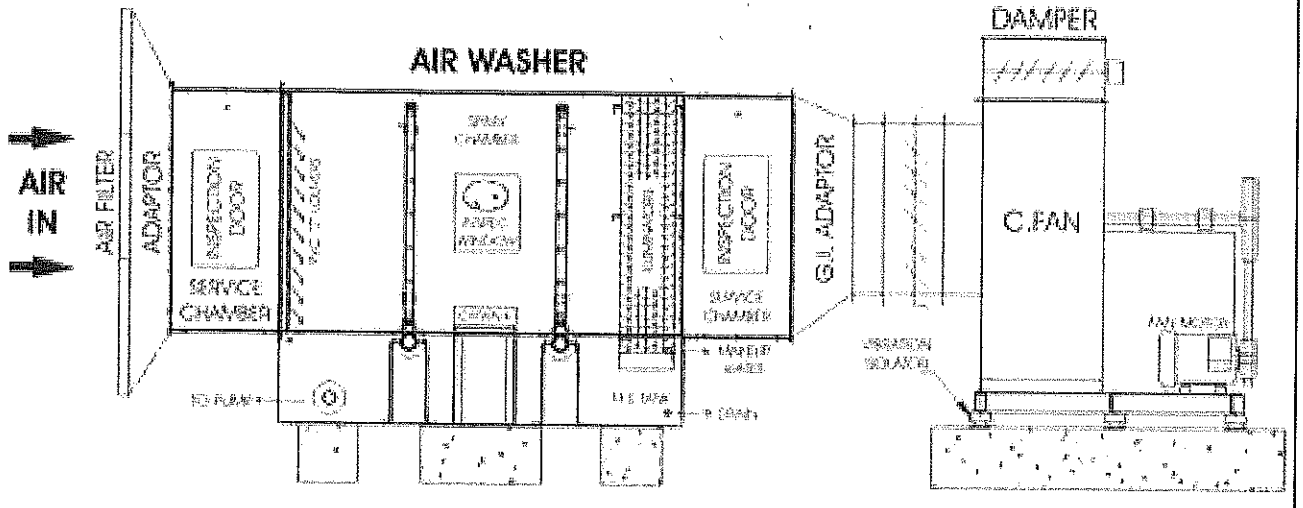

A12. Difference between F.C.U and A.H.U List any three?

F.C.U	A.H.U
SMALL SIZE	BIGGER SIZE
CAN be used in direct and indirect cooling	Only indirect
Parameters cannot be handle such as Oxygen circulation and exhaust	Parameters can be handle such as Oxygen circulation and exhaust

A13.Types of evaporator used in chillers with diagram?

Shell Type-Used where the load is low with space constrain spiral tube in form of coil is shaped to cool the secondary refrigerant

2.Plate heat exchanger type- here two concentric plates are sandwiched between the tube where aluminum plates used as a fin to increase area for heat transfer

3.Flooded shell and tube- here tubes carry refrigerant or secondary refrigerant and as per the application shell part are exposed to these number of tubes for better heat transfer coefficient.

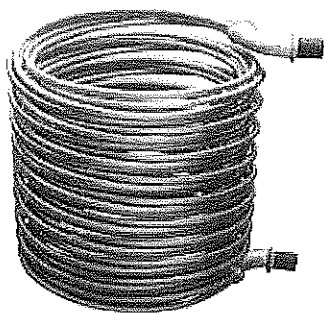

A14.

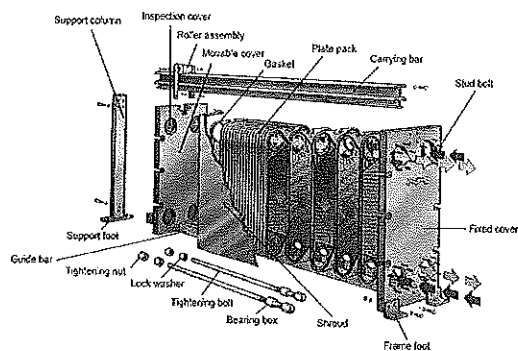

Common Chiller Problems and Possible Causes?

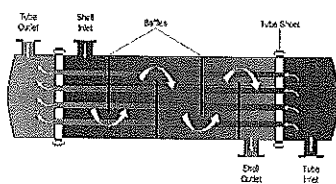

Section – C

06X04 = 24 Marks

03 Essay type questions, each question carries 06 marks.

A15.



Q16. With a neat diagram explain the Scroll compressor & it's working

A16

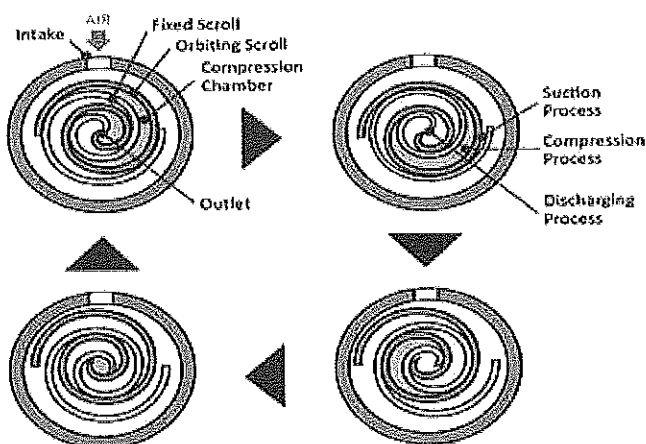

Change in area compressor compress to pressure volume work.

Q17. Using the continuity equation calculate the sizes of duct?

Take $Q=AV$ where Q/V as constant

1) 36 sq. ft. - 6'X6' 2) 169 sq. inches 13"X13" equivalent rectangular sizes?

3) 441 sq. ft. - 21'X21' - 24X16 4) 900 sq. in. 30X30' - 60'X15'

b) For given find the parameter in psychrometry table

WBT	DBT	DPT	RH
-----	-----	-----	----



BHARTIYA SKILL DEVELOPMENT UNIVERSITY

50	65	49.98	100%
35	25	10	40
30	86	70	100%

A18) Calculate the required CFM and design the Duct for given building? Height to take 10.'

1) CFM of air required 2) Line diagram for duct design using EFM

DUCT	CFM	VELOCITY	PRESSURE AT	Square size duct(eq.diameter)
Room 1	200		0.08"	
Room 2	500		0.08"	
Room 3	600		0.08"	

Note for Q18: ROOM Dimension 12X12 FT,14X10,12X10

Take NACPH as 4,5,6

DRAW duct run – in answer copies



School of Refrigeration & Air conditioning Skills

Session: 2021-22 (Summer Semester)

B. Voc. Program, V Semester,

End Sem. Examination

Course Code: RAC1302

Time: 1 Hour

Course Name: Central AC System

Max. Marks: 50

1. **Instruction:** Answer all questions from section A, each question carries one mark.
2. Answer all questions from section B, each question carries four mark.
3. Answer all questions from section C, each question carries six mark.
4. Use of Calculator is allowed

Section – A

10 X 01 = 10 Marks

05 objective type questions, each question carries 01 mark.

Q1. _____ fan is used in parking Ventilation?

- a) Ram b) Jet
- c) Board d) coaxial

Q2. Ventilation with Smoke creates a draft known as _____

- a) Back draft b) Fire & smoke
- c) Smog d) Condensate

Q3. Chiller can be classified based on application as _____?

- a) Process & Comfort Chiller b) Power Chiller
- c) Screw Chiller d) Absorption Chiller

Q4. Fire dampers are certified by?

- a) Under writer's laboratory b) Ashrae
- c) Ishrae d) Duct work

Q5. To select a filter _____ is most critical parameter?

- a) Ppm (Parts per Million) b) Pressure drop
- c) Discharge d) All of the above

Q6. Making decisions about when to turn chillers on and off is commonly referred to as chiller?

- a) Sequencing b) Alternative
- c) Throttling d) Lagging

Q7. In a psychrometry _____ is measured?

- a) Water % b) Moisture in Air
- c) Moisture and its impact on temperature d) Relative Humidity 50 %

Q8. An _____ in the condenser approach temperature (that is, the temperature difference between the water and the refrigerant inside the condenser)?

- a) Increase b) Decrease
- c) Remain constant d) Rate of change

Q9. Condenser are designed according to _____?

- a) Dry & wet b) Fin & tube
- c) Tube in tube d) None of the above



BHARTIYA SKILL DEVELOPMENT UNIVERSITY

Q10. In a pressure duct class 2 will be having _____ "W.C?"

- a) 1/2" - 3/4"
- b) 3/4" - 6/8"
- c) 5/4" - 7/4"
- d) None of the above

Section – B

04X04 = 16 Marks

03 short answer type questions, each question carries 04 marks.

- Q11. Draw and label Air washer?
- Q12. Difference between F.CU and A.H.U List any three?
- Q13. Types of evaporator used in chillers with diagram?
- Q14. Common Chiller Problems and Possible Causes?

Section – C

06X04 = 24 Marks

03 Essay type questions, each question carries 06 marks.

Q15. Name the Types of fitting in a duct along with their application? Draw and label

Q16. With a neat diagram explain the Scroll compressor & it's working

Q17. Using the continuity equation calculate the sizes of duct?

Take $Q=AV$ where Q/V as constant

- 1) 36 sq. ft. 2) 169 sq. inches equivalent rectangular sizes?
- 3) 441 sq. ft. 4) 900 sq. in.

b) For given find the parameter in psychrometry table

WBT	DBT	DPT	RH
50	65		
35		10	
30			100%

Q18) Calculate the required CFM and design the Duct for given building? Height to take 10.'

- 1) CFM of air required 2) Line diagram for duct design using EFM

DUCT	CFM	VELOCITY	PRESSURE AT	Square size duct(eq.diameter)
Room 1	200		0.08"	
Room 2	500		0.08"	
Room 3	600		0.08"	

Note for Q18: ROOM Dimension 12X12 FT, 14X10, 12X10

Take NACPH as 4,5,6

DRAW duct run – in answer copies

PSYCHROMETRIC CHART
BAROMETRIC PRESSURE 29.921 inches of Mercury

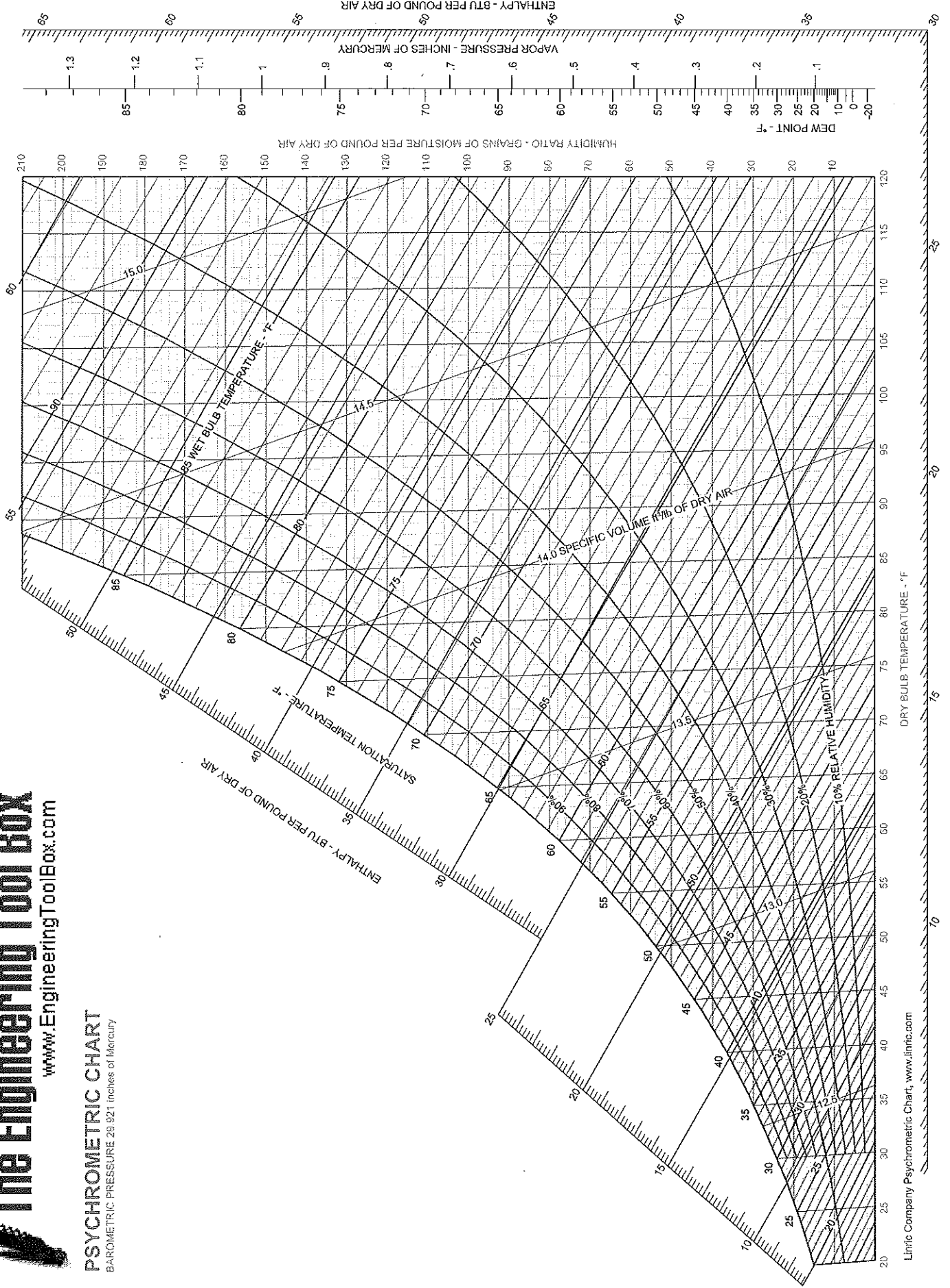

Handwritten signatures and initials.



BHARTIYA SKILL DEVELOPMENT UNIVERSITY

04x04 = 16 Marks

11. What Is Electromagnetic Induction?
12. Explain The Power Factor?
13. What are types Of AC motors.
14. Explain The Difference Between Ac And Dc

Section – C

04x06 = 24 Marks

15. Explain The Classification Of Three Phase Induction Motors?.
16. Explain The Split Phase Starting Method Of Single Phase Induction Motors?
17. Explain The Applications And Disadvantages Of Single Phase Induction Motors?
18. Explain The Applications And Working Of Slip Ring Motor?

B



BHARTIYA SKILL DEVELOPMENT UNIVERSITY

Registration No.:

School Of Refrigeration & Air Conditioning Skills

Session: 2021-22 (Summer Semester)

B. Voc. Program, III Semester,

End-Sem. Examination

Course Code: RAC1303

Course Name: RAC Electrical, Electronics And Instrumentation - II

Instruction:

Time: 2 Hours

Max. Marks: 50

Set - A Section - A

10x01 = 10 Marks

1. In Resistor Split Phase Motors Main Winding M Has A
 - a. High Resistance
 - b. Low Resistance
 - c. None Of The Above
 - d. All Of The Above
2. The Two Windings Of Split Phase Single Phase Motors Are Connected In
 - A. Series
 - B. Parallel
 - C. Axial
 - D. Radial
3. What Is CSR?
 - A. Capacitor Start Capacitor Run
 - B. Capacitor Start Induction Run
 - C. Control Start Induction Run
 - D. None Of The Above
4. Fleming's Right Hand Rule Is For
 - A. Motor
 - B. Generators
 - C. Transformers
 - D. Transistors
5. In Resistor Split Phase Motors Starting Winding Has A :
 - A. High Resistance
 - B. Low Resistance
 - C. None Of The Above
 - D. All Of The Above
6. The Main Parts Of an Induction Motor Are
 - A) Stator
 - B) Rotor
 - C) Both
 - D) None
7. Rsr Motor Is
 - A) Resistor Start Induction Run
 - B) Resistor Start Impedance Run
 - C) Reactance Start Induction Run
 - D) Resistor Start Inductance Run
8. Split Phase Induction Motors Have Two Winding Naming
 - A) Starting And Running Winding
 - B) Main And Auxiliary Winding
 - C) Current And Relay Winding
 - D) Both A And B
9. What Is CSIR?
 - A. Capacitor Start Capacitor Run
 - B. Capacitor Start Induction Run
 - C. Control Start Induction Run
 - D. None Of The Above
10. Fleming's Left Hand Rule Is For
 - A. Motor
 - B. Generators
 - C. Transformers
 - D. Transistors

Section - B



11. What Is Electromagnetic Induction?

Answer: Electromagnetic Induction is a current produced because of voltage production (electromotive force) due to a changing magnetic field.

This either happens when a conductor is placed in a moving magnetic field (when using AC power source) or when a conductor is constantly moving in a stationary magnetic field.

12. Explain The Power Factor?

Answer: Power factor is an expression of energy efficiency. It is usually expressed as a percentage—and the lower the percentage, the less efficient power usage is.

Power factor (PF) is the ratio of working power, measured in kilowatts (kW), to apparent power, measured in kilovolt amperes (kVA). Apparent power, also known as demand, is the measure of the amount of power used to run machinery and equipment during a certain period. It is found by multiplying (kVA = V x A). The result is expressed as kVA units.

13. Types of AC motors.

Answer: AC Motors classification based on Principle of Operation:

- Synchronous Motors
- Plain
- Super
- Asynchronous Motors
- Induction Motors
- Squirrel Cage
- Slip-Ring
- Commutator Motors
- Series
- Compensated
- Shunt
- Repulsion
- Repulsion induction
- Repulsion-start induction

14. Explain The Difference Between Ac And Dc

Alternating Current	Direct Current
AC is safe to transfer longer distance even between two cities, and maintain the electric power.	DC cannot travel for a very long distance. It loses electric power.
The rotating magnets cause the change in direction of electric flow.	The steady magnetism makes DC flow in a single direction.
The frequency of AC is dependent upon the country. But, generally, the frequency is 50 Hz or 60 Hz.	DC has no frequency of zero frequency.
In AC the flow of current changes its direction backwards periodically.	It flows in a single direction steadily.
Electrons in AC keep changing its directions – backward and forward	Electrons only move in one direction – that is forward.

Section – C

04x06 = 24 Marks

15. Explain The Classification Of Three Phase Induction Motors?.

Answer: Squirrel Cage Induction Motor:

The Rotor consists of a cylindrical laminated core. The construction of this rotor is simple and rugged.

Rotor conductors are thick copper bars and placed in the slots. The rotor conductors are permanently short-circuited with the help of end rings. Thus, it is not possible to add external resistance in the rotor circuit.

Rotor body made up from silicon steel stampings. The construction of rotor looks like a cage of a squirrel. So, this motor is known as the squirrel cage induction motor.

2) Wound Rotor Induction Motor:

The rotor is made up of lamination with the slots on the outer periphery. Three-phase rotor winding placed in the slots in such a way that the number of stator poles are same as the number of rotor poles. Generally, rotor winding is star connected internally. So, three terminals can bring out from the rotor on which we can add external resistance. These terminals connect with the slip-rings mounted on the shaft.

16. Explain The Split Phase Starting Method Of Single Phase Induction Motors?

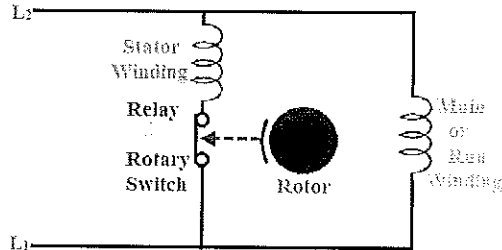

Answer: This method is majorly employed in simple industrial duty motors. These motors consist of two sets of windings, namely, start winding and main or run winding. The start winding is made from smaller wire with which it offers high resistance to electrical flow compared to run winding. Due to this high resistance, magnetic field is developed in start winding by the current earlier than run winding magnetic field development. Thus, two fields are 30 degrees apart, but this small angle itself is enough to start the motor.

17. Explain The Applications And Disadvantages Of Single Phase Induction Motors?

Answer: Advantages of Induction Motor



The most important advantage of an induction motor is that its construction is quite simple in nature. The construction of the Stator is similar in both Synchronous motors as well as induction motors. However, a slip ring is required to feed DC Supply to the Rotor in the case of a Synchronous Generator. These Slip rings are not required in a Squirrel cage induction motor because the windings are permanently short circuited. When compared with a DC Motor, the induction motor does not have Brushes and hence, maintenance required is quite low. This leads to a simple construction. The working of the motor is independent of the environmental condition. This is because the induction motor is Robust and mechanically strong.

A Squirrel cage induction motor does not contain Brushes, Slip rings and Commutators. Due to this reason, the cost of the motor is quite low. However, Slip Rings are used in Wound type induction motor to add external resistance to the rotor winding.

18. Explain The Applications And Working Of Slip Ring Motor?

Answer: This motor runs on the principle of Faraday's law of electromagnetic induction. When a stator winding is excited with an AC supply, the stator winding produces magnetic flux. Based on Faraday's law of electromagnetic induction, the rotor winding gets induced and generates a current of magnetic flux. This induced EMF develops torque that enables the rotor to rotate.

However, the phase difference between the voltage and current do not meet the requirements to generate high starting torque as torque developed is not unidirectional. The external resistance of high value is connected with the circuit to improve the phase difference of a motor. As a result, inductive reactance and phase difference between I and V is reduced. Consequently, this reduction helps the motor to generate high starting torque.



BHARTIYA SKILL DEVELOPMENT UNIVERSITY

Registration No.:

School of Refrigeration & Air Conditioning Skills

Session: 2021-22 (Summer Semester)

B. Voc. Program, III Semester,

End-Sem. Examination

Course Code: RAC1303

Course Name: RAC Electrical, Electronics and Instrumentation - II

Instruction: In section A write both answer and option.

Time: 2 Hours

Max. Marks: 50

Set - B

Section - A

10X01 = 10 Marks

1. The power rating of CSIR motor lies between:
 - a. 120 - 750 W
 - b. 130 - 800 W
 - c. 140 - 750 W
 - d. 150 - 500 W
2. The power rating of the CSR motor lies between?
 - a. 110 - 750 W
 - b. 110 - 750 W
 - c. 110 - 750 W
 - d. 110 - 750 W
3. Capacitor run motor is also known as?
 - a. Permanent start capacitor motor
 - b. Permanent Shock capacitor motor
 - c. Permanent Split capacitor motor
 - d. None of the above
4. The power rating of the shaded pole motor lies between?
 - a. 20 - 40 W
 - b. 30 - 50 W
 - c. 30 - 50 W
 - d. 30 - 50 W
5. The two main parts of a three phase induction motor are?
 - a. Stator
 - b. Rotor
 - c. Windings
 - d. Both a and b
6. Wound rotor three phase induction motor is also known as :
 - a. Split phase
 - b. Slip ring
 - c. None of the above
 - d. All of the above
7. Asynchronous motor commonly known as?
 - a. Split phase motor
 - b. Synchronous motor
 - c. Induction motors
 - d. three phase motor
8. Other types of motors are
 - a. BLDC motors
 - b. Stepper motors
 - c. Universal Motors
 - d. All of the above
9. The two types of electrical connections in the three phase motors are?



BHARTIYA SKILL DEVELOPMENT UNIVERSITY

- a. Star connections
 - b. Delta connections.
 - c. Phase connections
 - d. Both a and b
10. Fleming's right hand rule is for?
- a. Motor
 - b. Generators
 - c. Transformers
 - d. transistors

Section – B

04X04 = 16 Marks

- 11. What is a synchronous motor?
- 12. Write the types of motor other than AC and DC.
- 13. Explain the two types of electrical connections of three phase motors?
- 14. Why does a single phase fail to develop the starting torque?

Section – C

04X06 = 24 Marks

- 15. Explain the construction of three phase induction motors?
- 16. Explain the self excited DC motor and its types?
- 17. Explain the applications and advantages of three phase induction motors?
- 18. Explain the applications and working of squirrel cage motor?



BHARTIYA SKILL DEVELOPMENT UNIVERSITY

Registration No.:

School of Refrigeration & Air Conditioning Skills
Session: 2021-22 (Summer Semester)
B. Voc. Program, III Semester,
End-Sem. Examination

Course Code: RAC1303

Course Name: RAC Electrical, Electronics and Instrumentation - II

Instruction: In section A write both answer and option.

Time: 2 Hours

Max. Marks: 50

Set - B

Section - A
Answer Sheet

10X01 = 10 Marks

1. The power rating of CSIR motor lies between:
 - a. 120 - 750 W
 - b. 130 - 800 W
 - c. 140 - 750 W
 - d. 150 - 500 W
2. The power rating of the CSR motor lies between?
 - a. 170 - 750 W
 - b. 110 - 790 W
 - c. 110 - 750 W
 - d. 510 - 710 W
3. Capacitor run motor is also known as?
 - a. Permanent start capacitor motor
 - b. Permanent Shock capacitor motor
 - c. Permanent Split capacitor motor
 - d. None of the above
4. The power rating of the shaded pole motor lies between?
 - a. 20 - 40 W
 - b. 30 - 50 W
 - c. 30 - 50 W
 - d. 30 - 50 W
5. The two main parts of a three phase induction motor are?
 - a. Stator
 - b. Rotor
 - c. Windings
 - d. Both a and b
6. Wound rotor three phase induction motor is also known as :
 - a. Split phase
 - b. Slip ring
 - c. None of the above
 - d. All of the above
7. Asynchronous motor commonly known as?
 - a. Split phase motor
 - b. Synchronous motor
 - c. Induction motors
 - d. three phase motor
8. Other types of motors are
 - a. BLDC motors
 - b. Stepper motors
 - c. Universal Motors
 - d. All of the above



BHARTIYA SKILL DEVELOPMENT UNIVERSITY

9. The two types of electrical connections in the three phase motors are?
- Star connections
 - Delta connections
 - Phase connections
 - Both a and b
10. Fleming's right hand rule is for?
- Motor
 - Generators
 - Transformers
 - transistors

Section – B

04X04 = 16 Marks

11. What is a synchronous motor?

Answer: A synchronous motor is one in which the rotor normally rotates at the same speed as the revolving field in the machine. The stator is similar to that of an induction machine consisting of a cylindrical iron frame with windings, usually three-phase, located in slots around the inner periphery

12. Write the types of motor other than AC and DC.

Answer:

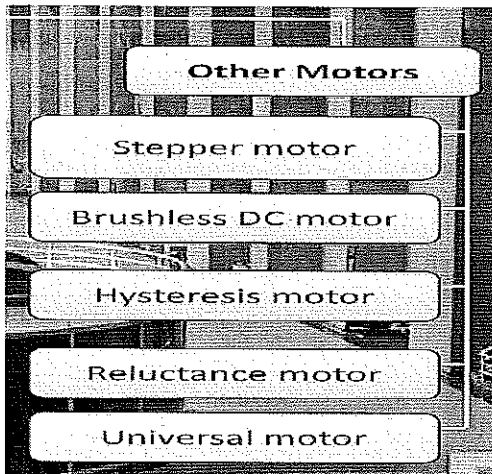

13. Explain the two types of electrical connections of three phase motors?

Answer: A star delta starter is the most commonly used method for the starting of a 3 phase induction motor. In star delta starting an induction motor is connected through a star connection throughout the starting period. Then once the motor reaches the required speed, the motor is connected through a delta connection.

14. Why does a single phase fail to develop the starting torque?

Answer: By electromagnetic induction, e.m.f's are induced in the rotor conductors. Since the rotor forms a closed circuit, currents are induced in the rotor bars. Due to the interaction between the rotor-induced currents and the stator flux, a torque is produced. ... Thus the single-phase motor fails to develop starting torque.

Section – C

04X06 = 24 Marks

15. Explain the construction of three phase induction motors?

Answer: Stator: As its name indicates stator is a stationary part of an induction motor. A stator winding is placed in the stator of the induction motor and the three phase supply is given to it.

Rotor: The rotor is a rotating part of an induction motor. The rotor is connected to the mechanical load through the shaft.



BHARTIYA SKILL DEVELOPMENT UNIVERSITY

16. Explain the self excited DC motor and its types?

Answer:

Shunt Wound DC Motors

In Shunt Wound DC Motors, the field windings are connected in parallel to the armature winding and are exposed to the entire terminal voltage in a DC motor.

Series Wound DC motor

In the series wound DC motor, the field winding is connected in series to the armature winding and the entire armature current passes through it.

The field winding is connected in series with the armature winding in a series wound DC motor. A series DC motor has a strong starting torque and is frequently used to start high-inertia loads like trains, elevators, and hoists.

Compound wound DC motor

As the name suggested, the compound wound DC motor is the compound or the mixture of shunt and the series field winding. This type of DC motor is used when high-speed torque and good speed regulation both are needed.

17. Explain the applications and advantages of three phase induction motors?

Answer:

- The construction of a motor is very simple and robust.
- The working of an induction motor is very simple.
- It can operate in any environmental condition.
- The efficiency of the motor is very high.
- The maintenance of an induction motor is less compared to other motors.
- It is a single excited motor. Hence, it needs only one supply of source. It does not require external DC supply for excitation like a synchronous motor.
- The induction motor is a self-starting motor. So, it does not require any extra auxiliaries for the starting purpose for normal operation.

18. Explain the applications and working of squirrel cage motor?

Answer: Applications:

- Centrifugal pumps
- Industrial drives (e.g. to run conveyor belts)
- Large blowers and fans
- Machine tools
- Lathes and other turning equipment

Some advantages of squirrel cage induction motors are:

- They are low cost
- Require less maintenance (as there are no slip rings or brushes)
- Good speed regulation (they are able to maintain a constant speed)
- High efficiency in converting electrical energy to mechanical energy (while running, not during startup)
- Have better heat regulation (i.e. don't get as hot)
- Small and lightweight
- Explosion proof (as there are no brushes which eliminate the risks of sparking)

Deigh





BHARTIYA SKILL DEVELOPMENT UNIVERSITY

School of Refrigeration & Air Conditioning Skills

Session: 2021-22 (Summer Semester)

B. Voc. Program, V Semester,

End-Sem. Examination

Course Code: SAC1304

Time: 2 Hours

Course Name: Cold Chain & Cold Storage

Max. Marks: 50

SET-A

Instruction:

All questions are compulsory.

Section A is objective type.

Section B is short answer type.

Section C is long answer type.

Scientific calculator is allowed.

Section – A

10X01 = 10 Marks

1. How food products get affected by a damage?
 - a. Decrease in shelf life
 - b. Increase in shelf life
 - c. No effect
 - d. None of the above
2. Pre cooling of foods done for-.
 - a. Reducing cooling load in cold room
 - b. Increasing cooling load in cold room
 - c. Not Comparable
 - d. None of the above
3. How rate of respiration affects the storage life of horticulture products?
 - a. The higher the rate, the shorter the life
 - b. The lower the rate, the longer the life.
 - c. a & b both
 - d. None of the above
4. FIFO stands for-.
 - a. First in first out
 - b. Floor in floor out
 - c. Final in final out
 - d. None of the above
5. 2500 W is equal to-.
 - a. 25 Kw
 - b. 2.5 Kw
 - c. 0.25 Kw
 - d. 250 Kw
6. 5400 KJ is equal to-.
 - a. 1.5 KWh
 - b. 15 KWh
 - c. 0.15 KWh
 - d. None of the above



**BHARTIYA SKILL DEVELOPMENT UNIVERSITY**

7. What is the measuring unit of density?
- Kg/m^3
 - m^3/Kg
 - W/m^2
 - None of the above
8. Which of the following is correct for heat rejection ratio (HRR)?
- $0.5 \leq \text{HRR} \leq 1$
 - $0 \leq \text{HRR} \leq 1$
 - $0 \leq \text{HRR} < 1$
 - $0 \leq \text{HRR} \geq 1$
9. Specific heat of water is higher than the specific heat of air.
- True
 - False
 - Not comparable
 - None of the above
10. Which of the following is known as constant pressure type expansion device?
- Capillary tube
 - Thermostatic expansion valve
 - Automatic expansion valve
 - All of the mentioned

Section – B

04X04 = 16 Marks

- Write down the reason for using multistage compression.
- Write down the importance of heat rejection ratio.
- Write a short note on Deep freezer.
- Write down the factors need to be considered for successful produce storage.

Section – C

04X06 = 24 Marks

- Explain the physiology of fruits and vegetables in detail.
- Explain the working of cooling tower with the help of diagram in detail.
- Following data given for a cold room:

Store Dimensions: 15mX10mX5m. Over all U Value - 0.35 w/sqm°C. Outside Design Conditions: 35°C DBT, 20°C WBT (Enthalpy = 66 KJ/Kg), Inside Design Conditions: 4°C+/-1°C, 75%RH (Enthalpy = 13 KJ/Kg). Product: Daily 2500Kg/24 hrs coming at 35°C with specific heat 3.0 KJ/Kg°C and 2APCH. Consider 4 men working for 4 hours daily. 4 fans are used of motor capacity 150 W each and run for 10 hours. 4 Lamps are used of capacity 50 W each and run for 5 hours. Each cubic meter of new air provides 2KJ/cm°C. Find out total load.

- Store Dimensions: 10mX6mX3m. Over all U Value - 0.24 w/sqm°C. Outside Design Conditions: 40°C DBT, 25°C WBT (Enthalpy = 94 KJ/Kg), Inside Design Conditions: 4°C+/-1°C, 75%RH (Enthalpy = 13 KJ/Kg). Product: Daily 3000Kg/24 hrs coming at 30°C. Consider 2 men working for 4 hours daily. 4 fans are used of motor capacity 120 W each and run for 10 hours. 4 Lamps are used of capacity 100 W each and run for 5 hours. Consider specific heat of product is 2.5 KJ/Kg°C and 2 ACPH. Find out total load.

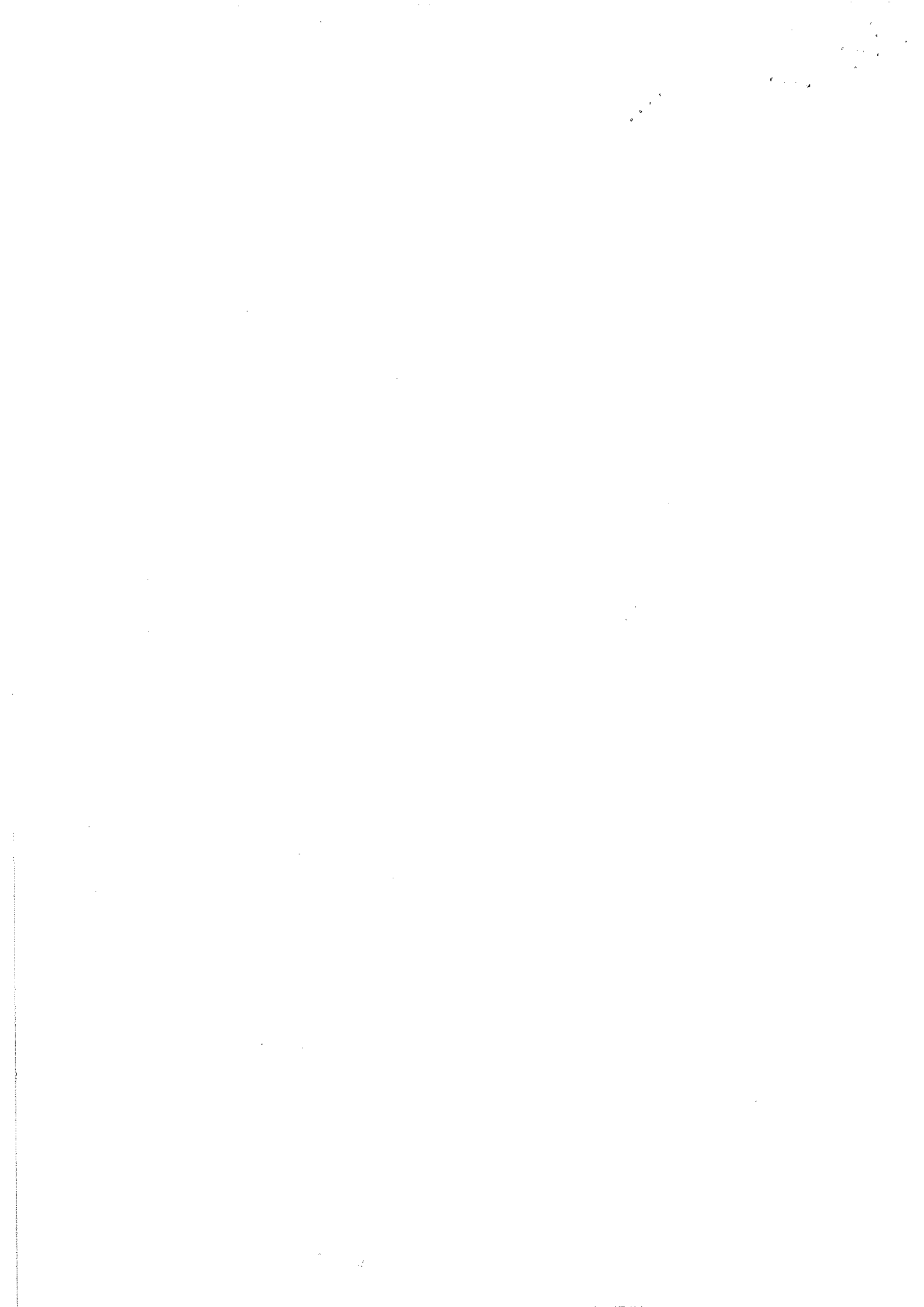

**BHARTIYA SKILL DEVELOPMENT UNIVERSITY****School of Refrigeration & Air Conditioning Skills****Session: 2021-22 (Summer Semester)****B. Voc. Program, V Semester,****End-Sem. Examination**

Course Code: HVA1304

Time: **2 Hours**

Course Name: Cold Chain & Cold Storage

Max. Marks: 50

ANSWER KEY-A**Section – A**

10X01 = 10 Marks

1. How food products get affected by a damage?
 - a. **Decrease in shelf life**
 - b. Increase in shelf life
 - c. No effect
 - d. None of the above
2. Pre cooling of foods done for-.
 - a. **Reducing cooling load in cold room**
 - b. Increasing cooling load in cold room
 - c. Not Comparable
 - d. None of the above
3. How rate of respiration affects the storage life of horticulture products?
 - a. The higher the rate, the shorter the life
 - b. The lower the rate, the longer the life.
 - c. **a & b both**
 - d. None of the above
4. FIFO stands for-.
 - a. **First in first out**
 - b. Floor in floor out
 - c. Final in final out
 - d. None of the above
5. 2500 W is equal to-.
 - a. 25 Kw
 - b. **2.5 Kw**
 - c. 0.25 Kw
 - d. 250 Kw
6. 5400 KJ is equal to-.
 - a. **1.5 KWh**
 - b. 15 KWh
 - c. 0.15 KWh
 - d. None of the above
7. What is the measuring unit of density?
 - a. **Kg/m³**
 - b. m³/Kg
 - c. W/m²
 - d. None of the above
8. Which of the following is correct for heat rejection ratio (HRR)?
 - a. $0.5 \leq HRR \leq 1$
 - b. **$0 \leq HRR \leq 1$**
 - c. $0 \leq HRR < 1$
 - d. $0 \leq HRR \geq 1$

BHARTIYA SKILL DEVELOPMENT UNIVERSITY

9. Specific heat of water is higher than the specific heat of air.
- True
 - False
 - Not comparable
 - None of the above
10. Which of the following is known as constant pressure type expansion device?
- Capillary tube
 - Thermostatic expansion valve
 - Automatic expansion valve
 - All of the mentioned

Section – B

04X04 = 16 Marks

1. Write down the reason for using multistage compression.

When the compression ratio required is considerably high, as in the case of low temperature refrigeration systems, the single-stage compression is highly uneconomical due to the following reasons.

- Very low volumetric efficiency
- High frictional losses
- Leakage problems
- High running cost

In multistage compression, the compression of refrigerant from initial pressure to final pressure is carried out in more than one cylinder. A multistage compression with intermediate cooling is generally adopted for economical working.

2. Write down the importance of heat rejection ratio.

The loading on the condenser per unit of refrigeration is called heat rejection ratio.

Because $Q_k = Q_0 + w$, the heat rejection ratio is

$$\frac{Q_k}{Q_0} = 1 + \frac{W}{Q_0} =$$

$$\text{Heat rejection ratio} = \frac{\text{Heat rejected in the condenser}}{\text{Heat absorbed in the evaporator}}$$

Where

Q_k / Q_0 = heat rejection ratio

Q_k = heat removed in the condenser

Q_0 = heat load from the evaporator

W = heat equivalent of work from the compressor

BHARTIYA SKILL DEVELOPMENT UNIVERSITY

3. Write a short note on Deep freezer.

CCE- Deep Freezer

- *Deep Freezer is an equipment, which operates on a vapour compression system similar to any conventional type of refrigerator operating on 220 volts, A.C. mains supply.*
- *DF has top opening lid to prevent loss of cold air during door opening.*
- *Cabinet temperature is maintained between -15°C to -25° C.*
- *Used for storing of OPV at district level.*
- Available in different sizes:
 - 264 liters or 380 icepacks
 - 72 liters or 130 icepacks
 - 80 liters or 140 ice packs.

4. Write down the factors need to be considered for successful produce storage.

- **Temperature**
- **Relative humidity**
- **Atmospheric composition:**

The atmospheric composition in a storage room is controlled by addition of gases allowing the commodity to produce or consume gases or by physically or chemically removing undesirable gases from the storage room.

- **Air movement:**

Air movement must be sufficient to remove respiration heat. Because it is essential that all parts of the room are subject to a uniform flow of air, proper placement of blowers or ducts and stacking of fruits and vegetables will permit free air flow.

Light and other factors

Section – C

04X06 = 24 Marks

1. Explain the physiology of fruits and vegetables in detail.

BHARTIYA SKILL DEVELOPMENT UNIVERSITY

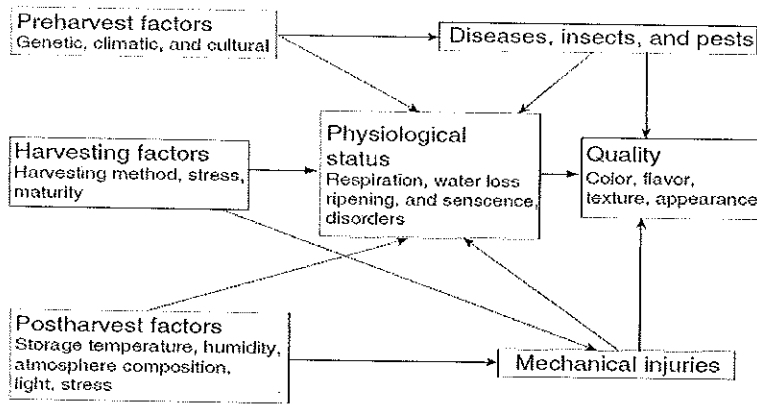

2. Explain the working of cooling tower with the help of diagram in detail.

Cooling towers are divided into three main groups: natural draft cooling towers, forced draft cooling towers and induced draft cooling towers.

Natural Draft Atmospheric Spray Towers

- ✓ This tower should be located in open space or on the roof of the building where the movement of air is best.
- ✓ The capacity of this cooling tower is nearly 30–75 L per square meter of base area, depending upon the air velocity.
- ✓ They work economically for loads under 200 tons capacity.
- ✓ **In forced draft cooling towers** water from the condenser is sprayed at the top of the tower and air is forced by the blower from the bottom of the tower. The air velocity of 120 m/min is recommended with a flow of 100–130 cmm per min per ton of refrigeration capacity.
- ✓ The amount of water usually lost with forced or induced draft cooling tower ranges from 1% to 2% by evaporation and 0.5% to 2% by drift losses. The water for compensating these losses is supplied from external sources. The water must be chemically treated to avoid scale formation of the condenser due to an increase in the concentration of salt in the cooling water.

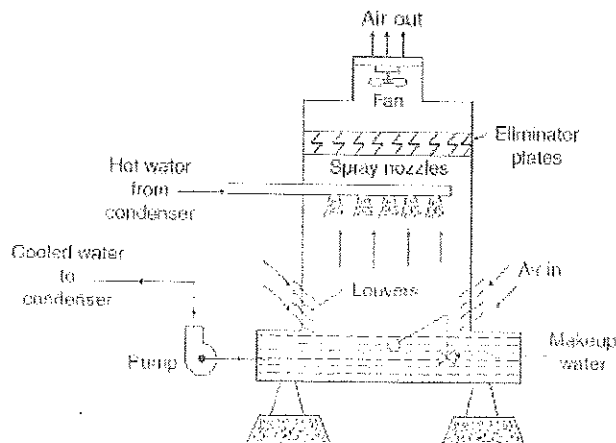

3. Following data given for a cold room:



BHARTIYA SKILL DEVELOPMENT UNIVERSITY

Store Dimensions: 15mX10mX5m. Over all U Value - 0.35 w/sqm°C. Outside Design Conditions: 35°C DBT, 20°C WBT (Enthalpy = 66 KJ/Kg), Inside Design Conditions: 4°C+/-1°C, 75%RH (Enthalpy = 13 KJ/Kg). Product: Daily 2500Kg/24 hrs coming at 35°C with specific heat 3.0 KJ/Kg°C and 2APCH. Consider 4 men working for 4 hours daily. 4 fans are used of motor capacity 150 W each and run for 10 hours. 4 Lamps are used of capacity 50 W each and run for 5 hours. Each cubic meter of new air provides 2KJ/cm°C. Find out total load.

1. Transmission Load

$$Q = U \cdot A \cdot (\text{Outside Temperature} - \text{Inside Temperature}) \cdot 24/1000$$

$$= 138.6 \text{ Kwh/day}$$

2. Product Load

$$Q = M \cdot C_p \cdot (\text{Outside Temperature} - \text{Inside Temperature}) / (3600)$$

$$= 62.5 \text{ Kwh/day}$$

3. Occupancy Load

$$Q = \text{persons} \cdot \text{Time} \cdot \text{Heat} / 1000$$

$$= 4 \text{ Kwh/day}$$

4. Lighting Load

$$Q = \text{Lamps} \cdot \text{Time} \cdot \text{Wattage} / 1000$$

$$= 1 \text{ Kwh/day}$$

5. Equipment Load

$$Q = \text{Fans} \cdot \text{Time} \cdot \text{Wattage} / 1000$$

$$= 6 \text{ Kwh/day}$$

6. Infiltration Load

$$Q = \text{Changes} \cdot \text{Energy} \cdot \text{Volume} \cdot (\text{Outside Temperature} - \text{Inside Temperature}) / 3600$$

$$= 44.1 \text{ Kwh/day}$$

Therefore,

Total Load = Sum of all loads:

$$256 \text{ Kwh/day ans.}$$

4. Store Dimensions: 10mX6mX3m. Over all U Value - 0.24 w/sqm°C. Outside Design Conditions: 40°C DBT, 25°C WBT (Enthalpy = 94 KJ/Kg), Inside Design Conditions: 4°C+/-1°C, 75%RH (Enthalpy = 13 KJ/Kg). Product: Daily 3000Kg/24 hrs coming at 30°C. Consider 2 men working for 4 hours daily. 4 fans are used of motor capacity 120 W each and run for 10 hours. 4 Lamps are used of capacity 100 W each and run for 5 hours. Consider specific heat of product is 2.5 KJ/Kg°C and 2 ACPH. Find out total load.

**BHARTIYA SKILL DEVELOPMENT UNIVERSITY**

1. Transmission Load

$$Q = U \cdot A \cdot (\text{Outside Temperature} - \text{Inside Temperature}) \cdot 24/1000$$

$$= 44.7 \text{ Kwh/day}$$

2. Product Load

$$Q = M \cdot C_p \cdot (\text{Outside Temperature} - \text{Inside Temperature}) / (3600)$$

$$= 54.1 \text{ Kwh/day}$$

3. Occupancy Load

$$Q = \text{persons} \cdot \text{Time} \cdot \text{Heat} / 1000$$

$$= 2.2 \text{ Kwh/day}$$

4. Lighting Load

$$Q = \text{Lamps} \cdot \text{Time} \cdot \text{Wattage} / 1000$$

$$= 2 \text{ Kwh/day}$$

5. Equipment Load

$$Q = \text{Fans} \cdot \text{Time} \cdot \text{Wattage} / 1000$$

$$= 4.8 \text{ Kwh/day}$$

6. Infiltration Load

$$Q = \text{Changes} \cdot \text{Energy} \cdot \text{Volume} \cdot (\text{Outside Temperature} - \text{Inside Temperature}) / 3600$$

$$= 10.5 \text{ Kwh/day}$$

Therefore,

Total Load = Sum of all loads:

118.3 Kwh/day ans.



Registration No.:

BHARTIYA SKILL DEVELOPMENT UNIVERSITY

School of Refrigeration & Air Conditioning Skills

Session: 2021-22 (Summer Semester)

B. Voc. Program, V Semester,

End-Sem. Examination

Course Code: RAC1304

Time: 2 Hours

Course Name: Cold Chain & Cold Storage

Max. Marks: 50

SET-B

Instruction:

- All questions are compulsory.
- Section A is objective type.
- Section B is short answer type.
- Section C is long answer type.
- Scientific calculator is allowed.

Section – A

10X01 = 10 Marks

1. Damage of food product may start in-.
 - a. Harvesting
 - b. Distribution
 - c. Processing
 - d. All of the above
2. Food preservation is done for-.
 - a. Maintaining nutritious
 - b. Maintaining flavor
 - c. Maintaining texture
 - d. All of the above
3. In DX chiller refrigerant flows through-.
 - a. Tubes
 - b. Shell
 - c. a & b both
 - d. None of the above
4. Power consumption in induced draft cooling tower fan is higher than forced draft cooling tower fan-.
 - a. True
 - b. False
 - c. Equal
 - d. Not comparable
5. What is food preservation?
 - a. Retaining food over a period of time
 - b. Distribution food over a period of time
 - c. Harvesting food over a period of time
 - d. None of the above
6. causes of food deterioration and spoilage are-.
 - a. Mechanical effects
 - b. Physical effects
 - c. Microbial effects
 - d. All of the above

**BHARTIYA SKILL DEVELOPMENT UNIVERSITY**

7. Which of the following is food preservation method?
- Inhibition
 - Inactivation
 - Avoid recontamination
 - All of the above
8. Specific heat of water is higher than the specific heat of air.
- True
 - False
 - Not comparable
 - None of the above
9. Which of the following is correct for heat rejection ratio (HRR)?
- $0.5 \leq \text{HRR} \leq 1$
 - $0 \leq \text{HRR} \leq 1$
 - $0 \leq \text{HRR} < 1$
 - $0 \leq \text{HRR} \geq 1$
10. 2500 W is equal to-
- 25 Kw
 - 2.5 Kw
 - 0.25 Kw
 - 250 Kw

Section – B

04X04 = 16 Marks

- Write down the definition of food and food preservation.
- Write down the different food preservation methods through flow diagram.
- What are the climacteric and non- climacteric type fruit?
- Write a short note on walk in freezer.

Section – C

04X06 = 24 Marks

- Explain all the terms required for load estimation for cold storages in detail.
- Explain the post-harvest value chain for fruits and vegetables with the help of diagram in detail.
- Following data given for a cold room:
Store Dimensions: 15mX10mX5m. Over all U Value - 0.35 w/sqm°C. Outside Design Conditions: 35°C DBT, 20°C WBT (Enthalpy = 66 KJ/Kg), Inside Design Conditions: 4°C+/-1 °C, 75%RH (Enthalpy = 13 KJ/Kg). Product: Daily 2500Kg/24 hrs coming at 35°C with specific heat 3.0 KJ/Kg°C and 2APCH. Consider 4 men working for 4 hours daily. 4 fans are used of motor capacity 150 W each and run for 10 hours. 4 Lamps are used of capacity 50 W each and run for 5 hours. Each cubic meter of new air provides 2KJ/cm°C. Find out total load.
- A cold storage of dimension 10mx5mx3m. Outside and inside temperatures are 30°C and 6°C, while the floor temperature is 8°C. Overall heat transfer coefficient is 0.37 w/sqm°C. 2500 Kgs of apple are to be stored and 4 people work daily for four hours inside the cold storage and each person generates heat of 270 W. Specific heat of apple is 2.2 kJ kg⁻¹ °C⁻¹. Enthalpy at 30°C DBT and 18.5°C WBT is 63 KJ/Kg of da. Enthalpy at 6°C and 90% RH is 20 KJ/Kg of da. 4 fans are used of motor capacity 120 W each and run for 10 hours. 4 Lamps are used of capacity 100 W each and run for 5 hours. Find out total load of storage (Consider 2 ACPH and respiration rate of product is 9.1 KJ/Kg/day).



BHARTIYA SKILL DEVELOPMENT UNIVERSITY

School of Refrigeration & Air Conditioning Skills

Session: 2021-22 (Summer Semester)

B. Voc. Program, V Semester,

End-Sem. Examination

Course Code: HVA1304

Time: **2 Hours**

Course Name: Cold Chain & Cold Storage

Max. Marks: 50

ANSWER KEY-B

Section – A

10X01 = 10 Marks

1. Damage of food product may start in-
 - a. Harvesting
 - b. Distribution
 - c. Processing
 - d. **All of the above**

2. Food preservation is done for-
 - a. Maintaining nutritious
 - b. Maintaining flavor
 - c. Maintaining texture
 - d. **All of the above**

3. In DX chiller refrigerant flows through-
 - a. Tubes
 - b. **Shell**
 - c. a & b both
 - d. None of the above

4. Power consumption in induced draft cooling tower fan is higher than forced draft cooling tower fan-
 - a. True
 - b. **False**
 - c. Equal
 - d. Not comparable

5. What is food preservation?
 - a. **Retaining food over a period of time**
 - b. Distribution food over a period of time
 - c. Harvesting food over a period of time
 - d. None of the above

6. causes of food deterioration and spoilage are-
 - a. Mechanical effects
 - b. Physical effects
 - c. Microbial effects
 - d. **All of the above**

7. Which of the following is food preservation method?
 - a. Inhibition
 - b. Inactivation
 - c. Avoid recontamination
 - d. **All of the above**

8. Specific heat of water is higher than the specific heat of air.
 - a. **True**
 - b. False
 - c. Not comparable
 - d. None of the above

BHARTIYA SKILL DEVELOPMENT UNIVERSITY

9. Which of the following is correct for heat rejection ratio (HRR)?
- $0.5 \leq HRR \leq 1$
 - $0 \leq HRR \leq 1$
 - $0 \leq HRR < 1$
 - $0 \leq HRR \geq 1$
10. 2500 W is equal to-
- 25 Kw
 - 2.5 Kw
 - 0.25 Kw
 - 250 Kw

Section – B

04X04 = 16 Marks

1. Write down the definition of food and food preservation.

What Are Foods?

Foods are materials, raw, processed, or formulated, that are consumed orally by humans or animals for growth, health, satisfaction, pleasure, and satisfying social needs.

What is food preservation?

Retaining food over a period of time without being contaminated by pathogenic organisms or chemicals and without losing its colour, texture, flavour and nutritious value.

2. Write down the different food preservation methods through flow diagram.

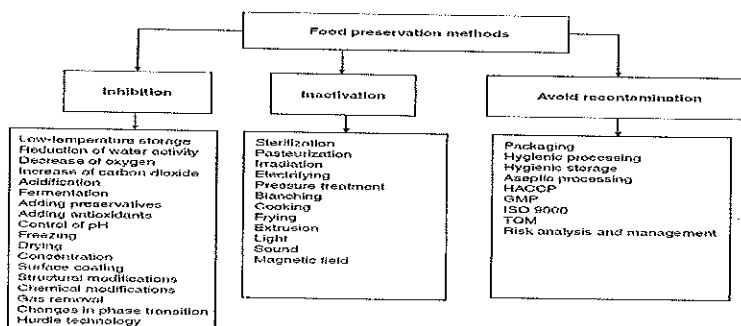

3. What are the climacteric and non- climacteric type fruit?

Climacteric fruits

Those in which ripening is associated with a distinct increase in respiration and ethylene production, the respiration rate rising up to the climacteric peak and then declining. Such an increase can occur either while the fruit is attached to or separated from the plant. A further distinguishing feature is that treatment of climacteric fruits with ethylene or propylene stimulates both respiration and autocatalytic ethylene production. Low temperatures greatly reduce the magnitude of the climacteric. The climacteric generally coincides with changes associated with ripening such as colour changes, softening, increased tissue permeability, and the development of characteristic aromas. Typical climacteric fruits include apples, pears, peaches, nectarines, bananas, mangoes, plums, tomatoes, and avocados.

BHARTIYA SKILL DEVELOPMENT UNIVERSITY

Non-Climacteric fruits

In non climacteric fruits, ripening is protracted and the attainment of the ripe state is not associated with a marked increase in respiration or ethylene production.

Treatment of non climacteric fruits with ethylene stimulates respiration only; there is no increase in autocatalytic ethylene production. Fruits such as citrus, strawberries, and pineapples are non climacteric.

4. Write a short note on walk in freezer

Walk-in-Freezers (WIF):

- Walk-in-Freezer is a pre-fabricated modular Polyurethane foam (PUF) insulated panels assembled cold room with two identical Refrigeration units
- Standby generator set to provide the uninterrupted power supply
- An alarm or hooter system is also provided to alert regarding temp excursion.
- WIF is used for bulk storage of OPV (Oral Polio Vaccine) and preparation of frozen ice packs
- WIF maintain a temperature between - 15°C to -25°C.
- WIF sizes are 16.5, 20, 32 and 40 Cubic meter.
- Walk-in-Freezers are usually installed at National, State & Regional vaccine store.

Section – C

04X06 = 24 Marks

1. Explain all the terms required for load estimation for cold storages in detail.
To calculate the heat load for cold room/Storage, Following is to be considered:
 1. Transmission Load
 2. Product Load
 3. Occupancy Load
 4. Lighting Load
 5. Infiltration Load
 6. Equipment Load

1. Transmission Load

$$Q = U \cdot A \cdot (\text{Outside Temperature} - \text{Inside Temperature}) \cdot 24 / 1000$$

Where,

Q = Load (Kw-Hr/Day)

U = Overall Heat Transfer Coefficient (W/m²°C)

A = area (m²)

Temperature =(°C)

1000 W = 1 Kw

BHARTIYA SKILL DEVELOPMENT UNIVERSITY

24 Hours

2. Product Load

$$Q = M \cdot C_p \cdot (\text{Outside Temperature} - \text{Inside Temperature}) / (3600)$$

Where,

M = Mass (Kg)

C_p = Specific heat of product (Kj/Kg °C)

Temperature = (°C)

3600 Kj = 1 Kwh

3. Occupancy Load

$$Q = \text{persons} \cdot \text{Time} \cdot \text{Heat} / 1000$$

4. Lighting Load

$$Q = \text{Lamps} \cdot \text{Time} \cdot \text{Wattage} / 1000$$

5. Equipment Load

$$Q = \text{Fans} \cdot \text{Time} \cdot \text{Wattage} / 1000$$

6. Infiltration Load

$$Q = \text{Changes} \cdot \text{Energy} \cdot \text{Volume} \cdot (\text{Outside Temperature} - \text{Inside Temperature}) / 3600$$

Volume = Cubic meter

Energy = Kj/cm °C

2. Explain the post-harvest value chain for fruits and vegetables with the help of diagram in detail.

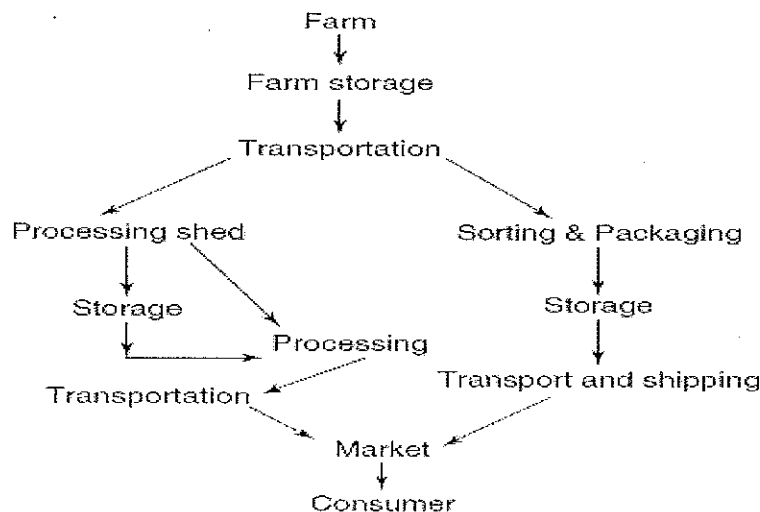

3. Following data given for a cold room:

Store Dimensions: 15mX10mX5m. Over all U Value - 0.35 w/sqm°C. Outside Design Conditions: 35°C DBT, 20°C WBT (Enthalpy = 66 KJ/Kg), Inside Design Conditions: 4°C+/-1°C, 75%RH (Enthalpy = 13 KJ/Kg). Product: Daily 2500Kg/24 hrs coming at 35°C with specific heat 3.0 KJ/Kg°C and 2APCH. Consider 4 men working for 4 hours daily. 4 fans are used of motor capacity 150 W each and run for 10 hours. 4 Lamps are used

BHARTIYA SKILL DEVELOPMENT UNIVERSITY

of capacity 50 W each and run for 5 hours. Each cubic meter of new air provides 2KJ/cm°C. Find out total load.

1. Transmission Load

$$Q = U \cdot A \cdot (\text{Outside Temperature} - \text{Inside Temperature}) \cdot 24/1000$$

$$= 138.6 \text{ Kwh/day}$$

2. Product Load

$$Q = M \cdot C_p \cdot (\text{Outside Temperature} - \text{Inside Temperature}) / (3600)$$

$$= 62.5 \text{ Kwh/day}$$

3. Occupancy Load

$$Q = \text{persons} \cdot \text{Time} \cdot \text{Heat} / 1000$$

$$= 4 \text{ Kwh/day}$$

4. Lighting Load

$$Q = \text{Lamps} \cdot \text{Time} \cdot \text{Wattage} / 1000$$

$$= 1 \text{ Kwh/day}$$

5. Equipment Load

$$Q = \text{Fans} \cdot \text{Time} \cdot \text{Wattage} / 1000$$

$$= 6 \text{ Kwh/day}$$

6. Infiltration Load

$$Q = \text{Changes} \cdot \text{Energy} \cdot \text{Volume} \cdot (\text{Outside Temperature} - \text{Inside Temperature}) / 3600$$

$$= 44.1 \text{ Kwh/day}$$

Therefore,

Total Load = Sum of all loads:

256 Kwh/day ans.

4. A cold storage of dimension 10mx5mx3m. Outside and inside temperatures are 30°C and 6°C, while the floor temperature is 8°C. Overall heat transfer coefficient is 0.37 w/sqm°C. 2500 Kgs of apple are to be stored and 4 people work daily for four hours inside the cold storage and each person generates heat of 270 W. Specific heat of apple is 2.2 kJ kg⁻¹ °C⁻¹. Enthalpy at 30°C DBT and 18.5°C WBT is 63 KJ/Kg of da. Enthalpy at 6°C and 90% RH is 20 KJ/Kg of da. 4 fans are used of motor capacity 120 W each and run for 10 hours. 4 Lamps are used of capacity 100 W each and run for 5 hours. Find out total load of storage (Consider 2 ACPH and respiration rate of product is 9.1 KJ/Kg/day).

1. Transmission Load

$$Q = U \cdot A \cdot (\text{Outside Temperature} - \text{Inside Temperature}) \cdot 24/1000$$

**BHARTIYA SKILL DEVELOPMENT UNIVERSITY**

$$= 0.37 \times 140(30-6)24/1000$$

$$= 29.8 \text{ Kwh/day.}$$

For floor,

$$= 0.37 \times 50(30-8)24/1000$$

$$= 9.8 \text{ Kwh/day}$$

$$\text{Total Transmission Load} = 29.8 + 9.8 = 39.6 \text{ Kwh/day}$$

2. Product Load

$$Q = M \times C_p \times (\text{Outside Temperature} - \text{Inside Temperature}) / (3600)$$

$$= 36.6 \text{ Kwh/day}$$

3. Occupancy Load

$$Q = \text{persons} \times \text{Time} \times \text{Heat} / 1000$$

$$= 4.3 \text{ Kwh/day}$$

4. Lighting Load

$$Q = \text{Lamps} \times \text{Time} \times \text{Wattage} / 1000$$

$$= 2 \text{ Kwh/day}$$

5. Equipment Load

$$Q = \text{Fans} \times \text{Time} \times \text{Wattage} / 1000$$

$$= 4.8 \text{ Kwh/day}$$

6. Infiltration Load

$$Q = \text{Changes} \times \text{Energy} \times \text{Volume} \times (\text{Outside Temperature} - \text{Inside Temperature}) / 3600$$

$$= 4.3 \text{ Kwh/day}$$

7. Respiration load

$$Q = \text{Mass} \times \text{Respiration rate} / 3600$$

$$= 6.3 \text{ Kwh/day}$$

Therefore,

$$\text{Total Load} = \text{Sum of all loads} = 98 \text{ Kwh/day}$$