



BHARTIYA SKILL DEVELOPMENT UNIVERSITY

Registration No.:

School of Refrigeration and Air-conditioning Skills

Session: 2021-22 (Winter Semester)

B. Voc. Program, V Semester,

2nd In-Sem. Examination

Course Code: HVA1501

Time: 1 Hour

Course Name: Heat Load Estimation

Max. Marks: 20

Section – A

05*01 = 05 Marks

Note: Each question carries 01 mark.

Q. 1: R value depends upon:

- | | |
|-------------------------|----------------------|
| A. Thermal conductivity | B. Length |
| C. Infiltration | D. None of the above |

Q. 2: Providing a _____ at entrances can help reduce infiltration.

- | | |
|------------|----------------------|
| A. Awning | B. Slat screen |
| C. Airlock | D. None of the above |

Q. 3: Stack effect happens in building above _____ floor.

- | | |
|-----------|-----------|
| A. Single | B. Double |
| C. Triple | D. Four |

Q. 4: Mechanically bringing in outside air by controlling the amount of air replacement is called:

- | | |
|-----------------|----------------------|
| A. Infiltration | B. Ventilation |
| C. Exfiltration | D. None of the above |

Q. 5: Which of the following methods is not used to estimate infiltration?

- | | |
|----------------------------|---------------------------|
| A. ACPH | B. Effective leakage Area |
| C. Outside Air ventilation | D. None of the above |

Section – B

03*02 = 06 Marks

Note: Each question carries 02 mark.

Q. 1: What is zoning and why is it important?

Q. 2: Explain ventilation gains.

Q. 3: What is U-factor and how is it related to R value of a material?



BHARTIYA SKILL DEVELOPMENT UNIVERSITY

Section – C

03*03 = 09 Marks

Note: Each question carries 03 mark.

- Q. 1: What is effective leakage area method?
- Q. 2: Explain the difference between wind and stack effects.
- Q. 3: How do you calculate conduction heat gain/losses?



BHARTIYA SKILL DEVELOPMENT UNIVERSITY

Registration No.:

School of Refrigeration and Air-conditioning Skills

Session: 2021-22 (Winter Semester)

B. Voc. Program, V Semester,
2nd In-Sem. Examination

Course Code: HVA1501

Course Name: Heat Load Estimation

Time: 1 Hour

Max. Marks: 20

Section – A

05*01 = 05 Marks

05 objective type questions, each question carries 01 mark.

Q. 1: B

Q. 2: A

Q. 3: D

Q. 4: C

Q. 5: C

Section – B

03*02 = 06 Marks

3 short answer type questions, each question carries 02 marks.

1. A zone is particularly that area of the building that is continuously subjected to variation in thermal load. For example, the areas near a window which is under continuous change in temperature due to variation of heat from the sun.
2. Some HVAC systems control this problem by mechanically bringing in outside air by controlling the amount of air replacement. By controlling this amount of exhaust air and maintaining a consistent flow, in both exhausting and air changes, a known amount of infiltration is controlled.

3. The U-factor is more commonly used to describe thermal conductivity in HVACR load calculations

A U-factor is assigned for a material of a given thickness

For example 2" foam board has an u-factor of .1

The smaller the U-factor the lower the conductivity and the higher the R value The rate of heat loss via conduction for a given building panel is calculated by the

formula: $Q = U\text{-factor} \times \text{Area} \times \Delta t$

Section – C

03*03 = 09 Marks

03 essay type questions, each question carries 03 marks.



BHARTIYA SKILL DEVELOPMENT UNIVERSITY

1. The second method to determine the rate of air infiltration is based on the effective leakage area of various construction components used in both residential and commercial buildings.

To obtain the building's total leakage area, multiply the overall dimensions or number of occurrences of each building component by the Leakage related to them.

Using the effective leakage area, the air flow rate due to infiltration is calculated.

2. Hot air rises through the building and escapes through cracks in the top ceiling. This causes cold outside air to be drawn in low (around the sole plate, basement windows or crawlspace access).

While some outside air is necessary for fired equipment that is usually located in the basement (dryer, water heater, furnace, etc.), it is better to provide this air directly to the mechanical room.

This helps to reduce drafts in the building caused by these devices. This stack effect becomes very pronounced in high-rise buildings, often causing noisy elevator and stair doors, where air is drawn into (or out of) these vertical shafts.

While stack effect cannot be eliminated, it can be reduced through careful design and it is usually not dominant in buildings under four stories tall.

3.

$$Q = A \left(\frac{k}{\Delta x} \right) (\Delta T)$$

where:

Q = rate of heat transfer through the material (Btu/hr)

k = thermal conductivity of the material (Btu/°F • hr • ft)

Δx = thickness of the material in the direction of heat flow (ft)

ΔT = temperature difference across the material (°F)

A = area heat flows across (ft²)



BHARTIYA SKILL DEVELOPMENT UNIVERSITY

School of RAC Skills

V Semester, 2nd In-Sem. Examination

B. Voc. Program, Winter Semester (2022-23)

Course Code: HVA1502

Time: 1 Hour

Course Name: Cold Chain & Cold Storage

Max. Marks: 20

Instruction:

1. Attempt all Questions.
2. Scientific calculator allowed.
3. Psychrometry chart is allowed.
4. Each question of Section – A carries 01 mark.
5. Each question of Section – B carries 02 mark.
6. Each question of Section – C carries 03 mark.

Section – A

05X01 = 05 Marks

1. Which source play a major role in a cold storage.
 - a. Transmission Load
 - b. Product Load
 - c. Infiltration Load
 - d. None of the above
2. What is the approx. storage temperature for fish?
 - a. -20 °C
 - b. -25 °C
 - c. -30 °C
 - d. none of the above
3. LIFO stands for-.
 - a. Last in first out
 - b. Late in first out
 - c. Low in full out
 - d. None of the above
4. Psychrometry is the study of-
 - a. moist air
 - b. stasis point
 - c. metrics in Canada
 - d. none of the above
5. In which direction cold air spills out?
 - a. Upward
 - b. Downward
 - c. Horizontal
 - d. None of the above

**BHARTIYA SKILL DEVELOPMENT UNIVERSITY****Section – B**

03X02 = 06 Marks

1. Write down the different sources of load gain in cold storages.
2. A cold Store with Dimension 10mX5mX4m. U Value for Walls- 0.24. Outside Design Conditions: 39°C DBT, 25°C WBT. Inside Design Conditions: 4°C, 75% RH Product: Daily 2500Kg/24 hrs coming at 30°C. Consider 2 men working for 4 hours daily. Find out the Load.
3. A cold room of size 20mx15mx8m. Outside and inside temperatures are 30°C and 6°C, while the floor temperature is 8°C. Overall heat transfer coefficient is 0.37 w/sqm°C. 5000 Kgs of apple are to be stored and 4 people work daily for four hours inside the cold storage and each person generates heat of 270 W. find out the sum of occupancy and product load. (use specific heat of apple $2.2 \text{ kJ kg}^{-1} \text{ }^\circ\text{C}^{-1}$).

Section – C

03X03 = 09 Marks

1. Following data given for a cold room:
Store Dimensions: 15mX10mX5m. Over all U Value - 0.35 w/sqm°C. Outside Design Conditions: 35°C DBT, 20°C WBT (Enthalpy = 66 KJ/Kg), Inside Design Conditions: 4°C +/- 1°C, 75%RH (Enthalpy = 13 KJ/Kg). Product: Daily 2500Kg/24 hrs coming at 35°C with specific heat 3.0 KJ/Kg°C and 2APCH. Consider 4 men working for 4 hours daily. Each cubic meter of new air provides 2KJ/cm°C. Find out total load.
2. A cold room with dimension 10mX8mX6m. Over all U Value - 0.35 w/sqm°C. Outside Design Conditions: 35°C DBT, 20°C WBT (Enthalpy = 66 KJ/Kg), Inside Design Conditions: 5°, 75%RH. Daily 2000Kg/24 hrs coming at 35°C with specific heat 3.0 KJ/Kg°C and 4 APCH. Each cubic meter of new air provides 2KJ/cm°C. Consider 4 fan motors rated 250 w working for 10 hours daily. Find out total load.
3. Following data given for a cold room:
Store Dimensions: 10mX6mX3m
Over all U Value - 0.24 w/sqm°C
Outside Conditions: 40°C DBT, 25°C WBT
Inside Conditions: 5°C, 75%RH
Person: 5 for 5 hours daily working inside
Lamps: 4 of 200 w each and used for 5 hours daily.
By using above data find out total load.



BHARTIYA SKILL DEVELOPMENT UNIVERSITY

School of RAC Skills

V Semester, 2nd In-Sem. Examination

B. Voc. Program, Winter Semester (2022-23)

Course Code: HVA1502

Time: 1 Hour

Course Name: Cold Chain & Cold Storage

Max. Marks: 20

Instruction:

Section – A

05X01 = 05 Marks

1. Which source play a major role in a cold storage.
 - a. Transmission Load
2. What is the approx. storage temperature for fish?
 - b. -25 °C
3. LIFO stands for-.
 - a. Last in first out
4. Psychrometry is the study of-
 - a. moist air
5. In which direction cold air spills out?
 - b. Downward

Section – B

03X02 = 06 Marks

- 1: Write down the different sources of load gain in cold storages.

Answer: Following are the load sources:

- a) Transmission Load
- b) Product Load
- c) Occupancy Load
- d) Lighting Load
- e) Infiltration Load
- f) Equipment Load
- g) Respiration Load

2. A cold Store with Dimension 10mX5mX4m. U Value for Walls- 0.24. Outside Design Conditions: 39°C DBT, 25°C WBT. Inside Design Conditions: 4°C, 75% RH Product: Daily 2500Kg/24 hrs coming at 30°C with specific heat capacity 2.5 kJ kg⁻¹ °C⁻¹. Consider 2 men working for 4 hours daily. Find out the Load.

Answer: Transmission Load

$$Q = U * A * (\text{Outside Temperature} - \text{Inside Temperature}) * 24 / 1000$$
$$= 0.24 * 220(39-4) * 24 / 1000$$

**BHARTIYA SKILL DEVELOPMENT UNIVERSITY**

total transmission load = 44.3 Kwh/Day

Product Load

$$Q = M * C_p * (\text{Outside Temperature} - \text{Inside Temperature}) / (3600)$$

$$= 45.1 \text{ Kwh/Day}$$

Occupancy Load

$$Q = \text{persons} * \text{Time} * \text{Heat} / 1000$$

$$= 4 \text{ Kwh/Day}$$

Total Load = 93.4 Kwh/Day ans.

3. A cold room of size 20mx15mx8m. Outside and inside temperatures are 30°C and 6°C. Overall heat transfer coefficient is 0.37 w/sqm°C. 5000 Kgs of apple are to be stored and 4 people work daily for four hours inside the cold storage and each person generates heat of 270 W. find out the sum of occupancy and product load. (use specific heat of apple 2.2 kJ kg⁻¹ °C⁻¹).

Answer: Transmission Load

$$Q = U * A * (\text{Outside Temperature} - \text{Inside Temperature}) * 24 / 1000$$

$$= 0.37 * 1160 (30 - 6) * 24 / 1000$$

total transmission load = 247 Kwh/Day

Product Load

$$Q = M * C_p * (\text{Outside Temperature} - \text{Inside Temperature}) / (3600)$$

$$= 73.3 \text{ Kwh/Day}$$

Occupancy Load

$$Q = \text{persons} * \text{Time} * \text{Heat} / 1000$$

$$= 4.32 \text{ Kwh/Day}$$

Total Load = 324.62 Kwh/Day ans.

Section – C

03X03 = 09 Marks

1. Following data given for a cold room:
Store Dimensions: 15mX10mX5m. Over all U Value - 0.35 w/sqm°C. Outside Design Conditions: 35°C DBT, 20°C WBT (Enthalpy = 66 KJ/Kg), Inside Design Conditions: 4°C+/-1 °C, 75%RH (Enthalpy = 13 KJ/Kg). Product: Daily 2500Kg/24 hrs coming at 35°C with specific heat 3.0 KJ/Kg°C and 2APCH. Consider 4 men working for 4 hours daily. Each cubic meter of new air provides 2KJ/cm°C. Find out total load.

Answer: Transmission Load

$$Q = U * A * (\text{Outside Temperature} - \text{Inside Temperature}) * 24 / 1000$$

$$= 0.35 * 550 (35 - 4) * 24 / 1000$$

total transmission load = 143 Kwh/Day

**BHARTIYA SKILL DEVELOPMENT UNIVERSITY****Product Load**

$$Q = M \cdot C_p \cdot (\text{Outside Temperature} - \text{Inside Temperature}) / (3600)$$

$$= 64.5 \text{ Kwh/Day}$$

Occupancy Load

$$Q = \text{persons} \cdot \text{Time} \cdot \text{Heat} / 1000$$

$$= 4 \text{ Kwh/Day}$$

Infiltration Load

$$Q = \text{Changes} \cdot \text{Energy} \cdot \text{Volume} \cdot (\text{Outside Temperature} - \text{Inside Temperature}) / 3600$$

$$= 25.8 \text{ Kwh/Day}$$

$$\text{Total Load} = 237.3 \text{ Kwh/Day ans.}$$

- 2: A cold room with dimension 10mX8mX6m. Over all U Value - 0.35 w/sqm°C. Outside Design Conditions: 35°C DBT, 20°C WBT (Enthalpy = 66 KJ/Kg), Inside Design Conditions: 5°, 75%RH. Daily 2000Kg/24 hrs coming at 35°C with specific heat 3.0 KJ/Kg°C and 4 APCH. Each cubic meter of new air provides 2KJ/cm°C. Consider 4 fan motors rated 250 w working for 10 hours daily. Find out total load.

Answer: Transmission Load

$$Q = U \cdot A \cdot (\text{Outside Temperature} - \text{Inside Temperature}) \cdot 24 / 1000$$

$$= 0.35 \cdot 376 \cdot (35 - 5) \cdot 24 / 1000$$

$$\text{total transmission load} = 94.7 \text{ Kwh/Day}$$

Product Load

$$Q = M \cdot C_p \cdot (\text{Outside Temperature} - \text{Inside Temperature}) / (3600)$$

$$= 50 \text{ Kwh/Day}$$

Equipment Load

$$Q = \text{Fan} \cdot \text{Time} \cdot \text{Watt} / 1000$$

$$= 10 \text{ Kwh/Day}$$

Infiltration Load

$$Q = \text{Changes} \cdot \text{Energy} \cdot \text{Volume} \cdot (\text{Outside Temperature} - \text{Inside Temperature}) / 3600$$

$$= 32 \text{ Kwh/Day}$$

$$\text{Total Load} = 186.7 \text{ Kwh/Day ans.}$$

**BHARTIYA SKILL DEVELOPMENT UNIVERSITY**

3. Following data given for a cold room:
Store Dimensions: 10mX6mX3m
Over all U Value - 0.24 w/sqm°C
Outside Conditions: 40°C DBT, 25°C WBT
Inside Conditions: 5°C, 75%RH
Person: 5 for 5 hours daily working inside
Lamps: 4 of 200 w each and used for 5 hours daily.
By using above data find out total load.

Answer: Transmission Load

$$Q = U \cdot A \cdot (\text{Outside Temperature} - \text{Inside Temperature}) \cdot 24/1000$$
$$= 0.24 \cdot 360(40-5) \cdot 24/1000$$

total transmission load = 207.4 Kwh/Day

Occupancy Load

$$Q = \text{persons} \cdot \text{Time} \cdot \text{Heat}/1000$$
$$= 6.2 \text{ Kwh/Day}$$

Equipment Load

$$Q = \text{Fan} \cdot \text{Time} \cdot \text{Watt}/1000$$
$$= 4 \text{ Kwh/Day}$$

Total Load = 237.3 Kwh/Day ans.



BHARTIYA SKILL DEVELOPMENT UNIVERSITY

Registration No.:

School of Refrigeration and Air-conditioning Skills

Session: 2021-22 (Winter Semester)

B. Voc. Program, V Semester,

2nd In-Sem. Examination

Course Code: HVA1503

Time: 1 Hour

Course Name: Chilled water supply system design

Max. Marks: 20

Section – A

05*01 = 05 Marks

Note: Each question carries 01 mark.

Q. 1: Which of the following is not a fully saturated organic refrigerant?

- A. R-11
- C. R32

- B. R-134a
- D. R-717

Q. 2: Which of the following compressor type is nonexistent in modern chillers?

- A. Reciprocating
- C. Scroll

- B. Screw
- D. Rotary

Q. 3: Which of the following compressors is used for small scale chillers?

- A. Reciprocating
- C. Scroll

- B. Screw
- D. Rotary

Q. 4: Which of the following refrigerant is used in negative pressure compressor

- A. R-32
- C. R-123

- B. R-134a
- D. R-410A

Q. 5: R-1233zd is a replacement for

- A. NH₃
- C. R-12

- B. CO₂
- D. R-123

Section – B

03*02 = 06 Marks

Note: Each question carries 02 mark.

Q. 1: What are inorganic refrigerants?

Q. 2: Explain the difference between zeotropic and azeotropic refrigerants.

Q. 3: What are the advantages of scroll compressors over reciprocating?



BHARTIYA SKILL DEVELOPMENT UNIVERSITY

Section – C

03*03 = 09 Marks

Note: Each question carries 03 mark.

- Q. 1: Why is R-134a preferred over any other refrigerant for chillers?
- Q. 2: Write a comparison between single screw and twin screw compressors.
- Q. 3: What are HFOs and what changes do they bring?



BHARTIYA SKILL DEVELOPMENT UNIVERSITY

Registration No.:

School of Refrigeration and Air-conditioning Skills

Session: 2021-22 (Winter Semester)

B. Voc. Program, V Semester,

2nd In-Sem. Examination

Course Code: HVA1503

Course Name: Chilled water supply system design

Time: 1 Hour

Max. Marks: 20

Section – A

05*01 = 05 Marks

05 objective type questions, each question carries 01 mark.

Q. 1: B

Q. 2: D

Q. 3: A

Q. 4: C

Q. 5: A

Section – B

03*02 = 06 Marks

3 short answer type questions, each question carries 02 marks.

1:

Ans. Inorganic refrigerants consists of inorganic compounds (which does not contain carbon-hydrogen bond) used primarily as refrigerants such as R718, 717, and 744. Majority of these refrigerants are non-toxic and are environment friendly, inexpensive & non-flammable.

2:

Ans. Azeotropic and zeotropic mixtures have different dew and bubble curves characteristics in a temperature-composition graph. Namely, azeotropic mixtures have dew and bubble curves that intersect, but zeotropic mixtures do not. In other words, zeotropic mixtures have no azeotropic points.

3

Ans. Scroll compressors are 10-15 percent more efficient than reciprocating and are proven very reliable because they have approximately 60 percent less moving parts.

Section – C

03*03 = 09 Marks

03 essay type questions, each question carries 03 marks.



BHARTIYA SKILL DEVELOPMENT UNIVERSITY

Ans.1

- As a refrigerant, it possesses completely stable thermal characteristics, has low toxicity, and is non-corrosive and non-combustible. It is widely used in car air-conditioning units as well as industrial chiller units. Additionally, R134A HFC has minimal ozone depletion potential with a near-zero GWP

Ans2.

- The single screw consists of a single cylindrical main rotor that works with a pair of gate rotors.
- The compressor is driven through the main rotor shaft, and the gate rotors, followed by direct meshing action.
- Single-screw compressors are noted for long bearing life, as the bearing loads are inherently balanced.
- The twin screw is also known as a *double helical rotary screw*.
- The twin screw consists of two mating helically grooved rotors, one male and the other female.
- Either the male or female rotor can be driven.
- In addition to excellent part-load and part-lift performance, these chillers offer significantly reduced noise and wear at off-design conditions.

Ans3.

- HFOs (hydrofluoro-olefins) are the fourth generation of fluorine-based gases. HFC refrigerants are composed of hydrogen, fluorine and carbon atoms connected by single bonds between the atoms. HFO refrigerants are composed of hydrogen, fluorine and carbon atoms but contain at least one double bond between the carbon atoms.



BHARTIYA SKILL DEVELOPMENT UNIVERSITY

Registration No.:

School of Refrigeration & Air conditioning Skills

Session: 2021-22 (Winter Semester)

B. Voc. Program, V-Semester,
2nd In-Sem. Examination

Course Code: HVA 1504

Time: 1 Hour

Course Name: AC system and testing

Max. Marks: 20

Instruction: Read the question carefully, do attempt all

Section – A

05*01 = 05 Marks

Q1) Ratio of maximum dimension to minimum dimension is known as?

- a. Aspect ratio
- b. possession ratio
- c. Pressure ratio
- d. dimension ratio

Q2) ducting is classified according to _____?

- a. Shapes
- b. pressure
- c. velocity
- d. all of the above

Q3) Friction value of chart is taken per _____ ft of duct length?

- a. 100
- b. 200
- c. 10
- d. 50

Q4) Duct with high pressure have _____ friction value of?

- a. 6.5 to 12.25
- b. 3.5 to 4.25
- c. 2.5 to 8.25
- d. 1 to 3.25

Q5) Evaporators of chillers are _____ categories as?

- a. Shell and tube
- b. PHE
- c. Coil and tube
- d. all of the above

Section – B

03*02 = 06 Marks

Q1) Write down the name of duct sizing methods.

Q2) Mention the various types of pressure in the duct system with their application?

Q3) Explain duct components with neat sketch?

Section – C

03*03 = 09 Marks

Q1) Write types of duct materials along with application?

Q2) Explain converging, diverging and constant cross-sectional areas with neat sketch?

Q3) Explain round shape and rectangular shape duct?

Shubh J.

2



BHARTIYA SKILL DEVELOPMENT UNIVERSITY

Registration No.:

School of Refrigeration & Air conditioning Skills

Session: 2021-22 (Winter Semester)

B. Voc. Program, V-Semester,

2nd In-Sem. Examination

Course Code: HVA 1504

Time: 1 Hour

Course Name: AC system and testing

Max. Marks: 20

Answer key

Section – A

5*01 = 05 Marks

- A1) A
- A2) D
- A3) A
- A4) A
- A5) D

Section – B

03*02 = 06 Marks

A 1. Write down the name of duct sizing methods.

1. Equal friction method
2. Velocity reduction method
3. static regain method

A 2. Mention the various types of pressure in the duct system with their application?

Duct system is pressurized by three pressures:

- Static pressure: It is the air pressure in the duct, which is used for fan selection.
- Velocity pressure: It is the pressure generated by the velocity and weight of the air, which is used for measuring the flow (cfm) in a system.
- Total pressure: It is used to find velocity pressure. Static pressure plus velocity pressure equals total pressure.

Pressure in the ductwork is measured in inches of water column (in-wc).

A 3. Explain duct components with neat sketch?

1. Supply air ductwork supplies conditioned air from the air handling unit to the conditioned area.
2. Return air ductwork removes air from the conditioned building spaces and returns the air to the air handling unit, which reconditions the air. In some cases, part of the return air in this ductwork is exhausted to the building exterior.
3. Fresh air ductwork supplies outdoor air to the air handling unit. Outdoor air is used for ventilating the occupied building space.
4. Exhaust (relief) air ductwork carries and discharges air to the outdoors. Exhaust air is taken from toilets, kitchen, laboratories and other areas requiring ventilation.

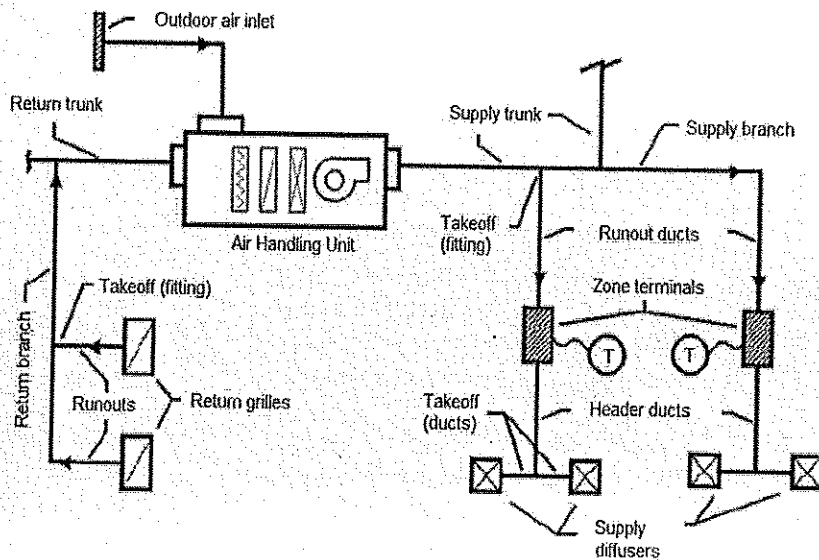

Section – C

03*03 = 09 Marks

A 1. Write types of duct materials along with application?

1. Galvanized Steel: It is a standard, most common material used in fabricating ductwork for most comfort air conditioning systems.
2. Aluminum: It is widely used in clean room applications. These are also preferred systems for moisture laden air, special exhaust systems and ornamental duct systems.
3. Stainless Steel: It is used in duct systems for kitchen exhaust, moisture laden air, and fume exhaust.
4. Copper: It is mainly used for certain chemical exhaust and ornamental ductwork.
5. Fiber-glass Reinforced Plastic (FRP)
6. PVC
7. Fabric

A 2. Explain converging, diverging and constant cross-sectional areas with neat sketch?

Static and velocity pressure are mutually convertible. The magnitude of each is dependent on the local duct cross-section which determines the flow velocity. The following pressure changes are affected in the ducts:

- **Constant cross-sectional areas:** Total and static losses are equal.
- **Diverging sections (increase in duct size):** Velocity pressure decreases, total pressure decreases, and static pressure may increase (static regain).
- **Converging sections (decrease in duct size):** Velocity pressure increases in the direction of flow, total and static pressure decrease.

A 3. Explain round shape and rectangular shape duct?

Round Ducts

The duct shape that is the most efficient (offers the least resistance) in conveying moving air is a round duct, because it has the greatest cross-sectional area and a minimum contact surface.



BHARTIYA SKILL DEVELOPMENT UNIVERSITY

In other words, it uses less material compared to square or rectangular ducts for the same volume of air handled.



Round Duct

Some of the advantages of round ductwork include:

- Round shape results in lower pressure drops, thereby requiring less fan horsepower to move the air and, consequently, smaller equipment.
- Round shape also has less surface area and requires less insulation when externally wrapped.
- Round ducts are available in longer lengths than rectangular ducts, thereby eliminating costly field joints. Spiral lock-seams add rigidity; therefore, spiral ducts can be fabricated using lighter gauges than longitudinal seam ducts. Spiral ducts leak less and can be more easily sealed compared to rectangular ducts.
- The acoustic performance of round and oval ducts is superior because their curved surfaces allow less breakout noise. The low-frequency sound is well contained in round ducts.

Rectangular Ducts

Square or rectangular ducts fit better to building construction. They fit above ceilings and into walls, and they are much easier to install between joists and studs.

When rectangular ducts must be used due to space limitations, keep the width-to-height ratio (aspect ratio) low. A rectangular duct section with an aspect ratio close to 1 yields the most efficient rectangular duct shape in terms of conveying air. A duct with an aspect ratio above 4 is much less efficient in use of material and experiences great pressure losses. Aspect ratios of 2 to 3 are ideal in trading off added duct cost of material and fan energy for headroom savings.

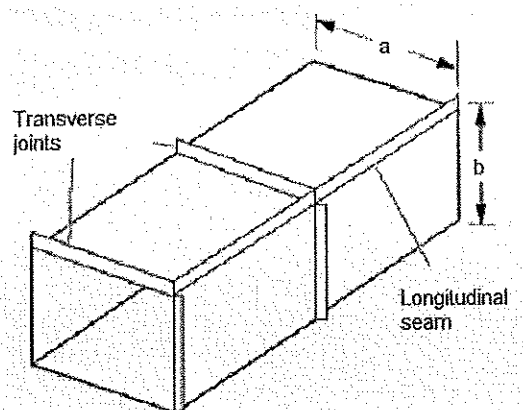

Sheela J.

