



BHARTIYA SKILL DEVELOPMENT UNIVERSITY

School of General Education

Session: 2019-20 (Summer Semester)

B. Voc. Program, 3rd Semester,

End-Sem. Examination

Course Code: GEN 1301

Time: 2 Hours

Course Name: Spoken English

Max. Marks: 50

Instruction: The question paper comprises three sections A, B & C. Attempt all questions.

Marks allotted are mentioned against each section.

Section – A

10X01 = 10 Marks

Q1. The Snake in the short story *Snake in the Grass* belonged to the _____ family:

- | | |
|------------|---------------|
| (a) Cobra | (c) Viper |
| (b) Python | (d) Rat Snake |

Q2. The term *Virtue* means:

- (a) behavior showing high moral standard
- (b) behavior showing low, moral standard
- (c) behavior showing disgust
- (d) behavior showing hatred for other

Q3. The word 'woods' in the poem *Leisure* means:

- | | |
|------------|--------------|
| (a) Forest | (c) Sky |
| (b) Stream | (d) Sunlight |

Q4. Fill in the blank with the word from the poem 'Leisure'.

*No time to see, in broad daylight,
Streams full of , like skies at night:*

- | | |
|-----------|----------|
| (a) sight | (c) care |
| (b) stars | (d) snow |

Q5. Choose the correct answer for the indirect speech of the given sentence:

I said, "Renu plays well".

- (a) I said that Renu played well.
- (b) I said that Renu plays well.
- (c) I say that Renu played well.
- (d) I say that Renu plays well.

Q6. Change the following sentence from active to passive voice.

He buys a camera.

Q7. Fill in the blank with the correct modal verb:

You have not eaten the whole day. You be hungry.

- | | |
|------------|----------|
| (a) Can | (c) May |
| (b) Should | (d) Must |

Q8. Combination of two vowel sounds is:

- | | |
|-----------------|-----------------------|
| (a) Monophthong | (c) Consonant |
| (b) Diphthong | (d) Short vowel sound |

Q9. Fill in the blank with the opposite of the given word: *Kind*

- | | |
|------------|-----------|
| (a) Polite | (c) Sober |
| (b) Gentle | (d) Cruel |

- Q10. Fill in the blank with the correct option:
She can speak English,she? (can/can't)

Section – B

04X04 = 16 Marks

- Q11. Explain with reference to the context:
*Sweet day, so cool, so calm, so bright,
The bridal of the earth and sky;
The dew shall weep thy fall tonight,
For thou must die.*
- Q12. Make sentences with the following words:
(a) Beauty (c) Honest
(b) Bright (d) Angry
- Q13. Write a short summary of the poem 'Virtue'.
- Q14. Convert the given sentences into reported speech:
(a) He said, "Ram plays hockey".
(b) The teacher said, "India became independent in 1947".
(c) I said to her, "You can play".
(d) She said, "Rohan played well."

Section – C

04X06 = 24 Marks

- Q15. Write a short summary of the poem 'Leisure'.
- Q16. Write a paragraph on the given topic:

Skill Education – the need of the hour

- Q17. Draft a conversation in about 10-15 sentences between yourself and your teacher in a situation where you are requesting him for allowing you to submit the assignment after the due date.
- Q18. Read the following text and answer the questions given below:
There is a story of a man who thought he had a right to do what he liked. One day, this gentleman was walking along a busy road, spinning his walking-stick round and round in his hand, and was trying to look important. A man walking behind him objected. "You ought not to spin your walking-stick round and round like that!" he said. "I am free to do what I like with my walking-stick," argued the gentleman. "Of course you are," said the other man, "but you ought to know that your freedom ends where my nose begins."
The story tells us that we can enjoy our freedom only if they do not interfere with other people's rights and freedom.
- (a) Why was the gentleman on the road moving his walking stick round and round? (1)
(b) Who objected to him? (1)
(c) When can we enjoy our freedom? (1)
(d) Make a precis of the passage given above. (3)



Registration No.:

School of General Education
Session: 2019-20 (Summer Semester)
B. Voc. Program, III Semester,
End-Sem. Examination

Course Code: GEN1301

Time: 2 Hours

Course Name: Spoken English

Max. Marks: 50

Instruction: The question paper comprises three sections A, B & C. Marks allotted are mentioned against each section. Attempt *all* questions.

Section – A

10X01 = 10 Marks

Q1. The Snake in the short story *Snake in the Grass* belonged to the _____ family:

- (a) **Cobra**
- (b) Python
- (c) Viper
- (d) Rat Snake

Q2. The term *Virtue* means:

- (a) **behavior showing high moral standard**
- (b) behavior showing low, moral standard
- (c) behavior showing disgust
- (d) behavior showing hatred for other

Q3. The word 'woods' in the poem *Leisure* means:

- (a) **Forest**
- (b) Stream
- (c) Sky
- (d) Sunlight

Q4. Fill in the blank with the word from the poem 'Leisure'.

*No time to see, in broad daylight,
Streams full of, like skies at night:*

- (a) sight
- (b) **stars**
- (c) care
- (d) snow

Q5. Choose the correct answer for the indirect speech of the given sentence:

I said, "Renu plays well".

- (a) **I said that Renu played well.**
- (b) I said that Renu plays well.
- (c) I say that Renu played well.
- (d) I say that Renu plays well.



BHARTIYA SKILL DEVELOPMENT UNIVERSITY

Q6. Change the following sentence from active to passive voice.

(a) He buys a camera.

A camera is bought by him.

Q7. Fill in the blank with the correct modal verb :

You have not eaten the whole day. You be hungry.

(a) Can

(b) Should

(c) May

(d) Must

Q8. Combination of two vowel sounds is:

(a) Monophthong

(b) Diphthong

(c) Consonant

(d) Short vowel sound

Q9. Fill in the blank with the opposite of the given word: *Kind*

(a) Polite

(b) Gentle

(c) Sober

(d) Cruel

Q10. Fill in the blank with the correct option:

(a) She can speak English,she? (can/**can't**)

Section – B

04X04 = 16 Marks

Q11. Explain with reference to the context:

Sweet day, so cool, so calm, so bright,

The bridal of the earth and sky;

The dew shall weep thy fall tonight,

For thou must die.

Ans. The day is beautiful and bright and looks as beautiful as a bride. It will die and the sky will weep.

Q12. Make sentences with the following words:

(a) Beauty- **I admire the beauty of nature.**

(b) Bright- **The day is very bright.**

(c) Honest- **My friend is an honest person.**

(d) Angry- **My friend is angry with me today.**

Q13. Write a short summary of the poem 'Virtue'.

Ans. This poem is about the virtuous(good) soul that never dies. The day is beautiful and bright and looks as beautiful as a bride. It will die and the sky will weep. The rose is bright in colour and people cannot look at it for a long time. It will also die one day. The spring season is wonderful. Everything is bright and colourful. Even that will die one



BHARTIYA SKILL DEVELOPMENT UNIVERSITY

day. The poet says that a good soul will never die. It is like polished wood and even if everything else is dead, it will live.

Q14. Convert the given sentences in reported speech:

(a) He said, "Ram plays hockey".

He said that Ram played hockey.

(b) The teacher said, "India became independent in 1947".

The teacher said that India became independent in 1947.

(c) I said to her, "You can play".

I said to her that she could play.

(e) She said, "Rohan played well."

She said that Rohan had played well.

Section – C

04X06 = 24 Marks

Q15. Write a short summary of the poem 'Leisure'.

Ans. In this poem, 'Leisure', the poet William Davies is telling us about our hectic life. We have no time to admire the nature around us. Even we cannot spare a few moments to stand under the branches of green trees and enjoy the beautiful and restful shades of the trees. The common animals like sheep and cows are better than us in enjoying life. We cannot look at them grazing in the pastures/grasslands. When we pass through some forests, we do not have time to stop for some moments to look at the trees-tall and short, and enjoy their natural beauty. The dark green trees provide a soothing/calming effect but we are always hurried and cannot enjoy at least the simple beauty. Also we cannot look at the small animals like squirrels concealing/hiding their food-grain in the grass for the winter. During day time, when the rays of the sun fall upon the clear water of the rivers, the water reflects and shines like stars in the sky during night. But busy people do not have time to see this. The natural beauty is scattered all around us. Natural beauty is personified as a young beautiful dancing girl having a smiling face. But we have no time to stand at a place and look carefully at nature that can refresh us. As human beings, we should spare some moments and look at nature and natural beauty spread around us and enjoy life.

Q16. Write a paragraph on the given topic:

(a) Skill Education – the need of the hour

Ans. Skill Education – the need of the hour

Elaborate points on the Importance of skill development of this large working population is not a matter of great debate. It is not a choice but an imperative both for the nation and for the individual. From the nation's perspective, economic growth is dependent on productivity of industry and its people. People can be productive provided they enjoy good health, have access to quality education, relevant skills, and



BHARTIYA SKILL DEVELOPMENT UNIVERSITY

are made aware of livelihood opportunities presented by the economic growth around them

Q17. Draft a conversation in about 10-15 sentences between yourself and your teacher in a situation where you are requesting him for submitting the assignment late.

Ans. Exchanges between the student and teacher on Greetings, utterances of making apology, Justifying the reason, assuring submitting assignment on time in future, Thanking the principal.

Q18. Read the following text and answer the questions given below:

There is a story of a man who thought he had a right to do what he liked. One day, this gentleman was walking along a busy road, spinning his walking-stick round and round in his hand, and was trying to look important. A man walking behind him objected.

“You ought not to spin your walking-stick round and round like that!” he said.

“I am free to do what I like with my walking-stick,” argued the gentleman.

“Of course you are,” said the other man, “but you ought to know that your freedom ends where my nose begins.”

The story tells us that we can enjoy our freedom only if they do not interfere with other people’s rights and freedom.

(a) Why was the gentleman on the road moving his walking stick round and round? (1)
The gentleman on the road was moving his walking stick round and round because he wanted to look important.

(b) Who objected to him? (1)
A man walking behind him objected.

(c) When can we enjoy our freedom? (1)
We can enjoy our freedom only if they do not interfere with other people’s rights and freedom.

(d) Make a precis of the passage given above. (3)

Ans. Rights and Freedom: It is a story of a man who thought he could do what he liked. One day, he was walking along a busy road, spinning his walking-stick round and round in his hand. A man walking behind him objected and asked him not to do so but he said that he was free to do what he liked. The other man told him that we can enjoy our freedom only if they do not interfere with other people’s rights and freedom.



BHARTIYA SKILL DEVELOPMENT UNIVERSITY

B

Registration No.:

School of General Education
Session: 2019-20 (Summer Semester)
B. Voc. Program, 3rd Semester
End-Sem. Examination

Course Code: GEN1303

Time: 2 Hours

Course Name: Entrepreneurship Development (Introductory Module) Max. Marks: 50

Instruction: Attempt all questions.

Section – A

10 X 01 = 10 Marks

- Q.1. The definition of entrepreneurship holds the promise of...
- (a) Financial difficulties and hardship
 - (b) Limited expansion
 - (c) Growth, unlimited expansion, and long-term financial gain
 - (d) Growth, expansion, and long-term financial gain
- Q.2. The following are myths related to entrepreneurs.
- (a) Entrepreneurs are born not made
 - (b) Entrepreneurs are doers and not thinkers
 - (c) Entrepreneurs are risk-takers
 - (d) All of the above
- Q.3. The resistance of employees in an organization against flexibility, growth, and diversification can be overcome by developing _____?
- (a) Entrepreneurship
 - (b) Managerial Domain
 - (c) Intrapreneurship
 - (d) Administrative domain
- Q.4. Stand Up India Scheme is to promote entrepreneurship among:
- (a) Scheduled Caste/Scheduled Tribes (SC/ST)
 - (b) Women
 - (c) Minority
 - (d) All of the above
- Q.5. Which of the following is NOT studied in industry analysis?
- (a) Economic conditions
 - (b) Technology advancements
 - (c) Organizational culture
 - (d) Legal concerns
- Q.6. Why should an entrepreneur do a feasibility study for starting a new venture?
- (a) To see if there are possible barriers to success
 - (b) To identify possible sources of funds
 - (c) To estimate the expected sales
 - (d) To explore potential customers
- Q.7. The term 'Intellectual Property Rights' covers:
- (a) Copyrights
 - (b) Know-how
 - (c) Trade dress
 - (d) All of the above
- Q.8. Trademarks relate to _____:
- (a) Practice and knowledge acquired through experience
 - (b) The protection of proprietary information of commercial value



BHARTIYA SKILL DEVELOPMENT UNIVERSITY

- (c) The right to reproduce one's own original work
- (d) Brand identity

Q.9. How long do patents usually last for?

- (a) 10 years
- (b) 20 years
- (c) 40 years
- (d) 60 years

Q.10. LLC is more flexible than:

- (a) S Corporation
- (b) Limited Partnership
- (c) Sole Proprietor
- (d) All of the above

Section – B

04 X 04 = 16 Marks

- Q11.** What skills do you need to be an entrepreneur?
- Q12.** What are the common forms of businesses, and what structure makes the most sense for your new small business?
- Q13.** How start-up India is different from stand-up India? List out at least two salient features of these initiatives.
- Q14.** What do you mean feasibility study? Why it is important?

Section – C

04 X 06 = 24 Marks

- Q15.** “Self-employment is the best method of solving the problem of growing unemployment in the country.” Suggest a suitable strategy for the identification and development of entrepreneurs.
- Q16.** What is intellectual property? What are the types of intellectual property protection?
- Q17.** Describe entrepreneurial opportunity recognition & business idea generation approaches.
- Q18.** What is the institutional support system? How is the Rajasthan Government fostering start-ups and digital innovation through various institutional support system and govt. programs?



BHARTIYA SKILL DEVELOPMENT UNIVERSITY

Registration No.:

Sch - B

School of Entrepreneurship Skills
Session: 2019-20 (Summer Semester)
B. Voc. Program, III Semester
End-Sem. Examination
SET B

Time: 2 Hours

Max. Marks: 50

Course Code: GEN1303

Course Name: Entrepreneurship Development (Introductory Module)

Instruction: All questions are compulsory. Write answers legibly in English only.

Section – A

10 X 01 = 10 Marks

Note: 10 objective type questions, each question carries 01 mark

Q.1. The definition of entrepreneurship holds the promise of...

- a) Financial difficulties and hardship
- b) Limited expansion
- c) Growth, unlimited expansion and long-term financial gain
- d) **Growth, expansion and long-term financial gain**

Q.2. The following are myths related to entrepreneurs.

- a) Entrepreneurs are born not made
- b) Entrepreneurs are doers and not thinkers
- c) Entrepreneurs are risk takers
- d) **All of the above**

Q.3. The resistance of employees in an organization against flexibility, growth and diversification can be overcome by developing _____?

- a) Entrepreneurship
- b) Managerial Domain
- c) **Intrapreneurship**
- d) Administrative domain

Q.4. Stand Up India Scheme is to promote entrepreneurship among.

- a) Scheduled Caste/Scheduled Tribes (SC/ST)
- b) Women
- c) Minority
- d) **All of the above**

Q.5. Which of the following is NOT studied in industry analysis?

- a) Economic conditions
- b) Technology advancements
- c) Organizational culture
- d) **Legal concerns**

Q.6. Why should an entrepreneur do a feasibility study for starting a new venture?

- a) **To see if there are possible barriers to success**
- b) To identify possible sources of funds
- c) To estimate the expected sales
- d) To explore potential customers



BHARTIYA SKILL DEVELOPMENT UNIVERSITY

- Q.7. The term 'Intellectual Property Rights' covers
- Copyrights
 - Know-how
 - Trade dress
 - All of the above
- Q.8. Trademarks relate to _____.
- Practice and knowledge acquired through experience
 - The protection of proprietary information of commercial value
 - The right to reproduce ones own original work
 - Brand identity
- Q.9. How long do patents usually last for?
- 10 years
 - 20 years
 - 40 years
 - 60 years
- Q.10. LLC is more flexible than
- S Corporation
 - Limited Partnership
 - Sole Proprietor
 - All of the above

Section – B

04 X 04 = 16 Marks

Note: 04 short answer type questions, each question carries 04 marks.

Question-1 What skills do you need to be an entrepreneur?

When starting a business, we all come at from different directions, at different ages, different backgrounds. There are so many skills required to run your own startup.

Opportunity Recognition: The recognition of new markets and opportunities, such as a new customers' need is core to becoming a successful entrepreneur.

Research & Analysis: This involves both qualitative and quantitative data collection and analysis. Understanding the customers, competitors and costs structure are important in making a startup work.

Risk Analysis: This process of defining and analyzing the dangers to your startup business posed by potential natural and human-caused events.

Team Building: As a new business building a team is important, which requires various types of activities used to enhance social relations and define roles within team are developed and maintained.

Negotiating & Selling: Getting the right prices from your suppliers and selling at the right price is fundamental for a startup to grow. These skills go hand in hand together.

Question-2 What are the common forms of businesses, and what structure makes the most sense for your new small business?

The most common forms of businesses are:

Sole Proprietorships: A sole proprietorship is the most common form of business organization. It's easy to form and offers complete control to the owner. But the business owner is also personally liable for all financial obligations and debts of the business.



BHARTIYA SKILL DEVELOPMENT UNIVERSITY

Partnerships: A partnership is the relationship existing between two or more persons who join to carry on a trade or business. Each person contributes money, property, labor or skill, and expects to share in the profits and losses of the business.

Corporations: A corporate structure is more complex than other business structures. It requires complying with more regulations and tax requirements.

Limited Liability Companies (LLC): A Limited Liability Company (LLC) is a relatively new business structure allowed by state statute. LLCs are popular because, similar to a corporation, owners have limited personal liability for the debts and actions of the LLC.

One of the first decisions that small business owner needs to take is what form of business he/she want to have. This decision is very important because it can affect how much you pay in taxes, the amount of paperwork your business is required to do, the personal liability you face and your ability to borrow money. A sole proprietorship is the most common form of business organization. It's easy to form and offers complete control to the owner. But the business owner is also personally liable for all financial obligations and debts of the business. The flexibility of an LLC—and protection of personal assets—makes LLCs a popular choice for small business owners.

Question-3 How start-up India is different from stand-up India? List out at least two salient features of these initiatives.

Start-up India and Stand-up India are both initiatives by the government to usher entrepreneurship in the country. Stand Up India Scheme is to promote entrepreneurship among SC/ST and Women entrepreneurs. Whereas Start Up India scheme is to promote new ventures/initiatives (Making Legal Registration Process Quick)

Salient features of Stand-Up India:

- The scheme will facilitate two entrepreneurial projects on an average one for each category (Women and SC/ST) of entrepreneurs per bank branch.
- The scheme will provide financial aid through SIDBI with an initial amount of Rs 10,000 crore.

Salient features of Start-Up India:

- Single window clearance with modified and more friendly bankruptcy code to ensure 90-day exit window.
- 10,000 crore fund of funds with 80% reduction in patent registration fee.

Question-4 What do you mean feasibility study? Why it is important?

As the name implies, a feasibility analysis is used to determine the viability of an idea, such as ensuring a project is legally and technically feasible as well as economically justifiable. It tells us whether a project is worth the investment—in some cases, a project may not be doable. There can be many reasons for this, including requiring too many resources, which not only prevents those resources from performing other tasks but also may cost more than an organization would earn back by taking on a project that isn't profitable.

The importance of a feasibility study is based on organizational desire to “get it right” before committing resources, time, or budget. A feasibility study might uncover new ideas that could completely change a project's scope. It's best to make these determinations in advance, rather than to jump in and to learn that the project won't work. Conducting a feasibility study is always beneficial to the project as it gives you and other stakeholders a clear picture of the proposed project.

Section – C

04 X 06 = 24 Marks

Note: 04 long type questions, each question carries 06 marks.



BHARTIYA SKILL DEVELOPMENT UNIVERSITY

Question-1 "Self-employment is the best method of solving the problem of growing unemployment in the country." Suggest a suitable strategy for the identification and development of entrepreneurs.

To counter the unemployment problems in the country government, have to take some serious steps, that can foster and incentivize entrepreneurship in the country which in turn reduce the unemployment.

Following are suggested suitable strategy to address the issue:

1. Easy permissions to private sector companies - Govt. should start giving single window permissions to more private companies because of Govt. cannot employ every person in the county. Private sector companies can help in it.
2. Lowering the taxes on business - Govt. have to lower the taxes so that more business can get a chance to spread its roots.
3. Providing loans to business- When Govt. start providing loans to the business, current capital can raise and new business will get the capital which they need to start the business.
4. Inviting foreign companies - To increase the employment Govt. can invite foreign companies to open their factories in the country.
5. Allowing FDI - Not having enough capital to expand their business can be a major factor for many companies. When Govt. allow FDI then companies can get the capital which they wanted to expand.
6. Flexibility in law - Govt. should make some changes in the law as there can be many laws that can be helpful for the country but not for the business.

Question-2 What is intellectual property? What are the types of intellectual property protection?

Intellectual property (IP) refers to creations of the mind, such as inventions; literary and artistic works; designs; and symbols, names and images used in commerce. There are many types of intellectual property, and some countries recognize more than others. The most well-known types are copyrights, patents, trademarks, and trade secrets.

Intellectual Property Protection:

Intellectual Property Protection is protection for inventions, literary and artistic works, symbols, names, and images created by the mind. Entrepreneurs and business owners need to understand the basics of intellectual property (IP) law to best protect their hard-earned creations and ideas from unfair competition. Four major types of IP protection include:

Patent: It is used to protect inventive ideas or processes – things that are new, useful and nonobvious. Patents are what most often come to mind when thinking of IP protection. Patents are also used to protect newly engineered plant species or strains, as well. There are three type of patents viz. Utility, Design, Plant.

Trademark: A trademark is unlike a patent in that it protects words, phrases, symbols, sounds, smells and color schemes. Trademarks are often considered assets that describe or otherwise identify the source of underlying products or services that a company provides, such as the MGM lion roar, the Home Depot orange color scheme, the Intel Inside logo, and so on.

Copyright: It do not protect ideas, but rather the manner in which ideas are expressed ("original works of authorship") - written works, art, music, architectural drawings, or even programming code for software (most evident nowadays in video game entertainment). With certain exceptions, copyrights allow the owner of the protected materials to control reproduction, performance, new versioning or adaptations, public performance and distribution of the works.



BHARTIYA SKILL DEVELOPMENT UNIVERSITY

Trade Secret: Trade secrets are proprietary procedures, systems, devices, formulas, strategies or other information that is confidential and exclusive to the company using them. They act as competitive advantages for the business.

Question-3 Describe entrepreneurial opportunity recognition & business idea generation approaches.

Entrepreneurship nowadays is one of the fastest developing and expanding fields in the modern economic settings. The term entrepreneurial opportunity recognition, can be used to refer to either the discovery of a clear business idea or the development of an idea into a more feasible business concept over time. Entrepreneurial opportunity recognition is actually a process that's found in the way that individuals and businesses with an entrepreneurial mindset approach new business ventures or ideas. In many ways, it is a constant brainstorming in which individuals look for "new and improved ways" of addressing problems. It could be a brand-new business idea or even new products or services that fulfill customers' needs and expectations.

Most entrepreneurial discoveries are reached after a business opportunity is recognized or an idea is generated. Also, the recognition and generation of business opportunities and ideas creates enabling conditions for the smooth take off and management of business outfits.

On one hand there is an ample example to demonstrate that the majority of entrepreneurial discoveries were reached after planned research and scan of the environment. On the other hand, however, there are findings that this process takes a more spontaneous form most of the time with the actual entrepreneurs simply identifying the opportunity after they have come across revealing information.

Question-4 What is institutional support system? How Rajasthan Government Is fostering start-ups and digital innovation through various institutional support system and govt. programs?

Institutional support refers to the support to the entrepreneurs by different types of institutions. It also refers to formulate policies provide support regulate and facilitate to develop manufacturing and service enterprises with the help of many institutions. Mostly in India this institutional support system has been designed at following levels:

1. Central Government
2. State Government
3. Non-Government Support System

Today, Rajasthan is counted amongst the 'hottest' junctions for entrepreneurs, incubators and even other sectors such as Bollywood, artisans, craftsmen and more. Due to initiatives such as the state's Startup Policy, to E-governance, to several other digitization schemes – the Rajasthan government is currently leading in the charts to emerge as the number two state in the country in ease of doing business index after Uttarakhand. Unveiled in October 2015, the policy has been formed with a focus on areas like social and cleantech – rural infrastructure & services, crafts, water, sanitation, renewable energy and healthcare, including asset-light models of healthcare delivery, and medical devices.

Rajasthan State Industrial Development and Investment Corporation (RIICO), a state government agency, has developed 322 industrial areas in Rajasthan. These industrial areas are provided with water, power, roads, shops and telecommunication facilities. Services provided by RIICO to investors and entrepreneurs include: site selection and acquisition of land, financial assistance to small, medium, and large scale projects, equity participation in large projects on merit, technical consultancy for project identification and tie-up escort services, facilitation of government clearances, merchant banking and financial tie-ups, extending incentives and concessions according to the policy of state government and Department of Industries.



BHARTIYA SKILL DEVELOPMENT UNIVERSITY

Rajasthan Financial Corporation (RFC) is the term lending development financial institution in Rajasthan state in India. It provides finance to small and medium scale enterprises. It was set up by Government of Rajasthan in 1955. The Corporation has 37 branches and 5 sub offices in 33 districts of the State.



School of General Education
Session: 2019-20 (Summer Semester)
B. Voc. Program, 3rd Semester,
End-Sem. Examination

Course Code: GEN 1304

Time: 2 Hours

Course Name: Personality Development

Max. Marks: 50

Instruction: The question paper comprises three sections A, B & C. Attempt all questions.

Marks allotted are mentioned against each section.

Section – A

10X01 = 10 Marks

Q1. Match **T** in the term **SMART Goals** with the correct option:

- (a) Threat
- (b) Time bound
- (c) Total
- (d) Technique

Q2. An individual's self-confidence in himself or herself brings about:

- (a) Happiness
- (b) Motivation
- (c) Better health
- (d) All of the above

Q 3. The triple E's of attitude are environment, education and _____.

- (a) Experience
- (b) Equality
- (c) Equipment
- (d) Elementary

Q4. Solving problems through an indirect and creative approach is called:

- (a) Negative Attitude
- (b) Lateral Thinking
- (c) Goal Setting
- (d) Motivational Theory

Q5. In SWOT Analysis, strengths and weaknesses are:

- (a) External components
- (b) Internal components

Q6. Identify the full form of BCC in an E-mail from the given options:

- (a) Blind Carbon Copy
- (b) Board of Control for Cricket
- (c) British Chambers of Commerce
- (d) None of the above



BHARTIYA SKILL DEVELOPMENT UNIVERSITY

- Q7.** Individuals who pay attention to the good rather than bad in people, situations and events have a:
- (a) Negative attitude
 - (b) Lazy nature
 - (c) Dishonest nature
 - (d) Positive attitude
- Q 8.** Which of the following is a source of stress?
- (a) Environment
 - (b) Society
 - (c) Thoughts
 - (d) All of the above
- Q9.** Studying because you want to get a good grade is an example of:
- (a) Extrinsic motivation
 - (b) Intrinsic motivation
- Q10.** Goals that have an outcome but no fixed time limit are called:
- (a) Flexible goals
 - (b) Fixed goals
 - (c) Short-term goals
 - (d) Long-term goals

Section – B

04X04 = 16 Marks

- Q11.** Write a short note on lateral thinking.
- Q12.** Name any 6 steps one can take to fight stress.
- Q13.** Define goals and name the different kinds of goals?
- Q14.** What is the importance of SWOT Analysis for a student?

Section – C

04X06 = 24 Marks

- Q15.** State the differences between individuals having a positive attitude and attitude.
- Q16.** Explain the word motivation and name the different types of motivation giving an example of each type.
- Q17.** Draw a flow diagram showing the blueprint of your success.
- Q18.** Write an E-mail to the Principal of your School asking for fees concession keeping in mind the etiquette of E-mail writing.

Q12. Name any 6 steps one can take to fight stress.

Ans12. Some steps which can be taken to fight stress are:

1. Practice meditation.
2. Forgive and forget.
3. Have a positive attitude to life.
4. Practice the 4 A's: Accept, Avoid, Alter and Adapt.
5. Keep time aside for fun and relaxation.
6. Eat a healthy diet.
7. Avoid multitasking.

Q13. Define goals and name the different kinds of goals.

Ans13. A goal is an idea of a desired result that a person plans and tries to achieve. It is an end towards which effort is directed. There are four different kinds of goals. They are as follows:

1. Short-Term Goals.
2. Long-Term Goals.
3. Fixed Goals.
4. Flexible Goals.

Q14. What is the importance of SWOT Analysis for a student?

Ans14. SWOT Analysis is important for a student:

1. To gain advantage from your strengths.
2. To overcome your weaknesses.
3. To make full use of the opportunities which come your way.
4. To be prepared to face threats which may come your way.
5. To make better decisions.

Section – C

04X06 = 24 Marks

Q15. State the differences between individuals having a positive attitude and negative attitude.

Ans15. Some differences between individuals having a positive attitude and a negative attitude are as given in the table below:

Positive Attitude	Negative Attitude
Individuals who have a positive attitude will pay attention to the good, rather than bad in people, situations, events, etc.	People with a negative attitude ignore the good and pay attention to the bad in people, situations, events, etc.
Positive attitudes are rewarded. It means the individual is encouraged to do the same thing in the future.	Negative attitudes are punished to discourage the same action in the future.
If we think positive thoughts we will surely experience such emotions as joy, love, gratitude, peace, and hope.	If we think negative thoughts we will have negative feelings such as anger, disappointment, irritation, envy, etc.
Having a “positive attitude” means a person believes everything happens for the best in the end.	A person with a “negatives attitude” tends to believe their best days are in the past. There is nothing to “look forward to” and considers it a waste of time and energy.
It is an optimistic approach for a person to achieve good results.	It is a pessimistic mindset of a person who is not capable of handling critical issues.
It can achieve long-term goals easily and in time	It can achieve some initial goals but not the long-term goals
It is a process of solving problems.	It is a process of looking for problems.
A person with a positive attitude pays attention to the virtues of others.	A person with a negative attitude pays attention to other people’s shortcomings.
These persons always see opportunities.	These persons see only limitations.

Q16. Explain the word motivation and name the different types of motivation giving an example of each type.

Ans16. Motivation is derived from the Latin word “movere” which means “to move” or “to activate”. Motivation is the process of arousing the action, sustaining the activity in process and regulating the pattern of activity. There are 2 types of motivation:

1. Extrinsic Motivation. Extrinsic motivation occurs when we are motivated to perform a behaviour or engage in an activity to earn a reward or to avoid punishment.

Eg. Competing in a contest to win a scholarship. Cleaning up your room to avoid getting a scolding. Studying well to score a good grade.

2. Intrinsic Motivation. Intrinsic motivation occurs when we are motivated by an internal desire to perform an activity for its own sake rather than the desire for some external reward.

Eg. Participating in a sport because you find the activity enjoyable. Solving a word puzzle because you find it fun and exciting. Playing a video game because you find it exciting.

Q17. Draw a flow diagram showing your blueprint of success.

Ans17. The students will draw their individual flow diagrams showing the blueprint of their success.

Q18. Write an E-mail to the Principal of your School asking for fees concession keeping in mind the etiquette of E-mail writing.

Ans18. Students will write individual answers keeping in mind to include the following:

- Proper subject line
- Greeting
- Introduction
- Request
- Closing remark/Thank you
- Signature

11

()

()



B

School of General Education
Session: 2019-20 (Summer Semester)
B. Voc. Program, Third Semester,
End-Sem. Examination

Course Code: GEN 1305

Time: 2 Hours

Course Name: Elementary Drawing

Max. Marks: 50

Instruction:

1. Answer all questions from section – A, each question carries one mark.
2. Answer all questions from section – B, each question carries Four marks.
3. Answer all questions from section – C, each question carries Six marks.

Section – A

10X01 = 10 Marks

1. Short-break lines are drawn freehand while long-break lines are ruled lines.
A. True
B. False
2. In Engineering Drawing, Is Protector used to draw parallel lines?
a. Yes
b. No
3. In HB Pencil B stands for?
a. Blackness
b. Boldness
c. Baldness
d. Brittle
4. The Sizes of drawing sheet from A₀ to A₅ increases.
a. True
b. false
5. What are the dimensions of a A4 sheet?
a. 210X297
b. 210X296
c. 210X205
d. 205X310



BHARTIYA SKILL DEVELOPMENT UNIVERSITY

Section – C

04X06 = 24 Marks

5. Draw 6(Six) alphabets F to K in the Drawing sheet.
6. A shaft having diameter of $(30+0.05)$ mm. There are three conditions for accessing/inspection the actual dimension as pass, rework and rejected. Satisfy all the three conditions with mentioned dimension.
7. Define the term "fits". Explain the types of fits.
8. Draw front view, top view and side of the given object.

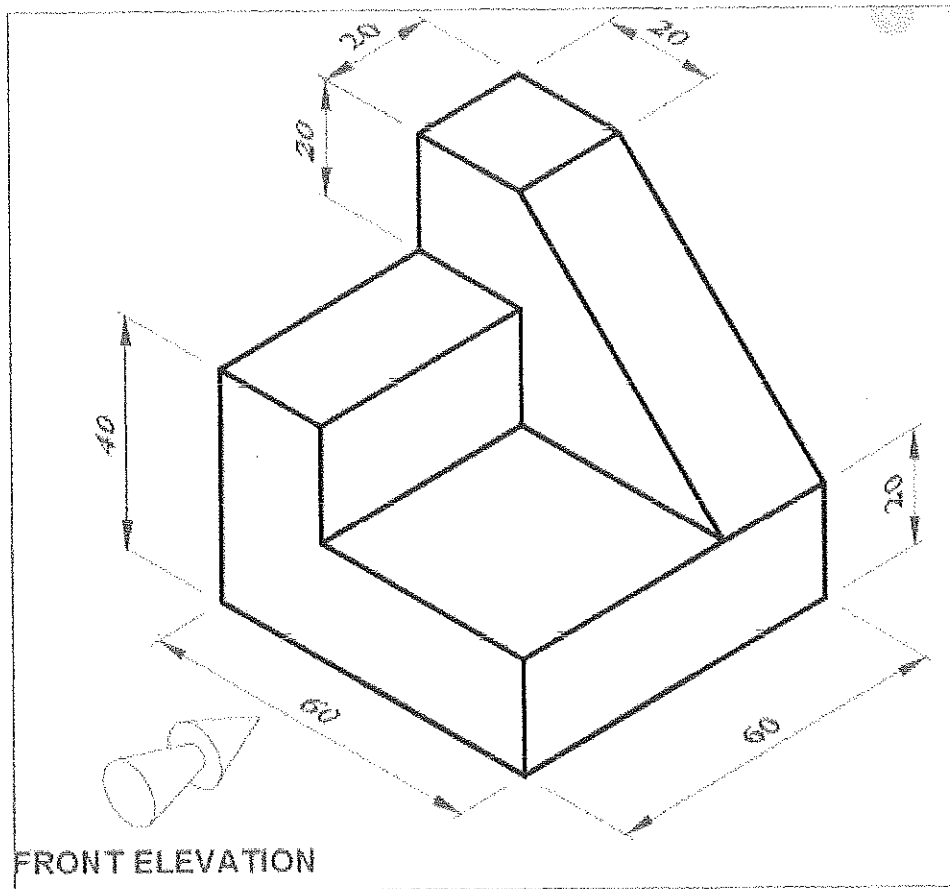

Handwritten signature

()

()



School of General Education
Session: 2019-20 (Summer)
B. Voc. Program, 3rd-Semester,
End-Sem. Examination

Course Code: GEN 1306
Course Name: Business & Management Skills

Max. Marks: 50
Time: 2 Hours

Instruction: Attempt all questions. Write answers legibly in English only.

Section – A

10X01 = 10 Marks

- Q1.** The term Skills refer to....
- (a) The ability to apply knowledge to specific situations
 - (b) The ability developed through exposure and experience
 - (c) The ability of sensory input and output.
 - (d) All of the above
- Q2.** Which one of the following is a dimension of communication skills?
- (a) PPT Presentation Skills
 - (b) Oral Presentation Skills
 - (c) Public Speaking Skills
 - (d) Spoken skills
- Q3.** Bureaucratic leadership style refers to:
- (a) Encouraging the team members to play an important role in decision-making process
 - (b) Strictly adhering to the organizational rules and policies
 - (c) Trusting their employees/team to perform the job themselves
 - (d) All of the above
- Q4.** Some of the skills related to team building are:
- (a) Positive & Negative Reinforcement
 - (b) Ability to Identifying the Strengths and Weaknesses of Team Members
 - (c) Ability to Creating Milestones, Coordinating & Evaluating
 - (d) All of the above
- Q5.** One of the management skills explained by Professor Robert Katz is....
- (a) Communication Skills
 - (b) Strategic Thinking Skills
 - (c) Conceptual Skills
 - (d) All of the above
- Q6.** The 'D' in the 4D Model of Leadership Effectiveness refers to....
- (a) Discover
 - (b) Develop
 - (c) Distinguish
 - (d) All of the above



BHARTIYA SKILL DEVELOPMENT UNIVERSITY

The Management Skills significantly contributes to...

- (a) Enhance execution of business strategy by developing skills that support business objectives.
- (b) Improve competitiveness by producing superior products and services
- (c) Reduce costs by identifying true training needs that eliminates wasteful spending
- (d) All of the above

Q8. Thinking skills are the....

- (a) Mental activities you use to process information
- (b) Mental activities you use to make connections
- (c) Mental activities you use to make decisions, and create new ideas
- (d) All of the above

Q9. One of the elements of SWOT analysis is....

- (a) Environmental Opportunities
- (b) Organizational Opportunities
- (c) Broader opportunities and threats (O-T)
- (d) All of the above

Q10. One of the perspectives related to Johari window is.....

- (a) Open self
- (b) Blind self
- (c) Hidden self
- (d) All of the above

Section – B

04X04 = 16 Marks

- Q11. Discuss in your own words the importance of Johari window model.
- Q12. What do you mean by Delegation and Supervision?
- Q13. What are essential skills of public speaking?
- Q14. Describe briefly the different approaches to team building.

Section – C

04X06 = 24 Marks

- Q15. Distinguish between the creative thinking and Design thinking.
- Q16. Discuss briefly the Mintzberg's model of managerial roles and skills.
- Q17. Describe the key action-skills required for proper exercise of Directing function of Management.
- Q18. Discuss the steps involved in the preparation of a Presentation.



BHARTIYA SKILL DEVELOPMENT UNIVERSITY

Registration No.:

School of Entrepreneurship Skills
Session: 2019-20 (Summer)
B. Voc. Program, 3rd-Semester,
End-Sem. Examination
SET B

Course Name: Business & Management Skills (SES1306)

ANSWER KEYS

Section – A

10X01 = 10 Marks

Note: 10 objective type questions, each question carries 01 mark.

- Q1. The ability to apply knowledge to specific situations
- Q2. Spoken skills
- Q3. Strictly adhering to the organizational rules and policies
- Q4. All of the above
- Q5. Conceptual Skills
- Q6. All of the above
- Q7. All of the above
- Q8. All of the above
- Q9. Broader opportunities and threats (O-T).
- Q10. All of the above

Section – B

04X04 = 16 Marks

Note: 04 short answer type questions, each question carries 04 marks.

Question-1 Discuss in your own words the importance of Johari window model.

Answer- Johari Window is a technique for improving self-awareness within an individual. It helps in understanding your relationship with yourself and others. It is a simple and useful tool for illustrating and improving self-awareness, and mutual understanding between individuals within a group. The four Johari Window perspectives are called 'regions' or 'areas' or 'quadrants'. Each of these regions contains and represents the information - feelings, motivation, etc. - known about the person, in terms of whether the information is known or unknown by the person, and whether the information is known or unknown by others in the group.

The four regions, (areas, quadrants, or perspectives) are as follows, showing the quadrant numbers and commonly used names:

- what is known by the person about him/herself and is also known by others - open area, open self, free area, free self, or 'the arena'
- what is unknown by the person about him/herself but which others know - blind area, blind self, or 'blindspot'
- what the person knows about him/herself that others do not know - hidden area, hidden self, avoided area, avoided self or 'facade'
- what is unknown by the person about him/herself and is also unknown by others - unknown area or unknown self

Importance of Johari window model:

This help people improving self-awareness

This helps in understanding one's relationship with self and others.

This plays important role in improving communication skills

This is an important method used for self-discovery.

Question-2 What do you mean by Delegation and Supervision?

Answer- Delegation- Delegation involves assigning responsibility to other people for the completion of work. Communication Skills-to communicate well, to be clear about your expectations and to be sensitive when dealing with problems. The key is to know how to effectively communicate your vision with passion and conviction.

Delegating involves passing on the responsibility for completing a task or controlling a process in your business. You may find it difficult if you are used to completing most tasks yourself.

Effective delegation, however, makes good business sense because it:

- Frees you up for forward and innovative business thinking
- Ensures your team's potential is maximized



Supervision: Supervision implies overseeing the work of subordinates by their superiors. It is the act of watching & directing work & workers. Supervision, as an element of directing:

- Process of guiding the efforts of employees and other resources to accomplish desired objectives.
- Overseeing people at work
- Involves instructing, observing, monitoring and guiding employees.
- Carried out at all levels but more important at the lower levels therefore the term 'Supervisor' is used at the operative's level of management

Question-3 What are Essential Public speaking skills?

Answer- Public speaking skills are valuable both in your personal life and in your career. Even if you don't regularly engage in public speaking, developing skills in this area will increase your confidence and reduce anxiety about situations in which you may be called upon to speak in public.

Essential Public speaking skills

Clear Articulation: Of course, public speakers must be able to speak well. Enunciate clearly, speak loudly enough, and use good grammar

Engaging Presentation Style: Presentation style includes vocal tone, body language, facial expression, and timing.

Assessing the Needs of the Audience: Some audiences want a lot of technical detail; others don't. Some enjoy humor; others won't. There are jokes that work in some crowds but not others. To draft a successful talk and to adopt the appropriate presentation style, you need to be able to assess the needs of your audience.

PowerPoint Skills: PowerPoint is a popular software used for creating slides. Not all public speakers use slides, but slides are so common that doing without them is sometimes called "speaking naked."

Composition Skills: Whether you write your talk up ahead of time or work extemporaneously, you must be able to construct talks that are rational, coherent, easy to understand and cover all the points you want to hit.

Question-4 Describe briefly the different approaches to team building.

Answer- What is a Team: A group of people with different skills and different tasks, who work together on a common project, service, or goal, to achieve their goals.

Team building is a collective term for various types of activities used to enhance social relations and define roles within teams, often involving collaborative tasks. Team building is one of the most widely used group-development activities in organizations. This includes:

- Aligning around goals
- Building effective working relationships
- Reducing team members' role ambiguity
- Finding solutions to team problems

Different approaches to team building:

Setting Goals: This emphasizes the importance of clear objectives and individual and team goals. Team members become involved in action planning to identify ways to define success and failure and achieve goals.

Role clarification: This emphasizes improving team members' understanding of their own and others' respective roles and duties. It emphasizes the members' interdependence and the value of having each member focus on their own role in the team's success.

Problem solving: This emphasizes identifying major problems within the team and working together to find solutions. This can have the added benefit of enhancing critical-thinking.

Interpersonal-relations: This emphasizes increasing teamwork skills such as giving and receiving support, communication and sharing. Teams with fewer interpersonal conflicts generally function more effectively than others. A facilitator guides the conversations to develop mutual trust and open communication between team members.



Note: 04 long type questions, each question carries 06 marks.

Question-1 Distinguish between the creative thinking and Design thinking.

Answer- Thinking refers to the process of creating a logical series of connective facets between items of information. Most of the time, thinking just happens automatically but we can also make efforts to consciously think to solve a problem or decision making.

Thinking enables you to connect and integrate new experiences into your existing understanding and perception of how things are.

Creative thinking: Creative thinking means looking at something in a new way. It is a way of looking at problems or situations from a fresh perspective that suggests unorthodox solutions (which may look unsettling at first). Creative Thinking refers to the generation of new ideas breaking from established thoughts, theories, rules, and procedures. Creative thinking refers to the ability to conceive new and innovative ideas by breaking from established thoughts, theories, rules, and procedures. It involves putting things together in new and imaginative ways. Creative thinking is often referred to as "thinking outside the box."

Creative thinking can be stimulated both by an unstructured process such as brainstorming, and by a structured process such as Lateral thinking.

Design thinking: Design thinking is a non-linear, iterative process which seeks to understand users, challenge assumptions, redefine problems and create innovative solutions to prototype and test.

The method consists of 5 phases—

- Empathize,
- Define,
- Ideate,
- Prototype and
- Test

Design thinking is most useful when you want to tackle problems that are ill-defined or unknown.

Question-2 Discuss briefly the Mintzberg's model of managerial roles and skills.

Answer- Management expert and professor Henry Mintzberg recognized that a person as a manager or a Team leader constantly switching roles as tasks, situations, and expectations change. Based on this insight, he developed Mintzberg's 10 Management Roles model that can be used to categorize a manager's different functions.

The ten roles are:

1. Figurehead.
2. Leader.
3. Liaison.
4. Monitor.
5. Disseminator.
6. Spokesperson.
7. Entrepreneur.
8. Disturbance Handler.
9. Resource Allocator.
10. Negotiator.

Let's look at each of the ten managerial roles in greater detail-

Interpersonal Category: The managerial roles in this category involve providing information and ideas.

1. Figurehead – As a manager, you have social, ceremonial and legal responsibilities. You're expected to be a source of inspiration. People look up to you as a person with authority, and as a figurehead.
2. Leader – This is where you provide leadership for your team, your department or perhaps your entire organization; and it's where you manage the performance and responsibilities of everyone in the group.



BHARTIYA SKILL DEVELOPMENT UNIVERSITY

Liaison – Managers must communicate with internal and external contacts. You need to be able to network effectively on behalf of your organization.

Informational Category: The managerial roles in this category involve processing information.

4. Monitor – In this role, you regularly seek out information related to your organization and industry, looking for relevant changes in the environment. You also monitor your team, in terms of both their productivity, and their well-being.
5. Disseminator – This is where you communicate potentially useful information to your colleagues and your team.
6. Spokesperson – Managers represent and speak for their organization. In this role, you're responsible for transmitting information about your organization and its goals to the people outside it.

Decisional Category: The managerial roles in this category involve using information.

7. Entrepreneur – As a manager, you create and control change within the organization. This means solving problems, generating new ideas, and implementing them.
8. Disturbance Handler – When an organization or team hits an unexpected roadblock, it's the manager who must take charge. You also need to help mediate disputes within it.
9. Resource Allocator – You'll also need to determine where organizational resources are best applied. This involves allocating funding, as well as assigning staff and other organizational resources.
10. Negotiator – You may be needed to take part in, and direct, important negotiations within your team, department, or organization.

Question-3 Describe the key action-skills required for proper exercise of Directing function of Management.

Answer- Directing means giving instructions, guiding, counseling, motivating and leading the staff in an organization in doing work to achieve Organizational goals. Directing is a key managerial function to be performed by the manager along with planning, organizing, staffing and controlling. From top executive to supervisor performs the function of directing and it takes place accordingly wherever superior – subordinate relations exist. Directing is a continuous process initiated at top level and flows to the bottom through organizational hierarchy.

Direction has got following characteristics:

1. Pervasive Function- Directing is required at all levels of organization. Every manager provides guidance and inspiration to his subordinates.
2. Continuous Activity- Direction is a continuous activity as it continuous throughout the life of organization.
3. Human Factor- Directing function is related to subordinates and therefore it is related to human factor. Since human factor is complex and behavior is unpredictable, direction function becomes important.
4. Creative Activity- Direction function helps in converting plans into performance. Without this function, people become inactive and physical resources are meaningless.
5. Executive Function- Direction function is carried out by all managers and executives at all levels throughout the working of an enterprise, a subordinate receives instructions from his superior only.
6. Delegate Function- Direction is supposed to be a function dealing with human beings. Human behavior is unpredictable by nature and conditioning the people's behavior towards the goals of the enterprise is what the executive does in this function. Therefore, it is termed as having delicacy in it to tackle human behavior.

Key Action-Skills required for proper exercise of Directing function of Management involve:

- Involving them in decision-making
- Providing personal encouragement
- Recognizing and rewarding good performance
- Helping to build their confidence to use their own initiative



- Inspiring them with a vision for success
- Ensuring good two-way communication

Question-4 Discuss the steps involved in the preparation of a Presentation.

Answer- A presentation is the process of presenting a topic to an audience. It is typically a demonstration, introduction, lecture, or speech meant to inform, persuade, inspire, motivate, or to build good will or to present a new idea or product. The term can also be used for a formal or ritualized introduction or offering, as with the presentation of a debutante. Presentations in certain formats are also known as keynote address.

Following are the Steps in Preparing a Presentation-

Planning Your Presentation

Step 1: Analyze your audience

Step 2: Select a topic

Step 3: Define the objective of the presentation

Preparing the Content of Your Presentation

Step 4: Prepare the body of the presentation

Step 5: Prepare the introduction and conclusion

Practicing and Delivering

Step 6: Practice delivering the presentation

