

**BHARTIYA SKILL DEVELOPMENT UNIVERSITY****School of Carpenter Skills****1<sup>st</sup> Semester, 1<sup>st</sup> In-Sem. Examination****B. Voc. Program, Summer Semester (2018-19)****Course Code: SCS1101****Time: 1 Hour****Course Name: Hand skills & Transfer of Measurement****Max. Marks: 20****Instructions:**

1. Answer all questions from section A, each question carries one mark.
2. Answer all question from section B, each question carries two marks.
3. Answer all question from section C, each question carries three marks.

**Section – A**

05X01 = 05 Marks

Q.1. Which one of the following is used to sharp chisel?

- (a) Flat file (b) Sharpening stone  
(c) Both of these (d) None of these

Q.2 Which one of the following is use of marking gauge?

- (a) Mark dimension (b) Check 90°  
(c) Both of these (d) None of these

Q.3. Which one of the following is used to check 90°?

- (a) Marking gauge (b) Try square  
(c) Chisel (d) Hammer

Q.4. Which one of the following is used to transfer angle from one piece to another?

- (a) Try square (b) Marking gauge  
(c) Double meter (d) Sliding bevel

Q.5. Which one of the following pencil is used for light measurement during transferring measurement on work piece?

- (a) 0.7 mm (b) 0.2 mm  
(c) 0.1 mm (d) HB

**Section – B**

03X02 = 06 Marks

Q.6. Explain the significance of triangle sign with an example.

Q.7. Explain Face marking signs in detail.

Q.8. List hand tools used in carpentry.

**Section – C**

03X03 = 09 Marks

Q. 9. Explain Marking Gauge with a suitable diagram

Q.10. Prepare a work plan and tool list for Dovetail joint

Q.11. Explain the parts of jack planer with a suitable diagram.

7

10

( )

1. The first part of the document discusses the importance of maintaining accurate records of all transactions. This is essential for ensuring the integrity of the financial statements and for providing a clear audit trail.

2. The second part of the document outlines the various methods used to collect and analyze data. These methods include interviews, surveys, and focus groups, each of which has its own strengths and limitations.

( )

3. The third part of the document provides a detailed overview of the data analysis process. This includes a discussion of the various statistical techniques used to interpret the data and to identify trends and patterns. The final part of the document concludes with a summary of the findings and a discussion of the implications for future research.

**BHARTIYA SKILL DEVELOPMENT UNIVERSITY****School of Carpenter Skills****1<sup>st</sup> Semester, 1<sup>st</sup>In-Sem. Examination****B. Voc. Program, Summer Semester (2018-19)****Course Code: SCS1101****Time: 1 Hour****Course Name: Hand skills & Transfer of Measurement****Max. Marks: 20****Instructions:**

1. Answer all questions from section A, each question carries one mark.
2. Answer all question from section B, each question carries two marks.
3. Answer all question from section C, each question carries three marks.

**Section – A**

05X01 = 05 Marks

Q.1. Which one of the following is used to sharp chisel?

- (a) Flat file (b) Sharpening stone  
(c) Both of these (d) None of these (b)

Q.2 Which one of the following is use of marking gauge?

- (a) Mark dimension (b) Check 90°  
(c) Both of these (d) None of these (a)

Q.3. Which one of the following is used to check 90°?

- (a) Marking gauge (b) Try square  
(c) Chisel (d) Hammer (b)

Q.4. Which one of the following is used to transfer angle from one piece to another?

- (a) Try square (b) Marking gauge  
(c) Double meter (d) Sliding bevel (d)

Q.5. Which one of the following pencil is used for light measurement during transferring measurement on work piece?

- (a) 0.7 mm (b) 0.2 mm  
(c) 0.1 mm (d) HB (b)

**Section – B**

03X02 = 06 Marks

Q.6. Explain the significance of triangle sign with an example.

**Ans.** - Tringle sign is used for assembly purpose. We used this sign as an identification of the part. This tringle making process follows some following points:

1. We always make tringle according to front view of the drawing.
2. If it is not possible to make tringle sign on all parts in front view than only we go for top or side view.
3. This is not necessary to complete the tringle sign always. (in case of less no. of component)

## BHARTIYA SKILL DEVELOPMENT UNIVERSITY

4. Triangle sign should always come on the corners of work piece.

EXAMPLE:

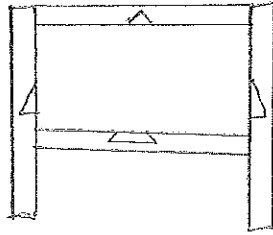

Q.7. Explain Face marking signs in detail.

**Ans.- 1. Cross** - This sign is used from where material has to be cut and will go through out. These marks will stay on width side during face marking.



**2. Cross with depth** - This mark is used where we need to take out material to the certain given depth.



**3. Snack line** - These lines are used from where material has to be taken out only.



**4. Triangle sign** - This sign is used to mark triangle which is helpful in assembly.



Q.8. List hand tools used in carpentry.

**Ans.-**

- |                  |                             |
|------------------|-----------------------------|
| 1. Folding ruler | 0 - 2 Meter                 |
| 2. Steel ruler   | 0 - 150 mm                  |
| 3. Roll Meter    | 0 - 3 Meter                 |
| 4. Try square    |                             |
| 5. Marking gauge |                             |
| 6. Hammer        | Nylon, Iron                 |
| 7. Clamps        |                             |
| 8. Chisel        | 8mm, 12mm, 16mm, 26mm, 32mm |
| 9. Hand saw      |                             |
| 10. Sanding Cork |                             |
| 11. Jack planer  |                             |

# BHARTIYA SKILL DEVELOPMENT UNIVERSITY

## Section – C

03X03 = 09 Marks

Q. 9. Explain Marking Gauge with a suitable diagram

**Ans.** - A marking gauge, also known as a scratch gauge, it is used in woodworking and metalworking to mark out lines for cutting or other operations. The purpose of the gauge is to scribe a line parallel to a reference edge or surface. It is used in joinery and sheet metal operations.

The gauge consists of a beam, a headstock, and a scribing or marking implement, typically a pin, knife, pen or wheel. The headstock slides along the beam, and is locked in place by various means: a locking screw, cam lever, or a wedge. The marking implement is fixed to one end of the beam.

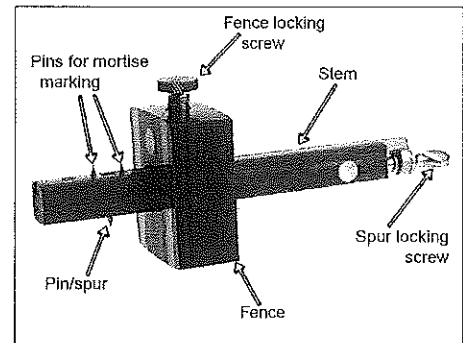

Q.10. Prepare a work plan and tool list for Dovetail joint.

**Ans.** – Work plan

1. Drawing reading.
2. Material verification.
3. Part identification Triangle sign.
4. Measurement transfer.
5. Sawing operation.
6. Chiseling operation.
7. Measurement transfer to another work piece.
8. Sawing operation.
9. Chiseling operation.
10. Inspection report.
11. Check work piece quality.

Tool List: -

- |                  |             |
|------------------|-------------|
| 1. Folding ruler | 0 - 2 Meter |
| 2. Steel ruler   | 0 – 150 mm  |
| 3. Roll Meter    | 0 – 3 Meter |
| 4. Try square    |             |
| 5. Marking gauge |             |
| 6. Hammer        | Nylon       |
| 7. Clamps        | 2×          |
| 8. Chisel        | 12mm, 26mm  |
| 9. Hand saw      |             |

## BHARTIYA SKILL DEVELOPMENT UNIVERSITY

Q.11. Explain the parts of jack planer with a suitable diagram.

Ans.

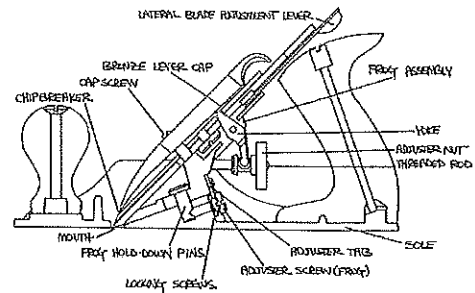
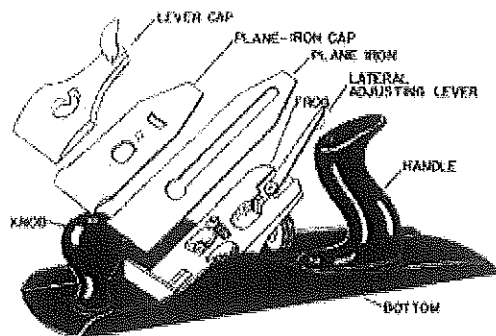

1. Leaver cap: - Leaver cap is used to hold all the assembly of iron cap and cutting blade.
2. Wedge: - Wedge is mainly responsible for the chip breaking while cutting.
3. Blade: - Blade is mounted in between planer and the cap is used to cut the material and this blade is adjustable in depth.
4. Knob: - Knob is mounted in front of the planer it is mainly used to hold the planer properly.
5. Handle: - Handle is mounted at the end of this planer this is to push and pull planer and also to hold it properly.
6. Adjustable lever: - This lever is used adjust blade tilting.
7. Bottom: - This is made of cast iron and used to provide perfect holding on surface.

**BHARTIYA SKILL DEVELOPMENT UNIVERSITY****School of Carpenter Skills**1<sup>st</sup> Semester, 1<sup>st</sup>In-Sem. Examination

B. Voc. Program, Summer Semester (2018-19)

Course Code: SCS1102

Time: 1 Hour

Course Name: Handy Machine

Max. Marks: 20

**Instructions:**

1. Answer all questions from section A, each question carries one mark.
2. Answer all question from section B, each question carries two marks.
3. Answer all question from section C, each question carries three marks.

**Section – A**

05X01 = 05 Marks

Q.1. Which one of the following is Maximum depth of circular saw without a track?

- (a) 65 mm (b) 55 mm  
(c) 50 mm (d) 45 mm

Q.2 Which one of the following is sanding stroke of hand sander ETS EC 150/5 EQ?

- (a) 3 mm (b) 6 mm  
(c) 150 mm (d) 5 mm

Q.3. Which one of the following is Maximum depth of circular saw with a track?

- (a) 65 mm (b) 55 mm  
(c) 50 mm (d) 45 mm

Q.4. Which one of the following is diameter of sanding pad of hand sander ETS EC 150/5 EQ?

- (a) 160 mm (b) 150 mm  
(c) 120 mm (d) 5 mm

Q.5. Which one of the following is maximum angle in circular saw?

- (a) 45° (b) 43°  
(c) 47° (d) 41°

**Section – B**

03X02 = 06 Marks

Q.6. Explain how to change blade in circular saw.

Q.7. There is a task to make 12 mm groove in panel of 25 mm by using circular saw with guide rail so explain what should be the depth setting in machine to make that groove?

Q.8. Write down technical data of FESTOOL dust collector.



## BHARTIYA SKILL DEVELOPMENT UNIVERSITY

### Section – C

03X03 = 09 Marks

Q. 9. Describe general safety precaution while using handy machines.

Q.10. Suppose that you are working with circular saw which is connected with dust collector how will you find that bag of dust collector is full and after realizing that bag is full how will you immediate react to it?

Q.11. Explain technical data and application of hand sander.

**BHARTIYA SKILL DEVELOPMENT UNIVERSITY****School of Carpenter Skills****1<sup>st</sup> Semester, 1<sup>st</sup> In-Sem. Examination****B. Voc. Program, Summer Semester (2018-19)****Course Code: SCS1102****Time: 1 Hour****Course Name: Handy Machine****Max. Marks: 20****Instructions:**

1. Answer all questions from section A, each question carries one mark.
2. Answer all question from section B, each question carries two marks.
3. Answer all question from section C, each question carries three marks.

**Section – A**

05X01 = 05 Marks

Q.1. Which one of the following is Maximum depth of circular saw without a track?

- (a) 65 mm (b) 55 mm  
(c) 50 mm (d) 45 mm (b)

Q.2 Which one of the following is sanding stroke of hand sander ETS EC 150/5 EQ?

- (a) 3 mm (b) 6 mm  
(c) 150 mm (d) 5 mm (d)

Q.3. Which one of the following is Maximum depth of circular saw with a track?

- (a) 65 mm (b) 55 mm  
(c) 50 mm (d) 45 mm (c)

Q.4. Which one of the following is diameter of sanding pad of hand sander ETS EC 150/5 EQ?

- (a) 160 mm (b) 150 mm  
(c) 120 mm (d) 5 mm (b)

Q.5. Which one of the following is maximum angle in circular saw?

- (a) 45° (b) 43°  
(c) 47° (d) 41° (c)

**Section – B**

03X02 = 06 Marks

Q.6. Explain how to change blade in circular saw.

**Ans.** Steps to change blade of circular saw

1. Take out the Allen key which is placed at the top of the circular saw.
2. Tilt up the fast fix from its position and take the saw blade below from its zero position.
3. Rotate the nut and loosen it.
4. Carefully take out the blade from its position.
5. Put the new saw blade according to the work piece.

**BHARTIYA SKILL DEVELOPMENT UNIVERSITY**

6. Tight it with the help of Allen key

Q.7. There is a task to make 12 mm groove in panel of 25 mm by using circular saw with guide rail so explain what should be the depth setting in machine to make that groove?

**Ans.-**

1. To make that groove first we need to transfer measurement
2. Set track on the mark with the help of track clamps so it will not move while cutting.
3. Set depth 12 mm in FS scale.
4. Now start cutting groove.

Q.8. Write down technical data of FESTOOL dust collector.

**Ans. CTL 26 E**

CTL = Model number

Tank capacity = 26 liter

Suction capacity = 26 liter

Suction power = 10 – 0.7 Mpa

**Section – C**

03X03 = 09 Marks

Q. 9. Describe general safety precaution while using handy machines.

**Ans. –**

**1 WORK AREA SAFETY**

- a) Keep work area clean and well lit.
- b) Do not operate power tools in explosive atmospheres, such as in the presence of flammable liquids, gases or dust. Power tools create sparks which may ignite the dust or fumes.
- c) Keep children and bystanders away while operating a power tool.
- d) Never leave the electric power tool unattended.

**2 ELECTRICAL SAFETY**

- a) Power tool plugs must match the outlet. Never modify the plug in any way. Do not use any adapter plugs with earthed (grounded) power tools.
- b) Avoid body contact with earthed or grounded surfaces, such as pipes, radiators, ranges and refrigerators. There is an increased risk of electric shock if your body is earthed or grounded.
- c) Do not expose power tools to rain or wet conditions. Water entering a power tool will increase the risk of electric shock.

**3 PERSONAL SAFETY**

- a) Stay alert, watch what you are doing and use common sense when operating a power tool. Do not use a power tool while you are tired or under the influence of drugs, alcohol or medication. A moment of inattention while operating power tools may result in serious personal injury.

## BHARTIYA SKILL DEVELOPMENT UNIVERSITY

- b) Use personal protective equipment. Always wear eye protection. Protective equipment such as dust mask, non-skid safety shoes, hard hat, or hearing protection used for appropriate conditions will reduce personal injuries.
- c) Prevent unintentional starting. Ensure the switch is in the off-position before connecting to power source and/or battery pack, picking up or carrying the tool. Carrying power tools with your finger on the switch or energizing power tools that have the switch on invites accidents.
- d) Remove any adjusting key or wrench before turning the power tool on. A wrench or a key left attached to a rotating part of the power tool may result in personal injury.
- e) Do not overreach.

Q.10. Suppose that you are working with circular saw which is connected with dust collector how will you find that bag of dust collector is full and after realizing that bag is full how will you immediately react to it?

Q.11. Explain technical data and application of hand sander.

**Ans.-**

**Technical data: -**

1. Interchangeable sanding pad diameter = 150 MM
2. Eccentric motion speed = 6000- 10000 min<sup>-1</sup>
3. Sanding stroke = 5 MM
4. Power consumption = 400 W
5. Weight = 1.20 Kg
6. Dust extraction connection diameter = 27 MM

**Application: -**

1. Intermediate and coarse sanding of clear coats and fillers.
2. For flat and curved surface.
3. For final sanding of fillers.



**BHARTIYA SKILL DEVELOPMENT UNIVERSITY****School of Carpenter Skills****1<sup>st</sup> Semester, 1<sup>st</sup>In-Sem. Examination****B. Voc. Program, Summer Semester (2018-19)****Course Code: SCS1105****Time: 1 Hour****Course Name: Carpenter Materials****Max. Marks: 20****Instructions:**

1. Answer all questions from section A, each question carries one mark.
2. Answer all question from section B, each question carries two marks.
3. Answer all question from section C, each question carries three marks.

**Section – A**

05X01 = 05 Marks

Q.1. Which one of the following is an example of soft wood?

- (a) Cherry (b) Teak  
(c) Pine (d) Oak

Q.2. Which one of the following is a natural defect in wood?

- (a) Case hardening (b) Twisted fibers  
(c) Dry rot (d) Wet rot

Q.3. Which one of the following is not a defect due to natural forces in wood?

- (a) Rind Galls (b) Knot  
(c) Chemical strain (d) Shakes

Q.4. Which one of the following is a defect due to conversion?

- (a) Torn Grain (b) Twisted fibers  
(c) Brown rot (d) Dry rot

Q.5. Which one of the following is a defect due to seasoning?

- (a) Brown rot (b) Twist  
(c) Heart rot (d) Knot

**Section – B**

03X02 = 06 Marks

Q.6. Discuss four types of natural defects in wood.

Q.7. Discuss seasoning defects with suitable diagrams.

Q.8. Explain qualities of a good timber.

**Section – C**

03X03 = 09 Marks

Q. 9. Differentiate between Hard wood and Soft wood.

Q.10. Explain the structure of wood growth with the help of a diagram. Explain the formation of annual ring.

Q.11. What do you mean by seasoning process, explain its various types?



**BHARTIYA SKILL DEVELOPMENT UNIVERSITY****School of Carpenter Skills****1<sup>st</sup> Semester, 1<sup>st</sup>In-Sem. Examination****B. Voc. Program, Summer Semester (2018-19)****Course Code: SCS1105****Time: 1 Hour****Course Name: Carpenter Materials****Max. Marks: 20****Instructions:**

1. Answer all questions from section A, each question carries one mark.
2. Answer all question from section B, each question carries two marks.
3. Answer all question from section C, each question carries three marks.

**Section – A**

05X01 = 05 Marks

Q.1. Which one of the following is soft wood?

- |            |          |     |
|------------|----------|-----|
| (a) Cherry | (b) Teak |     |
| (c) Pine   | (d) Oak  | (a) |

Q.2. Which one of the following is natural defect in wood?

- |                    |                    |     |
|--------------------|--------------------|-----|
| (a) Case hardening | (b) Twisted fibers |     |
| (c) Dry rot        | (d) Wet rot        | (b) |

Q.3. Which one of the following formed when Branch has come out of the tree?

- |               |               |     |
|---------------|---------------|-----|
| (a) Wet rot   | (b) Heart rot |     |
| (c) Brown rot | (d) White rot | (b) |

Q.4. Which one of the following is defect due to conversion in wood?

- |                |                    |     |
|----------------|--------------------|-----|
| (a) Torn Grain | (b) Twisted fibers |     |
| (c) Brown rot  | (d) Dry rot        | (a) |

Q.5. Which one of the following is defect due to seasoning in wood?

- |               |           |     |
|---------------|-----------|-----|
| (a) Brown rot | (b) Twist |     |
| (c) Heart rot | (d) Knot  | (b) |

**Section – B**

03X02 = 06 Marks

Q.6. Discuss four types of natural defect in wood.

**Ans. 1. Knots:** -these are the bases of branches or limbs which are broken or cut off from the tree. The portion from which the branch is removed receives nourishment from the stem for a pretty long time and it ultimately results in formation of dark hard rings which are known as knots.

**2. Shakes:** -these are longitudinal separations in wood between the annual rings. These are cracks which partly or completely separate fibers of wood. The separations make the wood undesirable when Appearance is important.

**3. Chemical stain:** -the wood is sometimes discolored by the chemical action caused with it by some external agency. This is known as chemical stain.

## BHARTIYA SKILL DEVELOPMENT UNIVERSITY

**4. Rind galls:** -the rind means bark and gall indicates abnormal growth. Hence peculiar curved swelling found on the body of tree are known as rind gall. They develop at points from where branches are improperly cut off or removed. They are rarely found in a tree

Q.7. Discuss seasoning defects with suitable diagram.

**Ans. 1. Bow:** -this defect is indicated by curvature formed in direction of length of timber.

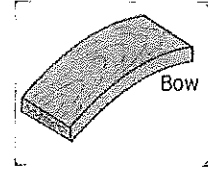

**2. Cup:** -this defect is indicated by curvature formed in transverse direction of timber



**3. check:** -a crack which separates fibers of wood. it does not extend from one end to the other.

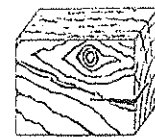

**4. Split:** -when the extends from one end to other, it is known as a split.

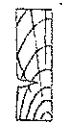

**5. Twist:** - when a piece of timber has spirally distorted along its length, it is known as a twist.

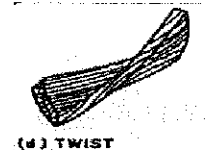

**6. Honey-combing:** - due to stress developed during drying, various radial and circular cracks develop in the interior portion of timber

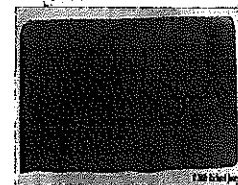

Q.8. Explain quality of good timber.

**Ans. 1.** It Should have Straight Fiber

2. Wood Obtained from near the pith is always better than the rest of the tree.

3. It should be free from knots.

4. It should not possess natural defects.

5. On sawing it should give a sweet smell.

6. It should have regular annual rings.

7. It should not clot the saw teeth during sawing.

8. It should be Strong and heavy.

9. It should not split when nails are driven in to it.

10. It should bear high resistance shock and stresses.

11. It should have dark colour, give clear sound, easily workable, high resistance to fire and free from decay.

12. On planning it should give silky texture and bright appearance.

13. It should not warp or twist after seasoning.

# BHARTIYA SKILL DEVELOPMENT UNIVERSITY

## Section – C

03X03 = 09 Marks

Q. 9. Differentiate between hard wood and soft wood.

**Ans.**

Soft wood	Hard wood
It is resinous wood having a fragrant smell and regular texture.	It is non-resinous wood containing fairly good amount of acid.
Straight fiber and good texture.	Fibers are quite close and compact.
Light in color and weight.	Dark in color and heavy in weight
annual rings are distinct	Annual rings are not distinct
Good tensile strength and week shear strength	Good tensile as well as shear strength
Get split quickly	Does not split quickly
Weaker and less durable	stronger and more durable
Catch fire soon cannot withstand high temperature.	It has an added advantage in its refractoriness.
It is easy to be worked	It is difficult to be worked.

Q.10. Discuss structure of wood with suitable diagram. explain annual ring?

**Ans.** Structure diagram of wood: -

Structure of Timber Tree

1. Pith
2. Heart Wood
3. Sap Wood
4. Cambium Layer
5. Inner Bark or Bast
6. Outer Bark or Cortex
7. Annual Rings
8. Medullary Rays

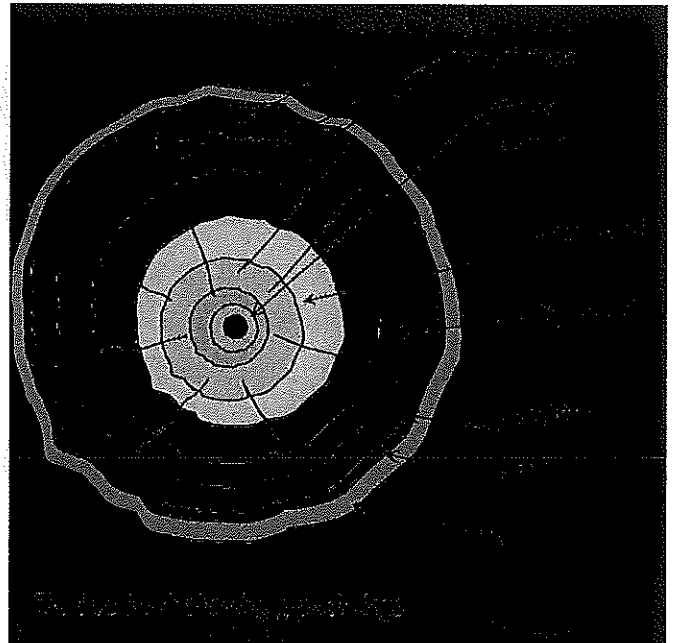

**Annual Ring: -**

Each year, the tree forms new cells, arranged in concentric circles called annual rings or annual growth rings. These annual rings show the amount of wood produced during one growing season. Then, towards the end of the summer, growth slows down. The cells manufactured at this time of year are small, with thick walls. They form the summerwood (latewood) which appears as a darker ring on the tree cross section. One year of growth is



## BHARTIYA SKILL DEVELOPMENT UNIVERSITY

therefore represented by a ring consisting of a light part and a dark part. The darker wood is not formed in winter, as some people believe, because the cambium is completely inactive in the winter. The following year, a new two-part ring is added. The older rings are closest to the center of the tree. The tree grows in diameter because it manufactures new cells around its circumference, not because the old cells get larger.

Q.11. What is seasoning process also explain its types?

**Ans.** Seasoning of timber is the process of drying or removing the moisture or Sap presents in a freshly felled timber, under more or less controlled conditions. Freshly felled timber contains a large humidity of moisture roughly from 100 to 200%, based upon dry weight of wood. If the timber is used without seasoning it is liable to shrink, warp and crack.

Methods of Seasoning

1. Natural Seasoning

(a) Air Drying/ seasoning      (b) Water Seasoning

2. Artificial Seasoning

(a) Kiln Seasoning      (b) Chemical Seasoning      (c) Electrical Seasoning

**Natural Seasoning**

**(a) Air Seasoning: -**

In this method of seasoning the sawn timber is stacked in a dry place about 30 cm above floor level with longitudinal and crosspieces arranged one upon another, leaving a space of a few Centimeters for free circulation of air. Wood fit for carpenter's work after 2 years and for painter's work after 4 years.

**(b) Water Seasoning: -**

This method of seasoning timber consists in keeping logs of wood completely immersed in a running stream of water, the longer ends of the log being kept pointing up-stream. By this process, the sap, sugar and gum etc are leached out of the wood and replaced by water. The logs are then taken out and left to dry in an open place.

**2. Artificial Seasoning**

**(a) Kiln Seasoning: -** The timber is seasoned under controlled temperature and humidity conditions with proper circulation and ventilation system. The rise in temperature should be such that the timber retains the original strength and elastic properties. The required humidity level is maintained to avoid warping and cracking. The drying of timber at uniform rate is well maintained by circulating hot air by fans and a certain amount of steam is added in order to retain correct humidity. The ventilation is provided to avoid overheating and excessive humidity. The timber inside the chamber, on trolley is kept under controlled conditions for about fortnight or depending upon the initial water content and required moisture level. The quality of wood is inferior as compared to the one seasoned by natural seasoned methods.

**b) Chemical Seasoning: -** It is also known as salt seasoning. In the method, the timber is immersed in a solution of soluble salt. It is then taken out and seasoned in ordinary way.



## BHARTIYA SKILL DEVELOPMENT UNIVERSITY

The interior surface of timber dries in advance of exterior one and chances of formation of external cracks are reduced.

**(C) Electrical Seasoning:** - This method of seasoning works on the principle that heat is produced when poor conductor is placed in the field of high frequency. The wooden planks are made to pass through an induction coil producing high frequency. Due to an induction effect moisture contents in the wood is dried quickly. This method of drying is employed in plywood manufacturing process. This method is not popular because of prohibitive cost, lack of control moisture content, sudden drying damage wooden fibers.



**BHARTIYA SKILL DEVELOPMENT UNIVERSITY****School of Carpenter Skills****1<sup>st</sup> Semester, 1<sup>st</sup>In-Sem. Examination****B. Voc. Program, Summer Semester (2018-19)****Course Code: SCS1106****Time: 1 Hour****Course Name: Hand Drawing****Max. Marks: 20****Instructions:**

1. Answer all questions from section A, each question carries one mark.
2. Answer all question from section B, each question carries two marks.
3. Answer all question from section C, each question carries three marks.

**Section – A****05X01 = 05 Marks****Q.1. Which one of the following indicates a Centre line?**

- (a)  (b) 
- (c)  (d) 

**Q.2 Which one of the following projection angle methods is not used in carpentry drawing?**

- (a) First angle (b) Second angle  
(c) third angle (d) None of these

**Q.3. How many units can be calculated in Diagonal scale?**

- (a) 1 (b) 2  
(c) 3 (d) 4

**Q.4. Which one of the following angle of projections follows sequence of Observer - plan of projection – object?**

- (a) First angle of projection (b) Second angle of projection  
(Cc) third angle of projection (d) Fourth angle of projection

**Q.5. Original dimension of the object is 500 mm and it is in drawing of 250. What will be the scale ratio?**

- (a) 1:1 (b) 1:2  
(c) 2:1 (d) None of these



## BHARTIYA SKILL DEVELOPMENT UNIVERSITY

### Section – B

03X02 = 06 Marks

- Q.6. Differentiate between First angle projection and Third angle projection.
- Q.7. Describe various types of lines used in hand drawing.
- Q.8. What are projection of points? Draw projection of points (4,8), (3,6), (-6,6) on coordinate axis.

### Section – C

03X03 = 09 Marks

- Q. 9. Explain various types of scale used in hand drawing.
- Q.10. Explain the importance of hand drawing in carpentry. How is it related to quality of product?
- Q.11. Discuss various types of views used in drawing with examples.





**BHARTIYA SKILL DEVELOPMENT UNIVERSITY****School of Carpenter Skills****1<sup>st</sup> Semester, 1<sup>st</sup>In-Sem. Examination****B. Voc. Program, Summer Semester (2018-19)****Course Code: SCS1106****Time: 1 Hour****Course Name: Hand Drawing****Max. Marks: 20****Instructions:**

1. Answer all questions from section A, each question carries one mark.
2. Answer all question from section B, each question carries two marks.
3. Answer all question from section C, each question carries three marks.

**Section – A**

05X01 = 05 Marks

Q.1. Which one of the following indicates a Centre line?

- (a)  (b) 
- (c)  (d)  (C)

Q.2 Which one of the following projection angle methods is not used in carpentry drawing?

- (a) First angle (b) Second angle
- (c) third angle (d) None of these (B)

Q.3. How many units can be calculated in Diagonal scale?

- (a) 1 (b) 2
- (c) 3 (d) 4 (C)

Q.4. Which one of the following angle of projections follows sequence of Observer - plan of projection – object?

- (a) First angle of projection (b) Second angle of projection
- (Cc) third angle of projection (d) Fourth angle of projection (C)

Q.5. Original dimension of the object is 800 mm and it is in drawing of 400. What will be the scale ratio?

- (a) 1:1 (b) 1:2
- (c) 2:1 (d) None of these (B)

# BHARTIYA SKILL DEVELOPMENT UNIVERSITY

## Section – B

03X02 = 06 Marks

Q.6. Differentiate between First angle projection and Third angle projection.

Ans.

FIRST ANGLE PROJECTION	THIRD ANGLE PROJECTION
Observer – object – plan of projection	Observer – plan of projection – object
View stays in first quadrant .	View stays in third quadrant.
This is used in India.	This is used in European country.
Dimensions are drawn up to the axis line.	Dimension are drawn below to the axis line.

Q.7. Describe various types of lines used in hand drawing.

Ans.

1. **Continuous Thick line:** This line is used for visible out line and visible Edges
2. **Continuous thin or straight curve line:** This line is used for Imaginary lines of intersection, dimension line, projection line, leader line, hatching line, short centre line.
3. **Continuous thin freehand:** This line is used for limits of partial or interrupted views and section.
4. **Dashed thick line:** This line is used for Hidden outline and hidden edges.
5. **Dashed thin line:** This line is used for hidden out line and hidden edges.
6. **Chain thin:** This line is used for centre lines and lines of symmetry

Q.8. What are projection of points? Draw projection of points (4,8), (3,6), (-6,6) on coordinate axis.

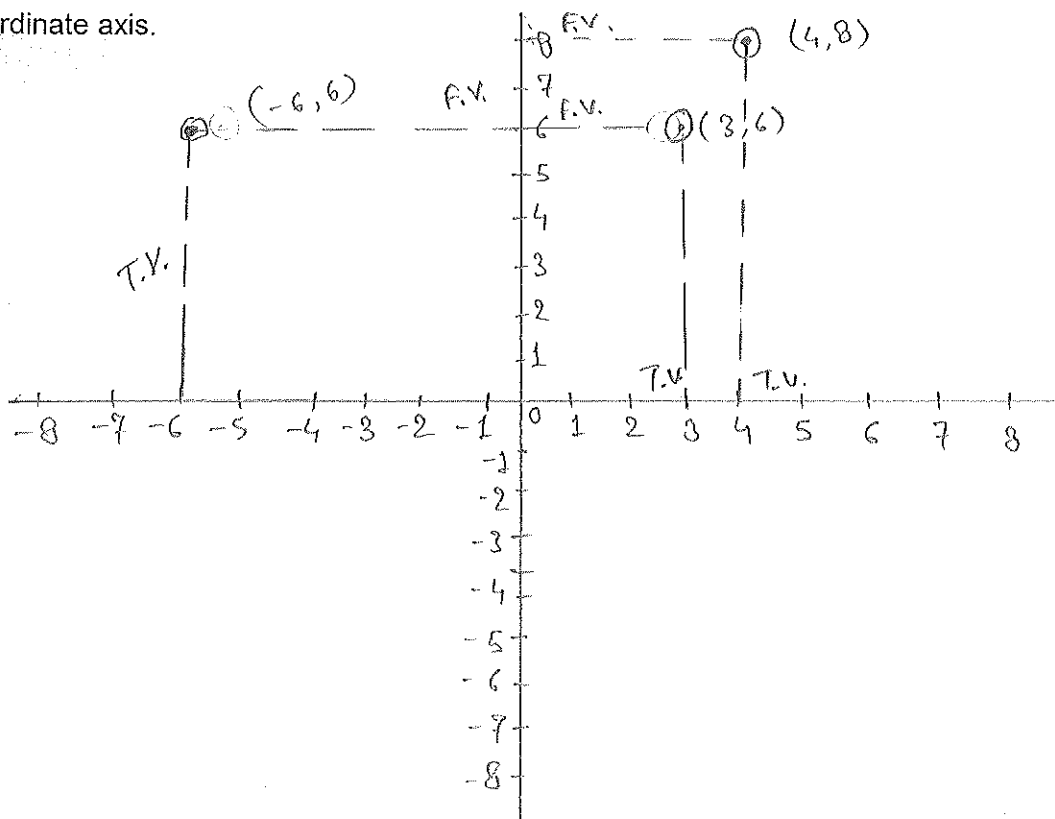

# BHARTIYA SKILL DEVELOPMENT UNIVERSITY

## Section – C

03X03 = 09 Marks

Q. 9. Explain various types of scale used in hand drawing.

Ans.

1. **Plain scale:** A scale which is used to measure maximum two units and minimum one.
2. **Diagonal scale:** A scale which is used to measure maximum 3 units and minimum two units.
3. **Scale of chord:** It is used to measure angle on large field area where protector is not possible to measure angle.

Q.10. Explain the importance of hand drawing in carpentry. How is it related to quality of product?

Ans.

Importance of hand drawing.

1. To know visualization of product.
2. In assembly of joints.
3. Product reality
4. Product quality
5. To check error in product.

It is true that quality of product is related to drawing because of the assembly and connections of joints are totally based on the drawing and this is so important to get qualitative product drawing has to be realistic and qualitative.

Q.11. Discuss various types of views used in drawing with examples.

Ans. Top view, Front view, side view.

