

**BHARTIYA SKILL DEVELOPMENT UNIVERSITY**

School of Woodworking Skills

B. Voc. Program, Summer Semester (2019-20)

I Semester, End-Sem. Examination

Course Code: SCS1101

Time: 2 Hour

Course Name: Hand skill & measurement transfer

Max. Marks: 50

Instruction:

- Answer all questions from section A, each question carries one mark.
- Answer all questions from section B, each question carries four marks.
- Answer all questions from section C, each question carries six marks.

Section – A

10X01 = 10 Marks.

Q.1.Which one of the following is a planning tool?

- (a) Try square (b) screw driver
(c) Japanese pull saw (d) none of them.

Q.2.Which one of the following is a marking tool?

- (a) Manual hand planer (b) Perforated chisel
(c) Try square (d) None of them

Q.3.Which one of the following saw is used to make dovetail joint?

- (a) Indian saw (b) Japanese saw
(c) Coping saw (d) back saw

Q.4.Which one of the following is not the application of try square?

- (a) Used to make straight line. (b) Used to check surface flatness
(c) Used to make curved lines. (d) all of the above

Q.5.Which one of the following is the angle of miter cut?

- (a) 45° (b) 60°
(c) 30° (d) 25°

Q.6. Which one of the following is soft wood?

- (a) Pine (b) Teak
(c) Acacia (d) Sal

Q.7.Which one of the following is used to make the surface smooth?

- (a) Hammer (b) Hand Saw
(c) Marking Gauge (d) Sand Paper



BHARTIYA SKILL DEVELOPMENT UNIVERSITY

Q. 8. Which one of the following is not a marking tool?

- (a) Try square (b) Steel ruler
(c) Jack planer (d) Marking gauge

Q. 9. What should you do in case you have damaged a tool while working?

- (a) Report to the trainer (b) leave it unattended
(c) Ignore the tool (d) None of the above

Q.10. which one of the following tool is used to mark lines of different angle?

- (a) Try square (b) Miter gauge
(c) Angle gauge (d) Marking gauge

Section – B

04X04 = 16 Marks

Q.11. What is measuring transfer? List the names of five measuring tools.

Q. 12. Write down the names of four cutting tools and define them.

Q.13. What is a try square? Mention its uses.

Q. 14. Write a short note on marking gauge.

Section – C

04X06 = 24 Marks

Q.15. Draw six marking Symbols and write about their scopes.

Q.16 Differentiate between groove, rebate and profile with the help of diagram.

Q.17. What is a carpenter triangle and why do we use it?

Q.18. What are the general safety precautions that should be followed in the training center?

**BHARTIYA SKILL DEVELOPMENT UNIVERSITY****School of Woodworking Skills****B. Voc. Program, Summer Semester (2019-20)****I Semester, End-Sem. Examination****Course Code: SCS1101****Time: 2 Hour****Course Name: Hand skill & measurement transfer****Max. Marks: 50****Instruction:**

- Answer all questions from section A, each question carries one mark.
- Answer all questions from section B, each question carries four marks.
- Answer all questions from section C, each question carries six marks.

Section – A**10X01 = 10 Marks.**

Q.1. Which one of the following is a planning tool?

- (a) Try square (b) screw driver
(c) Japanese pull saw (d) none of them. (d)

Q.2. Which one of the following is a marking tool?

- (a) Manual hand planer (b) Perforated chisel
(c) Try square (d) None of them (c)

Q.3. Which one of the following saw is used to make dovetail joint?

- (a) Indian saw (b) Japanese saw
(c) Coping saw (d) Back saw (c)

Q.4. Which one of the following is not the application of try square.

- (a) Used to make straight line. (b) Used to check surface flatness
(c) Used to make curved lines. (d) all of the above (c)

Q.5. Which one of the following is the angle of miter cut?

- (a) 45° (b) 60°
(c) 30° (d) 25° (a)

Q.6. Which one of the following is soft wood?

- (a) Pine (b) Teak
(c) Acacia (d) Sal (a)

Q.7. Which one of the following is used to make the surface smooth?

- (a) Hammer (b) Hand Saw
(c) Marking Gauge (d) Sand Paper (d)

BHARTIYA SKILL DEVELOPMENT UNIVERSITY

Q. 8. Which one of the following is not a marking tool?

- (a) Try square (b) Steel ruler
(c) Jack planer (d) Marking gauge (c)

Q. 9. What should you do in case you have damaged a tool while working?

- (a) Report to the trainer (b) leave it unattended
(c) Ignore the tool (d) None of the above (a)

Q.10. which one of the following tool is used to mark lines of different angle.

- (a) Try square (b) Miter gauge
(c) Angle gauge (d) Marking gauge (c)

Section – B

04X04 = 16 Marks

Q.11. What is measuring transfer. List the names of five measuring tools.

Marking transfer means the transfer of the dimension and shapes from the drawing on the wood

The following tools are used for measuring

Steel meter

Roll meter

Dowel meter

Vernier calipers

Marking gauge

Q12. Write down the names of three cutting tools and define them.

Crosscut Saw or Ripsaw:

A crosscut saw is used to make straight cuts across the grain of the wood. The teeth of a crosscut saw are pointed like a knife and cut on both the forward and backward strokes of the blade.

Back saw:

A backsaw is commonly used in cutting joints. It is frequently positioned in a miter box (device used to guide the angle of a cut) to make very accurate cuts in smooth lumber. This saw is similar to a crosscut saw, but it has a reinforced, metal spine and finer cutting teeth.

Japanese pull saw:

A Japanese pull saw is a cutting tool used to cut wooden pieces. It usually cuts materials in the backward stroke.

BHARTIYA SKILL DEVELOPMENT UNIVERSITY

Q.13. What is a try square. Mention its uses.

A try square is a hand tool that comes under the category of marking tools.

It is commonly used for

Transferring straight lines to the work piece

For checking the flatness of any surface.

14. Write a short note on marking gauge.

A marking gauge is a marking tool which is used to transfer lines on the wood piece.

It is used to transfer lines on those parts where it is not possible to transfer lines by

try square. The marking gauge consists of a nail whose sharp edges are used to

mark precise lines. It is mostly used to mark lines along the grain.

Section – C

04X06 = 24 Marks

Q.15. Draw five marking Symbols and write about their scopes.

Cross

The scope of this symbol is

Through out cut.

Continuous separation cut, cut off cut

Wave line

The scope of this symbol is

material that is removed throughout

Hatching

The scope of this symbol is:

Material that is partially removed, not through-out,

e.g. hatching for notches

Arrow

The scope of this symbol is:

Limitation of machining operations, e.g. for groove,

Rebate.

Cross exactly across the diagonal

The scope of this symbol is

Mortice hole.

Q.16. Differentiate between groove, rebate and profile with the help of diagram.

BHARTIYA SKILL DEVELOPMENT UNIVERSITY

Groove

The edge of groove are indicated
Symbolically by lines. The G denotes
The groove.



Rebate

The edges of the rebate are
indicated symbolically by lines.
The "R" indicates the rebate.
A decorative rebate is also called
a rebate, not a profile.

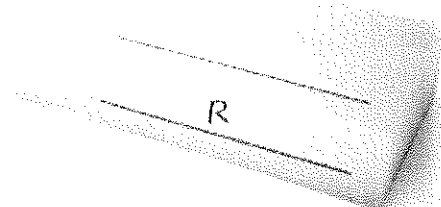

Profile

The edges of profile are indicated
Symbolically by lines.
The p denotes the profile.

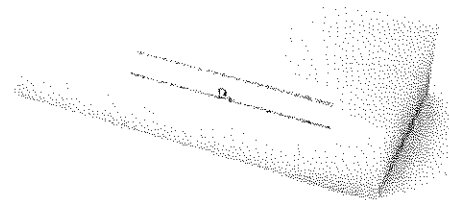

Q.17. What is a carpenter triangle and why do we use it.

We use symbols to combine work piece together. The symbol that is used to combine is called triangle sign. The aim of drawing symbol is that the individual parts of the work are evaluated at the same time and by each person. Sometimes we use the left part instead of the right part and the top part instead of the bottom because there are several identical pieces of the same size, so we need to number them accordingly and this can be done by making triangle sign. The sign should not be too small. It should be clearly visible. It should be drawn from the bottom to the top and from front to back.

Q.18. What are the general safety precautions that should be followed in the training center.

The following are general safety procedures that apply to almost every work situation.

- Adhere to instructions.
- Read labels and warnings on containers and tools.
- Follow the manufacturer's recommendations for use and maintenance of a specific tool.
- Pay attention to signs posted in the work area.
- Follow the instructor's directions.
- Wear safety glasses in the shop at all times.
- Wear protective gear such as gloves, earplugs, and safety shoes if appropriate.



BHARTIYA SKILL DEVELOPMENT UNIVERSITY

- Do not wear loose-fitting clothing that could get caught in a moving part.
 - Wear a hair net to prevent long hair from getting caught in a tool.
 - Keep work areas clean and free of clutter.
 - Inspect each tool before using it to make sure it is working properly.
 - Tell the instructor about any damaged tool.
 - Do not use a tool that is not working properly.
- Return each tool to its proper place of storage



BHARTIYA SKILL DEVELOPMENT UNIVERSITY

School of Woodworking skills

Session: 2019-20 (Summer Semester)

B. Voc. Program, 1st Semester,

End-Sem. Examination

Course Code: SCS1102

Time: 2 Hour

Course Name: Handy machine

Max. Marks: 50

Instruction:

1. Answer all questions from section A, each question carries one mark.
2. Answer all questions from section B, each question carries four mark.
3. Answer all questions from section C, each question carries six mark.

Section – A

10X01 = 10 Marks

Q.1.Which one of the following is the accessory belongs to Jig Saw?

- (A) Guide rail (B) Riving knife
(C) Side stops (D) Perfect Circles

Q.2.Which one of the following is the Handy machine used for making back wall groove?

- (A) Hand Circular Saw (B) Jig Saw
(C) Hand router (D) Both (A) & (C)

Q.3.Which one of the following is the outer clearance for domino dowels results from the machine stop?

- (A) 20 mm (B) 40 mm
(C) 37 mm (D) 35 mm

Q.4.Which one of the following is the accessory belongs to Domino machine?

- (A) Guide rail (B) Splinter Guide
(C) Trim Stop (D) None of these

Q.5.Which one of the following is the set of depth used by 5 mm cutter in Domino machine?

- (A) (12,15,20) mm (B) (10,15,20) mm
(C) (28,10,20) mm (D) None of these

Q.6.Which one of the following is the minimum distance between two domino dowels for joining?

- (A) (200 – 300) mm (B) (250 – 300) mm
(C) (100 – 150) mm (D) None of these

Q.7.Which one of the following is the material used for making domino dowels?

- (A) Pine (B) Oak
(C) Beech (D) Mango

Q.8.Which one of the following is the routing depth taken while using 4 mm Domino cutter?

- (A) 12 mm (B) 20 mm
(C) 28 mm (D) 15 mm



BHARTIYA SKILL DEVELOPMENT UNIVERSITY

Q.9. Which one of the following is the accessory does not belong to Domino machine?

(A) Cross Stop

(B) Trim Stop

(C) Additional Stop

(D) Guide rail

Q.10. Which one of the following is the handy machines used with Guide rail for cutting?

(A) Hand router

(B) Hand Circular Saw

(C) Jig Saw

(D) Domino

Section – B

04X04 = 16 Marks

Q.11. What are the two ways of Guiding of Jig Saw? Explain them.

Q.12. Explain the pendulum adjustment in Jig Saw with the help of ^a diagram?

Q.13. Explain any five parts of Jig Saw machine.

Q.14. Draw the diagram of different sizes of Domino dowels and also mention the benefits of using Domino dowels in Joining.

Section – C

04X06 = 24 Marks

Q.15. Draw the diagram of saw blade used in Hand Circular Saw. Also mention its specifications.

Q.16. What are the basic procedure for safe and efficient while using Jig Saw?

Q.17. What are the types of Hand Circular Saw? Explain them.

Q.18. Explain any five parts of Domino and Hand Circular Saw.

BHARTIYA SKILL DEVELOPMENT UNIVERSITY

School of Woodworking skills

Session: 2019-20 (Summer Semester)

B. Voc. Program, 1st Semester,

End-Sem. Examination

Course Code: SCS1102

Time: 2 Hour

Course Name: Handy machine

Max. Marks: 50

Instruction:

1. Answer all questions from section A, each question carries one mark.
2. Answer all questions from section B, each question carries four mark.
3. Answer all questions from section C, each question carries six mark.

Section – A

10X01 = 10 Marks

Q.1.Which one of the following is the accessory belongs to Jig Saw?

- (A) Guide rail (B) Riving knife
(C) Side stops (D) Perfect Circles (D)

Q.2.Which one of the following is the Handy machine used for making back wall groove?

- (A) Hand Circular Saw (B) Jig Saw
(C) Hand router (D) Both (A) & (C) (D)

Q.3.Which one of the following is the outer clearance for domino dowels results from the machine stop?

- (A) 20 mm (B) 40 mm
(C) 37 mm (D) 35 mm (C)

Q.4.Which one of the following is the accessory belongs to Domino machine?

- (A) Guide rail (B) Splinter Guide
(C) Trim Stop (D) None of these (C)

Q.5.Which one of the following is the set of depth used by 5 mm cutter in Domino machine?

- (A) (12,15,20) mm (B) (10,15,20) mm
(C) (28,10,20) mm (D) None of these (A)

Q.6.Which one of the following is the minimum distance between two domino dowels for joining?

- (A) (200 – 300) mm (B) (250 – 300) mm
(C) (100 – 150) mm (D) None of these (C)

Q.7.Which one of the following is the material used for making domino dowels?

- (A) Pine (B) Oak
(C) Beech (D) Mango (C)

Q.8.Which one of the following is the routing depth taken while using 4 mm Domino cutter?

- (A) 12 mm (B) 20 mm
(C) 28 mm (D) 15 mm (B)

BHARTIYA SKILL DEVELOPMENT UNIVERSITY

Q.9. Which one of the following is the accessory does not belong to Domino machine?

- (A) Cross Stop (B) Trim Stop
(C) Additional Stop (D) Guide rail (D)

Q.10. Which one of the following is the handy machines used with Guide rail for cutting?

- (A) Hand router (B) Hand Circular Saw
(C) Jig Saw (D) Domino (B)

Section – B

04X04 = 16 Marks

Q.11. What are the two ways of Guiding of Jig Saw? Explain them.

ANS: (a) From bottom of the work piece: - Guide the machine to the bottom of the work piece, if only one side of a work piece is visible. The jig saw is usually rotated and inserted from below. In this way, we can see the cutting line when sawing.

(b) From top of the work piece: - If the quality of the cut does not matter much, it is usually easier to cut at the top.

Q.12. Explain the pendulum adjustment in Jig Saw with the help of diagram?

ANS: Pendulum adjustment: - In most jig saws, there are three different pendulum adjustable levels. At a high speed, the number of strokes is greater, the machine performs more stroke. The appropriate number of strokes depends on material and feed. The switchable pendulum additionally pushes the saw blade forward during the upward movement so that it cuts more aggressively.

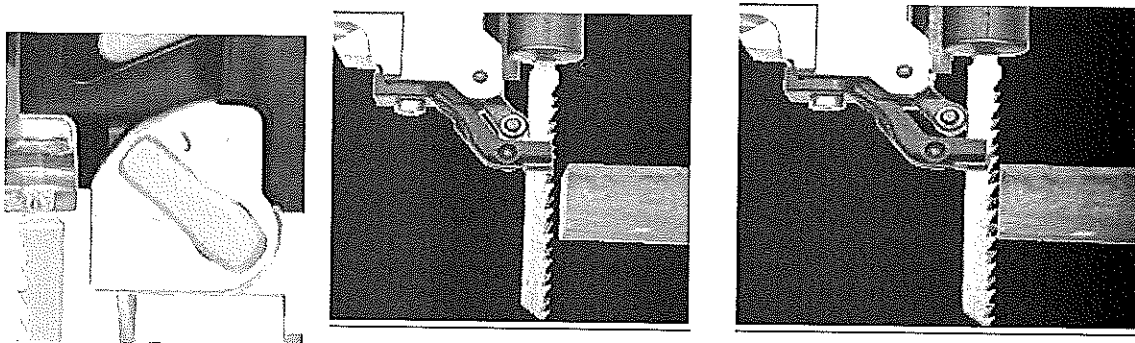

Q.13. Explain any five parts of Jig Saw machine.

ANS: 1. Engine head 2. Grip knob 3. Drive unit (rod motor) 4. Speed control
5. Chip guard 6. Pendulum lever 7. Left & right power switch

Q.14. Draw the diagram of different sizes of Domino dowels and also mention the benefits of using Domino dowels in Joining.

ANS:

Benefits of using Domino dowels in Joining:

a. Strong joint.

BHARTIYA SKILL DEVELOPMENT UNIVERSITY

b. Easy to assemble.

Section – C

04X06 = 24 Marks

Q.15. Draw the diagram of saw blade used in Hand Circular Saw. Also mention its specifications.

ANS:

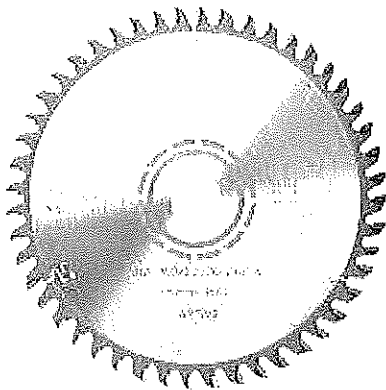

Specifications:

1. Blade diameter- 160 mm
2. Depth of cut- 55 mm

Q.16. What are the basic procedure for safe and efficient while using Jig Saw?

ANS: Basic procedure for safe and efficient work:

1. Determine material properties.
2. Clamp the suitable saw blade.
3. Make the necessary setting and select auxiliaries.
4. If necessary make a test piece.
5. Connect machine with a dust collector or vacuum cleaner

Q.17. What are the types of Hand Circular Saw? Explain them.

ANS: 1. Hand circular saw with dipping saws: - In this type of Hand circular saw, the saw blade is at rest with the table flush. When sawing, the saw blade is lowered by actuating the unlocking mechanism.

2. Hand circular saw with swing protective hood: - In this type of Hand circular saw, sawing protective hood for circular saws with anti-away hood, the lower part of the saw blade is concealed by a movable guard, which is only pushed back by the latter when it penetrates into the work piece.

Q.18. Explain any five parts of Domino and Hand Circular Saw.

ANS:

S.no	Part name
1	Secondary handle
2	Locking lever lock
3	Domino hole depth locking lever
4	Angle stop clamping lever
5	Material thickness preselect slider

BHARTIYA SKILL DEVELOPMENT UNIVERSITY

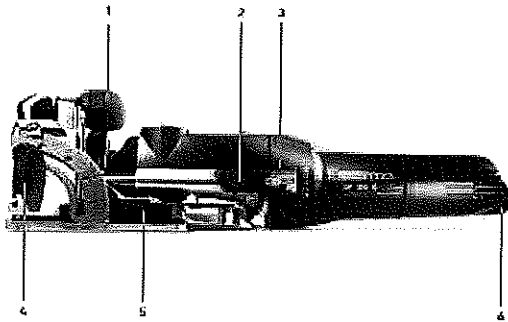



School of Woodworking skills

Session: 2019-20 (Summer semester)

B. Voc. Program, I Semester,

End-Sem. Examination

Course Code: SCS1103

Time: 2 Hours

Course Name: Standard Machine

Max. Marks: 50

Instruction:

- All questions from section A, each question carries one mark.
- All questions from section B, each question carries Four marks.
- All questions from section C, each question carries six marks.

Section – A

10X01 = 10 Marks

Q.1. Which one of the following is the function of riving knife?

- (a) It avoids kick back
- (b) it keeps the work piece in motion
- (c) It makes the cut smooth
- (d) all of them

Q.2. Which one of the following is the distance between riving knife and main saw in panel saw?

- (a) 5-8 mm
- (b) 1-2 mm
- (c) 8-10 mm
- (d) 3-5 mm

Q.3. Which one of the following distance between the work piece and the safety cover of the band saw is the correct setting?

- (a) 50 mm
- (b) 25 mm
- (c) 10 mm
- (d) it does not matter

Q.4. Which one of the following is controlled on the outfeed table of the surface planner?

- (a) Angle
- (b) thickness
- (c) height
- (d) depth

Q.5. which one of the following is the function of scoring saw blade?

- (a) It is used to avoid chip out
- (b) used to make curves
- (c) Used to make a groove
- (d) none of them

Q.6. Which one of the following is the fastened position of riving knife?

- (a) behind of the cutting blade
- (b) front of the cutting blade
- (c) top of the cutting blade
- (d) all of them

Q.7. Which one of the following is the function of Protective hood?

- (a) It avoids kick back
- (b) it keeps the work piece in motion



BHARTIYA SKILL DEVELOPMENT UNIVERSITY

- (c) It makes the cut smooth (d) all of them

Q.8. Which one of the following position of the panel saw blade for cleanness cut?

- (a) blade should be low (b) blade should be in middle
(c) blade should be high (d) it does not matter

Q.9. Which one of the following is controlled on the outfeed table of the surface planner?

- (a) thickness (b) angle
(c) height (d) depth

Q.10. which one of the following material we use for the table insert in band saw machine?

- (a) plastic (b) wood
(c) iron (d) rubber

Section – B

04X04 = 16 Marks

- Q.11. Write down the step by step instruction how to turn on a machine with a star - delta starter with figure.
Q.12. Write down the setting of the fence on the surface planner step by step.
Q.13. Write down the function of riving knife.
Q.14. Write down the function of the protection hood on the panel saw

Section – C

04X06 = 24 Marks

- Q.15. Explain the difference between a high and low saw position of the panel saw.
Q.16. Write down the safe and efficient hand position while working on the surface planner.
Q.17. Briefly explain the sequential steps to change the panel saw blade.
Q.18. Briefly explain the cutting saw blade construction and function.



School of Woodworking skills

Session: 2019-20 (Summer semester)

B. Voc. Program, I Semester,

End-Sem. Examination

Course Code: SCS1103

Time: 2 Hours

Course Name: Standard Machine

Max. Marks: 50

Instruction:

- All questions from section A, each question carries one mark.
- All questions from section B, each question carries Four marks.
- All questions from section C, each question carries six marks.

Section – A

10X01 = 10 Marks

Q.1. Which one of the following is the function of riving knife?

- (a) It avoids kick back (b) it keeps the work piece in motion
(c) It makes the cut smooth (d) all of them (a)

Q.2. Which one of the following is the minimum distance between riving knife and main saw in panel saw?

- (a) 5-8 mm (b) 1-2 mm (d)
(c) 8-10 mm (d) 3-5 mm

Q.3. Which one of the following distance between the work piece and the safety cover of the band saw is the correct setting?

- (a) 50 mm (b) 25 mm (c)
(c) 10 mm (d) it does not matter

Q.4. Which one of the following is controlled on the outfeed table of the surface planner?

- (a) Angle (b) thickness (a)
(c) height (d) depth

Q.5. which one of the following is the function of scoring saw blade?

- (a) It is used to avoid chip out (b) used to make curves (a)
(c) Used to make a groove (d) none of them

Q.6. Which one of the following is the fastened position of riving knife? (a)

- (a) behind of the cutting blade (b) front of the cutting blade
(c) top of the cutting blade (d) all of them

Q.7. Which one of the following is the function of Protective hood? (a)

- (a) It avoids kick back (b) it keeps the work piece in motion



- (c) It makes the cut smooth (d) all of them
- Q.8. Which one of the following position of the panel saw blade for cleanness cut?
(a) blade should be low (b) blade should be in middle (a)
(c) blade should be high (d) it does not matter
- Q.9. Which one of the following is controlled on the outfeed table of the surface planner?
(a) thickness (b) angle (b)
(c) height (d) depth
- Q.10. which one of the following material we use for the table insert in band saw machine?
(a) plastic (b) wood (b)
(c) iron (d) rubber

Section – B

04X04 = 16 Marks

Q.11. Write down the step by step instruction how to turn on a machine with a star – delta starter with figure.

Ans. Pad lockable main switch arrange on electric cubicle. To switch on /off for the power supply. Emergency button to switch the power off of the motor supply voltage. Turn the starter to delta after some second turn it to star for starting the motor. Turn the starter to 0 for stopping the motor.

Q.12. Write down the setting of the fence on the surface planner step by step.

Ans. Adjustment –

1. Add at right angle
2. Chamfer / slopes
3. Chamfer / bevels suitable for the small parts

Right angle –

Suitable for small parts planning right angle the angle stop is set to 90° is controlled on the out feed table with a precise angle.

Bevels –

Chamfer and sloop planning, the stop is adjusted with the bevel.

This is controlled on the out feed table.



Q.13. Write down the function of riving knife.

1. Ans. The riving knife is fastened behind the saw blade.
2. Its keeps the kerf open in separating cuts.
3. If the riving knife is missing, the joint can be closed by the compression in the wood.
4. Riving knife allows the ascending part of the sprocket to grasp the work piece.
5. Riving knife must be thinner than the cutting width (tooth thickness) of the cutting blade.

Q.14. Write down the function of the protection hood on the panel saw.

Ans.

1. Protective hood use protection against contact with the circular saw blade.
 2. Preventing a work piece kickback.
 3. Protection against splintering wood parts, branches and sawdust extraction of the chips.
- Sawblade protection hood for straight cut.
Protection hood for mitre cut.

Section – C

04X06 = 24 Marks

Q.15. Explain the difference between a high and low saw position of the panel saw.

Ans.

Effect	High saw blade position	Low saw blade position
Cut cleanness	If saw blade is in high position, then more chip out will be produce on the bottom side.	If saw blade is in low position then the chip out on the bottom side will be less.
Security	Lower risk of kickback / cutting pressure directed down to the machine table.	Greater risk of kick back / cutting pressure tend to be directed towards the operator(feed resistance increases)
Service life of saw blade	Higher due to shorter cutting path in work piece.	Lower due to longer cutting path in work piece and more cutting pressure.



BHARTIYA SKILL DEVELOPMENT UNIVERSITY

Q.16. Write down the safe and efficient hand position while working on the surface planner.

Ans. Safe and efficient work –

- Hand position
- Pressure distribution

Hand position when planning –

When planning the wood, the hand should be open and flat on the workpiece.

The finger is closed.

The concave side of the work piece placed on the feed table.

Hand position when planning –

When planning wood, the thumbs are on the top edge, the other fingers rolled, and the push the work piece against the stop.

Pressure distribution –

When planning the work piece, the pressure on the work piece should be on the out feed table.

Q.17. Briefly explain the sequential steps to change the panel saw blade.

Ans. Changing the saw blade –

1. Press main switch off.
2. Switch on the emergency stop switch.
3. Set the saw to the upper limit setting and cutting angle should be 0° .
4. Remove the safety hood.
5. Place the sliding table at upper limit.
6. Open the safety Gard, block the circular saw shaft.
7. Unscrew the nut with ring spanner in the clockwise (sawing-) direction.
8. Release nut in running direction.
9. Remove the saw blade.
10. Never put the saw blade and machine tools directly on the machine table, otherwise cutting teeth could be damaged.
11. Clean the blade holder flange.
12. Select the suitable blade and place in shaft.
13. Fit the flange and nut.
14. Tight the nut against running direction.
15. Release the locking device.

Q.18. Briefly explain the cutting saw blade construction and function.

Ans. Along the grains cut –

if we are cutting along the grains, the cutting blade angle should be positive rake angle.

The number of teeth is less in this blade.



For cross cut –

if we are cutting cross the grains, the cutting blade angle should be positive rake angle.

The number of teeth is more in this blade.

For plastic and aluminum –

If we are cutting plastic and aluminum, the cutting blade angle should be negative rake angle. The number of teeth is more in this blade.

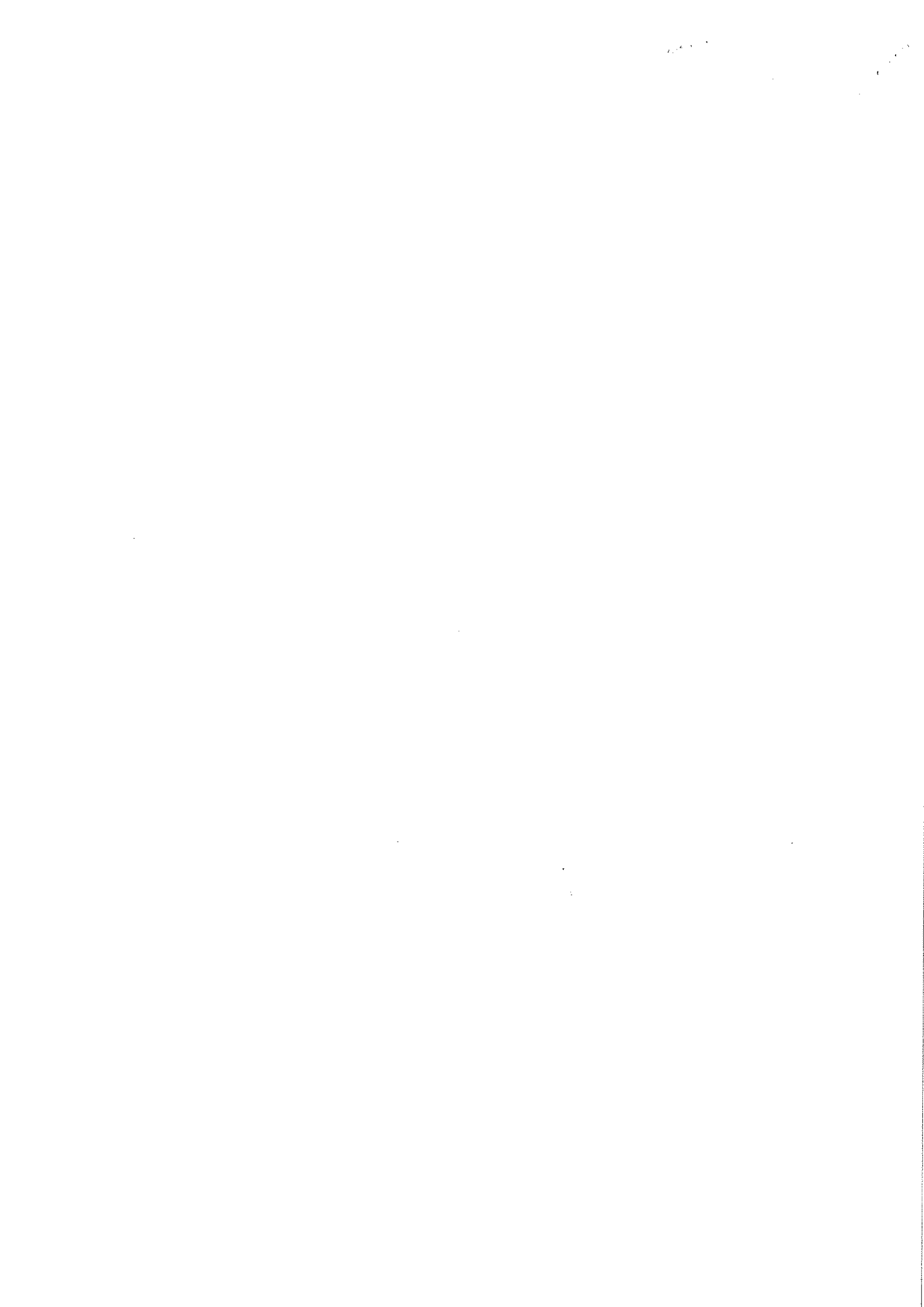



BHARTIYA SKILL DEVELOPMENT UNIVERSITY

School of Woodworking Skills

B. Voc. Program, Summer Semester (2019-20)

I Semester, End-Sem. Examination

Course Code: SCS1104

Time: 2 Hour

Course Name: Assembly

Max. Marks: 50

Instruction:

- Answer all questions from section A, each question carries one mark.
- Answer all questions from section B, each question carries four marks.
- Answer all questions from section C, each question carries six marks.

Section – A

10X01 = 10 Marks.

Q.1. Which one of the following is the example of joint without extra connector?

- (a) Biscuit joint (b) Dowel joint
(c) lap joint (d) None of them.

Q.2. Which one of the following is the example of joint with extra connector?

- (a) Bridle joint (b) Dovetail joint
(c) Biscuit joint (d) none of them

Q.3. Which one of the following is the example of detachable joint?

- (a) Screw (b) Dowel joint
(c) Biscuit joint (d) All of the above

Q.4. Which one of the following is the direction where the top of carpenter triangle always point?

- (a) Downwards (b) Backwards
(c) Upwards (d) Right side

Q.5. which one of the following is not the example of permanent joint?

- (a) Screw (b) Clamex
(c) Nails (d) Dowels with glue

Q.6. Which one of the following is used to paste veneer to a ply board?

- (a) adhesive (glue) (b) abrasive
(c) Nails (d) screws

Q.7. which one of the following handy machine is used to make a hole?

- (a) Drill machine (b) Circular saw
(c) jig saw (d) none of them

Q.8. which one of the following handy machine is used to make biscuit joint?

- (a) Domino machine (b) lamella machine
(c) Hand drill (d) all of them



BHARTIYA SKILL DEVELOPMENT UNIVERSITY

Q.9. Which one of the following handy machine is used to make groove?

- (a) Hand drill (b) Hand router
(c) jig saw (d) all of them

Q.10. Which one of the following machine is used for curve cutting?

- (a) Circular saw (b) Jig saw
(c) Hand router (d) Hand drill

Section – B

04X04 = 16 Marks

Q.11. What is a butt joint? Write down the types of butt joint.

Q.12. What is a lap joint? Write down the types of lap joint.

Q.13. Write down the steps to make a bridle joint.

Q.14. Write down the work plan for making a joint that contains cutting and chiseling.

Section – C

04X06 = 24 Marks

Q.15. What are the points that should be considered while selecting wood for assembly?

Q.16 Write down the calculation of a dovetail joint.

Q.17. What is the importance of a carpenter triangle?

Q.18. Write down the safety instructions for handy machines.

**BHARTIYA SKILL DEVELOPMENT UNIVERSITY**

School of Woodworking Skills

B. Voc. Program, Summer Semester (2019-20)

I Semester, End-Sem. Examination

Course Code: SCS1104

Time: 2 Hour

Course Name: Assembly

Max. Marks: 50

Instruction:

- Answer all questions from section A, each question carries one mark.
- Answer all questions from section B, each question carries four marks.
- Answer all questions from section C, each question carries six marks.

Section – A

10X01 = 10 Marks.

Q.1. Which one of the following is the example of joint without extra connector.

- (a) Biscuit joint (b) Dowel joint
(c) lap joint (d) None of them. (c)

Q.2. Which one of the following is the example of joint with extra connector.

- (a) Bridle joint (b) Dovetail joint
(c) Biscuit joint (d) none of them (c)

Q.3. Which one of the following is the example of detachable joint.

- (a) Screw (b) Dowel joint
(c) Biscuit joint (d) All of the above (a)

Q.4. Which one of the following is the direction where the top of carpenter triangle always point.

- (a) Downwards (b) Backwards
(c) Upwards (d) Right side (c)

Q.5. which one of the following is not the example of permanent joint.

- (a) Screw (b) Clamex
(c) Nails (d) Dowels with glue (b)

Q.6. Which one of the following is used to paste veneer to a ply board.

- (a) adhesive (glue) (b) abrasive
(c) Nails (d) screws (a)

Q.7. which one of the following handy machine is used to make a hole.

- (a) Drill machine (b) Circular saw
(c) jig saw (d) none of them (a)

Q.8. which one of the following handy machine is used to make biscuit joint.

BHARTIYA SKILL DEVELOPMENT UNIVERSITY

- (a) Domino machine (b) lamella machine
 (c) Hand drill (d) all of them (b)
- Q.9. Which one of the following handy machine is used to make groove.
 (a) Hand drill (b) Hand router
 (c) jig saw (d) all of them (b)
- Q.10. Which one of the following machine is used for curve cutting.
 (a) Circular saw (b) Jig saw
 (c) Hand router (d) Hand drill (b)

Section – B

04X04 = 16 Marks

Q.11. What is a butt joint. Write down the types of butt joint.

A. Butt Joint:

The end of a piece of wood is butted against another piece of wood. This is the simplest and weakest joint. Of those there is the

- a) T-butt,
- b) end-to-end butt,
- c) T-lap
- d) Mitre butt and
- e) edge-to-edge butt

Q 12. What is a lap joint. Write down the types of lap joint.

A. Lap Joint

The end of a piece of wood is laid over and connected to another piece of wood.

This is the next simplest and weakest joint.

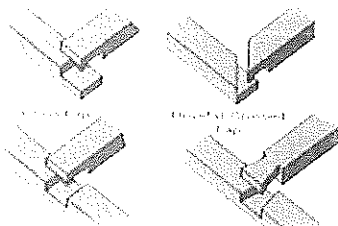

Q.13. Write down the steps to make a bridle joint.

Also known as open tenon, open mortise and tenon,





BHARTIYA SKILL DEVELOPMENT UNIVERSITY

or tongue and fork joints, this joint is where the through mortise is open on one side and forms a fork shape.

The mate has a through tenon or necked joint.

Bridle joints are commonly used to join rafter tops, also used in scarf joints and sometimes sill corner joints in timber framing.

Q.14. Write down the work plan for making a joint that contains cutting and chiseling.

- Drawing reading
- Material verification
- Triangle sign marking
- Cutting by saw
- Chiselling by chisel
- Final cutting

Section – C

04X06 = 24 Marks

Q.15. what are the points that should be considered while selecting wood for assembly.

Before combining the workpiece we must check the following.

- Wood defects (branches, resins etc)
- Surface texture
- Color difference
- Knots
- Fiber coarse and tree ring coarse

Q.16. write down the calculation of a dovetail joint.

BHARTIYA SKILL DEVELOPMENT UNIVERSITY

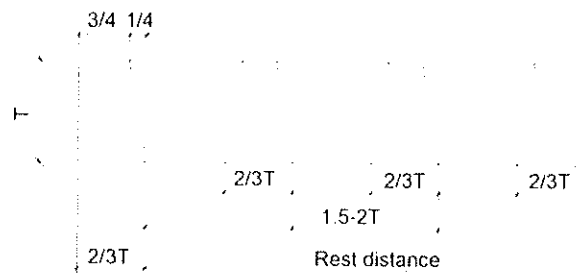

Working process -

1. Mark endtooth
2. Devide rest distance in equal parts
(one part is 1.5 - 2T)
3. Mark remainig tooth widths
4. Mark tooth - bevels

Q.17. what is the importance of a carpenter triangle.

The aim of drawing symbol is that the individual parts of the work are evaluated at the same time and by each person. Sometimes we use the left part instead of the right part and the top part instead of the bottom because there are several identical pieces of the same size, so we need to number them accordingly and this can be done by making triangle sign. The sign should not be too small. It should be cleary visible. It should be drawn from the bottom to the top and from front to back.

Q.18. Write down the safety instructions for handy machines.

- Keep work area clean and well lit.
- Do not operate power tools in explosive atmospheres, such as in the presence of flammable liquids, gases or dust.
- Keep children and bystanders away while operating a power tool.
- Never leave the electric power tool unattended.
- Power tool plugs must match the outlet. Never modify the plug in any way.
- Do not expose power tools to rain or wet conditions.
- Stay alert, watch what you are doing and use common sense when operating a power tool. Do not use a power tool while you are tired or under the influence of drugs, alcohol or medication.
- Use personal protective equipment. Always wear eye protection.
- Prevent unintentional starting. Ensure the switch is in the off-position before connecting to power source.
- Remove any adjusting key or wrench before turning the power tool on.
- Dress properly. Do not wear loose clothing or jewellery. Keep your hair and clothing away from moving parts.
- Do not force the power tool. Use the correct power tool for your application. Do not use the power tool if the switch does not turn it on and off.
- Keep cutting tools sharp and clean.
- Keep handles dry, clean and free of oil and grease.
- Ensure the switch is in the off position before inserting battery pack.



Registration No.:

BHARTIYA SKILL DEVELOPMENT UNIVERSITY





School of Woodworking Skills

Session: 2019-20 (Summer Semester)

B. Voc. Program, I Semester,

End-Sem. Examination

Course Code: GEN1104

Time: 2 Hour

Course Name: Elementary Mathematics

Max. Marks: 50

Instructions:

1. Answer all questions from section A, each question carries one mark.
2. Answer all questions from section B, each question carries two marks.
3. Answer all question from section C, each question carries three marks.

Section – A

Q 1 Which one of the following is the value of $10/10^5$?

- (A) 0.01 (B) 0.001 (C) 0.0001 (D) None of these

Q 2. How many inches are there in 3 meter?

- (A) 60.80 inch (B) 117.8 inch (C) 59.05 inch (D) 61 inch

Q 3. Which one of the following is the Conversion Scientific notation conversion of 0.0001?

- (A) 10^5 (B) 10^{-4} (C) 10^6 (D) 10^{-6}

Q 4. Which one of the following is 10% of 50?

- (A) 5 (B) 7.5 (C) 3 (D) 7

Q 5. Which one of the following is the volume of cylinder, were "r" is radius and "h" is height of the cylinder?

- (A) $V = 2\pi r^2 h$ (B) $V = \pi R^2 h$ (C) $V = \pi r^2 h^2$ (D) $V = \pi r^2 h$

Q 6. If the hypotenuse of a right triangle is 5 inch and one leg is 3 inch, find the measure of the other leg

- (A) 3 inch (B) 4 inch (C) 5 inch (D) 2 inch

Q 7. Which one of the following is the Circumference of circle having radius 1cm ?

- (A) 2π (B) $2\pi^2$ (C) 3π (D) 1

Q 8. Which one of the following is 10% of 50?

- (A) 5 (B) 7.5 (C) 3 (D) 7

Q 9. How many inches are there in 1.5 meter?

- (A) 60.80 inch (B) 58.9 inch (C) 59.05 inch (D) 61 inch

Q 10. Which one of the following is the surface area of MDF board having length 8 feet and width 4 feet?

- (A) 32 square feet (B) 40 square feet (C) 45 square feet (D) 50 square feet



Section – B

- Q.11 Find out the value of $[(10)^2 + (0.001)^2 + (0.001)^2]$ cm in mm.
- Q.12. Find the area of a rectangular shaped lot with a length of 50 yards and a width of 40 yards.
- Q.13 Calculate the volume of cylinder in having diameter 20 cm and height 45 cm.
- Q.14 Nitin constructed an Almira in 3000 Rs and sold it with 10% loss, calculate selling price of Almira.

Section – C

- Q 15. A broker purchased a bench in 5600 Rs and sold it with 15% profit. find out the selling price, if broker wants to earn double of its profit by keeping selling price same what should be the purchasing price.
- Q16.If you deposit Rs.4000 into an account paying 6% annual interest compounded quarterly, how much money will be in the account after 5 years.
- Q 17. You want to put down hardwood floors in your living room that is roughly 18 feet by 16 feet. If the cost of the hardwood flooring is \$5.00 per square foot, find the approximate cost not including labor to put down hardwood flooring in your living room?
- Q 18. A wooden product outlet purchased a dining table in 15000 Rs and sold it with 25% loss. find out the selling price, if wooden product outlet wants to earn 20% profit by keeping selling price same, what should be the purchasing price for dining table.



School of Woodworking Skills
Session: 2019-20 (Summer Semester)
B. Voc. Program, I Semester,
End-Sem. Examination

Sch

Course Code: GEN1104

Time: 2 Hour

Course Name: Elementary Mathematics

Max. Marks: 50

Instructions:

1. Answer all questions from section A, each question carries one mark.
2. Answer all questions from section B, each question carries two marks.
3. Answer all question from section C, each question carries three marks.

Section – A

Q 1 Which one of the following is the value of $10/10^5$?

- (A) 0.01 (B) 0.001 (C) 0.0001 (D) None of these C

Q 2. How many inches are there in 3 meter?

- (A) 60.80 inch (B) 117.8 inch (C) 59.05 inch (D) 61 inch B

Q 3. Which one of the following is the Conversion Scientific notation conversion of 0.0001?

- (A) 10^5 (B) 10^{-4} (C) 10^6 (D) 10^{-6} B

Q 4. Which one of the following is 10% of 50?

- (A) 5 (B) 7.5 (C) 3 (D) 7 A

Q 5. Which one of the following is the volume of cylinder, were "r" is radius and "h" is height of the cylinder?

- (A) $V = 2\pi r^2 h$ (B) $V = \pi R^2 h$ (C) $V = \pi r^2 h^2$ (D) $V = \pi r^2 h$ D

Q 6. If the hypotenuse of a right triangle is 5 inch and one leg is 3 inch, find the measure of the other leg

- (A) 3 inch (B) 4 inch (C) 5 inch (D) 2 inch B

Q 7. Which one of the following is the Circumference of circle having radius 1 cm ?

- (A) 2π (B) $2\pi^2$ (C) 3π (D) 1 A

Q 8. Which one of the following is 10% of 50?

- (A) 5 (B) 7.5 (C) 3 (D) 7 A

Q 9. How many inches are there in 1.5 meter?

- (A) 60.80 inch (B) 58.9 inch (C) 59.05 inch (D) 61 inch C

Q 10. Which one of the following is the surface area of MDF board having length 8 feet and width 4 feet?

- (A) 32 square feet (B) 40 square feet (C) 45 square feet (D) 50 square feet A



Section - B

Q.11 Find out the value of $[(10)^2 + (0.001)^2 + (0.001)^2]$ cm in mm.

$$\left[100 + \left(\frac{1}{1000} \right)^2 + \left(\frac{1}{1000} \right)^2 \right]$$

for mm multiply with 100

$$1000^2 + 100 + 100 =$$

Q.12. Find the area of a rectangular shaped lot with a length of 50 yards and a width of 40 yards.

$$\begin{aligned} \text{area} &= L \times W \\ &= 50 \times 40 \\ &= 2000 \text{ (Yard)}^2 \end{aligned}$$

Q.13 Calculate the volume of cylinder in having diameter 20 cm and height 45 cm.

$$\begin{aligned} V &= \pi r^2 h \\ &= \frac{22}{7} \times 20 \times 20 \times 45 \\ &= 56571.42 \text{ (cm)}^3 \end{aligned}$$

Q.14 Nitin constructed an Almira in 3000 Rs and sold it with 10% loss, calculate selling price of Almira.

$$\begin{aligned} S.P. &= P.P. - \text{Loss} \\ &= 3000 - \frac{3000 \times 10}{100} \\ &= 2700 \text{ Rs.} \end{aligned}$$



BHARTIYA SKILL DEVELOPMENT UNIVERSITY

Section - C

Q 15. A broker purchased a bench in 5600 Rs and sold it with 15% profit. find out the selling price, if broker wants to earn double of its profit by keeping selling price same what should be the purchasing price.

$$P.P = 5600$$

$$S.L = 5600 + 5600 \times \frac{15}{100} \\ = 5600 + 840 = 6440 \text{ Rs}$$

$$S.L = P.P + \text{Profit}$$

$$6440 - 1680 = 4760 \text{ Rs}$$

Q16. If you deposit Rs.4000 into an account paying 6% annual interest compounded quarterly, how much money will be in the account after 5 years.

$$F.V = 4000 \left(1 + \frac{0.06}{4} \right)^{4(5)}$$

$$F.V = 4000 \left(\frac{4 + 0.06}{4} \right)^{20}$$

$$F.V =$$

Q 17. You want to put down hardwood floors in your living room that is roughly 18 feet by 16 feet. If the cost of the hardwood flooring is \$5.00 per square foot, find the approximate cost not including labor to put down hardwood flooring in your living room?

$$\text{Floor area} = L \times W$$

$$= 18 \times 16 = 288 \text{ (feet)}^2$$

$$\text{Total cost} = 288 \times 5 = 1440 \text{ \$}$$

Q 18. A wooden product outlet purchased a dining table in 15000 Rs and sold it with 25% loss. find out the selling price, if wooden product outlet wants to earn 20% profit by keeping selling price same, what should be the purchasing price for dining table.

$$P.P = 15000$$

$$S.L = 15000 + 15000 \times 0.25 \\ 15000 + 3750 = 18750$$

$$S.L = P.P + \text{Profit}$$

$$18750 = 7500 + 11250 \text{ Rs.}$$

The first part of the document discusses the importance of maintaining accurate records of all transactions. It emphasizes that every entry should be supported by a valid receipt or invoice. This ensures transparency and allows for easy verification of the data.

In the second section, the author outlines the various methods used to collect and analyze the data. This includes both primary and secondary data collection techniques. The analysis focuses on identifying trends and patterns over time, which is crucial for making informed decisions.

The third section provides a detailed breakdown of the results. It shows that there has been a significant increase in sales volume, particularly in the online channel. This is attributed to the implementation of the new marketing strategy and the improved user experience on the website.

Finally, the document concludes with a set of recommendations for future actions. It suggests continuing to invest in digital marketing and exploring new product lines to further drive growth. Regular monitoring and reporting will be essential to track the success of these initiatives.



School of WoodWorking Skills

Session: 2019-20 (Summer Semester)

B. Voc. Program, I Semester,

End-Sem. Examination

Course Code: SCS1105

Time: 2 Hour

Course Name: Carpenter Materials

Max. Marks: 50

Instructions:

1. Answer all questions from section A, each question carries one mark.
2. Answer all questions from section B, each question carries four marks.
3. Answer all question from section C, each question carries six marks.

Section – A

Q.1. Which one of the followings is a part of wood structure?

- (a) leaves (b) root
(c) Pith (d) branches

Q.2. Which one of the following is most outer part in wood?

- (a) Annual ring (b) Bark
(c) Pith (d) Heart wood

Q.3. Which one of the following is not a process for seasoning in wood?

- (a) Natural Seasoning (b) Chemical Seasoning
(c) Paint Seasoning (d) Artificial Seasoning

Q.4. Which one of the followings is a wood defect as shown in image?

- (a) Twist (b) cup
(c) Bow (d) Honey combing



Q.5. Which one of the following is natural defect in wood?

- (a) Case hardening (b) Twisted fibers
(c) Dry rot (d) Wet rot

Q.6. Which one of the following is range of density of soft wood panel?

- (a) 200-400 (b) 400-600
(c) 800-900 (d) None of these

Q.7. Which one of the followings is an Aspect ratio used in wood panel?

- (a) Length/Area (b) Area/Thickness
(c) Length/Thickness (d) Thickness/Length

Q.8 Which one of the followings is not a standard size of Fiber board?

- (a) 4*8 feet (b) 6*8 feet
(c) 5*6 feet (d) 4*7 feet

Q.9. Which one of the followings raw material is used for MDF?

- (a) Fiber (b) Wooden strips
(c) Particles (d) Ply



Q.10. Which one of the following is not a type of wood panels?

- (a) Particle board (b) Ply board
(c) MDF (d) Solid wood board

Section – B

- Q 11. Discuss Kiln seasoning process with its various parameters.
Q.12. Differentiate between hard wood and soft wood based on their wood properties.
Q.13 What do you understand by seasoning defects? Explain Bow, Cup, Check, Split, Twist, Honey Combing defects in natural wood with suitable diagram.
Q14 Discuss various types of adhesives used for panel production.

Section – C

- Q.15 What do you understand by veneer, Explain its various types used in furniture industry.
Q 16 Differentiate between Ply board and MDF board.
Q.17. What do you understand by metal alloy? Explain the application of metals in furniture industry with their advantage and disadvantages?
Q.18. What do you mean by OSB? Explain raw material used for Oriented Strand Board?



School of Woodworking Skills

Session: 2019-20 (Summer Semester)

B. Voc. Program, I Semester,

End-Sem. Examination

Course Code: SCS1105

Time: 2 Hour

Course Name: Carpenter Materials

Max. Marks: 50

Instructions:

1. Answer all questions from section A, each question carries one mark.
2. Answer all questions from section B, each question carries two marks.
3. Answer all question from section C, each question carries three marks.

Section – A

Q.1. Which one of the followings is a part of wood structure?

- (a) leaves (b) root A
(c) Pith (d) branches

Q.2. Which one of the following is most outer part in wood?

- (a) Annual ring (b) Bark B
(c) Pith (d) Heart wood

Q.3. Which one of the following is not a process for seasoning in wood?

- (a) Natural Seasoning (b) Chemical Seasoning C
(c) Paint Seasoning (d) Artificial Seasoning

Q.4. Which one of the followings is a wood defect as shown in image?

- (a) Twist (b) cup
(c) Bow (d) Honey combing D

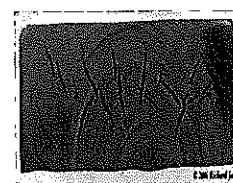

Q.5. Which one of the following is natural defect in wood?

- (a) Case hardening (b) Twisted fibers B
(c) Dry rot (d)Wet rot

Q.6. Which one of the following is range of density of soft wood panel?

- (a) 200-400 (b) 400-600
(c) 800-900 (d) None of these B

Q.7. Which one of the followings is an Aspect ratio used in wood panel?

- (a) Length/Area (b) Area/Thickness
(c) Length/Thickness (d)Thickness/Length C

Q.8 Which one of the followings is not a standard size of Fiber board?

- (a) 4*8 feet (b) 6*8 feet
(c) 5*6 feet (d) 4*7 feet C



BHARTIYA SKILL DEVELOPMENT UNIVERSITY

Q.9. Which one of the followings raw material is used for MDF?

- (a) Fiber
- (b) Wooden strips
- (c) Particles
- (d) Ply

A

Q.10. Which one of the following is not a type of wood panels?

- (a) Particle board
- (b) Ply board
- (c) MDF
- (d) Solid wood board

D

Section – B

Q 11. Discuss Kiln seasoning process with its various parameters.

Kiln Seasoning: - The timber is seasoned under controlled temperature and humidity conditions with proper circulation and ventilation system. The rise in temperature should be such that the timber retains the original strength and elastic properties. The required humidity level is maintained to avoid warping and cracking. The drying of timber at uniform rate is well maintained by circulating hot air by fans and a certain amount of steam is added in order to retain correct humidity. The ventilation is provided to avoid overheating and excessive humidity. The timber inside the chamber, on trolley is kept under controlled conditions for about fortnight or depending upon the initial water content and required moisture level. The quality of wood is inferior as compared to the one seasoned by natural seasoned methods.

Q.12. Differentiate between hard wood and soft wood based on their wood properties.

Soft wood	Hard wood
It is resinous wood having a fragrant smell and regular texture.	It is non-resinous wood containing fairly good amount of acid.
Straight fiber and good texture.	Fibers are quite close and compact.
Light in color and weight.	Dark in color and heavy in weight
annual rings are distinct	Annual rings are not distinct
Good tensile strength and weak shear strength	Good tensile as well as shear strength
Get split quickly	Does not split quickly
Weaker and less durable	stronger and more durable
Catch fire soon cannot withstand high temperature.	It has an added advantage in its refractoriness.
It is easy to be worked	It is difficult to be worked.

Q.13 What do you understand by seasoning defects, explain Bow, Cup, Check, Split, Twist, Honey Combing defects in natural wood with suitable diagram.

Ans. 1. Bow: -this defect is indicated by curvature formed in direction of length of timber.

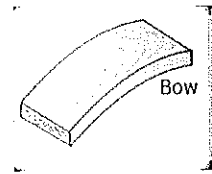

2. Cup: -this defect is indicated by curvature formed in transverse direction of timber

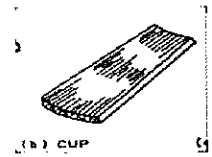

3. check: -a crack which separates fibers of wood. it does not extend from one end to the other.

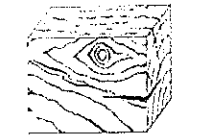

4. Split: -when the extends from one end to other, it is known as a split.

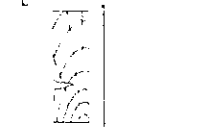

5. Twist: - when a piece of timber has spirally distorted along its length, it is known as a twist.

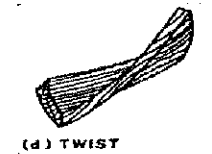

6. Honey-combing: - due to stress developed during drying, various radial and circular cracks develop in the interior portion of timber



Q14 Discuss various types of adhesives used for panel production.

Three types of wood adhesives are available:

Type-I exhibits some waterproof properties.

Type-II will perform better in exterior conditions. These adhesives generally have a longer open time and can bond at colder temperatures. Both types I and II can be used for exterior applications, such as outdoor furniture and trim.

Type-III is not water resistant and is designed for interior use only. It is good for interior woodwork and trim projects.

Section – C

Q.15 What do you understand by veneer, explain its various types used in furniture industry.

veneer is a thin sheet of wood, which is separated from a log by peeling, slicing or sawing. From what thickness a veneer is to be named as such, is not defined. defines nominal thicknesses for veneers made from different species of wood. they are generally between 0.5 mm and 0.6 mm. veneers of this thickness are also called standard veneer. other veneer thicknesses are also produced, depending on their intended use, which are called micro or thick veneers according to their thickness. Micro-veneers are very thin, translucent veneers between 0.1 mm and 0.3 mm thick. Their extreme thinness makes them susceptible to



BHARTIYA SKILL DEVELOPMENT UNIVERSITY

cracking, which requires particular care when they are used. thick veneer is the name given to veneers that are between 0.9 mm and 2.5 mm thick. There is no fluent transition between individual veneer thicknesses. Veneers are always produced with defined thicknesses, e.g. as 0.55 mm, 1.5 mm and 2.5 mm thick veneers. However, these thicknesses vary from wood species to wood species.

Veneers are thin sheets of wood that are sliced from a log and used for decoration or construction (as plywood). Today, special cutting equipment can produce large decorative "leaves" less than 1/64 in (0.5 mm) thick. Traditionally, however, veneers were produced by carefully sawing logs into thin layers about 1/8 in (3 mm) thick. Such saw-cut veneers are still made today, and are largely used for antique restoration.

Types of veneers

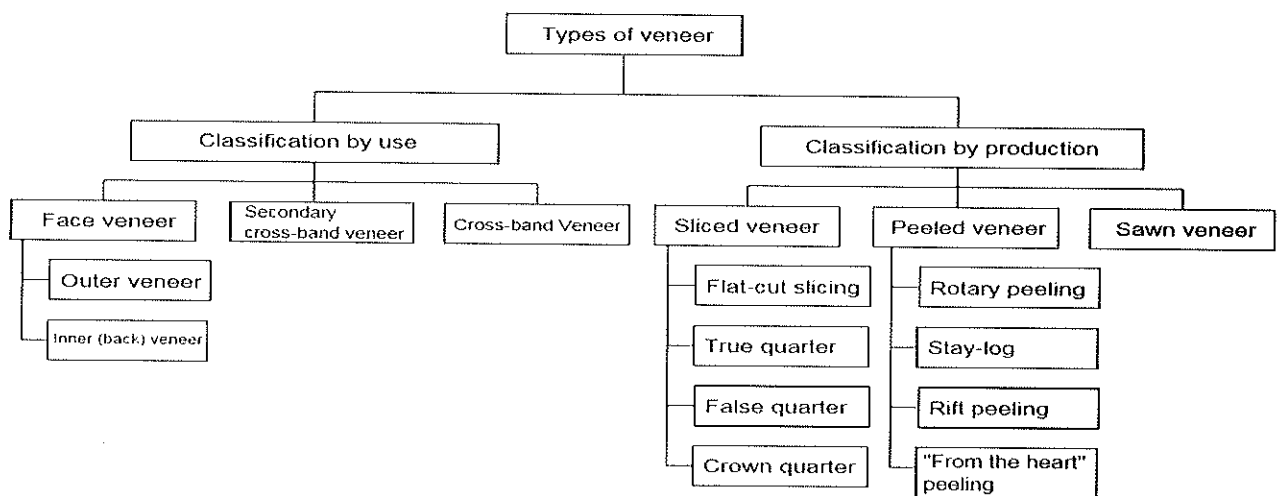

Q 16 Differentiate between Ply board and MDF board.

MDF stands for medium-density fiberboard, which is an engineered wood composite made up of wood fibers. Because the MDF is composed of small wood fibers, there is no visible wood grain, rings, or knots. The making of the composite uses the fibers, glue, and heat to create a tight bonding board. Both softwood and hardwood are used to manufacture MDF. Generally denser than plywood, this composition creates a stronger material for building. We use a veneer sealant to prevent water damage. Two types of fiberboard are moisture resistant (which is typically blue) and fire retardant.

Plywood is an engineered wood product made up of sheets of wood veneer. The wood veneer boards are pressed and bonded together to create one solid piece. This manufacturing process is called cross-graining and it reduces shrinkage and expansion while improving panel strength consistency. Different grades of plywood are used for different purposes. Plywood grades are affected by many variables including the type of wood ply, thickness, adhesive, and manufacturing/compaction process.



BHARTIYA SKILL DEVELOPMENT UNIVERSITY

Q.17. What do you understand by metal alloy, explain the application of metals in furniture industry with their advantage and disadvantages.

Metals and their Alloys are now used second only to wood in the manufacture of furniture. They are found to be stronger and lighter than wood. They withstand heat and dry weather better; can be moulded into almost any form or shape and can result in more modernistic furniture. They are rigid and have a characteristic luster (shine) which makes them both useful and decorative. Metals are both malleable (capable of being beaten into shape or rolled into sheets) and ductile (capable of being drawn into wires of varying thickness). They can be cast into moulds to produce solid shapes. Other methods of working with metals include forging (hammering into shape), welding (joining metal pieces with heat) and drawing (making into thin long wire-like pieces).

Most metals are used in the form of alloys. The commonest amongst these are aluminium alloys, brass and stainless steel. An alloy is an intimate blend of two or more metals, a solid mixture in which the metals are not chemically combined. The forming of alloys adds to the strength and hardness of the metal.

Metal furniture is quite satisfactory in many respects. Tubular steel or aluminium furniture is now commonly used. The former is often found in offices as chairs, tables. Shelves, cupboards and filing cabinets. It is durable, long-lasting and neat.

Tubular steel is also used to make folding chairs. Barring repainting and greasing of joints little maintenance is required. These chairs are sturdy and find wide use.

Advantages:

1. Strong and durable
2. Suitable for indoor and outdoor use. It can be easily molded or shaped.
3. Joining by bolts rivet or welding is secured and sturdy
4. All furniture can with stand weather conditions. It is easily washed with soap and light in weight

Disadvantages:

Surface finish of metal some time chipped off and occasionally they are difficult to repair or replace.

Q.18. What do you mean by OSB, explain raw material used for Oriented Strand Board

Oriented strand board (OSB), also known as flakeboard, sterling board is a type of engineered wood similar to particle board, formed by adding adhesives and then compressing layers of wood strands (flakes) in specific orientations. It was invented by Armin Elmendorf in California in 1963.[1] OSB may have a rough and variegated surface with the individual strips of around 2.5 cm × 15 cm (1.0 by 5.9 inches), lying unevenly across each other and comes in a variety of types and thicknesses.

Oriented strand board is manufactured in wide mats from cross-oriented layers of thin, rectangular wooden strips compressed and bonded together with wax and synthetic resin adhesives (95% wood, 5% wax and resin. The adhesive resins types used include : Urea-



BHARTIYA SKILL DEVELOPMENT UNIVERSITY

formaldehyde The layers are created by shredding the wood into strips, which are sifted and then oriented on a belt or wire cauls. The mat is made in a forming line. Wood strips on the external layers are aligned to the panel's strength axis, while internal layers are perpendicular. The number of layers placed is determined partly by the thickness of the panel but is limited by the equipment installed at the manufacturing site. Individual layers can also vary in thickness to give different finished panel thicknesses (typically, a 15 mm (0.6 in) layer will produce a 15 cm (5.91 in) panel thickness. The mat is placed in a thermal press to compress the flakes and bond them by heat activation and curing of the resin that has been coated on the flakes. Individual panels are then cut from the mats into finished sizes.

Types of OSB

- o OSB/0 – No added formaldehyde
- o OSB/1 – General purpose boards and boards for interior fitments (including furniture) for use in dry conditions
- o OSB/2 – Load-bearing boards for use in dry conditions
- o OSB/3 – Load-bearing boards for use in humid conditions
- o OSB/4 – Heavy-duty load-bearing boards for use in humid conditions



School of Woodworking Skills
Session: 2019-20 (Summer Semester)
B. Voc. Program, I Semester,
End-Sem. Examination

7/1/20

2:00-4:00

Course Code: SCS1106

Time: 2 Hour

Course Name: Hand Drawing

Max. Marks: 50





Instructions:

1. Answer all questions from section A, each question carries one mark.
2. Answer all questions from section B, each question carries four marks.
3. Answer all question from section C, each question carries six marks.

Answer Key?

Section – A

Q.1. Which one of the following indicates a Dash line?

- (a)  (b) 
- (c)  (d) 

Q.2. How many maximum units can be calculated in Diagonal scale?

- (a) 1 (b) 2
- (c) 3 (d) 4

Q 3. Original dimension of the object is 200 mm and it is in drawing of 400. What will be the scale ratio?

- (A) 1:1 (B) 1:2 (C) 2:1 (D) None of these

Q 4. Which one of the following dimensions is used for information block?

- (A) 100*60mm (B) 120*60mm (C) 150*40mm (D) 150*60mm

Q 5. Which one of the following scale is used to measure angle?

- (A) Scale of chord (B) Vernier caliper (C) plain scale (D) Diagonal scale

Q.6 Which one of the following projection angle methods is not used in carpentry drawing?

- (a) First angle (b) Fourth angle
- (c) third angle (d) None of these

Q.7. Which one of the following angle of projections follows sequence of Observer - plan of projection – object?

- (a) First angle of projection (b) Second angle of projection
- (C) third angle of projection (d) Fourth angle of projection

Q 8. Which one of the following section method is used for cutting ¼ part?

- (A) object section (B) half section (C) full section (D) off cut



BHARTIYA SKILL DEVELOPMENT UNIVERSITY

Q 9. Which one of the following angle of projection follows sequence of Observer – object-plan of projection?

- (A) First angle of projection (B) Second angle of projection
(C) third angle of projection (D) Fourth angle of projection

Q 10. Which one of the following section method is used for cutting at center line?

- (A) object section (B) half section (C) full section (D) off cut

Section – B

Q 11. Explain the importance of thick and thin lines, discuss various types of thick lines and thin lines used in Hand drawing.

Q.12. Discuss various types of projection views used in drawing with examples.

Q 13 What is Offset Sectional View? Explain its purpose to use in drawing.

Q 14. Discuss various Drawing equipment used in carpentry drawing.

Section – C

Q 15. Differentiate between half section view and full section view.

Q 16. What is projection of points? Draw points (1,4), (3,6), (-4,5) on coordinate axis, explain the importance of hand drawing in woodworking industries.

Q.17. Discuss various types of drawing lines used in carpentry drawing.

Q. 18. What do you understand by Representative Fraction? Explain various types of scales used in hand drawing with suitable example and neat sketch?



School of Woodworking Skills
Session: 2019-20 (Summer Semester)
B. Voc. Program, I Semester,
End-Sem. Examination

Course Code: SCS1106

Time: 2 Hour

Course Name: Hand Drawing





Max. Marks: 50

Instructions:

1. Answer all questions from section A, each question carries one mark.
2. Answer all questions from section B, each question carries four marks.
3. Answer all question from section C, each question carries six marks.

Section – A

Q.1. Which one of the following indicates a Dash line?

- (a)  (b) 
- (c)  (d) 

B

Q.2. How many maximum units can be calculated in Diagonal scale?

- (a) 1 (b) 2 (c) 3 (d) 4

Q 3. Original dimension of the object is 200 mm and it is in drawing of 400. What will be the scale ratio?

- (A) 1:1 (B) 1:2 (C) 2:1 (D) None of these

Q 4. Which one of the following dimensions is used for information block?

- (A) 100*60mm (B) 120*60mm (C) 150*40mm (D) 150*60mm

Q 5. Which one of the following scale is used to measure angle?

- (A) Scale of chord (B) Vernier caliper (C) plain scale (D) Diagonal scale

Q.6 Which one of the following projection angle methods is not used in carpentry drawing?

- (a) First angle (b) Fourth angle
(c) third angle (d) None of these

Q.7. Which one of the following angle of projections follows sequence of Observer - plan of projection – object?

- (a) First angle of projection (b) Second angle of projection
(C) third angle of projection (d) Fourth angle of projection

Q 8. Which one of the following section method is used for cutting ¼ part?

- (A) object section (B) half section (C) full section (D) off cut



BHARTIYA SKILL DEVELOPMENT UNIVERSITY

Q 9. Which one of the following angle of projection follows sequence of Observer – object-plan of projection?

- (A) First angle of projection (B) Second angle of projection
(C) third angle of projection (D) Fourth angle of projection (A)

Q 10. Which one of the following section method is used for cutting at center line?

- (A) object section (B) half section (C) full section (D) off cut (c)

Section – B

Q 11. Explain the importance of thick and thin lines, discuss various types of thick lines and Thin lines used in Hand drawing.

1. Continuous Thick line: This line is used for visible out line and visible Edges
2. Continuous thin or straight curve line: This line is used for Imaginary lines of intersection, dimension line, projection line, leader line, hatching line, short center line.
3. Continuous thin freehand: This line is used for limits of partial or interrupted views and section.
4. Dashed thick line: This line is used for Hidden outline and hidden edges.
5. Dashed thin line: This line is used for hidden out line and hidden edges.
6. Chain thin: This line is used for center lines and lines of symmetry.

Q.12. Discuss various types of projection views used in drawing with examples.

Ans. Top view, Front view, side view.

Q 13 What is Offset Sectional View, explain its purpose to use in drawing

When specific features of an object that need highlighting are not located on the straight line of the cutting plane, an irregular-shaped cutting plane is imagined cutting the object, revealing the desired components. This is called an "offset view," and is effective on complex objects. The bends in the imaginary cutting pane are always 90 degrees.

Q 14. Discuss various Drawing equipment used in carpentry drawing.

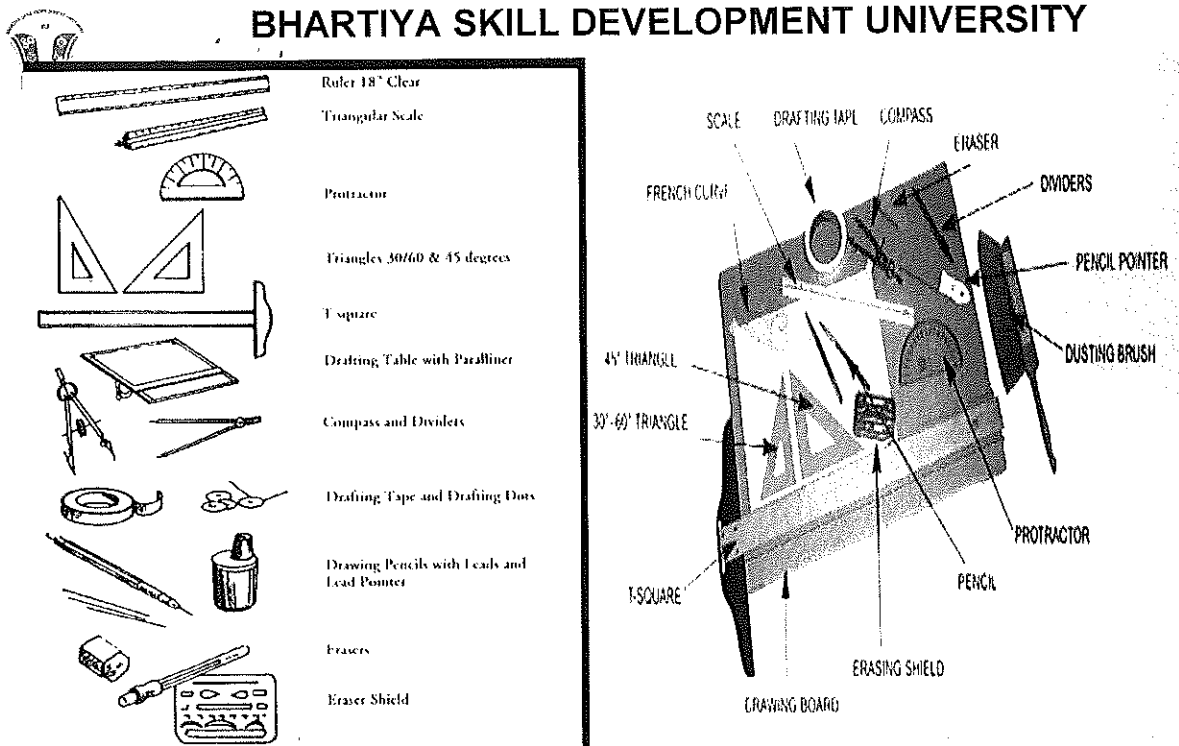

Section – C

Q 15. Differentiate between half section view and full section view.

Ans. In full section view cut section is done across center line and in half section view cut section is done across quarter part.

2. In full section cutting plane passes through the entire object and in half section cut through only half of the object.
3. half section view is effective only on symmetrical object and full section view is effective on non-symmetrical object.
4. in half section internal and external construction is shown in a same drawing and in full section internal and external construction are shown in different drawing.











Q 16. What is projection of points? Draw points (1,4), (3,6), (-4,5) on coordinate axis, explain the importance of hand drawing in woodworking industries.

Importance of hand drawing.

1. To know visualization of product.
2. To have details of joints.
3. Product reality and actual view
4. Product quality
5. To check error in product

Q.17. Discuss various types of drawing lines used in carpentry drawing.



Line	Description	General Application
A	 Continuous thick	A1 Visible outlines. A2 Visible edges.
B	 Continuous thin (straight or curved)	B1 Imaginary lines of intersection. B2 Dimension lines. B3 Projection lines. B4 Leader lines. B5 Hatching lines. B6 Outlines of revolved sections in place. B7 Short centre lines
C	 Continuous thin free hand	C1 Limits of partial or interrupted views and sections. If the limit is not a chain thin.
D	 Continuous thin (straight) with zigzags	D1 Long break line
E	 Dashed thick	E1 Hidden outlines. E2 Hidden edges.
F	 Dashed thin	F1 Hidden outlines. F2 Hidden edges.
G	 Chain thin	G1 Center lines. G2 Lines of symmetry. G3 Trajectories
H	 Chain thin, thick at ends and changes of direction	H1 Cutting planes.
J	 Chain thick	J1 Indication of lines or surfaces to which a special requirement applies
K	 Chain thin double dashed	K1 Outlines of adjacent parts. K1 Alternative or extreme position of movable parts. K3 Centroidal lines. K4 Initial outlines prior to forming K5 Parts situated in front of the cutting plane

Q. 18. What do you understand by Representative Fraction, explain various types of scales used in hand drawing with suitable example and neat sketch?

Representative Fraction: - (RF) = 1/100 (less than one) i.e. the ratio between the size of the drawing and the object.

1. Plain scale: A scale which is used to measure maximum two units and minimum one.
2. Diagonal scale: A scale which is used to measure maximum 3 units and minimum two units.
3. Scale of chord: It is used to measured angle on large field area were protector is not possible to measure angle.