



BHARTIYA SKILL DEVELOPMENT UNIVERSITY

Registration No.:

Set – A

School of Woodworking Skills
Session: 2021-22 (Summer Semester)
B. Voc., 1st Semester,
End-Sem. Examination

Course Code: SCS1104

Time: 2 Hours

Course Name: Assembly and Fittings

Max. Marks: 50

Instruction: (if any)

Section – A

10X01 = 10 Marks

Q.1 Which one of the following is the example of joint where no extra connector is required for joining?

- (a) Biscuit joint (b) Dowel joint
(c) Lap joint (d) None of them

Q.2 Which one of the following is the example of joint where extra connector is required for joining?

- (a) Bridle joint (b) Dovetail joint
(c) Biscuit joint (d) None of them

Q.3 Which one of the following is the example of a joint that can be reassembled?

- (a) Screw (b) Dowel joint
(c) Biscuit joint (d) All of the above

Q.4 Which one of the standard size of Lamello biscuit?

- (a) Ten (b) Zero
(c) Twenty (d) All of them

Q.5 Which one of the following is not the standard size of Lamello biscuit?

- (a) Ten (b) Nine
(c) Twenty (d) Zero

Q.6 Which one of the following machine can be used to cut a miter?

- (a) Circular saw (b) Edge router
(c) Jig Saw (d) Hand router

Q.7 Which one of the following is the shape of Lamello biscuit?

- (a) Circular (b) Elliptical
(c) Oval (d) Rectangle

Q.8 Which one of the following signs is helpful to identify the work pieces in the assembling process?

- (a) Zig Zag lines (b) Triangle
(c) Snack line (d) Cross



BHARTIYA SKILL DEVELOPMENT UNIVERSITY

Q.9 Which one of the following Lamello biscuits can be used for a corner joint with 8 mm MDF boards?

- (a) 20 mm (b) 10 mm
(c) 0 (d) 40 mm

Q.10 Which one of the following wood is used to make Lamello biscuits?

- (a) Steam beach (b) Teak wood
(c) Mango wood (d) Pine wood

Section – B

04X04 = 16 Marks

Q.11 Write a short note on the gluing process of a domino joint in carpenter assembly step by step?

Q.12 What is a dry gluing process? Why do we use this process before gluing?

Q.13 What are the importance of triangle sign?

Q.14 Define the different marking signs and symbols used in carpenter assembly?

Section – C

04X06 = 24 Marks

Q.15 Describe five different types of joinery methods in carpenter assembly?

Q.16 Explain four different types of joints used in carpentry?

Q.17 Describe the procedure of assembly in making a table top as performed in training?

Q.18 Write down the steps to make a bridle joint?



BHARTIYA SKILL DEVELOPMENT UNIVERSITY

Answer key

Set – A

School of Woodworking Skills
Session: 2021-22 (Summer Semester)
B. Voc., 1st Semester,
End-Sem. Examination

Course Code: SCS1104

Time: 2 Hours

Course Name: Assembly and Fittings

Max. Marks: 50

Instruction: (if any)

Section – A

10X01 = 10 Marks

Q.1 Which one of the following is the example of joint where no extra connector is required for joining?

- (a) Biscuit joint (b) Dowel joint
(c) Lap joint (d) None of them (C)

Q.2 Which one of the following is the example of joint where extra connector is required for joining?

- (a) Bridle joint (b) Dovetail joint
(c) Biscuit joint (d) None of them (C)

Q.3 Which one of the following is the example of a joint that can be reassembled?

- (a) Screw (b) Dowel joint
(c) Biscuit joint (d) All of the above (A)

Q.4 Which one of the standard size of Lamello biscuit?

- (a) Ten (b) Zero
(c) Twenty (d) All of them (D)

Q.5 Which one of the following is not the standard size of Lamello biscuit?

- (a) Ten (b) Nine
(c) Twenty (d) Zero (C)

Q.6 Which one of the following machine can be used to cut a miter?

- (a) Circular saw (b) Edge router
(c) Jig Saw (d) Hand router (A)

Q.7 Which one of the following is the shape of Lamello biscuit?

- (a) Circular (b) Elliptical
(c) Oval (d) Rectangle (C)

Q.8 Which one of the following signs is helpful to identify the work pieces in the assembling process?

- (a) Zig Zag lines (b) Triangle
(c) Snack line (d) Cross (B)



BHARTIYA SKILL DEVELOPMENT UNIVERSITY

Q.9 Which one of the following Lamello biscuits can be used for a corner joint with 8 mm MDF boards?

- (a) 20 mm (b) 10 mm
(c) 0 (d) 40 mm (C)

Q.10 Which one of the following wood is used to make Lamello biscuits?

- (a) Steam beach (b) Teak wood
(c) Mango wood (d) Pine wood (A)

Section – B

04X04 = 16 Marks

Q.11 Write a short note on the gluing process of a domino joint in carpenter assembly step by step?

Ans: - Gluing process by using domino in assembly, after making groove in all pieces first we will glue all the domino of the thickness side of the pieces and then we glued all the side pieces on the bottom of the box and will clamp it for 30 to 40 minutes. During the clamping we will use some waste pieces between final pieces and clamp which will prevent final piece to damages and remove all the extra glue from inside of the box with wet cotton.

Q.12 What is a dry gluing process? Why do we use this process before gluing?

Ans: - Process in which we follow whole gluing process without using glue in it is called dry gluing process.

We used this process for following purpose.

- ✓ To check errors in the assembly.
- ✓ To check the positioning of the pieces.
- ✓ To check all availability.

Q.13 What are the importance of triangle sign?

Ans: - Triangles sign is used for assembly purpose. We used this sign as an identification of the part. This triangle making process follows some following points.

- ✓ We always make triangle according to front view of the drawing.
- ✓ This is not possible to make triangle sign on all parts in front view than only we go for top or side view.
- ✓ Triangle sign should always come on the corners of work piece.
- ✓ This is not necessary to complete the triangle sign always.

Q.14 Define the different marking signs and symbols used in carpenter assembly?

Ans: -

- ✓ Wave line: - Wave line show the material will be remove till the wave line.
- ✓ Circle Line: - Circle line show the material will be cut till the center point of the circle.



BHARTIYA SKILL DEVELOPMENT UNIVERSITY

- ✓ Cross line: - Cross line show this material will be remove throughout.
- ✓ Triangle sign: - Triangle sign is used for assembly purpose. We used this sign as an identification of the part. This triangle making process follows some following points.

Section – C

04X06 = 24 Marks

Q.15 Describe five different types of joinery methods in carpenter assembly?

Ans: -

- ✓ Gluing: - In the gluing process by using Lamello in assembly, after making groove in all pieces first we will glue all the biscuits on the thickness side of the pieces and then we glued all the side pieces on the bottom of the box and will clamp it for 3 to 4 hours.
- ✓ Nailing: - In the nailing process we can nail parts together by using different nails.
- ✓ Biscuit joinery: - In biscuit joinery system we can joint to parts together by using domino joints.
- ✓ Domino joinery system: - In the domino joinery system we can joint to parts together by using domino joints.
- ✓ Wooden Dowel: - In the wooden dowel joinery system we can joint to parts together by using wooden dowel and glue.

Q.16 Explain four different types of joints used in carpentry?

Ans: -

- ✓ Bridle joint: - This joint is also called Tenon joint. This joint is where the through mortise is open on one side and forms a fork shapes.
- ✓ Miter joint: - This joint is smaller to butt joint, but both pieces have been belovved (usually at a 45-degree angle).
- ✓ Dovetail joint: - A form of box joint where the finger is locked together by diagonal cuts.
- ✓ Housing joint: - A slot is cut across the grain in one piece for another piece to cut in to.

Q.17 Describe the procedure of assembly in making a table top as performed in training?

Ans: -

- ✓ Drawing reading.
- ✓ According to drawing we will select material.
- ✓ After that we will cut the material by panel saw according to given dimension.
- ✓ Then we make 90 degrees by surface planer machine.
- ✓ Then we will make sizing in thickness and width side by thicknesses machine.
- ✓ Set the material according to give dimension in width.
- ✓ Mark the triangle sign.



BHARTIYA SKILL DEVELOPMENT UNIVERSITY

- ✓ Then we will do Lamello by Lamello machine.
- ✓ Then we will do glue and clamp the material.
- ✓ Leave it with clamp for 45 minutes.
- ✓ After that we will make fixed sizing by panel saw.
- ✓ Then we will do sending by sending costa machine.
- ✓ Then we will do sending by hand sending machine.
- ✓ Then we will make chamfer by edge router machine.
- ✓ After that we will do oiling by teak oil.
- ✓ After 20 minutes we will do polish by dry cloths.

Q.18 Write down the steps to make a bridle joint?

Ans: - Also known as open Tenon, open mortise and Tenon, or tongue and fork joints, this joint is where the through mortise is open on one side and forms a fork shape. The mate has a through Tenon or necked joint. Also used in scarf joints and sometimes sill corner joints in timber framing.



BHARTIYA SKILL DEVELOPMENT UNIVERSITY

Answer key...

School of Woodworking Skills
Session: 2021-22 (Summer Semester)
B. Voc. Program, 1st Semester,
End-Sem. Examination

Course Code: SCS1105

Time: 2 Hours

Course Name: Carpenter Materials (SET A)

Max. Marks: 50

Instruction: All the questions are compulsory.

Section – A

10X01 = 10 Marks

1) Tensile strength is

- a) Strength of fiber
- b) Hardness of wood
- c) Stiffness of wood
- d) None of the above.

2) In HGP laminate, P stands for

- (a) Pressurized
- (b) Post formed
- (c) Preprocessed
- (d) None

3) Linseed oil used for

- (a) Laminate
- (b) Particle board
- (c) Linoleum
- (d) edge material

4) The wooden board stacked on top of one another at regular interval using spacer strip, arrangement used for

- a) Natural drying
- (b) Inventory management
- (c) Materials identification
- (d) stock verification

5) When wood is dried, it releases moisture and changes its shape. This process is called

- (a) Swelling
- (b) Shrinkage
- (c) Seasoning
- (d) None

6) Which of the following is regarded as a modern abrasive?

- (a) Tripoli
- (b) Silicon carbide
- (c) Pumice
- (d) Boron carbide

7) Shear strength of wood depends on

- (a) Sapwood
- (b) Heartwood
- (c) medullary rays
- (d) Lignin and fiber

8) Carborundum is

- (a) Adhesive
- (b) Abrasive
- (c) Resin
- (d) Cleaning agent

9) The layer responsible for transport of nutrient to the core called as

- (a) Core
- (b) Sapwood



BHARTIYA SKILL DEVELOPMENT UNIVERSITY

(c) Cambium

(d) Medullary rays

10) The most suitable wood for Fire resistance behavior

(a) Acacia

(b) Oak

(c) Teak

(d) Plum tree

Section – B

04X04 = 16 Marks

11) Describe in brief the role of tribe in stability and growth of tree.

Answer: *The base layers* If you look at the cross-section of a trunk, you will see that it consists of different zones or layers.

The marrow / marrow tube lies at the center of the trunk and is responsible for the tree growing tall.

The core (the heartwood) lies in the inner part of the trunk. Heritage comes from old wooden cells that store nutrients. Most of the wood you use as a carpenter comes from this part of the tree because heartwood is more resistant than sapwood. Heartwood can be a darker color than sapwood. This varies depending on the type of wood.

The sapwood (sapwood) has the task of transporting water and nutrients from the roots to the leaves. Sapwood is less durable than heartwood. Sapwood can be lighter in color than the heartwood. This varies depending on the type of wood.

The cambium is the growth layer of the tree. It is a thin, sensitive layer. The cambium is responsible for the production of new wood during the growing season of the tree (spring and summer).

The bast is under the bark. It transports the nutrients produced in the leaves into the tree trunk.

The bark is the outermost layer of the tree. Their function is to protect the tree against extreme temperatures, pests and diseases. The bark is called bark together with the bast.

12) Compare the bonded and coated abrasive.

Answer:

Bonded abrasive: A bonded abrasive is composed of an abrasive material contained within a matrix, although very fine aluminium oxide abrasive may comprise sintered material. This matrix is called a binder and is often a clay, a resin, a glass or a rubber. This mixture of binder and abrasive is typically shaped into blocks, sticks, or wheels. The most common abrasive used is aluminium



BHARTIYA SKILL DEVELOPMENT UNIVERSITY

oxide. Also common are silicon carbide, tungsten carbide and garnet. Another examples of bonded abrasive is grinding wheel.

Coated abrasive

A coated abrasive is an abrasive grain bonded to a flexible base like paper, cloth, vulcanised fibre or plastic film. Sand paper is an excellent example. Such abrasives come in various grit sizes, ranging from a very coarse 2mm grain to ultra fine grains of less than a millimetre in diameter. As you can imagine some abrasives are better for certain jobs than others, some are designed for working by hand and others specifically for use with machines like an orbital sander, belt sander or drum sander.

13) Write the difference between density and bulk density.

Answer: - Mass of any substance per unit volume of material is known as density or absolute density of material. It is expressed as "kg/m³". In the case of porous substances, the ratio between mass and volume can vary greatly. the decisive factor is how much material and how much air or gas is in the volume. That is why the term density is used instead of density for such substances. It is expressed as "kg/m³"

14) Explain the term linoleum with its advantages.

Answer: - Linoleum is a material invented a century ago and a pure natural product. It consists of linseed oil, cork flour and resins. The surface is smooth and available in different shades of color. The linseed oil oxidizes at temperatures of 80°C, whereby natural resins are mixed in and the mass is processed into linoleum cement. The linoleum cement is then mixed and kneaded with cork, wood flour. The resulting fine-grained mass is rolled onto the carrier fabric and acquires the desired properties in a maturation process of two to four weeks. With the increasing of environmental concern and the promotion of natural materials, with less environmental impact, linoleum has been increasingly regarded as floor coating option due to its composition of natural materials and their more environment friendly properties, by comparison with other solutions.

Section – C

04X06 = 24 Marks

15) Explain the cell structure and its importance in growth of tree.

Answer:

The size and arrangement of the wooden cells vary depending on the type of wood. The hardness and strength of a type of wood largely depend on how big the wooden cells are and how the wooden cells are arranged next to each other. The wooden cells that form in spring



BHARTIYA SKILL DEVELOPMENT UNIVERSITY

are large, the wood mass is loose and porous, and the cell walls are thin. This is the so-called early wood. In contrast, the late wood, which forms in summer and autumn, consists of much smaller, but thicker-walled cells.

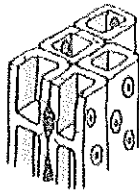
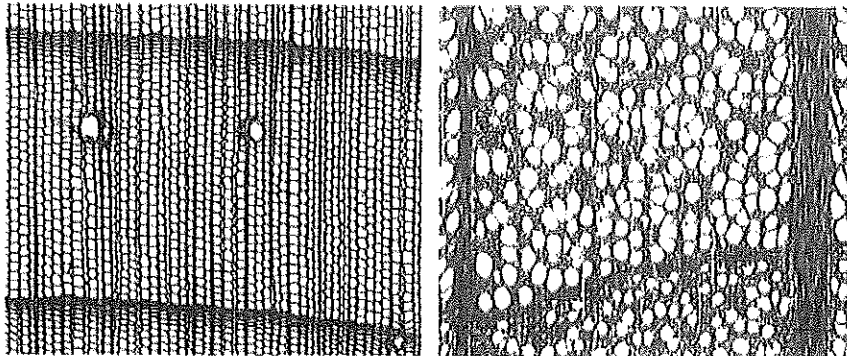

Early wood

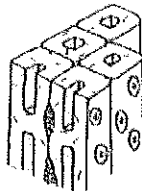

Late wood

16) Explain the criteria for selecting abrasive materials.

Answer:

The selection of a particular abrasive is determined by its action for the type of function to be performed on the material to be processed. The effect of an abrasive material depends on three key characteristics:

- Particle shape.** The shape of an abrasive may be angular, blocky, semi-round or spherical. Angular particles cut and strip away surface material on impact. Spherical particles do not have any cutting edges and are used to pound or peen a surface. Grain shape is important as rounded and angular grains behave differently when they impact a substrate such as steel. Angular, sharp particles produce the greatest cutting action and the deepest profile. Round or semi-round particles will cut much more slowly and will produce a more shallow profile.
- Hardness.** The hardness of an abrasive is measured using the Mohs scale. Harder particles will be more aggressive in removing surface material.
- Particle size.** A larger particle removes material faster and it tends to produce a heavier texture or rougher surface on the base material.

17) Explain the steps for processing veneer.

Answer: Veneer selection

When choosing the veneers, you have to answer various questions:

- Type of wood
- With or without branches
- With or without color core



BHARTIYA SKILL DEVELOPMENT UNIVERSITY

Rift, flader (construction) or semi-rift

Air condition the veneer before cutting it by taking it from the warehouse to the workshop a few days before processing and adapting it to the climate of the workshop.

Veneer cut

Cut the veneer with a veneer saw, a veneer router or a veneer cutting machine. Your goal must be to make the best use of the valuable veneer, to minimize errors and to keep veneer waste within limits.

Veneer composition

Put the individual veneer sheets together. You can do this either with veneer tape, with veneer glue thread on a veneer sewing machine or with a veneer splicing machine that glues veneer

Preparation of carrier material

Chipboard or MDF boards are usually used as the carrier material for veneer. In order to be able to cut the finished veneered panels to the exact size after veneering, you must include a dimensional allowance of 10 mm to 20 mm when cutting the panels. The surfaces of the backing material must be dry, free of dust and grease so that the glue can adhere properly. The backing material must also be flat

18) Explain the characteristics of Laminate.

Answer:

- Attractive aesthetic qualities
- High mechanical strength
- Flexibility
- Dimensional stability
- Durability (impact, wear and graffiti resistance)
- Lightfastness of colour
- Good chemical resistance
- Resistance to the effects of water, steam, heat and frost
- Good fire resistance
- Ease of cleaning
- Hygienic qualities
- Anti-static properties (does not attract dust)
- Ease of installation

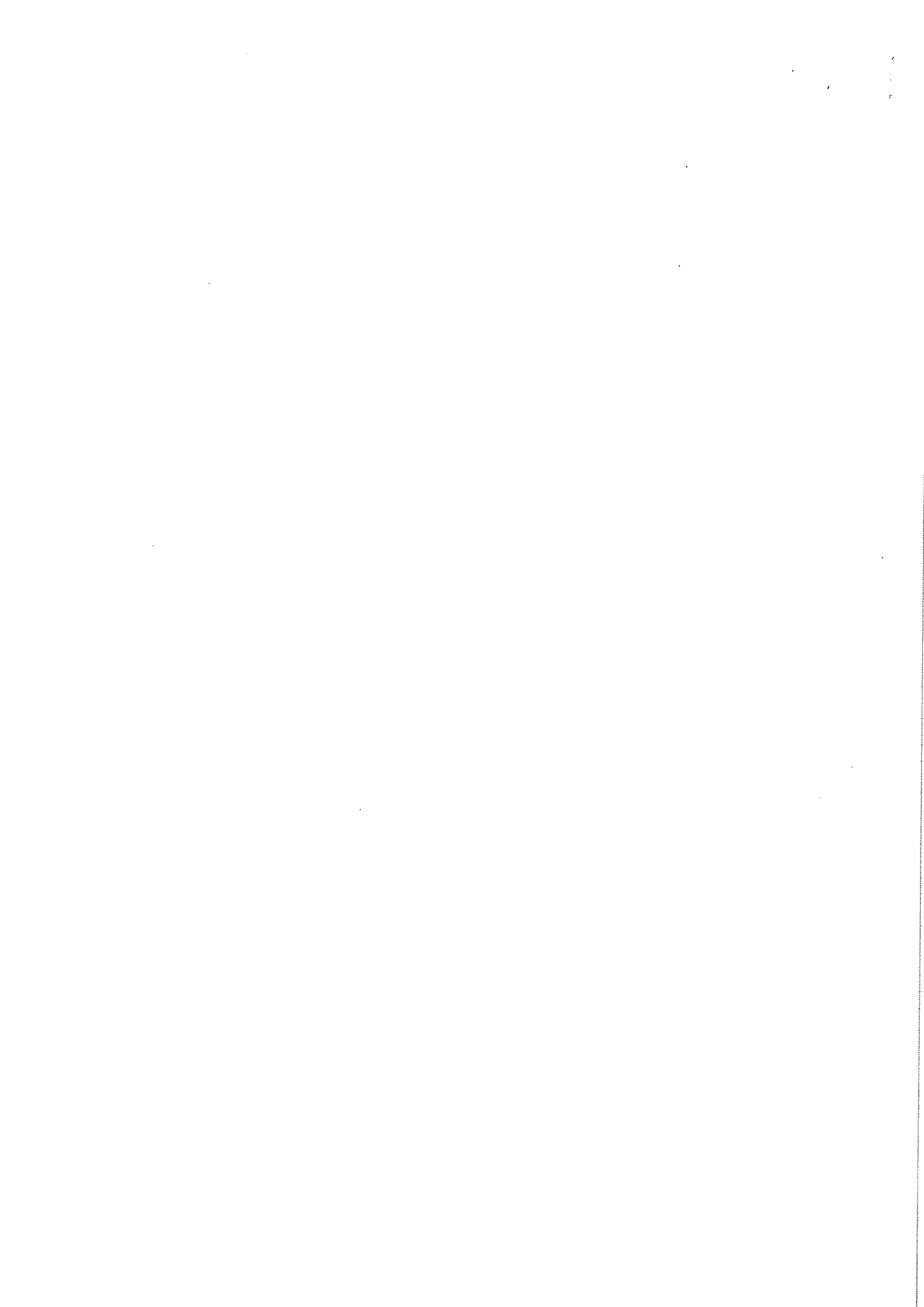



BHARTIYA SKILL DEVELOPMENT UNIVERSITY

Registration No.:

School of Woodworking Skills
Session: 2021-22 (Summer Semester)
B. Voc. Program, 1st Semester,
End-Sem. Examination

Course Code: SCS1105

Time: 2 Hours

Course Name: Carpenter Materials (SET A)

Max. Marks: 50

Instruction: All the questions are compulsory.

Section – A

10X01 = 10 Marks

Q1) Tensile strength is

- a) Strength of fiber (b) Hardness of wood
c) Stiffness of wood (d) None of the above.

Q2) In HGP laminate, P stands for

- (a) Pressurized (b) Post formed
(c) Preprocessed (d) None

Q3) Linseed oil used for

- (a) Laminate (b) Particle board
(c) Linoleum (d) edge material

Q4) The wooden board stacked on top of one another at regular interval using spacer strip, arrangement used for

- a) Natural drying (b) Inventory management
c) Materials identification (d) stock verification

Q5) When wood is dried, it releases moisture and changes its shape. This process is called

- (a) Swelling (b) Shrinkage
(c) Seasoning (d) None

Q6) Which of the following is regarded as a modern abrasive?

- (a) Tripoli (b) Silicon carbide
(c) Pumice (d) Boron carbide

Q7) Shear strength of wood depends on

- (a) Sapwood (b) Heartwood
(c) medullary rays (d) Lignin and fiber

Q8) Carborundum is

- (a) Adhesive (b) Abrasive
(c) Resin (d) Cleaning agent

Q9) The layer responsible for transport of nutrient to the core called as

- (a) Core (b) Sapwood
(c) Cambium (d) Medullary rays

Q10) The most suitable wood for Fire resistance behavior

- (a) Acacia (b) Oak
(c) Teak (d) Plum tree



BHARTIYA SKILL DEVELOPMENT UNIVERSITY

Section – B

04X04 = 16 Marks

- Q11) Describe in brief the role of tracheids in stability and growth of tree.
- Q12) Compare the bonded and coated abrasive.
- Q13) Write the difference between density and bulk density.
- Q14) Explain the term linoleum with its advantages.

Section – C

04X06 = 24 Marks

- Q15) Explain the cell structure and its importance in growth of tree.
- Q16) Explain the criteria for selecting abrasive materials.
- Q17) Explain the steps for processing veneer.
- Q18) Explain the characteristics of Laminate.



School of Woodworking Skills

Session: 2021-22 (Summer Semester)

B. Voc. Program, 1st Semester,

End Sem. Examination

Course Code: SCS1106

Course Name: Hand Drawing

Time: 2 Hour

Max. Marks: 50

Instruction:

- Answer all questions from section A, each question carries one mark.
- Answer all question from section B, each question carries four marks.
- Answer all question from section C, each question carries six marks.

Section A

10X01 = 10 Marks

- Q. 1 Smallest unit of measurement is
(A) Km (B) Meter
(C) Millimeter (D) Decameter Ans. C
- Q. 2 Overlapping occurs in which angle of projection
(A) 4th (B) 1st
(C) 3rd (D) None of these Ans. A
- Q. 3 1 millimeters are equivalent to
(A) 0.1 centimeter (B) 1000 meter
(C) 1 meter (D) None of them Ans. A
- Q. 4 If an object front view and top view drawn both above x-y line then object drawn in which angle of projection.
(A) 2nd (B) 1st
(C) 3rd (D) 4th Ans. B
- Q. 5 What is the significance of continuous thin line in engineering drawing?
(A) Outlines of the object (B) Hidden surface
(C) extension line (D) line of symmetry Ans. C
- Q. 6 In the given option which pencil will be lighter?
(A) H (B) 2H
(C) 2B (D) 3B Ans. B
- Q. 7 Drawing is created in which angle of projection
(A) 2nd (B) 1st



BHARTIYA SKILL DEVELOPMENT UNIVERSITY

- (C) 4th (D) None of these Ans. B
- Q. 8 The Representative factor for enlarging scale is
- (A) Equal to 1 (B) Always greater than 1
(C) A&B Both (D) None of them Ans. B
- Q. 9 An object front view lie below x-y and top view above x-y line object is in which quadrant
- (A) 2nd (B) 1st
(C) 3rd (D) 4th Ans. C
- Q. 10 Which one will be the size for A₀ Sheet in millimeter?
- (A) 420x297 (B) 1189x841
(C) 297x210 (D) 594x841 Ans. B

Section B

04X04 = 16 Marks

- Q. 11 Write short notes on orthographic Projection with proper diagram.

Ans. In parallel projection, all lines of sight are parallel and is schematically represented in figure. The observer is assumed to be stationed at infinite distance from the object.

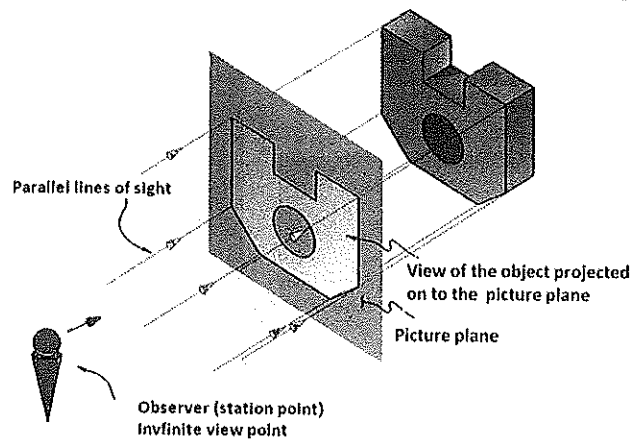

- Q. 12 Write short notes on types of lines used in engineering drawing with application.





Ans. **Lines**

It is one important aspect of technical drawing. Lines are always used to construct meaningful drawings. Various types of lines are used to construct drawing, each line used in some specific sense. Lines are drawn following standard conventions mentioned in BIS

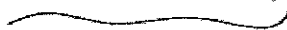
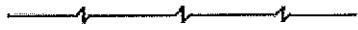
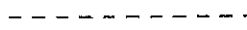
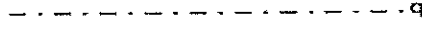

BHARTIYA SKILL DEVELOPMENT UNIVERSITY

(SP46:2003). A line may be curved, straight, continuous, segmented. It may be drawn as thin or thick. A few basic types of lines widely used in drawings are shown in Table Types of lines used in engineering drawing.

Illustration	Application
Thick 	Outlines, visible edges, surface boundaries of objects, margin lines
Continuous thin 	Dimension lines, extension lines, section lines leader or pointer lines, construction lines, boarder lines
Continuous thin wavy 	Short break lines or irregular boundary lines – drawn freehand
Continuous thin with zig-zag 	Long break lines
Short dashes, gap 1, length 3 mm 	Invisible or interior surfaces
Short dashes 	Center lines, locus lines Alternate long and short dashes in a proportion of 6:1,
Long chain thick at end and thin elsewhere 	Cutting plane lines

Q. 13 Draw the 3d diagram of a chair

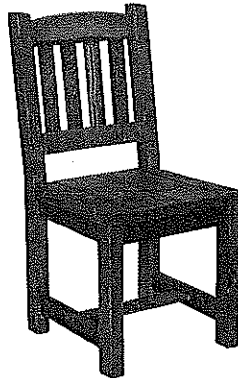

Q. 14 Find out the coordinates of point 1,2,3 in Relative system.



BHARTIYA SKILL DEVELOPMENT UNIVERSITY

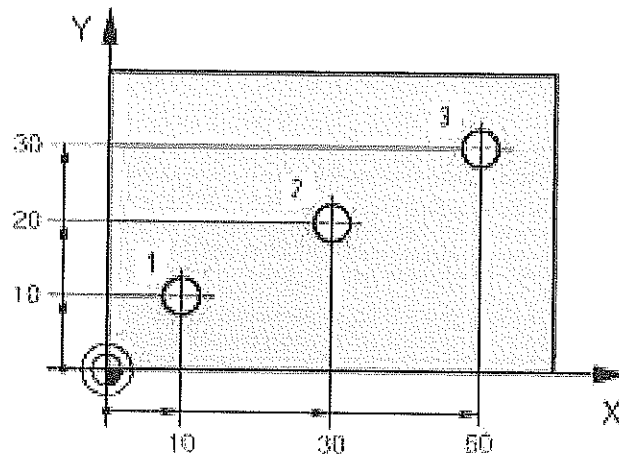

Ans.

Relative system

Hole 1	Hole 2	Hole 3
X = 10 mm	X = 20 mm	X = 20 mm
Y = 10 mm	Y = 10 mm	Y = 10 mm

Section C

04X06 = 24 Marks

Q. 15 Draw the following

- A point is placed 40mm in front of VP and 40 mm below HP.
- A point is placed 30 mm in front of VP and 40 mm above HP.

Ans.

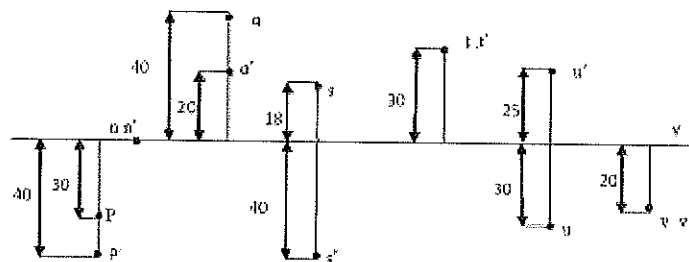

Q. 16 Define any three out of the following

- Nominal Size
- Basic Size



BHARTIYA SKILL DEVELOPMENT UNIVERSITY

- c) Actual Size
- d) Tolerance

Ans.

Nominal size: The nominal size of a dimension is the size specified in the drawing. It is usually given in the drawing as rounded off whole millimeters.

Basic size: The basic size of dimension is the size in relation to which all limits of variations are determined.

Actual size: the actual size of an object measured.

Tolerance : It is the difference between upper and lower limit .

Q. 17 Draw the front, top and right side view of the following Diagram in 1st angle projection?

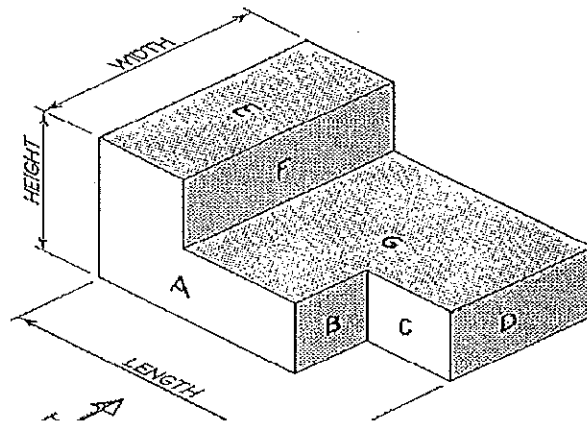

Ans.



BHARTIYA SKILL DEVELOPMENT UNIVERSITY

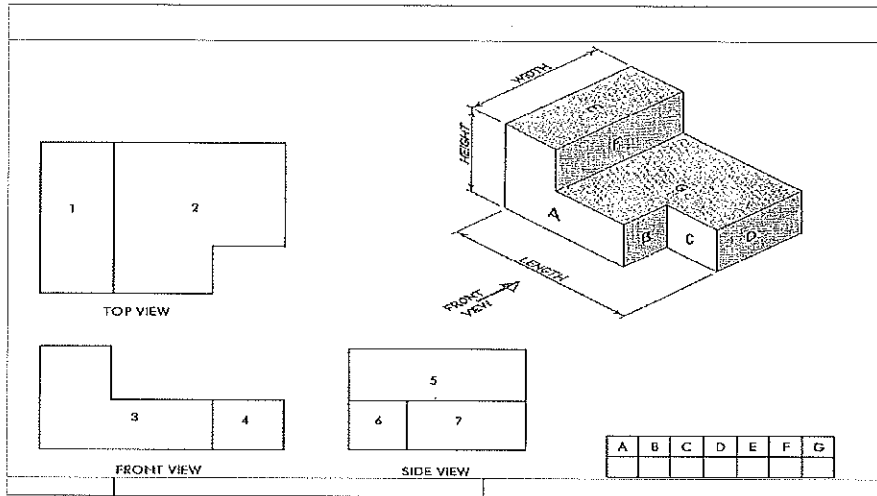

Q. 18 Define Representative factor and its significance in drawing and also calculate the RF of an object of length 10 micron is drawn on a size of 500mm.

Ans. A scale is defined as the ratio of the linear dimensions of the object as represented in a drawing to the actual dimensions of the same.

- Drawings drawn with the same size as the objects are called full sized drawing.
- It is not convenient, always, to draw drawings of the object to its actual size. e.g. Buildings,
- Heavy machines, Bridges, Watches, Electronic devices etc.
- Hence scales are used to prepare drawing at
 - Full size
 - Reduced size
 - Enlarged size

$$\text{Representative Factor (RF)} = \frac{\text{Drawing length of an object}}{\text{Actual length of an object}}$$

Actual length of an object = 10 micron

Drawing length = 500mm

$$Rf = \frac{.500}{10} = 0.5$$