



School of Woodworking Skills
Session: 2020-21 (Summer / Winter Semester)
B. Voc, 3rd Semester,
End-Sem. Examination (Make-up)

Course Code: SCS1304

Time: 3 Hours

Course Name: Carpenter Mathematics

Max. Marks: 100

Instruction: calculator permitted.

Section – A

20X01 = 20 Marks

Q.1 The plane which consists of two number lines that intersect each other at right angle is called:

- (a) Functional plane (b) Cartesian plane (c) Ordinate plane (d) Dimensional plane

Q.2 General notation for cylindrical coordinates system is:

- (a) (x,y,z) (b) (r, θ, ϕ) (c) (r, θ, z) (d) None of these

Q.3 If a share of NV of Rs 10 is selling at Rs 16 then:

- (a) the share is at a premium of Rs 6. (b) discounted at Rs. 6.(c) at par. (d) None of these.

Q.4 Location of the point $(-5, 4)$ and $(-7, -8)$ in cartesian coordinates:

- (a) I, II quadrants (b) III, IV quadrants (c) II, III quadrants (d) II, IV quadrants

Q.5 Amount required for buying 275 shares, Rs 60 shares at a discount of Rs 10.

- (a) 13750/- (b) 12300/- (c) 11400/- (d) 11750/-

Q.6 If a share of NV of Rs 100 is selling at Rs 80 then:

- (a) the share is at a premium of Rs 20. (b) discounted at Rs. 20.(c) at par.(d) None of these.

Q.7 General notation of spherical coordinates system is:

- (a) (x,y,z) (b) (r, θ, z) (c) (r, θ, ϕ) (d) None of these

Q.8 Location of the point $(-10, 4)$ and $(-7, -8)$ in cartesian coordinates:

- (a) I, II quadrants (b) III, IV quadrants (c) II, III quadrants (d) II, IV quadrants

Q.9 Amount required for buying 50 shares, Rs 75 quoted at Rs 71.50.

- (a) 3750/- (b) 3575/- (c) 3475/- (d) 5363/-

Q.10 The conversion of $(4, -1, -8)$ in cylindrical coordinates represented by:

- (a) $(\sqrt{17}, 3.3866, 8)$ (b) $(\sqrt{19}, 4.876, 8)$ (c) $(\sqrt{17}, 8, 3.3866)$ (d) $(\sqrt{17}, -1, 8)$

Q.11 The a relation between x and y if the point (x, y) is equidistant from the points $(7, 1)$ and $(3, 5)$.



BHARTIYA SKILL DEVELOPMENT UNIVERSITY

- (a) $x-y=5$ (b) $x-y=2$ (c) $x+y=2$ (d) $x+y=5$

Q.12 General notation for cartesian coordinates system is:

- (a) (x,y,z) b) (r, θ, ϕ) c) (r, θ, z) d) None of these

Q.13 $9\sec^2 A - 9 \tan^2 A$ is

- a) 1 b) 9 c) 8 d) 0

Q.14 A flooring tile has the shape of a parallelogram whose base is 24 cm and the corresponding height is 10 cm. How many such tiles are required to cover a floor of area 1080 m²?

- a) 15000 b) 30000 c) 45000 d) 12000

Q.15 The lateral surface area of sphere is

- a) $4\pi r^2$ b) $4\pi r$ c) $2\pi r^2$ d) πr^2

Q.16 The property of material by virtue of which it can resist the abrasion and scratches

- a) Ductility b) Hardness c) Malleability d) Stiffness

Q.17 The oak wood has a mass of 134 kg and a volume of 194 dm³ What is the density?

- (a) 1.44 kg/dm³ (b) 0.69 kg/dm³ (c) 0.89 kg/dm³ (d) 1.34 kg/dm³

Q.18 $\operatorname{cosec}(90-A)$ is

- (a) $\sin A$ b) $\tan A$ c) $\sec A$ d) None

Q.19 $\frac{\tan 26^\circ}{\cot 64^\circ} =$

- (a) 2 b) 1 c) 0 d) None

Q.20 The area of a rhombus is 240 cm² and one of the diagonals is 16 cm. The length of another diagonal is

- a) 15 cm b) 30 cm c) 32 cm d) 12 cm

Section – B

06X05 = 30 Marks

(Attempt any 06 questions out of 08 questions)

Q.21 Write short notes on: a) Dry and wet bulb temperature b) tensile and compressive strength.

Q.22 Mukul invests Rs 9000 in a company paying a dividend of 6% per annum when a share of NV Rs 100 stands at Rs 150. What is his annual income? If he sells 50% of his shares when the price rises to Rs 200, what is his gain in this transaction?



Q.23 Show that the points (1, 7), (4, 2), (-1, -1) and (-4, 4) are the vertices of a square.

24) Prove that $\left(\frac{\sin\theta - 2\sin^3\theta}{2\cot^3\theta - \cos\theta}\right) = \tan\theta$

Q.25 Find a relation between x and y such that the point (x, y) is equidistant from the points (7, 1) and (3, 5).

Q.26 Do the points (3, 2), (-2, -3) and (2, 3) form a triangle? If so, name the type of triangle formed.

Q.27 if $3 \cot A = 4$, check whether $\frac{1 - \tan^2 A}{1 + \tan^2 A} = \cos^2 A - \sin^2 A$ or not.

Q.28 Convert the following equation written in Cartesian coordinates into an equation in Cylindrical coordinates.

$$x^3 + 2x^2 - 6z = 4 - 2y^2$$

Section – C

05X10 = 50 Marks

Q.29 Write short notes on: a) Dry and wet bulb temperature b) tensile and compressive strength.

Q.30 Explain the influence of moisture on mechanical properties of wood-based products.

Q.31 Robert bought shares of 6% \$ 100 shares at \$ 120. Adrian bought shares of 8% \$ 20 shares at \$ 30. Whose investment was better?

Q.32 Prove that $\left(\frac{1 + \tan^2 A}{1 + \cot^2 A}\right) = \left(\frac{1 - \tan A}{1 - \cot A}\right)^2 = \tan^2 A$

Q.33 In a building there are 24 cylindrical pillars. The radius of each pillar is 28 cm and height is 4 m. Find the total cost of painting the curved surface area of all pillars at the rate of INR 8 per m².



School of Woodworking Skills

Session: 2020-21 (Summer / Winter Semester)

B. Voc. Program, 3rd Semester,

End-Sem. (Make-up)

Course Code: SCS1304

Time: 3 Hours

Course Name: Carpenter Mathematics

Max. Marks: 100

Instruction: (if any)

Section – A

20X01 = 20 Marks

1) The plane which consists of two number lines that intersect each other at right angle is called:

- (a) Functional plane (b) Cartesian plane (c) Ordinate plane (d) Dimensional plane

Ans: (b)

2) General notation for cylindrical coordinates system is:

- (a) (x, y, z) (b) (r, θ, ϕ) (c) (r, θ, z) (d) None of these

Ans: (c)

3) If a share of NV of Rs 10 is selling at Rs 16 then:

- (a) the share is at a premium of Rs 6. (b) discounted at Rs. 6. (c) at par. (d) None of these.

Ans: (a)

4) Location of the point $(-5, 4)$ and $(-7, -8)$ in cartesian coordinates:

- (a) I, II quadrants (b) III, IV quadrants (c) II, III quadrants (d) II, IV quadrants

Ans: (d)

5) Amount required for buying 275 shares, Rs 60 shares at a discount of Rs 10.

- (a) 13750/- (b) 12300/- (c) 11400/- (d) 11750/-

Ans: (a)

6) If a share of NV of Rs 100 is selling at Rs 80 then:

- (a) the share is at a premium of Rs 20. (b) discounted at Rs. 20. (c) at par. (d) None of these.

Ans: (b)

7) General notation of spherical coordinates system is:

- (a) (x, y, z) (b) (r, θ, z) (c) (r, θ, ϕ) (d) None of these

Ans: (c)

8) Location of the point $(-10, 4)$ and $(-7, -8)$ in cartesian coordinates:

- (a) I, II quadrants (b) III, IV quadrants (c) II, III quadrants (d) II, IV quadrants

Ans: (d)



9) Amount required for buying 50 shares, Rs 75 quoted at Rs 71.50.

- (a) 3750/- (b) 3575/- (c) 3475/- (d) 5363/-

Ans: (b)

10) The conversion of (4, -1, -8) in cylindrical coordinates represented by:

- (a) $(\sqrt{17}, 3.3866, 8)$ (b) $(\sqrt{19}, 4.876, 8)$ (c) $(\sqrt{17}, 8, 3.3866)$ (d) $(\sqrt{17}, -1, 8)$

Ans: (a)

11) The a relation between x and y if the point (x , y) is equidistant from the points (7, 1) and (3, 5).

- (a) $x-y=5$ (b) $x-y=2$ (c) $x+y=2$ (d) $x+y=5$

12) General notation for cartesian coordinates system is:

- (a) (x,y,z) (b) (r, θ, ϕ) (c) (r, θ, z) (d) None of these

13) $9\sec^2 A - 9 \tan^2 A$ is

- a) 1 b) 9 c) 8 d) 0

14) A flooring tile has the shape of a parallelogram whose base is 24 cm and the corresponding height is 10 cm. How many such tiles are required to cover a floor of area 1080 m²?

- a) 15000 b) 30000 c) 45000 d) 12000

15) The lateral surface area of sphere is

- a) $4\pi r^2$ b) $4\pi r$ c) $2\pi r^2$ d) πr^2

16) The property of material by virtue of which it can resist the abrasion and scratches

- a) Ductility b) Hardness c) Malleability d) Stiffness

17) The oak wood has a mass of 134 kg and a volume of 194 dm³ What is the density?

- (a) 1.44 kg/dm³ (b) 0.69 kg/dm³ (c) 0.89 kg/dm³ (d) 1.34 kg/dm³

18) cosec(90-A) is

- (a) sin A b) tan A c) sec A d) None

19) $\frac{\tan 26^\circ}{\cot 64^\circ} =$

- (a) 2 b) 1 c) 0 d) None

20) The area of a rhombus is 240 cm² and one of the diagonals is 16 cm. The length of another diagonal is

- a) 15 cm b) 30 cm c) 32 cm d) 12 cm



(Attempt any 06 questions out of 08 questions)

21) Write short notes on: a) Dry and wet bulb temperature b) tensile and compressive strength.

Solution:

a) Dry bulb temperature It is the temperature of air recorded by a thermometer, when it is not affected by the moisture present in the air. The dry bulb temperature (briefly written as DBT) is generally denoted by t_d or t_{db} . Wet bulb temperature It is the temperature of air recorded by a thermometer, when its bulb is surrounded by a wet cloth exposed to the air. Such a thermometer is called *wet bulb thermometer. The wet bulb temperature (briefly written as WBT) is generally denoted by t_w or t_{wb} . At 100% relative humidity, the wet-bulb temperature is equal to the air temperature (dry-bulb temperature) and is lower at lower humidity.

b) Tensile strength :The tensile strength of wood parallel to the grain depends upon the strength of the fibers and is affected not only by the nature and dimensions of the wood elements but also by their arrangement. Compressive or crushing strength :Is very closely related to hardness and transverse shear. There are two ways in which wood is subjected to stress of this kind, namely, (1) with the load acting over the entire area of the specimen, and (2) with a load concentrated over a portion of the area.

22) Mukul invests Rs 9000 in a company paying a dividend of 6% per annum when a share of NV Rs 100 stands at Rs 150. What is his annual income? If he sells 50% of his shares when the price rises to Rs 200, what is his gain in this transaction?

Solution:

No. of shares bought by Mukul $((Investment)/MV)=9000/150=60$

His annual income on 1 share=6% of NV=6% of Rs 100= Rs 6

His total annual income= $(60 \times Rs 6) = Rs 360$

Since, 50% of shares= 50% of 60 =30

Money received on selling these shares = $(30 \times Rs 200)=Rs 6000$

Also, cost of these shares= $(30 \times Rs 150)=Rs 4500$

Therefore, Mukul's gain = Rs (6000-4500) = Rs 1500

23) Show that the points (1, 7), (4, 2), (-1, -1) and (-4, 4) are the vertices of a square.

Solution:

Let A(1, 7), B(4, 2), C(-1, -1) and D(-4, 4) be the given points. One way of showing that ABCD is a square is to use the property that all its sides should be equal and both its diagonals should also be equal. Now,

$$AB = \sqrt{(1-4)^2 + (7-2)^2} = \sqrt{9+25} = \sqrt{34}$$

$$BC = \sqrt{(4+1)^2 + (2+1)^2} = \sqrt{25+9} = \sqrt{34}$$

$$CD = \sqrt{(-1+4)^2 + (-1-4)^2} = \sqrt{9+25} = \sqrt{34}$$

$$DA = \sqrt{(1+4)^2 + (7-4)^2} = \sqrt{25+9} = \sqrt{34}$$

$$AC = \sqrt{(1+1)^2 + (7+1)^2} = \sqrt{4+64} = \sqrt{68}$$

$$BD = \sqrt{(4+4)^2 + (2-4)^2} = \sqrt{64+4} = \sqrt{68}$$

Since, $AB = BC = CD = DA$ and $AC = BD$, all the four sides of the quadrilateral ABCD are equal and its diagonals AC and BD are also equal. **Therefore, ABCD is a square.**

24) Prove that $\left(\frac{\sin\theta - 2\sin^3\theta}{2\cos^3\theta - \cos\theta}\right) = \tan\theta$

Solution:

$$\text{L.H.S} = \frac{\sin\theta - 2\sin^3\theta}{2\cos^3\theta - \cos\theta}$$

Taking Sin θ and Cos θ common in both numerator and denominator respectively.

$$= \frac{\sin\theta(1 - 2\sin^2\theta)}{\cos\theta(2\cos^2\theta - 1)}$$

By Identity $\sin^2A + \cos^2A = 1$ hence, $\cos^2A = 1 - \sin^2A$ and substituting this in the above equation,

$$= \frac{\sin\theta(1 - 2\sin^2\theta)}{\cos\theta\{2(1 - \sin^2\theta) - 1\}}$$

$$= \frac{\sin\theta(1 - 2\sin^2\theta)}{\cos\theta(1 - 2\sin^2\theta)}$$

$$= \frac{\sin\theta}{\cos\theta} = \tan\theta$$

25) Find a relation between x and y such that the point (x, y) is equidistant from the points (7, 1) and (3, 5).

Solution: Let P(x, y) be equidistant from the points A(7, 1) and B(3, 5).

We are given that $AP = BP$. So, $AP^2 = BP^2$

$$\text{i.e., } (x-7)^2 + (y-1)^2 = (x-3)^2 + (y-5)^2$$

$$\text{i.e., } x^2 - 14x + 49 + y^2 - 2y + 1 = x^2 - 6x + 9 + y^2 - 10y + 25$$

$$\text{i.e., } x - y = 2$$



26) Do the points (3, 2), (-2, -3) and (2, 3) form a triangle? If so, name the type of triangle formed.

Solution: Let us apply the distance formula to find the distances PQ, QR and PR, where P(3, 2), Q(-2, -3) and R(2, 3) are the given points. We have

$$PQ = \sqrt{(3+2)^2 + (2+3)^2} = \sqrt{5^2 + 5^2} = \sqrt{50} = 7.07 \text{ (approx.)}$$

$$QR = \sqrt{(-2-2)^2 + (-3-3)^2} = \sqrt{(-4)^2 + (-6)^2} = \sqrt{52} = 7.21 \text{ (approx.)}$$

$$PR = \sqrt{(3-2)^2 + (2-3)^2} = \sqrt{1^2 + (-1)^2} = \sqrt{2} = 1.41 \text{ (approx.)}$$

Since the sum of any two of these distances is greater than the third distance, therefore, the points P, Q and R form a triangle.

27) if $3 \cot A = 4$, check whether $\frac{1-\tan^2 A}{1+\tan^2 A} = \cos^2 A - \sin^2 A$ or not.

Given,
Let $\triangle ABC$ be a right angled triangle.

$$\bullet \quad 3 \cot A = 4$$

$$\text{Hence, } \cot A = \frac{4}{3}$$

We know that,

$$\cot A = \frac{\text{Side adjacent to } \angle A}{\text{Side opposite to } \angle A} = \frac{AB}{BC} = \frac{4}{3}$$

Hence, $AB = 4$ and $BC = 3$. $AC = ?$

By applying the Pythagoras Theorem in $\triangle ABC$,

$$\begin{aligned} (AC)^2 &= (AB)^2 + (BC)^2 \\ &= 4^2 + 3^2 \\ &= 16 + 9 \\ &= 25 \end{aligned}$$

$$AC = 5$$

$$\cos A = \frac{\text{Side adjacent to } \angle A}{\text{Hypotenuse}} = \frac{AB}{AC} = \frac{4}{5}$$

$$\sin A = \frac{\text{Side opposite to } \angle A}{\text{Hypotenuse}} = \frac{BC}{AC} = \frac{3}{5}$$

$$\tan A = \frac{\text{Side opposite to } \angle A}{\text{Side adjacent to } \angle A} = \frac{BC}{AB} = \frac{3}{4}$$

By substituting the above values of trigonometric functions in the LHS of the Equation,

$$\frac{1-\tan^2 A}{1+\tan^2 A} = \frac{1-\left(\frac{3}{4}\right)^2}{1+\left(\frac{3}{4}\right)^2} = \frac{1-\frac{9}{16}}{1+\frac{9}{16}}$$

$$= \frac{\frac{16}{16}-\frac{9}{16}}{\frac{16}{16}+\frac{9}{16}} = \frac{7}{25}$$

By substituting the above values of trigonometric functions in the RHS of the Equation

$$\cos^2 A - \sin^2 A = \left(\frac{4}{5}\right)^2 - \left(\frac{3}{5}\right)^2$$

$$= \frac{16}{25} - \frac{9}{25} = \frac{7}{25}$$

$$\therefore \frac{1-\tan^2 A}{1+\tan^2 A} = \cos^2 A - \sin^2 A$$

Hence it is proved.

28) Convert the following equation written in Cartesian coordinates into an equation in Cylindrical coordinates.

$$x^3 + 2x^2 - 6z = 4 - 2y^2$$

Solution:

$$x = r \cos \theta, \quad y = r \sin \theta \quad r^2 = x^2 + y^2$$



BHARTIYA SKILL DEVELOPMENT UNIVERSITY

Using these values of x, y, and r

$$x^3 + 2x^2 + 2y^2 - 6z = 4 \quad \rightarrow \quad x^3 + 2(x^2 + y^2) - 6z = 4$$

Ans: $r^3 \cos^3 \theta + 2r^2 - 6z = 4$

Section – C

05X10 = 50 Marks

05 essay type questions, each question carries 10 marks.

29) Write short notes on: a) Dry and wet bulb temperature b) tensile and compressive strength.

Solution:

a) Dry bulb temperature It is the temperature of air recorded by a thermometer, when it is not affected by the moisture present in the air. The dry bulb temperature (briefly written as DBT) is generally denoted by t_d or t_{db} . Wet bulb temperature It is the temperature of air recorded by a thermometer, when its bulb is surrounded by a wet cloth exposed to the air. Such a thermometer is called *wet bulb thermometer. The wet bulb temperature (briefly written as WBT) is generally denoted by t_w or t_{wb} . At 100% relative humidity, the wet-bulb temperature is equal to the air temperature (dry-bulb temperature) and is lower at lower humidity.

b) Tensile strength :The tensile strength of wood parallel to the grain depends upon the strength of the fibers and is affected not only by the nature and dimensions of the wood elements but also by their arrangement. Compressive or crushing strength :Is very closely related to hardness and transverse shear. There are two ways in which wood is subjected to stress of this kind, namely, (1) with the load acting over the entire area of the specimen, and (2) with a load concentrated over a portion of the area.

30) Explain the influence of moisture on mechanical properties of wood-based products.

Solution:

Wood is a material that continually absorbs or releases moisture until it reaches a balance with its surroundings. In normal use the moisture content of wood varies between 8% and 25% by weight, depending on the relative humidity of the air. On the other hand, an excess of moisture in wood can cause other problems, including, but not limited to: Preventing adhesives from making a secure bond (Less strength) and Shrinkage as the excess moisture leaves the wood:

Shrinkage occurs as moisture content decreases, while swelling takes place when it increases. Volume change is not equal in all directions. The greatest dimensional change occurs in a direction tangential to the growth rings. Shrinkage from the pith outwards, or radially, is usually considerably less than tangential shrinkage, while longitudinal (along the grain)



BHARTIYA SKILL DEVELOPMENT UNIVERSITY

shrinkage is so slight as to be usually neglected. The longitudinal shrinkage is 0.1% to 0.3%, in contrast to transverse shrinkages, which is 2% to 10%. Tangential shrinkage is often about twice as great as in the radial direction, although in

some species it is as much as five times as great. The shrinkage is about 5% to 10% in the tangential direction and about 2% to 6% in the radial direction.

31) Robert bought shares of 6% \$ 100 shares at \$ 120. Adrian bought shares of 8% \$ 20 shares at \$ 30. Whose investment was better?

Solution:

6% \$ 100 shares at \$ 120

i.e., the annual income from 1 share of nominal value \$ 100 is \$ 6, investment for 1 share being \$ 120.

Therefore, profit percentage = $\frac{6}{120} \times 100\% = 5\%$

Therefore, Robert's shares give him a profit of 5%

8% \$ 20 shares at \$ 30

i.e., the annual income from 1 share of nominal value \$ 20 is \$ $\frac{8 \times 20}{100} = \$ \frac{8}{5}$, investment for 1 share being \$ 30.

$$\begin{aligned} \text{Profit percentage} &= \frac{\$ \frac{8}{5}}{\$ 30} \times 100\% \\ &= \frac{16}{3}\% \\ &= 5\frac{1}{3}\% \end{aligned}$$

Therefore, Adrian's shares give him a profit of $5\frac{1}{3}\%$

Therefore, Adrian's investment was better.

32) Prove that $\left(\frac{1+\tan^2 A}{1+\cot^2 A}\right) = \left(\frac{1-\tan A}{1-\cot A}\right)^2 = \tan^2 A$

Solution:

$$\begin{aligned} \text{LHS} &= \frac{1+\tan^2 A}{1+\cot^2 A} = \frac{\sec^2 A}{\operatorname{cosec}^2 A} = \frac{1}{\frac{1}{\sin^2 A}} \\ &= \frac{\sin^2 A}{\cos^2 A} = \tan^2 A. \end{aligned}$$

$$\begin{aligned} \text{RHS} &= \left(\frac{1-\tan A}{1-\cot A}\right)^2 = \left(\frac{1-\frac{\sin A}{\cos A}}{1-\frac{\cos A}{\sin A}}\right)^2 \\ &= \left(\frac{\frac{\cos A - \sin A}{\cos A}}{\frac{\sin A - \cos A}{\sin A}}\right)^2 \end{aligned}$$

$$\begin{aligned} &= \frac{(\cos A - \sin A)^2 \times \sin^2 A}{(\sin A - \cos A)^2 \times \cos^2 A} \\ &= \frac{(\sin A - \cos A)^2 \times \sin^2 A}{(\sin A - \cos A)^2 \times \cos^2 A} \\ &= \frac{\sin^2 A}{\cos^2 A} = \tan^2 A. \end{aligned}$$

\therefore LHS = RHS Hence, **proved.**



BHARTIYA SKILL DEVELOPMENT UNIVERSITY

33) In a building there are 24 cylindrical pillars. The radius of each pillar is 28 cm and height is 4 m. Find the total cost of painting the curved surface area of all pillars at the rate of INR 8 per m^2 .

Solution:

Radius of cylindrical pillar, $r = 28 \text{ cm} = 0.28 \text{ m}$

height, $h = 4 \text{ m}$

curved surface area of a cylinder = $2\pi rh$

curved surface area of a pillar = $2 \times \frac{22}{7} \times 0.28 \times 4 = 7.04 \text{ m}^2$

curved surface area of 24 such pillar = $7.04 \times 24 = 168.96 \text{ m}^2$

cost of painting an area of $1 \text{ m}^2 = ₹ 8$

Therefore, cost of painting $1689.6 \text{ m}^2 = 168.96 \times 8 = ₹ 1351.68$

School of Woodworking Skills
Session: 2020-21 (Summer Semester)
B. Voc. Program, 3rd Semester,
End-Sem. Examination

With Answer Key

Course Code: SCS1305

Time: 3 Hours

Course Name: Wood Working CNC Machines

Max. Marks: 100

Instruction:

- Answer all questions from section A, each question carries one mark.
- Answer any 6 question in section B, each question carries five marks.
- Answer all question from section C, each question carries ten marks.

Section – A

20X01 = 20 Marks

Q.1.Which type of the Path mode given in fig.?

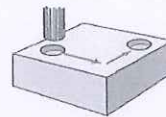

(A)

(A) Point control

(B) 2D path control

(C) 3D path control

(D) None of these

Q.2.Series hole is the example of _____control mode?

(B)

(A) Point control

(B) 2D path control

(C) 3D path control

(D) None of these

Q.3.Wooden figures is the example of _____control mode?

(C)

(A) Point control

(B) 2D path control

(C) 3D path control

(D) None of these

Q.4.Which one of the following is the required compressed air for connections in CNC Router?

(C)

(A) 9-10 bar

(B) 2-7 bar

(C) 6-7 bar

(D)10-11 bar

Q.5. Which type of CNC machine is installed in our workshop?

(A)

(A) Boom type

(B) Moving Gentry

(C) Both (A) & (B)

(D) None of these

Q.6.What is name of System accessory given in figure?

(B)



(A) Hydro Feed

(B) Collect chuck

(C) Heat-Shrink fit chucks

(D) Cross Stop

Q.7.All the programs cab be started from_____?

(A)

(A) CNC Board

(B) Techno Manager

(C) Program Editor

(D) Tool Arch

Q.8.The working order of the individual programs cab be defined in list form from_____?(A)

- (A) CNC Board (B) Techno Manager
(C) Program Editor (D) Tool Arch

Q.9.When tooling has been sharped the data must be updated in_____? (B)

- (A) CNC Board (B) Techno Manager
(C) Program Editor (D) Tool Arch

Q.10.Which one of the following axis is known as 4th axis? (D)

- (A) X axis (B) Y axis
(C) Z axis (D) C axis

Q.11.Which type of the Path mode given in fig.? (B)

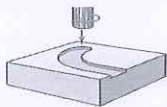

- (A) Point control (B) 2D path control
(C) 3D path control (D) None of these

Q.12.Laser Cutting is the example of _____control mode? (B)

- (A) Point control (B) 2D path control
(C) 3D path control (D) None of these

Q.13.Wooden figures is the example of _____control mode? (C)

- (A) Point control (B) 2D path control
(C) 3D path control (D) None of these

Q.14.Which one of the following is the required Suction Power for connections in CNC Router? (A)

- (A) 4000 to 5000 m/h (B) 3000 to 4000 m/h
(C) 2000 to 3000 m/h (D) 5000 to 6000 m/h

Q.15.32 mm drill system is the example of_____control mode? (A)

- (A) Point control (B) 2D path control
(C) 3D path control (D) None of these

Q.16.What is name of System accessory given in figure?



- (B) Hydro Feed (B) Collect chuck (A)
(C) Heat-Shrink fit chucks (D) Cross Stop

Q.17.Display of CNC Working fields, consoles and vacuum pods are shown in_____?A)

- (A) CNC Board (B) Techno Manager
(C) Program Editor (D) Tool Arch

Q.18.The working order of the individual programs cab be defined in list form from_____?

(A)

- (A) CNC Board
- (C) Program Editor

- (B) Techno Manager
- (D) Tool Arch

- Q.19. All the tooling data has been found in _____? (B)
- (A) CNC Board
 - (B) Techno Manager
 - (C) Program Editor
 - (D) Tool Arch
- Q.20. Which one of the following is the face where machining is not possible? (B)
- (A) Face 1
 - (B) Face 2
 - (C) Face 3
 - (D) Face 4

Section – B



06X05 = 30 Marks

Q.21. Why it is necessary to warm up the CNC Router?

Ans. It needs a little bit of a warm up before working at full speed. This distributes lubrication oil evenly, which reduces wear on your CNC machine and increases its life. As you know, heat can also cause your machine and its tools to expand, even if ever-so-slightly. But, you don't even want a little expansion because that affects the precision of your cutting. Warming your machine up keeps it operating at a stable temperature so you don't have to worry about that.

Q.22. What is control mode in CNC? Explain the types of control modes.

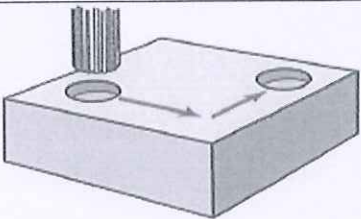
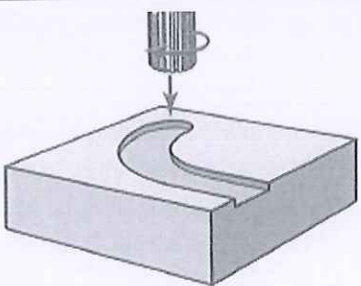
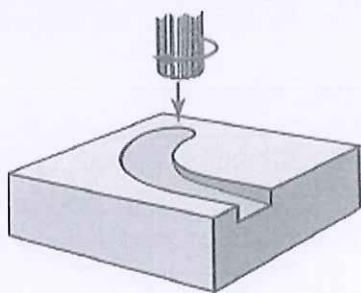
Ans. The type of control describes the way how the axes of a CNC Machine is controlled and moved and how the tool Material processed.

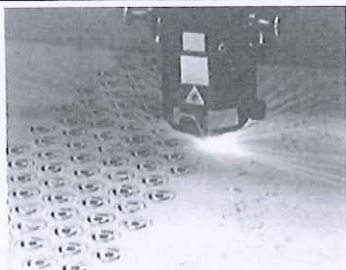
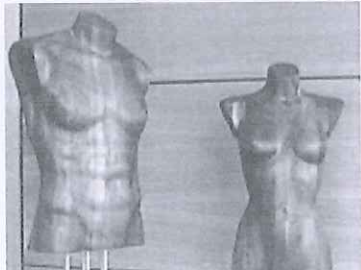
point control	2D path control	3D path control
		
		
Series hole	laser cutting	Wooden figures

Tool edited only after the Positioning in one Direction	Two axes will be simultaneously synchronous controlled	Three or more axes be at the Processing in time synchronous controlled
---	--	--

Q.23.What are the requirements for connections and buildings of CNC Router?

Ans. Requirements for connections and buildings:

1. Electrical connection value, 20 to 30 kW
2. Compressed air, 7bar
3. Suction power, 4000 to 5000 m / h
4. Floor load, 2000 kg / m²
5. Sufficient floor space

Q.24.What are the types of CNC Machine? Explain it.

Ans. **Boom type:**

The cantilever type requires comparatively little space, is one light and rather inexpensive CNC machine. Likewise, she can be fed without restriction from the front. This CNC machine is mostly used for plane-shaped parts.

Moving Gentry Design:

The term << gantry >> is a subspecies of Portal design, where the Sub frame built over the machine table and thus on both sides is guided and held. Compared to the classic portal design does not move the table, but the portal. This design is low-vibration and to accommodate heavy auxiliary equipment suitable.

Q.25.What are the major axes in CNC Router? Explain it.

Ans. Main axes X, Y, Z

With the three main axes of movement, every point in the room can be approached. However, the tool is always perpendicular to an axis. Thus, for example, no oblique holes or saw cuts in any angle possible.

Rotary axes a, b, c

In order to programmatically perform inclined drilling and bevel cuts with saw blade, further controlled axes are used with corresponding angle gears. Widely used is the so-called C-axis, which, for example, can turn a saw blade around the Z-axis so that angle cuts are possible.

Q.26.Define the term CNC and WOP.

Ans. **CNC (Computerized Numerical Control):** - CNC machines are machine tools that, thanks to the use of Computer-controlled measuring and coordinate systems, are able to automatically produce work pieces with high precision, even for complex shapes. They outperform mechanically controlled machines in terms of precision and speed.

WOP (Workshop-oriented programming): - Most machine suppliers sell their machines with a WOP. These CAD-like programs simplify programming for the operator and represent the work piece with the machining graphically.

Q.27. What are the functions of Suction Cup?

Ans. Tables with brackets, on which vacuum cups are placed arbitrarily, are used to clamp work pieces. Due to the adjustability of the brackets in the X-axis and the adjustability of the suction cups in the Y-axis different sized work pieces can be tensioned. Falling chips fall between the consoles and so hinder the operation a little. There are also plain tables with the corresponding vacuum blocks, grid tables and clamping templates.

Q.28. Briefly describe the faces of work piece used for a program in CNC Router with the help of a diagram.

Ans.

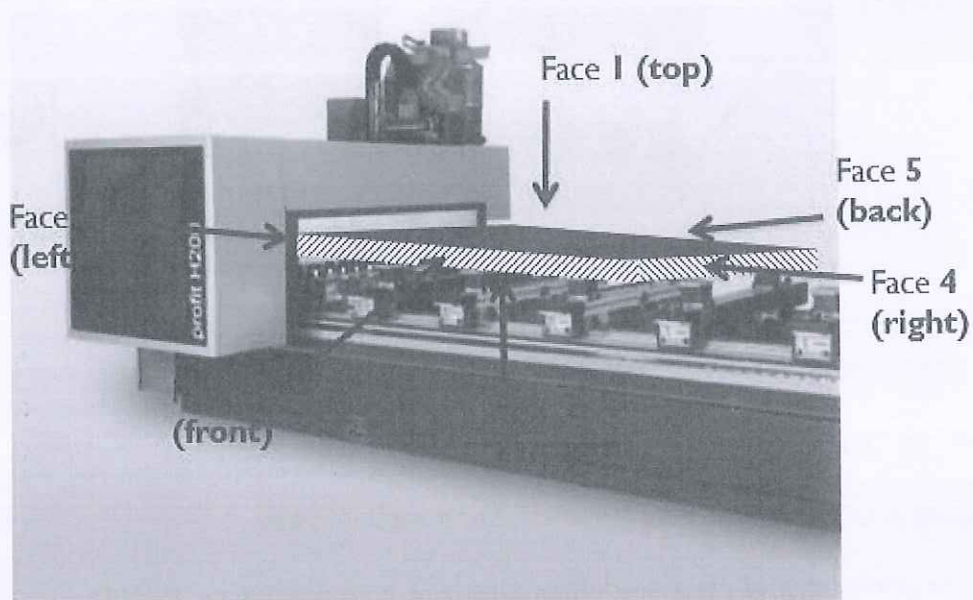

Section – C

05X10 = 50 Marks

Q.29. Explain the program overview of CNC Router with the help of block diagram.

Ans.

The program is divided into different categories, machine operation, work piece programming and simulation.

Program	Categories	Under Program	Symbol
---------	------------	---------------	--------

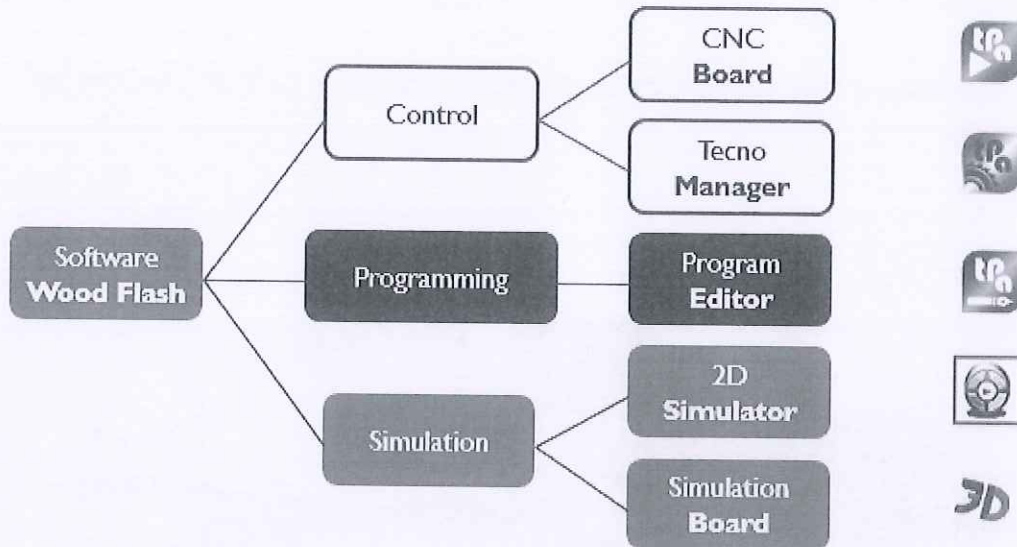

Q.30. What are the functions of CNC board and Techno Manager?

Ans. CNC Board:-

- > Main menu, all the programs can be started from here
- > Display of CNC working fields, consoles and vacuum pods
- > The working order of the individual programs is here defined in list form

Techno Manager: -

- > The machine will be loaded with the tooling that where entered into the Tool

Parameters program

- > Each tool is placed in one of the free tool loading positions on the machine

Q.31. Briefly describe the Absolute dimension and Relative dimensioning.

Ans. Absolute dimension

The absolute dimension refers to a zero point and is therefore also called reference.

Absolute dimensioning is the basis for the CNC program creation particularly suitable. It is easy to interpret and can be easily converted into a program. Similarly, edits can easily be compared and controlled with the plan.

Relative dimensioning:

The measures always refer to the previously measured point. If you change the dimensions of the previous point, all other points will be moved automatically. This can lead to errors, but is also very handy for edits that need to be moved together. For example, in a series hole drilling, if the first hole is moved, all the other holes should also be moved. The relative dimensioning is also known as chain or incremental.

Q.32. What are the functions of 2D Simulator and 3D Simulator?

Ans. The working time can be simulated here.

- > Adjustable speed from 1/256- to 256-times the real speed.
 - > The working order of a program can be checked and changed
- The working time can be simulated here.

- > Adjustable speed from 1/256- to 256-times the real speed.
- > The working order of a program can be checked and changed

Q.33. Explain the vacuum clamping in CNC Router?

Ans. Tables with brackets, on which vacuum cups are placed arbitrarily, are used to clamp work pieces. Due to the adjustability of the brackets in the X-axis and the adjustability of the suction cups in the Y-axis different sized work pieces can be tensioned. Falling chips fall between the consoles and so hinder the operation a little. There are also plain tables with the corresponding vacuum blocks, grid tables and clamping templates.

School of Woodworking Skills

Session: 2020-21 (Summer / Winter Semester)

B. Voc. 3rd Semester

End-Sem. Examination (Make-up)

Course Code: SC1307

Time: 3 Hours

Course Name: Advance Carpenter Materials

Max. Marks: 100

Instruction: (if any)

Section – A

20X01 = 20 Marks

Q 1). Which part of the trunk is known as growth tissue (forms new cells through cell division)?

- (a) Core (b) Sapwood
(c) Cambium (d) Bast

Q 2). Where is Sapwood located in the structure of softwood stem?

- (a) Between cambium and core (b) Between bast and bark
(c) Between pith and core (d) Between cambium and bast

Q 4). Adhesive that sets through evaporation of water

- (a) Dispersion adhesive (b) Hot melt adhesive
(c) Reaction adhesive (d) Contact adhesive

Q 5). Which process is not used for changing the wood colour?

- (a) Bleaching (b) Pickling
(c) Patinate (d) Equilize

Q 6). Glass becomes hard on heating.

- (a) True (b) False

Q 7). In HGP laminate, P stands for

- (a) Pressurized (b) Post formed
(c) Preprocessed (d) Penetrated

Q 8). Which process is not used for changing the wood colour?

- (a) Bleaching (b) Pickling
(c) Patinate (d) Equilize

Q 9). Tensile strength is

- (a) Strength of fiber (b) total deformation
(c) Hardness of wood (d) None

Q 10). The property of material that resist the loads applied to it without failure

- a) Strength b) Hardness
c) Resilience d) None

- Q 11). Veneers that are visible on the finished work-piece are known as
(a) Blind veneer (b) Covering veneer
(c) Deck veneer (d) Barrier veneer
- Q 12). The property of material that absorb the energy by shocks is
a) Strength b) Hardness c) Resilience d) None
- Q 13). Which of the following is not used as a coating material in woodworking?
(a) Varnish (b) Glaze
(c) Oil (d) Water
- Q 14). Thermal insulation glass is a kind of
(a) Safety Glass (b) Functional Glass
(c) Ornamental Glass (d) Decorative Glass
- Q 15). In HGF laminate, F stands for
(a) Pressurized b) Post formed
(c) Preprocessed (d) Fire retardant
- Q 16). European or commonly used grade for laminate is
(a) EN 532 (b) EN 338
(c) EN 438 (d) None
- Q 17) The Aluminum Oxide used for wood working as
(a) adhesive (b) cleaning agent
(c) abrasive (d) None
- Q 18) The property of wood that resists abrasion and scratches
a) Strength b) Hardness c) Resilience d) None
- Q 19). The colour of cellulose fibers is?
(a) White (b) Black
(c) Gray (d) Brown
- Q 20). The speed at which the tool cutting edge moves
(a) Feed rate (b) Cutting speed
(c) Impregnation (d) None of these

Section – B

06X05 = 30 Marks

(Attempt any 06 questions out of 08 questions)

- Q 21). Write in detail about the hot melt adhesives, their types and working instructions.
- Q 22). Write in detail about the decorative glasses.
- Q 23). What are the advantages of Linoleum?
- Q 24). Write short note on bonded and coated abrasive.

Q 25). Write briefly on the following veneer defects.

- (a) Furrier (b) Glue penetration

Q 26). Write the advantages of using glasses in woodworking.

Q27). Explain the following:

- (a) Compact panels (b) Edge materials

Q 28) Define following:

- a) Plastic films b) Bonded abrasive

Section – C

05X10 = 50 Marks

Q. 29) Explain the storage of Water content in the wood with diagram.

Q 30). Explain the bleaching and pickling processes used for changing the wood colour.

Q 31). Write the instructions for veneer storage in detail.

Q 32). Explain the processing of HP laminate.

Q 33) Explain major characteristics of Laminate.

School of Woodworking Skills
Session: 2020-21 (Summer / Winter Semester)
B. Voc. 3rd Semester,
End-Sem. Examination (Make-up)

Course Code: SC1307

Time: 3 Hours

Course Name: Advance Carpenter Materials

Max. Marks: 100

Instruction: (if any)

Section – A

20X01 = 20 Marks

Q1. Which part of the trunk is known as growth tissue (forms new cells through cell division)?

- (a) Core (b) Sapwood
(c) Cambium (d) Bast (c)

Q2. Where is Sapwood located in the structure of softwood stem?

- (a) Between cambium and core (b) Between bast and bark
(c) Between pith and core (d) Between cambium and bast (a)

Q4. Adhesive that sets through evaporation of water

- (a) Dispersion adhesive (b) Hot melt adhesive
(c) Reaction adhesive (d) Contact adhesive

Q5. Which process is not used for changing the wood colour?

- (a) Bleaching (b) Pickling
(c) Patinate (d) Equilize

Q6. Glass becomes hard on heating.

- (a) True (b) False

Q7. In HGP laminate, P stands for

- (a) Pressurized (b) Post formed
(c) Preprocessed (d) Penetrated

Q8. Which process is not used for changing the wood colour?

- (a) Bleaching (b) Pickling
(c) Patinate (d) Equilize

Q9. Tensile strength is

- (a) Strength of fiber (b) total deformation
(c) Hardness of wood (d) None

Q10. The property of material that resist the loads applied to it without failure

- a) Strength b) Hardness
c) Resilience d) None

Q11. Veneers that are visible on the finished work-piece are known as



- (a) Blind veneer (b) Covering veneer
- (c) Deck veneer (d) Barrier veneer (b)
- Q12. The property of material that absorb the energy by shocks is
a) Strength b) Hardness c) Resilience d) None (c)
- Q13. Which of the following is not used as a coating material in woodworking?
(a) Varnish (b) Glaze
(c) Oil (d) Water (d)
- Q 14. Thermal insulation glass is a kind of
(a) Safety Glass (b) Functional Glass
(c) Ornamental Glass (d) Decorative Glass (b)
- Q15. In HGF laminate, F stands for
(a) Pressurized b) Post formed
(c) Preprocessed (d) Fire retardent (b)
- Q16. European or commonly used grade for laminate is
(a) EN 532 (b) EN 338
(c) EN 438 (d) None (c)
- Q17. The Aluminum Oxide used for wood working as
(a) adhesive (b) cleaning agent
(c) abrasive (d) None (c)
- Q 18 The property of wood that resists abrasion and scratches
a) Strength b) Hardness c) Resilience d) None
(b)
- Q19. The colour of cellulose fibres is?
(a) White (b) Black
(c) Gray (d) Brown
- Q20. The speed at which the tool cutting edge moves
(a) Feed rate (b) Cutting speed
(c) Impregnation (d) None of these

Section – B

06X05 = 30 Marks

(Attempt any 06 questions out of 08 questions)

Q21. Write in detail about the hot melt adhesives, their types and working instructions.

Ans.

Hot melt adhesives

The edge gluing machine and the hot melt glue gun work with hot melt adhesives, which cause the workpieces to glue by solidifying the adhesive. For this purpose, the adhesives

are melted at over 100 ° C, applied to the workpieces and cooled by the ambient temperature. Two common hot melt adhesive groups are available on the market.

EVA hot melt adhesive made of plastomeric plastics for the univer use that become soft again when exposed to heat.

Reactive PUR hotmelt adhesives which have an initial strength after the adhesive mass has solidified. In addition, the macromolecules cross-link over time, forming elastomeric plastic layers. These cannot be melted again.

EVA hot melt adhesives

EVA hot melt adhesives were manufactured for their universal use in edge glue machines. The most important properties are the low viscosity and the good wetting of the edge materials. A tight adhesive joint with a high final strength is created, which can be veneered. The disadvantages of EVA edge joints are visibility on the surface and releasability when exposed to heat, such as in the vicinity of ovens or the like.

PUR hot melt adhesives

These adhesives were developed for high resistance to solvents, water, steam, heat and cold. Polyurethane hot melt adhesive is a reactive adhesive that, in addition to the physical setting, i.e. H. by cooling, additionally sets chemically. The necessary initial strength when leaving the machine is achieved through the normal physical setting process. Thereupon a chemical cross-linking of the molecules starts in the following days due to moisture.

Work instructions

Checking the correct temperature at the time of applying is very important. This must remain constant during the gluing process until the parts are pressed together. Drafts can lead to incorrect bonding because the temperature drops sharply. The perfect fit of the joint is essential for a perfect joint pattern. Panel material cut at right angles is absolutely necessary for a flawless production process.

Q22. Write in detail about the decorative glasses.

Ans.

Decorative glasses

Decorative glasses enable attractive designs in the kitchen, living room and office space with great individuality and a long service life. Decorative glasses combined with light also achieve a unique material effect. They can be offered mirrored by means of enamelling in a wide range of colors or customized with high-quality screen printing.

Colored glasses (enamelled glass)

Glass cladding made of colored glass allows for attractive design options in the interior. Seamless wall coverings are practical, hygienic and easy to maintain. There is a large color collection to choose from. The glass plates are enamelled on the underside with colors. During the tempering process, the ceramic colors permanently fuse with the glass, thereby gaining strength and intensity.

A thickness of 12mm is normally preferred for the realization of the worktops. A glass thickness of 6mm is sufficient for rear walls and cladding.

Screen printed glasses

Using screen printing technology, any motifs such as photos or graphics can be printed directly on the glass and permanently melted as enamelled glass. The motifs can subsequently be brought to bear using various methods.

Silver plating - With the two versions "silvering" and "partial silvering", the glass can be processed with unique specular reflections to create glamorous unique glass pieces.

Translucent - In this version, too, the colored motif is first coated transparently on the back of the glass and then backed with an additional white coating. The light scattering is thus diffuse and is partially or fully permeable. The parts of the picture that shine through are specially staged. Optimal light sources are LED panels or fluorescent tubes. The translucent version is particularly recommended for wall cladding, counters, advertising spaces and decorative elements.

Covering - The back glass side is coated with a motif absolutely opaque. This solution is mostly used for kitchen rear walls, wall cladding, furniture fronts and murals.

Backlit glasses - With backlit glass, an absolutely evenly illuminated surface is expected. The translucent colored or white coating on the back and the velvety glass surface make this claim a reality. This technology is ideal for wall cladding in interior design, kitchen construction, furniture construction, in shop and trade fair construction as well as for illuminated and advertising boards.

Q23. What are the advantages of Linoleum?

Ans:

- Environmentally, linoleum has a great deal going for it. The product is made primarily from minimally processed natural ingredients.
- It contains almost no petroleum-based chemicals and no chlorinated chemicals. The resources used are renewable or plentiful. It is fully biodegradable.



From a life-cycle cost standpoint, the lower maintenance requirements will result in significant savings over time.

- Linoleum is a warm material
- Linoleum is a natural material
- There is no electrostatic charge on linoleum
- Linoleum is resistant to a wide range of chemicals
- Linoleum inhibits bacterial growth, which is why it is used in buildings used as a floor covering with increased hygiene requirements becomes.

Q24. Write short note on bonded and coated abrasive.

Ans:

A bonded abrasive is composed of an abrasive material contained within a matrix, although very fine aluminium oxide abrasive may comprise sintered material. This matrix is called a

binder and is often a clay, a resin, a glass or a rubber. This mixture of binder and abrasive is typically shaped into blocks, sticks, or wheels. The most common abrasive used is aluminium oxide. Also common are silicon carbide, tungsten carbide and garnet. Another examples of bonded abrasive is grinding wheel.

A coated abrasive is an abrasive grain bonded to a flexible base like paper, cloth, vulcanised fibre or plastic film. Sand paper is an excellent example. Such abrasives come in various grit sizes, ranging from a very coarse 2mm grain to ultra fine grains of less than a millimetre in

diameter. As you can imagine some abrasives are better for certain jobs than others, some are designed for working by hand and others specifically for use with machines like an orbital sander, belt sander or drum sander.

25) Write briefly on the following veneer defects.

(a) Furrier

(b) Glue penetration

Ans.

Types of errors	Possible Cause	Eliminate errors	Avoidance in the future
Furrier	Dirt or grease	- Cut out the missing part, insert the adhesive and press again	- Check, grind and clean the carrier plate
	Too little glue		- Even adhesive application
	Defects in the veneer		- Check the veneer, especially the
	Uneven veneer thicknesses		
	Uneven support plate		

			thickness
Glue penetration	- Adhesive too thin	- For dispersion glue (white glue without hardener), brush with warm water and a root or brass brush immediately after removal from the press	- Add filler and extender to the 1 adhesive
	- Too much glue applied	- other types of adhesive can no longer be removed	- Adjust the adhesive more viscous
	- Coarse pore veneer		- Color the adhesive
	- Forget about fillers and extenders		

Q26. Write the advantages of using glasses in woodworking.

Ans.

Group 3: Hot melt adhesives

Hot melt adhesives are used in edge banding machines and hot melt glue guns in granulate or cartridge form. Hot melt adhesives are heated and applied in a molten state. They harden by cooling from the hot liquid to the cool, hard state.

Properties of hot melt adhesives

- Hot melt adhesives harden very quickly
- Joints bonded with hot melt adhesives can be loosened again by heating (exception: PUR hot melt adhesives)
- Rapid adhesives are not moisture-resistant (Exception: PUR hot melt adhesives)

Processing instructions

- The temperature of the adhesive must remain hot until the parts are completely pressed together. If the adhesive cools down beforehand the bond will not hold.
- The melting temperature must correspond exactly to the specifications of the adhesive manufacturer. Melting temperatures that are too high decompose («burn») the adhesive.

Q27. Explain the following:

(a) Compact panels

(b) Edge materials

Ans. a) Compact panels can be installed independently without a carrier panel and have a decorative layer on both sides. HPL boards, According to EN 438, 2mm thick are considered compact panels and are available in all qualities. In this way, a hygienically tight, easy-to-clean and versatile plate with closed cutting edges is available. Compact panels are used both indoors and outdoors and are available in thicknesses from 2 to 30mm

Area of application interior

- Hygiene, hospital and laboratory facilities
- bathroom equipment
- shop fittings
- Interior lift panels
- table tops

Quality characteristics

- Self-supporting function, however depending on the size and thickness limited
- flame retardant
- high impact, impact and abrasion resistance
- heat resistant
- easy to clean
- Chemically resistant and hygienically sealed surface.

Ans: b) Edge materials serve to coat the narrow surfaces of chipboard, which represent a wide range of applications in the furniture industry. All cut edges on the fronts and on the body are covered with edge materials. This involves locking the furniture components to protect them from environmental influences such as, for example, dirt, water ingress or impact loads, etc. In addition, modern edging materials guarantee optimal design options for the piece of furniture due to their variety of materials and designs. Living spaces are becoming more and more individual, every detail is important. The narrow surface and edge as a design element are becoming increasingly important.

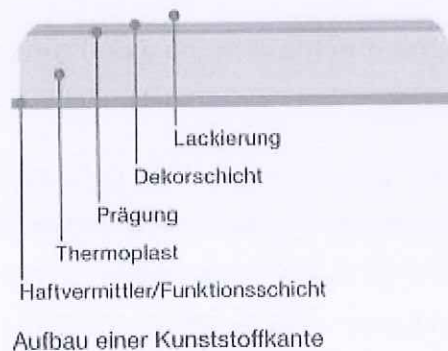

Fig: Construction of a plastic edge

28) Define following:

a) Plastic films

b) Bonded abrasive

Ans: a) Many different plastic films made of different materials are available on the market, such as. B. Carrying bags, construction foils, vapor barriers and brakes as well as roof seals

etc. Foils are 0.2 to 2mm thick, flexible plastic sheets. The printed PVC foils are of particular importance for the carpenter.

PVC films

This plastomeric plastic is heated and in a drawing and Embossing process (calendering process) to thin, flexible foils rolls. Depending on the use, these foils have different thicknesses and different degrees of flatness. Most are made of the same material

throughout. However, there are foils with reinforcements made of paper and fabric etc. in order to increase the adhesion of the coating and / or the resistance.

Application

- in series furniture construction
- in interior fittings for doors
- for edges for coated workpieces

Ans: b) A bonded abrasive is composed of an abrasive material contained within a matrix, although very fine aluminium oxide abrasive may comprise sintered material. This matrix is called a binder and is often a clay, a resin, a glass or a rubber. This mixture of binder and abrasive is typically shaped into blocks, sticks, or wheels. The most common abrasive used is aluminium oxide. Also common are silicon carbide, tungsten carbide and garnet. Another examples of bonded abrasive is grinding wheel.

Section – C

05X10 = 50 Marks

29) Explain the storage of Water content in the wood with diagram.

Ans. Water content of the wood

Wood can contain water in two different ways. If the cell walls are saturated with water, the cell cavities fill with water. This water is called free or capillary water. The proportion of this unbound water is usually very high, but is relatively easy to remove. The water that is bound in the cell walls is called bound water. This is difficult to remove, and this explains the drying speed as the degree of dryness of the wood increases. The area in which there is no free water in the wood is called the fiber saturation area. Depending on the type of wood, it is between 22 and 35% wood moisture.

When moisture is absorbed or released below this area, the wood swells or shrinks, while changes in wood moisture above the fiber saturation area cause changes in shape only to a very small extent.

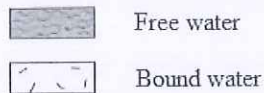
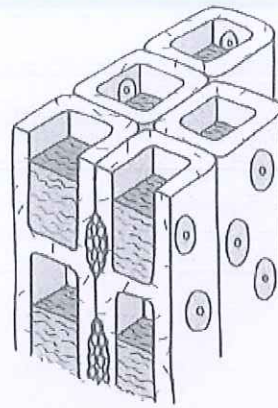

Schematic representation:
free and bound water in the wood

Q 30. Explain the bleaching and pickling processes used for changing the wood colour.

Ans.

Bleaching

Today hydrogen peroxide is mostly used as a bleach. 5 to 10% ammonia spirit is added to the amount of hydrogen peroxide and then diluted with water to the desired bleaching effect. The more concentrated you work, the faster the solution begins to "boil". After boiling, the bleaching solution is ineffective and must be disposed of. By adding ammonia spirit, the hydrogen peroxide solution quickly breaks down into oxygen and water. The released oxygen causes the wood to bleach.

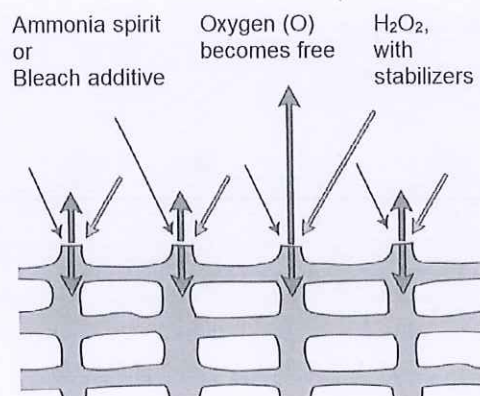

Caution

- Protective measures: Wear gloves, safety glasses and headgear. The bleaching solution attacks metal parts and thus causes discoloration in the wood
- Equipment must be washed out well, as rags, sponges and brushes soaked with bleaching solution can ignite themselves
- The used rags must be kept in non-flammable containers in non-flammable places

After bleaching, allow a drying time of at least 24 hours. If staining is carried out after bleaching, a drying time of 48 hours should be planned. The bleached areas must then be washed with warm water so that the remaining bleach residues can be removed safely. Bleach residues can otherwise lead to cracks or blisters in the lacquer layer and to bleaching.

Pickling

Disambiguation: The word "stain" was originally used to refer to colorations that were made with metal salts or ammonia. These reacted with the ingredients of the woods.

Later, dyes dissolved in solvents were added, which were assigned to the word "dye". The development increasingly produced different dyes and pigments, which in turn were dissolved in different solvents and achieved different effects. At the same time, the original stains were used less and less. However, the name "stain" and the activity "stain" are firmly anchored in

everyday professional life, even if these terms can no longer be clearly assigned from a technical point of view using the methods that are common today. The two processes of the chemical reaction and the physical setting process usually take place in combination in modern products.

Pickling with dissolved dyes: Stains with dissolved dyes penetrate deeper into the wood. They convey "depth" to the pickling pattern. Water and a mixture of different solvents are suitable as solvents.

- Water stain with dissolved dyes
- Solvent stain with dissolved dyes

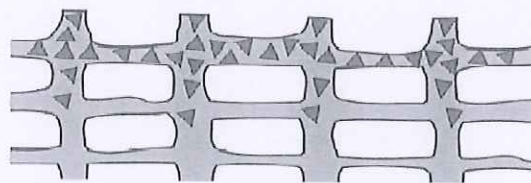

▲▲ Color substance on the cellulose in the wood

Pickling with undissolved dyes: Due to the size of the undissolved dyes, these stains tend to lie on the wood surface. The penetration is inhibited, the dyes therefore have a covering and balancing effect.

- Water stain with undissolved dyes
- Solvent stain with undissolved dyes

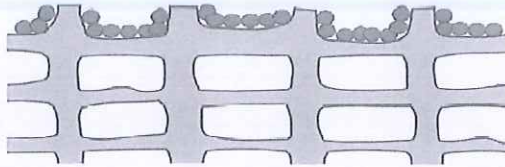

 Color pigments

Q31. Write the instructions for veneer storage in detail.

Ans. Veneer Storage

Veneers are expensive and easily vulnerable if stored improperly. Therefore, the following instructions for storage must be observed:

- Veneers must be stored in dark or darkened rooms or covered with cloths (risk of yellowing under the influence of light). UV rays cause a change in the wood component lignin, which leads to yellowing of the wood.
- Veneers are very brittle when completely dry. The storage climate should therefore correspond to a wood moisture content of 8 to 10% (relative air humidity of 65 to 75%, i.e. in unheated rooms).
- The climate in the camp should remain as constant as possible. Fluctuations in humidity and temperature cause the veneers to shrink and swell, which can lead to cracking.
- Veneers, separated by type of wood, must be stored on racks. Repositioning the veneers too often leads to cracks.
- Newly purchased veneers are to be entered on the inventory list, used veneers are debited.

Q32. Explain the processing of HP laminate.

Ans: The processing involves following steps:

Storage

The plates should be protected from moisture, as moisture causes swelling and consequently leads to a long acclimatization time in the workshop

- The optimal indoor climate is 18 to 23 ° C and 40 to 65% relative humidity
- To prevent scratches, the decor side should be on the decor side be stored
- The protective film should only be removed during final assembly
- The panels must lie flat and over their entire surface. If possible plate or lying in an inclined position must be covered to prevent pollution or harmful light to prevent.

Air conditioning

Before processing, core and laminate boards should be stored in the same room for three to ten days. The different shrinkage mass of the carrier and the laminate boards require this, since otherwise stresses arise and curved workpieces could result. When gluing, care must be taken that all materials are matched to the climate at the place of use, so that the workpiece is exposed to the smallest possible climate fluctuations.

Transport

- Transport individual panels hanging or rolled up with the decorative side inwards. Attention: with the smallest notches in the edge of the panel there is a great risk of tearing.
- In the case of individual deliveries, the plates are often rolled in a box box packed. During the cold season the material is to acclimatize to the indoor climate before unpacking it can be.

Edge cleanliness

Since laminate sheets that have not yet been glued are relatively brittle, the following basic requirements apply when cutting cleanliness: on the one hand, a very sleek carbide or diamond-tipped tool is to be used; the cut edge, which often triggers larger and deeper cracks and breakouts during further processing.

Q33) Explain major characteristics of Laminate.

Ans.

1. HPL boards are insensitive to all normal household chemicals.
2. They are heat-resistant up to about 150 ° C, for short-term exposure in dry heat.
3. They are water resistant. Standing wet under parked However, objects can stain.
4. The change in shape in the longitudinal and transverse directions is less different. The decisive factor is the direction of the paper, which is usually identical to the grinding direction on the back of the plate. The shrinkage mass in the longitudinal direction is max. 2% o and in the transverse direction max. 4% o. This depends on the prevailing indoor climate.
5. HPL boards have good abrasion resistance, which however Normal HPL sheets can only be bent to a limited extent. For tight Radii are available in postforming plates.
6. The HPL boards are hard and brittle, so they are very cracked and sensitive to impact.



School of Woodworking Skills

Session: 2020-21 (Summer / Winter Semester)

B. Voc, 5th Semester,

End-Sem. Examination (Make-up)

Course Code: ~~SET505~~ SCS1505

Time: 3 Hours

Course Name: Advance Carpenter Mathematics

Max. Marks: 100

Instruction: calculator permitted.

Section – A

20X01 = 20 Marks

Q. 1 Which one of the following is used for measuring the central tendency of data:

- a) Scale b) Population c) Median d) None of these.

Q.2 The mixture of a number of gases by volume in the air is known as

- a) Dry air b) Moist air c) Saturated air d) None of these.

Q.3 The ratio of the actual specific humidity to the specific humidity when the air is saturated at the same dry bulb temperature is called

- (a) Humidity ratio (b) Relative humidity (c) Absolute humidity (d) Degree of saturation

Q.4 The moisture content of wood product generally lies between:

- (a) 8-25% (b) 20-45% (c) 60-80% (d) Depends on climatic conditions

Q.5 The oak wood has a mass of 134 kg and a volume of 194 dm³ What is the density?

- (a) 1.44 kg/dm³ (b) 0.69 kg/dm³ (c) 0.89 kg/dm³ (d) 1.34 kg/dm³

Q.6 Which of the following is not used for transmitting power:

- a) Belt drive b) Chain drive c) Gear drive d) Electric Motor.

Q.7 A moulder motor makes 2920 rpm. The working shaft has a pulley of 156mm diameter and should run at 4500 rpm. How big does the pulley on the engine have to be?

- a) 241.41 b) 156.23 c) 141.46 d) 200.21

Q.8 Power is transmitted by belt is dependent on

- a) Velocity b) Tension c) Contact of pulley and belt d) All of these

Q.9 EOQ is

- (a) Enterprise order quantity (b) Enterprise order quality (c) Economic order quantity (d) Economic order quality

Q.10 Total capital investment refers to

- a) Total saving b) Money invested c) Total earnings d) None

Q.11 Power transmitted from belt drive is given by

- a) Torque × Force b) Torque × Tension c) Torque × Speed d) Tension × Mass



BHARTIYA SKILL DEVELOPMENT UNIVERSITY

Q.12 The prediction of future value of product is called as

- a) JIT b) Scheduling c) Forecasting d) None of the above.

Q.13 A circular saw blade has a diameter of 400mm and a speed of 3000 1 / min. How big is its cutting speed?

- a) 62.8 m/s b) 226 m/s c) 62.8 mm/s d) 226 mm/s

Q.14 Which of following is a power transmitting device

- (a) Engine b) Electric motor c) Gear d) None of these

Q.15 The electric energy can be converted to mechanical energy with the help of

- a) Engine b) Turbine c) Electric motor d) Belt drive

Q.16 A planer shaft runs at 4200 rpm and has 4 knives. How big is the step when the feed is 16m / min?

- a) 0.95mm b) 0.88 mm c) 0.16 mm d) 0.70 mm

Q.17 The science of study of the thermodynamic properties of a mixture of dry air and water vapour in the atmosphere is called

- a) Refrigeration b) Air Conditioning c) Psychometric d) None of these

Q.18 JIT stands for

- a) Just in time b) Joint information technology c) Japan instant technology d) None of these

Q.19 Wet bulb temperature is the temperature of air recorded by a thermometer, when

- (a) it is not affected by the moisture present in the air
(b) it bulb is surrounded by a wet cloth exposed to the air
(c) the moisture present in it begins to condense
(d) none of the above

Q.20 The specific humidity is the mass of water vapour present in

- (a) one cubic meter of wet air
(b) one cubic meter of dry air
(c) one kg of wet air
(d) one kg of dry air

Section – B

06X05 = 30 Marks

(Attempt any 06 questions out of 08 questions)

Q.21 Write short notes on: a) Material Requirement Planning b) Specific and Relative humidity.

Q.22 What are the principles of Just In Time techniques?



BHARTIYA SKILL DEVELOPMENT UNIVERSITY

Q.23 Air at a temperature of 85°C , contains an absolute humidity of 210 g/m^3 . what is the relative humidity of air? (Maximum humidity at 85°C is 353 g/m^3)

Q.24 The motor of a circular saw runs at 1460 rpm. The engine pulley has a diameter of 180 mm. The diameter of the pulley at the circular saw is 150 mm. a) What speed does the circular saw shaft reach? b) What is the drive ratio?

Q.25 In a machine, the drive motor has a pulley with a diameter of 220 mm. The speed is specified at 1480 rpm. How big must the pulley be on the working shaft if it is to run at 2680 rpm?

Q.26 Two pulleys with the diameters 280mm and 160mm are connected by a plastic flat belt. The larger, driving disc has a speed of 2980. How many revolutions does the smaller, driven disk make per minute? (Without considering a belt slip)

Q.27 The following table gives the height of 350 men. Calculate the mean height of the group.

Height in cm	No of persons
159	1
161	2
163	9
165	48
167	131
169	102
171	40
173	17

Q.28 Define the terms in the context of Production, Planning and control: a) Scheduling b) Dispatching.

Section – C

05X10 = 50 Marks

Q.29 Explain briefly any two major influence of moisture content in the wood product.

Q.30 Explain the advantages and disadvantage of Just in Time technique.

Q.31 Find the missing frequency from the missing data. If the average marks is 16.82.

Marks	Frequency
-------	-----------

0-5	10
5-10	12
10-15	16
15-20	?
20-25	14
25-30	10
30-35	8

Q.32 Compare belt, chain and gear drive used for power transmission.

Q.33 An engine run at 150 rpm drives a line shaft by means of a belt. The engine pulley is 750mm diameter and pulley of line shaft 450 mm. A 900 mm diameter pulley on a line shaft drives a 150 mm diameter pulley keyed to dynamo shaft. Find the speed of dynamo shaft. When 1) there is no slip 2) there is slip of 2% at each drive



School of _____

Session: 2020-21 (Summer / Winter Semester)

B. Voc. / M. Voc. Program, 1st / 3rd / 5th Semester,

End-Sem. Examination

Course Code: SC1505

Time: 3 Hours

Course Name: Advance Carpenter Mathematics

Max. Marks: 100

Instruction: (if any)

Answer Key

Section – A

20X01 = 20 Marks

1) Which one of the following is used for measuring the central tendency of data:

- a) Scale b) Population c) Median d) None of these.

2) The mixture of a number of gases by volume in the air is known as

- a) Dry air b) Moist air c) Saturated air d) None of these.

3) The ratio of the actual specific humidity to the specific humidity when the air is saturated at the same dry bulb temperature is called

- (a) Humidity ratio (b) Relative humidity (c) Absolute humidity (d) Degree of saturation

4) The moisture content of wood product generally lies between:

- (a) 8-25% (b) 20-45% (c) 60-80% (d) Depends on climatic conditions

5) The oak wood has a mass of 134 kg and a volume of 194 dm³ What is the density?

- (a) 1.44 kg/dm³ (b) 0.69 kg/dm³ (c) 0.89 kg/dm³ (d) 1.34 kg/dm³

6) Which of the following is not used for transmitting power:

- a) Belt drive b) Chain drive c) Gear drive d) Electric Motor.

7) A moulder motor makes 2920 rpm. The working shaft has a pulley of 156mm diameter and should run at 4500 rpm. How big does the pulley on the engine have to be?

- a) 241.41 b) 156.23 c) 141.46 d) 200.21

8) Power is transmitted by belt is dependent on

- a) Velocity b) Tension c) Contact of pulley and belt d) All of these

9)) EOQ is

- (a) Enterprise order quantity (b) Enterprise order quality (c) Economic order quantity (d) Economic order quality

10) Total capital investment refers to

- a) Total saving b) Money invested c) Total earnings d) None

11) Power transmitted from belt drive is given by

- a) Torque \times Force b) Torque \times Tension c) Torque \times Speed d) Tension \times Mass

12) The prediction of future value of product is called as

- a) JIT b) Scheduling c) Forecasting d) None of the above.

13) A circular saw blade has a diameter of 400mm and a speed of 3000 1 / min. How big is its cutting speed?

- a) 62.8 m/s b) 226 m/s c) 62.8 mm/s d) 226 mm/s

14) Which of following is a power transmitting device

- (a) Engine b) Electric motor c) Gear d) None of these

15) The electric energy can be converted to mechanical energy with the help of

- a) Engine b) Turbine c) Electric motor d) Belt drive

16) A planer shaft runs at 4200 rpm and has 4 knives. How big is the step when the feed is 16m / min?

- a) 0.95mm b) 0.88 mm c) 0.16 mm d) 0.70 mm

17) The science of study of the thermodynamic properties of a mixture of dry air and water vapour in the atmosphere is called

- a) Refrigeration b) Air Conditioning c) Psychrometry d) None of these

18) JIT stands for

- a) Just in time b) Joint information technology c) Japan instant technology d) None of these

19) Wet bulb temperature is the temperature of air recorded by a thermometer, when

- (a) it is not affected by the moisture present in the air
(b) it bulb is surrounded by a wet cloth exposed to the air
(c) the moisture present in it begins to condense
(d) none of the above

20) The specific humidity is the mass of water vapour present in

- (a) one cubic meter of wet air
(b) one cubic meter of dry air
(c) one kg of wet air
(d) one kg of dry air

Section – B

06X05 = 30 Marks

(Attempt any 06 questions out of 08 questions)

21) Write short notes on: a) Material Requirement Planning b) Specific and Relative humidity.

Solution:

- (a) Material Requirements Planning is primarily related to the inventory of raw materials and components which are required to produce the products in a facility. Their demand is usually termed as secondary demand that totally depends upon the demand of finished product. MRP is a time phased priority-planning technique that estimates material requirements and schedules supply to meet demand across all products and parts in one or more plants. Now- a- days, information technology plays a major role in designing and implementing Material Requirements Planning systems and processes as it provides information about manufacturing needs (linked with customer demand) as well as information about inventory levels.
- (b) Specific Humidity: It is the mass of water vapour present in 1 kg of dry air, and is generally expressed in terms of gram per kg of dry air (g/kg of dry air). It is also called specific humidity or humidity ratio. Relative humidity: It is the ratio of actual mass of water vapour in a given volume of moist air to the mass of water vapour in the same volume of saturated air at the same temperature and pressure. It is briefly written as $RH(\phi)$.

22) What are the principles of Just In Time techniques?

Solution:

- a) Elimination of waste: Any activity that does not add value to the product or service in the eyes of the customer is a waste. Poor product design such as the inclusion of fancy functions not required by the customer is a waste. A product design causing difficulty in manufacturing is a waste. Standardization reduces the planning and control efforts.
- b) Waste of overproduction: Overproduction is the production of goods more than what are immediately needed. Overproduction causes extra material handling, quality problems, and unnecessary inventories.
- c) Waste of waiting: A material waiting in queue is a waste. An operator waiting for material or instruction and having no productive work to do is a waste.
- d) Waste of movement: Poor plant layout results in materials having to be moved extra distances and cause unnecessary material handling costs. Work centers should be close to each other in order to reduce the move distance.
- e) Waste of motion: Improper methods of performing tasks by the operators cause wasted motions. Reaching far for materials or machine buttons is a waste of motion. Searching for tools is a waste of motion. Any activity that does not add value to the products should be eliminated. Bad layout or training causes waste of motion.
- f) Waste of process itself: Bad process design is a waste. For example, wrong type or size of machines, wrong tools, and wrong fixtures are wastes.

23) Air at a temperature of 85°C, contains an absolute humidity of 210 g/m³. what is the relative humidity of air?
(Maximum humidity at 85C is 353 g/m³)

Solution:

$$\varphi_{rel} = \frac{\varphi_{abs} \times 100\%}{\varphi_{Max}}$$

$$\frac{100\% \cdot 210 \text{ g/m}^3}{353 \text{ g/m}^3} = \underline{\underline{59.49\%}}$$

Ans: 59.49 %

24) The motor of a circular saw runs at 1460 rpm. The engine pulley has a diameter of 180 mm. The diameter of the pulley at the circular saw is 150 mm. a) What speed does the circular saw shaft reach? b) What is the drive ratio?

Solution:

$$n_2 = \frac{d_1 n_1}{d_2} = \frac{180 \times 1460}{150} = 240.41$$

$$i = \frac{n_2}{n_1} = \frac{2500}{1460} = 1.714$$

Ans: 240.41 rpm and 1.714

25) In a machine, the drive motor has a pulley with a diameter of 220 mm. The speed is specified at 1480 rpm. How big must the pulley be on the working shaft if it is to run at 2680 rpm?

Solution:

$$d_2 = \frac{d_1 n_1}{n_2}$$

Ans: 121.49 mm

26) Two pulleys with the diameters 280mm and 160mm are connected by a plastic flat belt. The larger, driving disc has a speed of 2980. How many revolutions does the smaller, driven disk make per minute? (Without considering a belt slip)

Solution:

$$n_2 = \frac{d_1 \cdot n_1}{d_2} = \frac{2980 \frac{1}{\text{min}} \cdot 280\text{mm}}{160\text{mm}} =$$

Ans: 5215 rpm

27) The following table gives the height of 350 men. Calculate the mean height of the group.

Height in cm	No of persons
159	1
161	2
163	9
165	48
167	131
169	102
171	40
173	17

Solution:

Height in cm (<i>x</i>)	No of persons <i>f</i>	Deviation from assumed mean 167 <i>dx</i>	Step Deviation <i>dx</i>	Total deviation (<i>fdx</i>)
159	1	-8	-4	-4
161	2	-6	-3	-6
163	9	-4	-2	-18
165	48	-2	-1	-48

167	131	0	0	0
169	102	2	1	102
171	40	4	2	80
173	17	6	3	51

Ans : $X = 167 + \left(\frac{157}{350} \times 2\right) = 167.8$

28) Define the terms in the context of Production, Planning and control: a) Scheduling b) Dispatching.

Ans: a) scheduling ensure that parts and sub-assemblies and finished goods are completed as per required delivery dates. It provides a timetable for manufacturing activities.

Purpose of scheduling:

- To prevent unbalance use of time among work and centers and department.
- To utilize labour such a way that output is produced within established lead time or cycle time so as to deliver the products on time and complete production in minimum total cost.

Ans: b) This is concerned with the execution of the planning functions. It gives necessary authority to start a particular work which has already planned under routing and scheduling functions. Dispatching is release of orders and instructions for starting of production in accordance with routing sheet and scheduling charts.

Section – C

05X10 = 50 Marks

05 essay type questions, each question carries 10 marks.

29) Explain briefly any two major influence of moisture content in the wood product.

Solution: Wood is a material that continually absorbs or releases moisture until it reaches a balance with its surroundings. In normal use the moisture content of wood varies between 8% and 25% by weight, depending on the relative humidity of the air. On the other hand, an excess of moisture in wood can cause other problems, including, but not limited to: Preventing adhesives from making a secure bond (Less strength) and Shrinkage as the excess moisture leaves the wood:

Shrinkage occurs as moisture content decreases, while swelling takes place when it increases. Volume change is not equal in all directions. The greatest dimensional change occurs in a direction tangential to the growth rings. Shrinkage from the pith outwards, or radially, is usually considerably less than tangential shrinkage, while longitudinal (along the grain) shrinkage is so slight as to be usually neglected. The longitudinal shrinkage is 0.1% to 0.3%, in contrast to transverse shrinkages, which is

2% to 10%. Tangential shrinkage is often about twice as great as in the radial direction, although in some species it is as much as five times as great. The shrinkage is about 5% to 10% in the tangential direction and about 2% to 6% in the radial direction.

30) Explain the advantages and disadvantage of Just in Time technique.

Ans: Companies like to use JIT as it is seen as a more cost efficient method of holding stock. Its purpose is to minimize the amount of goods you hold at any one time, and this has numerous advantages:

- Less space needed: With a faster turnaround of stock, you don't need as much warehouse or storage space to store goods. This reduces the amount of storage an organization needs to rent or buy, freeing up funds for other parts of the business.
- Waste reduction: A faster turnaround of stock prevents goods becoming damaged or obsolete while sitting in storage, reducing waste. This again saves money by preventing investment in unnecessary stock, and reducing the need to replace old stock.
- Smaller investments: JIT inventory management is ideal for smaller companies that don't have the funds available to purchase huge amounts of stock at once. Ordering stock as and when it's needed helps to maintain a healthy cash flow.

31) Find the missing frequency from the missing data. If the average marks is 16.82.

Marks	Frequency
0-5	10
5-10	12
10-15	16
15-20	?
20-25	14
25-30	10
30-35	8

Solution:

Marks	Mid Value	Frequency (f)	Step deviation (dx)	fdx
0-5	2.5	10	-3	-30
5-10	7.5	12	-2	-24
10-15	12.5	16	-1	16

15-20	17.5	f	0	0
20-25	22.5	14	1	14
25-30	27.5	10	2	20
30-35	32.5	8	3	24
Total		70+f		-12

$$16.82 = 17.5 + \left(\frac{-12}{70+f} \times 5 \right)$$

Solving the equation for "f"

Ans: Missing data for the marks: 18

32) Compare belt, chain and gear drive used for power transmission.

BELT DRIVE	CHAIN DRIVE	GEAR DRIVE
Main element Pulleys, belt	Main element Sprockets, chain	Main element Gears
Slip may occur	No-slip	No-slip
Suitability For the large center distance	Suitability For the moderate center distance	Suitability For the short center distance
Large Space requires	Moderate Space requires	Less Space requires
Simplest Design, manufacturing, complexity	Simplest Design, manufacturing, complexity	Complicated Design, manufacturing, complexity
Failure of the belt does not cause the further damage of machine	Failure of a chain may not seriously damage the machine.	Failure of gear may cause serious break down in the machine.
Less Life	Moderate Life	Long Life
Lubrication Not required	Lubrication required	Requires proper lubrication
Less Installation cost	Moderate Installation cost	More Installation cost
Used For low-velocity ratio	Used For moderate velocity ratio	Used For high velocity ratio



School of Woodworking Skills
Session: 2020-21 (Summer Semester)
B. Voc. Program, 1st Semester,
End-Sem. Examination (Make - up)

Course Code: SCS1107

Time: 3 Hours

Course Name: Open Elective – I (DIY Furniture)

Max. Marks: 100

Instruction:

1. Answer all question from section A, each question carries one mark.
2. Answer all question from section B, each question carries five marks.
3. Answer all question from section C, each question carries ten marks.

Section – A

20X01 = 20 Marks

Q.1 Which one of the following is used to make particle boards?

- | | |
|---------------|-------------------|
| (a) Wood dust | (b) Wood chips |
| (c) PVC | (d) None of these |

Q.2 Which one of the following is not used to make tenon in Hand skill?

- | | |
|-------------------|-------------------|
| (a) Handy machine | (b) Hand saw |
| (c) Chisel | (d) Mortise gauge |

Q.3 Which one of the following is used to check 90°?

- | | |
|-------------------|----------------|
| (a) Marking gauge | (b) Try square |
| (c) Chisel | (d) Hammer |

Q.4 Which one of the following is use to transfer angle from one piece to another?

- | | |
|------------------|-------------------|
| (a)Try square | (b) Marking gauge |
| (c) Double meter | (d) Sliding bevel |

Q.5 Which one of the following tool is used to sharp chisel?

- | | |
|-------------------|----------------------|
| (a) Flat file | (b) Sharpening stone |
| (c) Both of these | (d) None of these |

Q.6 Which one of the following is not a part of wood structure?

- | | |
|------------|----------------|
| (a) leaves | (b) Bark |
| (c) Pith | (d) Heart wood |

Q.7 Which one of the following is an example of fiber board?

- | | |
|--------------------|----------------|
| (a) Particle board | (b) Solid Wood |
| (c) MDF | (d) Ply board |

Q.8 Which one of the following is the smallest measurement mark on a roll meter?

- | | |
|----------|----------------|
| (a) Foot | (b) Meter |
| (c) Inch | (d) Millimeter |

Q.9 What should you do in case you have damaged a tool while working.

- (a) Report to the trainer
- (b) Leave it unattended
- (c) Ignore the tool
- (d) None of the above

Q.10 Which one of the following is the soft wood.?

- (a) Pine
- (b) Teak
- (c) Acacia
- (d) Sal

Q.11 Which one of the following is the hard wood?

- (a) Pine
- (b) Particle Board
- (c) Steam Beach
- (d) None of these

Q.12 Which one of the following wood is used to make biscuits?

- (a) Pine wood
- (b) Steam Beach
- (c) Both of these
- (d) None of these

Q.13 Which one of the following tool is used to mark lines of different angle.

- (a) Try square
- (b) Marking gauge
- (c) Caliper
- (d) Bevel angle

Q.14 One Centimeter equals to:

- (a) 1mm
- (b) 10mm
- (c) 100mm
- (d) 0.1mm

Q.15 Which one of the following is used to make MDF boards?

- (a) Wood dust
- (b) Wood chips
- (c) PVC
- (d) None of these

Q.16 Which one of the following pencil is used for light measurement during transferring measurement on work piece?

- (a) 0.7 mm
- (b) 0.5 mm
- (c) 0.1 mm
- (d) 2 mm

Q.17 Which one of the following is a planning tool?

- (a) Jack planner
- (b) screw driver
- (c) Japanese pull saw
- (d) none of them

Q.18 Which one of the following is a marking tool?

- (a) Manual hand planer
- (b) Perforated chisel
- (c) Try square
- (d) None of them

Q.19 Which one of the following saw is used to make half lap joint?

- (a) Indian saw
- (b) Japanese saw
- (c) Coping saw
- (d) All of the above

Q.20 Which one of the following is not the application of try square?

- (a) Used to make straight line
- (b) Used to check surface flatness
- (c) Used to make curved lines
- (d) All of the above

Section – B

06X05 = 30 Marks

- Q.21 Write a short description on wood.
- Q.22 Write any five differences between soft wood and hard wood.
- Q.23 Explain dovetail joint for box construction.
- Q.24 Define any four measuring tools in woodworking.
- Q.25 Define glued profile joint with sketch and write down its two advantages.
- Q.26 Draw any six marking Symbols and write about their scopes.
- Q.27 What is a carpenter triangle and explain its application with sketch?
- Q.28 Explain the need of joinery in woodworking.

Section – C

05X10 = 50 Marks

- Q.29 What kind of safety precautions should be kept in mind while working with wood working workshop.
- Q.30 Discuss the structure of wood construction with suitable diagram.
- Q.31 Explain tenon and mortice joint with their neat sketch and also mention their two advantages and two disadvantages.
- Q.32 Explain corner bridle joint with their neat sketch and also mention their two advantages and two disadvantages.
- Q.33 Write short notes on:
- (a) Chisels (b) Hammer (c) Hand saw (d) Files (e) Jack Planer

School of Woodworking Skills
Session: 2020-21 (Summer Semester)
B. Voc. Program, 1st Semester,
End-Sem. Examination

Course Code: SCS1107

Time: 3 Hours

Course Name: Open Elective – I (DIY Furniture)

Max. Marks: 100

Instruction:

1. Answer all question from section A, each question carries one mark.
2. Answer all question from section B, each question carries five marks.
3. Answer all question from section C, each question carries ten marks.

Section – A

20X01 = 20 Marks

Q.1 Which one of the following is used to make particle boards?

- (a) Wood dust (b) Wood chips
(c) PVC (d) None of these (b)

Q.2 Which one of the following is not used to make tenon in Hand skill?

- (a) Handy machine (b) Hand saw
(c) Chisel (d) Mortise gauge (a)

Q.3 Which one of the following is used to check 90°?

- (a) Marking gauge (b) Try square
(c) Chisel (d) Hammer (b)

Q.4 Which one of the following is use to transfer angle from one piece to another?

- (a) Try square (b) Marking gauge
(c) Double meter (d) Sliding bevel (d)

Q.5 Which one of the following tool is used to sharp chisel?

- (a) Flat file (b) Sharpening stone
(c) Both of these (d) None of these (b)

Q.6 Which one of the following is not a part of wood structure?

- (a) leaves (b) Bark
(c) Pith (d) Heart wood (a)

Q.7 Which one of the following is an example of fiber board?

- (a) Particle board (b) Solid Wood
(c) MDF (d) Ply board (a)

Q.8 Which one of the following is the smallest measurement mark on a roll meter?

- (a) Foot (b) Meter
(c) Inch (d) Millimeter (d)

Q.9 What should you do in case you have damaged a tool while working.



BHARTIYA SKILL DEVELOPMENT UNIVERSITY

- (a) Report to the trainer (b) Leave it unattended
(c) Ignore the tool (d) None of the above (a)
- Q.10 Which one of the following is the soft wood? (a) Pine (b) Teak
(c) Acacia (d) Sal (a)
- Q.11 Which one of the following is the hard wood? (a) Pine (b) Particle Board
(c) Steam Beach (d) None of these (c)
- Q.12 Which one of the following wood is used to make biscuits? (a) Pine wood (b) Steam Beach
(c) Both of these (d) None of these (b)
- Q.13 Which one of the following tool is used to mark lines of different angle. (a) Try square (b) Marking gauge
(c) Caliper (d) Bevel angle (d)
- Q.14 One Centimeter equals to: (a) 1mm (b) 10mm
(c) 100mm (d) 0.1mm (b)
- Q.15 Which one of the following is used to make MDF boards? (a) Wood dust (b) Wood chips
(c) PVC (d) None of these (a)
- Q.16 Which one of the following pencil is used for light measurement during transferring measurement on work piece? (a) 0.7 mm (b) 0.5 mm
(c) 0.1 mm (d) 2 mm (b)
- Q.17 Which one of the following is a planning tool? (a) Jack planner (b) screw driver
(c) Japanese pull saw (d) none of them (a)
- Q.18 Which one of the following is a marking tool? (a) Manual hand planer (b) Perforated chisel
(c) Try square (d) None of them (c)
- Q.19 Which one of the following saw is used to make half lap joint? (a) Indian saw (b) Japanese saw
(c) Coping saw (d) All of the above (d)
- Q.20 Which one of the following is not the application of try square? (a) Used to make straight line (b) Used to check surface flatness
(c) Used to make curved lines (d) All of the above (c)

Section – B

06X05 = 30 Marks

Q.21 Write a short description on wood.

Ans. Wood is the main substance in trees. Wood is used to make buildings and furniture, and also for art. Paper is made from wood fibres. Wood is a renewable resource although it has become scarcer in recent centuries. Wood is very hard to cut, but it is also very strong. A lumberjack is a person who cuts down trees. After a tree falls, the wood in it can be cut into long, straight pieces called lumber. Lumber can then be used to make posts, or put together with nails, screws, or even glue to make wooden frames for other shapes.

Wood comes in many different kinds. Oak, maple (hardwood) and pine and redwood (softwood) are widely used types of wood. Woods are usually divided into softwood (from conifers) and hardwood from flowering plants.

Q.22 Write any five differences between soft wood and hard wood.

Ans.

Characteristics	Softwood	Hardwood
Source	Softwood is collected from conifer trees which are evergreen having needle-shaped leaves. these are generally gymnosperms.	Hardwood is obtained from deciduous trees (loses leaves in autumn). They are basically angiosperms.
Fiber	Less dense, strait fiber is found.	In case of hardwood, the fibers are quite close and dense.
Weight	Lightweight and softer than hardwood.	Heavyweight and harder than softwood.
Colour	Softwood is light in color.	Normally these are dark colored woods.
Example	Pine, Redwood.	Oak, Steam Beech.

Q.23 Explain dovetail joint for box construction.

Ans. A series of 'pins' cut to extend from the end of one board interlock with a series of 'tails' cut into the end of another board. The pins and tails have a trapezoidal shape. Once glued, a wooden dovetail joint requires no mechanical fasteners. Dovetail joints are so named from the shape of the piece which make the joint. This is probably the strongest method for joining two pieces of wood. The strength of the dovetail joint comes from the interlocking of the parts. There is a great variety of forms of dovetail joints.

Advantage – Dovetail joint will be extremely strong and is resistant to pulling apart.

Disadvantage – This type of joint may be too hard for a beginner, as it needs precision cutting.

Q.24 Define any four measuring tools in woodworking.

Ans.

1. Steel Ruler - Steel ruler is suitable for measuring short distances. It measures distances accurately in the range of millimeter.
2. Vernier Caliper - It is mainly used for fine measurements in wood working. They ensure a precise measurement of inside and outside dimension as well as depth.
3. Double Meter - The foldable double meter consists of short strips of wood, plastic or metal which are connected by swivel joint.
4. Roll Meter - They are available in different length and designs. They ensure a measurement of exact length and circular work pieces.

Q.25 Define glued profile joint with sketch and write down its two advantages.

Ans. Glued profile joints contains finger joints, comb joints, box joints. A box joint, is a woodworking joint made by cutting a set of complementary rectangular or angular cuts in two pieces of wood, which are then glued, with filler. To visualize a finger joint simply interlock the fingers of your hands at a ninety-degree angle or parallel; hence the name "finger joint."

Advantage -

- Large gluing surfaces
- Enough strong joint in lateral form.

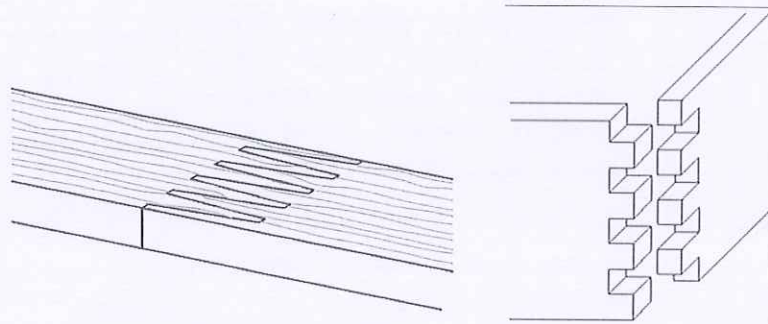

Q.26 Draw any six marking Symbols and write about their scopes.

Ans.

1. **X - Cross** - The scope of this symbol is throughout cut and continuous separation cut.
Example - Cutting off cuts.



2. **Wave Line** - The scope of this symbol is material cutting area.
Example - Overlapping material removal.



3. **Arrow** - The scope of this symbol is limitation of machining operations.
Example - groove, Rebate.



4. **Cross** - The scope of this symbol is Mortise hole.
Example - Hole for tenon and mortise joint.



5. **Number** - The scope of this symbol is Indication of the depth of a mortise hole.

Example - Indication of drilling depth, Indication of groove depth.

42

6. **Hatching** - The scope of this symbol is Material that is partially removed not throughout.

Example - Hatching for notches.

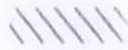

Q.27 What is a carpenter triangle and explain its application with sketch?

Ans. We use symbols to combine work piece together. The symbol that is used to combine is called triangle sign. The aim of drawing symbol is that the individual parts of the work are evaluated at the same time and by each person. Sometimes we use the left part instead of the right part and the top part instead of the bottom because there are several identical pieces of the same size, so we need to number them accordingly and this can be done by making triangle sign. The sign should not be too small. It should be clearly visible. It should be drawn from the bottom to the top and from front to back.

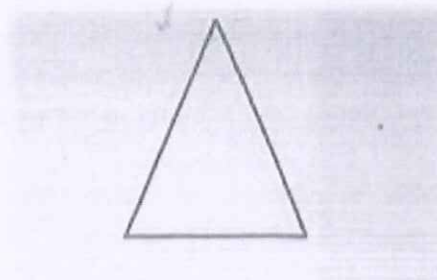

Triangle

Q.28 Explain the need of joinery in woodworking.

Ans. Woodworking joinery is the craft of connecting and securing the separate members of the wooden construction to one another by means of specific cuts on the ends or sides of the members. Woodworking joint is the spot where the two pieces of wooden construction are joined together to form a rigid self-supporting and permanent construction. Woodworking joints can be formed between the edges or between the end and the face, in the direction of the length, at right angles or it may be at an angle, other than a right angle. Various glues or fasteners (nails, screws, bolts etc.) are being used to increase the strength, effectiveness and rigidity of woodworking joints. Since the main purpose of woodworking joints is to join wooden parts together, their construction should be done carefully, so it would not weaken the parts that are joining.

Section – C

05X10 = 50 Marks

Q.29 What kind of safety precautions should be kept in mind while working with wood working workshop.

Ans. The following are general safety procedures that apply to almost every work situation.

- Adhere to instructions.
- Read labels and warnings on containers and tools.
- Follow the manufacturer's recommendations for use and maintenance of a specific tool.
- Pay attention to signs posted in the work area.

Follow the instructor's directions.

- Wear safety glasses in the shop at all times.
- Wear protective gear such as gloves, earplugs, and safety shoes if appropriate.
- Do not wear loose-fitting clothing that could get caught in a moving part.
- Wear a hair net to prevent long hair from getting caught in a tool.
- Keep work areas clean and free of clutter.
- Inspect each tool before using it to make sure it is working properly.
- Tell the instructor about any damaged tool.
- Do not use a tool that is not working properly.
- Return each tool to its proper place of storage.

Q.30 Discuss the structure of wood construction with suitable diagram.

Ans. When you look at the cross section of a trunk, you notice that it is made up of different zones or layers.

- **The Marrow (Pith)** is at the centre of the trunk and is responsible for the tree's heightening.
- **The core (the heartwood)** lies in the inner part of the trunk. It consists of old wood cells that store nutrients. The largest part of the wood used by you as carpenter practice comes from this tree part, since heartwood is more resistant than sapwood. The Core part can have a darker colour than the sapwood. This varies depending on the type of wood.
- **The sapwood (sapwood)** has the task of transporting water and nutrients from the roots to the leaves.
Sapwood is less suitable than heartwood. Sapwood may have a lighter colour than the heartwood. This differs depending on the type of wood.
- **The cambium** is the growth layer of the tree. It is a dilute, sensitive layer.
The cambium is responsible for the production of new wood during the growing season of the tree (spring and summer).
- **The bast** lies under the bark. It transports the nutrient produced in the tree trunk.
- **The bark** is the outermost layer of the tree. Its function is the protection of the tree against extreme temperatures, pests and diseases.
- **The medullary rays** are not a parent layer. They connect the centre of the stem with the various layers of the cells for the transport of water and nutrients.

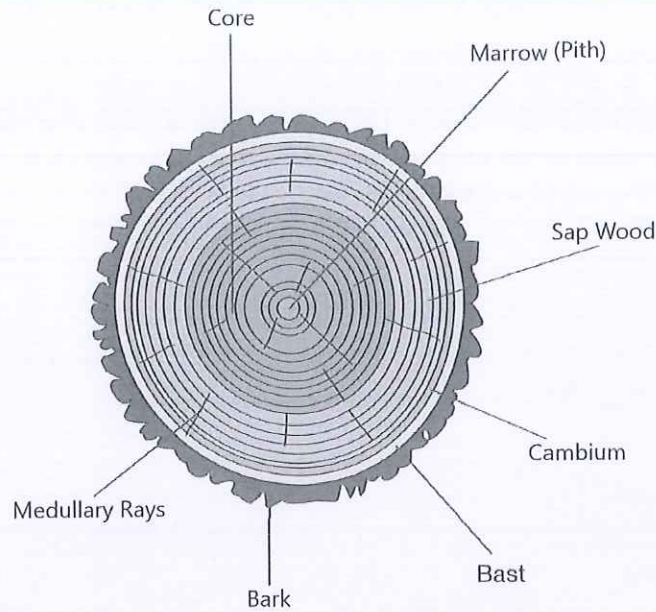

Q.31 Explain tenon and mortise joint with their neat sketch and also mention their two advantages and two disadvantages.

Ans. A mortise and tenon joint is a type of joint that connects two pieces of wood at usually angle of 90° . Mortise and tenon are two components: the mortise hole and the tenon tongue. The tenon is cut to fit the mortise hole exactly and usually has shoulders that seat when the joint fully enters the mortise hole. The joint may be glued, pinned, or wedged to lock it in place.

A mortise and tenon joint is one in which the rectangular end (the tenon) of one piece fits into a rectangular hole (the mortise) of the same size, in the other piece. Mortise and tenon joints are made in a number of different types. The blind mortise and tenon is the most common. It is used extensively in cabinetmaking for joining rails to legs or stiles, and in many other constructions well. When properly designed, proportioned, and well made, mortise and tenon joints are strong and neat in appearance.

Advantage – 1. Very good strength for heavy doors and gates.

2. It is both simple and strong.

Disadvantage – 1. Complex production while mortise hole.

2. Higher accuracy required to produce this joint.

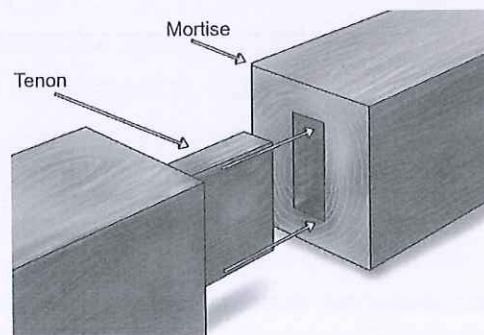

Q.32 Explain corner bridle joint with their neat sketch and also mention their two advantages and two disadvantages.

Ans. A bridle joint is a woodworking joint, similar to a mortise and tenon, in that a tenon is cut on the end of one member and a mortise is cut into the other to accept it. The difference feature is that the tenon and the mortise are cut to the full width of the tenon member. The corner bridle joint joins two members at their respective ends, forming a corner. The bridle

joint is very popular in workbench construction. This joint is very decorative and very stable for window frames.

A bridle joint is similar to a mortise and tenon woodworking joint, though in most circumstances it would not be as strong. It is an open-ended mortise and tenon joint. A bridle joint is quick and easy to make, since most of the waste wood is removed with a saw.

Advantage –

1. Very good strength in compression
2. Simpler alternative to the mortise and tenon joint because of no need for a mortise machine in a narrow frame.

Disadvantage –

1. Outer visibility of joints.
2. If any gap remains in construction, then a mechanical fastener or pin is often required.

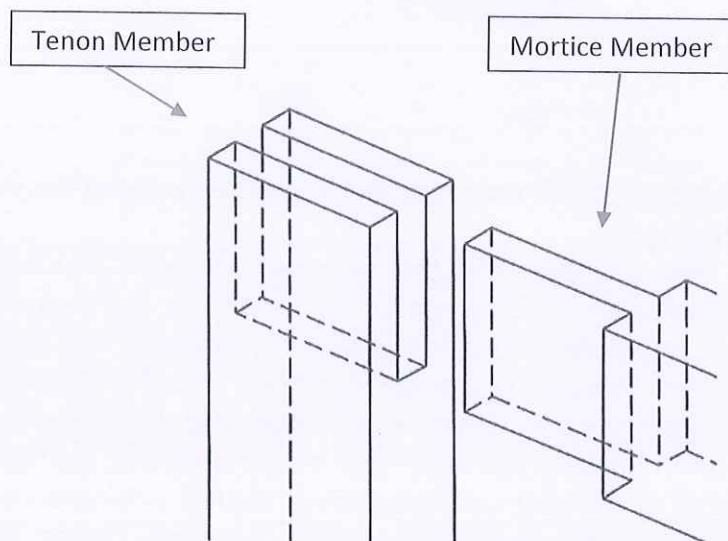

Q 33 Write short notes on:

- (a) Chisels (b) Hammer (c) Hand saw (d) Files (e) Jack Planer

Ans. (a) Chisels - Chisels are tools that can remove thick or thin shavings of wood. We can remove material by the chisel by cutting edge of blade on its end, for flat and carving. The handle is made of plastic and wood or blade of chisel are made of metal with a sharp edge in it. Chiseling use involves forcing the blade into some material to cut it. The driving force may be applied by pushing by hand, or by using a mallet or hammer.

(b) Hammer – A hammer is a tool that delivers a sudden impact to an object. These are hand tools used to drive nails, fit objects. Hammers vary in shape, size, and structure, depending on their purposes. **Application** – Punching, Striking and Pulling.

(c) Hand saw - Hand saw is designed to cut hard and soft wood. Saw is used to make straight cuts across the grain and along the grain of the wood. A hand saw has a long, wide blade which usually cannot be removed from the handle. The teeth of a saw are pointed like a knife and cut on both the forward and backward strokes as per the quality of the blade. Traditionally, hand saws would have either crosscut teeth (for cutting wood across the grain) or rip teeth (for cutting along the grain). Nowadays, most models have teeth that are able to do both. These are often referred to as “universal” or “utility” teeth.



BHARTIYA SKILL DEVELOPMENT UNIVERSITY

(d) Files - Files are useful for forming and smoothing irregular shapes such as curves and cuts. They are classified by shape (triangular, half-round, round, and flat), length (6 in., 8 in., 10 in., and 12 in.), teeth design (single cut and double cut). The Flat Teeth coarseness wood to be filed must be put in a vice or other device to hold it firmly. Files should be held at a slight angle to the work, with filing done from the Heel Face Point edge to the center to avoid splintering the wood.

(e) Jack Planer – This is a hand tool with adjustable blade for smoothing or shaping pieces of wood and by the adjustment of blade we can increase or decrease the chips thickness. A jack planer has sharpening edge for efficient working is the edge is not sharp, then use of sharpening stones to sharp the edge.

