



BHARTIYA SKILL DEVELOPMENT UNIVERSITY

Registration no _____

School of Woodworking Skills

Session: 2021-22 (Summer Semester)

Set A

B. Voc. Program, 3rd Semester,

End Sem. Examination

Code: SCS1301

Time: 2 Hour

Course Name: Advanced Power Tools

Max. Marks: 50

Instruction:

- Answer all questions from section A, each question carries one mark.
- Answer all question from section B, each question carries Four marks.
- Answer all question from section C, each question carries Six marks.

Section A

10X01 = 10 Marks

- Q. 1 Which one of the following machine is used for profile groove Joint?
- (A) Circular Saw (B) Jig Saw
(C) Zeta P2 (D) Lamello Classic X
- Q. 2 Centering Mandrel is an accessory of
- (A) Router (B) Jig Saw.
(C) Circular Saw (D) Both A&C
- Q. 3 In the given option which accessories prevent the kick back in hand circular saw.
- (A) Guide Rail (B) Riving Knife
(C) Side Stops (D) None of these.
- Q. 4 Which one of the following machine uses the accessory suction stub?
- (A) Circular Saw (B) Jig saw
(C) Edge Router (D) Lamello
- Q. 5 Which of the following diameter of cutter used for 4x20 domino?
- (A) 10 mm (B) 4 mm
(C) 8mm (D) 5 mm
- Q. 6 LR 32 system is used in which machine
- (A) Router (B) Jig Saw
(C) Circular Saw (D) Both A&C
- Q. 7 Which one of the following accessories is used with MFS template for making Groove
- (A) Guide Rail (B) Coping Ring
(C) Side Stops (D) None of these.
- Q. 8 Which one of the following accessories is used for tear free cut



BHARTIYA SKILL DEVELOPMENT UNIVERSITY

- (A) Splinter guard (B) Coping Ring
(C) Side Stops (D) None of these.
- Q. 9 Which one of the following accessories is used in LR 32 System
- (A) Centering mandrel (B) Longitudinal Stop
(C) Side Stops (D) All of these.
- Q. 10 Which one of the following is the maximum depth taken in Domino
- (A) 28 (B) 12
(C) 20 (D) None of these.

Section B

04X04 = 16 Marks

- Q. 11 Write short note on Zeta P2 machine?
- Q. 12 What is lamello Classic X? Write down the accessories name of Lamello Classic X.
- Q. 13 Explain the Table router with diagram?
- Q. 14 Draw the diagram of router bit with its parts name.

Section C

04X06 = 24 Marks

- Q. 15 What are the criteria for selection of router bit and what are the material used for router bit ?
- Q. 16 What is LR 32 system? Write down the working procedure of it.
- Q. 17 Explain the pendulum adjustment mechanism of Jig saw.
- Q. 18 Write Down the steps to increase the life of a router bit



BHARTIYA SKILL DEVELOPMENT UNIVERSITY

Answer Key

School of Woodworking Skills

Session: 2021-22 (Summer Semester)

Set A

B. Voc. Program, 3rd Semester,

End Sem. Examination

Code: SCS1301

Time: 2 Hour

Course Name: Advanced Power Tools

Max. Marks: 50

Instruction:

- Answer all questions from section A, each question carries one mark.
- Answer all question from section B, each question carries Four marks.
- Answer all question from section C, each question carries Six marks.

Section A

10X01 = 10 Marks

- Q. 1 Which one of the following machine is used for profile groove Joint?
(A) Circular Saw (B) Jig Saw
(C) Zeta P2 (D) Lamello Classic X Ans. C
- Q. 2 Centering Mandrel is an accessory of
(A) Router (B) Jig Saw
(C) Circular Saw (D) Both A&C Ans. A
- Q. 3 In the given option which accessories prevent the kick back in hand circular saw.
(A) Guide Rail (B) Riving Knife
(C) Side Stops (D) None of these. Ans. B
- Q. 4 Which one of the following machine uses the accessory suction stub?
(A) Circular Saw (B) Jig saw
(C) Edge Router (D) Lamello Ans. D
- Q. 5 Which of the following diameter of cutter used for 4x20 domino?
(A) 10 mm (B) 4 mm
(C) 8mm (D) 5 mm Ans. C
- Q. 6 LR 32 system is used in which machine
(A) Router (B) Jig Saw
(C) Circular Saw (D) Both A&C Ans. A
- Q. 7 Which one of the following accessories is used with MFS template for making Groove
(A) Guide Rail (B) Coping Ring
(C) Side Stops (D) None of these. Ans. B
- Q. 8 Which one of the following accessories is used for tear free cut



BHARTIYA SKILL DEVELOPMENT UNIVERSITY

- (A) Splinter guard (B) Coping Ring
(C) Side Stops (D) None of these. Ans. A
- Q. 9 Which one of the following accessories is used in LR 32 System
- (A) Centering mandrel (B) Longitudinal Stop
(C) Side Stops (D) All of these. Ans. D
- Q. 10 Which one of the following is the maximum depth taken in Domino
- (A) 28 (B) 12
(C) 20 (D) None of these. Ans. A

Section B

04X04 = 16 Marks

Q. 11 Write short note on Zeta P2 machine?

Ans. Function of Zeta P2 are as follows:

1. Automatic Vertical movement create the Profile groove which enables to make the stronger joint.
2. It enables the fast locking system.
3. Easy assembling and disassembling.

Q. 12 What is lamello Classic X? Write down the accessories name of Lamello Classic X.

Ans. **Lamello Classic X**

It is a slot or Groove making machine for Joining one or more wooden pieces or panels together by inserting the require size biscuit in the created slot.

Accessories

1. Square Stop
2. Spacer

Q. 13 Explain the Table router with diagram?

Ans. **Push Cutting** Feeding the router in opposite direction of router bit direction is known as push cutting.

It prevents the Kick back while working exteriorly.

Climb Cutting Feeding the Router in the same direction as the direction of rotation of router bit is known as climb cutting

It is best suited while working interiorly.

Q. 14 Draw the diagram of router bit with its parts name.

Ans.



BHARTIYA SKILL DEVELOPMENT UNIVERSITY

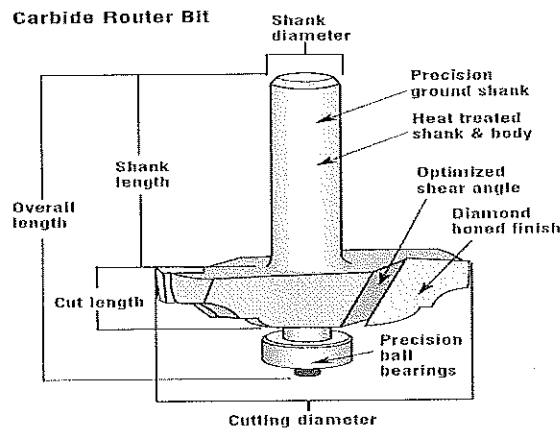

Section C

04X06 = 24 Marks

Q. 15 What are the criteria for selection of router bit and what are the material used for router bit ?

Ans. Router bit selection is based upon several factors such as

1. Cutter shape and size
2. Shank diameter
3. Cutter diameter
4. Cutter length
5. Material of router bit etc.

Material for router bit

1. Tungsten Carbide (HW)

It is best suited for hardwood such as oak, beech etc and man made material such as panels due its less wear and tear tendency.

2. High speed steel (HSS)

It is best suited for soft wood such as pine and spruce and having less life as compare to HW tool.

Q. 16 What is LR 32 system? Write down the working procedure of it.

Ans. **LR 32 System**

The festool Hole Guide System can be used in basically two modes, free-form and as a 32 mm system hole guide. In free form operations, most common use would be to create a series of shelf pin holes in cabinets. The name of the 32 mm system originates from the centre to centre spacing of the holes in the drill pattern. These holes controls the locations of door hinges, drawer glides, other hardware and the locations of the parts that make up the cabinet itself.

Accessories



BHARTIYA SKILL DEVELOPMENT UNIVERSITY

1. Guide plate
2. Centering mandrel
3. Indexing rail
4. Side stops
5. End stops

Q. 17 Explain the pendulum adjustment mechanism of Jig saw.

Ans. **Pendulum adjustment**

There are three levels for adjusting the pendulum

1. In gear one the number of stroke is less it is best suited for fine cut and for cutting hard material.
2. In gear two no of stroke is greater it cut fast but we have to compromise in surface finish.
3. In gear three no. of stroke is quite more blade cut more aggressively with poor surface finish.

Q. 18 Write Down the steps to increase the life of a router bit

Ans. Router bit selection is based upon several factors such as

1. Cutter shape and size
2. Shank diameter
3. Cutter diameter
4. Cutter length
5. Material of router bit etc.

Material for router bit

1. Tungsten Carbide (HW)

It is best suited for hardwood such as oak, beech etc and man made material such as panels due its less wear and tear tendency.

2. High speed steel (HSS)

It is best suited for soft wood such as pine and spruce and having less life.

1. Overloading
2. Lubrication
3. No of rotation
4. Router bit selection
5. Bit material



BHARTIYA SKILL DEVELOPMENT UNIVERSITY

Answer Key

School of Woodworking Skills

Session: 2021-22 (Summer Semester)

Set B

B. Voc. Program, 3rd Semester,

End Sem. Examination

Code: SCS1301

Time: 2 Hour

Course Name: Advance Power Tools

Max. Marks: 50

Instruction:

- Answer all questions from section A, each question carries one mark.
- Answer all question from section B, each question carries Four marks.
- Answer all question from section C, each question carries Six marks.

Section A

10X01 = 10 Marks

- Q. 1 Which one of the following accessories is used for Round Cut outs
- | | | |
|-----------------------|-----------------------|--------|
| (A) Centering mandrel | (B) Longitudinal Stop | |
| (C) Trammel unit | (D) All of these. | Ans. C |
- Q. 2 Which one of the following is the diameter of saw blade
- | | | |
|---------|--------------------|--------|
| (A) 160 | (B) 120 | |
| (C) 150 | (D) None of these. | Ans. A |
- Q. 3 Which of the following diameter of cutter used for 8x50 domino?
- | | | |
|-----------|----------|--------|
| (A) 10 mm | (B) 4 mm | |
| (C) 8mm | (D) 5 mm | Ans. C |
- Q. 4 Which one of the following Symbol is used for assembly
- | | | |
|--------------|-------------------|--------|
| (A) Triangle | (B) Wave Line | |
| (C) Cross | (D) All of these. | Ans. A |
- Q. 5 Which of the following depth has to take while using 4mm cutter in domino?
- | | | |
|-----------|-----------|--------|
| (A) 10 mm | (B) 40 mm | |
| (C) 28mm | (D) 20 mm | Ans. D |
- Q. 6 Which of the following is the distance between saw and riving Knife in circular Saw?
- | | | |
|-----------|--------------|--------|
| (A) 10 mm | (B) (0-5) mm | |
| (C) 8 mm | (D) 6 mm | Ans. B |
- Q. 7 Which of the following depth is set in Zeta P2 machine while making climax P14?
- | | | |
|----------|-----------|--------|
| (A) 0 mm | (B) 10 mm | |
| (C) 14mm | (D) Max | Ans. D |
- Q. 8 Which one of the following accessories is used for tear free cut



BHARTIYA SKILL DEVELOPMENT UNIVERSITY

- (A) Splinter guard (B) Coping Ring
(C) Side Stops (D) None of these. Ans. A
- Q. 9 Which one of the following accessories is used in LR 32 System
- (A) Centering mandrel (B) Longitudinal Stop
(C) Side Stops (D) All of these. Ans. D
- Q. 10 Which one of the following is the maximum depth taken in Domino
- (A) 28 (B) 12
(C) 20 (D) None of these. Ans. A

Section B

04X04 = 16 Marks

- Q. 11 What is p system? Write the function of profile groove making machine
- Ans. Function of Zeta P2 are as follows:
1. Automatic Vertical movement create the Profile groove which enables to make the stronger joint.
 2. It enables the fast locking system.
 3. Easy assembling and disassembling.
- Q. 12 Define the following with respect to lamello machine
- a) Square Stop
b) Spacer.
- Ans. **Lamello Classic X**
It is a slot or Groove making machine for Joining one or more wooden pieces or panels together by inserting the require size biscuit in the created slot.
- Accessories**
1. Square Stop
 2. Spacer
- Q. 13 Explain the router principle with diagram?
- Ans. **Push Cutting** Feeding the router in opposite direction of router bit direction is known as push cutting.
It prevents the Kick back while working exteriorly.
- Climb Cutting** Feeding the Router in the same direction as the direction of rotation of router bit is known as climb cutting
It is best suited while working interiorly.



BHARTIYA SKILL DEVELOPMENT UNIVERSITY

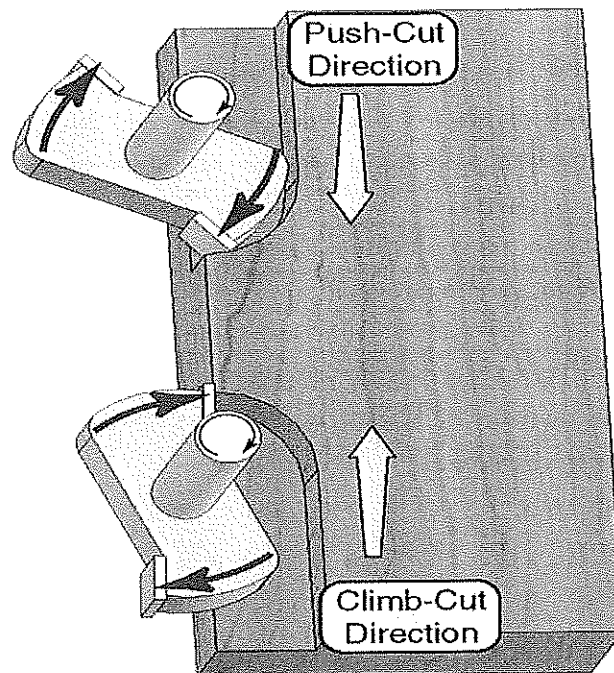

Q. 14 Write down the slot adjustment mechanism in domino machine

Ans. Depending on the requirements, the fixing hole or one of the elongated holes must be adjusted. The width of the slots can be changed by simply switching while the dowel router is running. Only one fixing hole is needed to get a perfect fit without alignment.

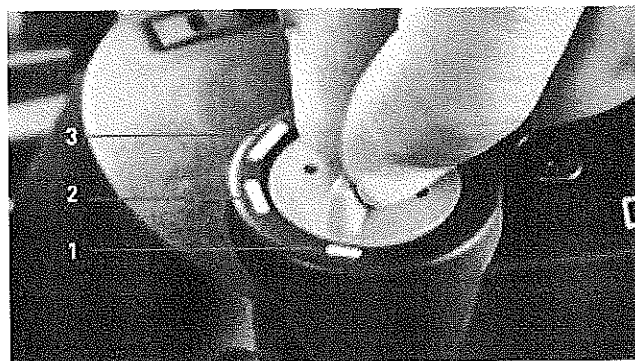

Section C

04X06 = 24 Marks

Q. 15 What is LR 32 system? Write down the accessories name of it.



BHARTIYA SKILL DEVELOPMENT UNIVERSITY

Ans. **LR 32 System**

The festool Hole Guide System can be used in basically two modes, free-form and as a 32 mm system hole guide. In free form-form operations, most common use would be to create a series of shelf pin holes in cabinets. The name of the 32 mm system originates from the centre to centre spacing of the holes in the drill pattern. These holes controls the locations of door hinges, drawer glides, other hardware and the locations of the parts that make up the cabinet itself.

Accessories

1. Guide plate
2. Centering mandrel
3. Indexing rail
4. Side stops
5. End stops

Q. 16 Explain the pendulum adjustment mechanism of Jig saw.

Ans. **Pendulum adjustment**

There are three levels for adjusting the pendulum

1. In gear one the number of stroke is less it is best suited for fine cut and for cutting hard material.
2. In gear two no of stroke is greater it cut fast but we have to compromise in surface finish.
3. In gear three no. of stroke is quite more blade cut more aggressively with poor surface finish.

Q. 17 Explain the principle of Domino machine. Define its various accessories.

Ans. **Principle**

It states that the simultaneous rotation and pendulum movement of the cutter allows smooth working and creates holes without scorch marks

Accessories

1. Cross Stop
2. Trim Stop
3. Hand Rail Fence
4. Additional fence

Q. 18 Explain the procedure to change the blade of circular saw.



BHARTIYA SKILL DEVELOPMENT UNIVERSITY

Ans. Steps to change the blade of circular saw are as follows:

1. Take out the Allen key which is placed at the top of the circular saw.
2. Tilt up the fast fix from its position and take the saw blade below from its zero position.
3. Rotate the nut and loosen it
4. Carefully take out the blade from its position.
5. Put the new saw blade according to the work piece.
6. Tight it with the help of Allen key.

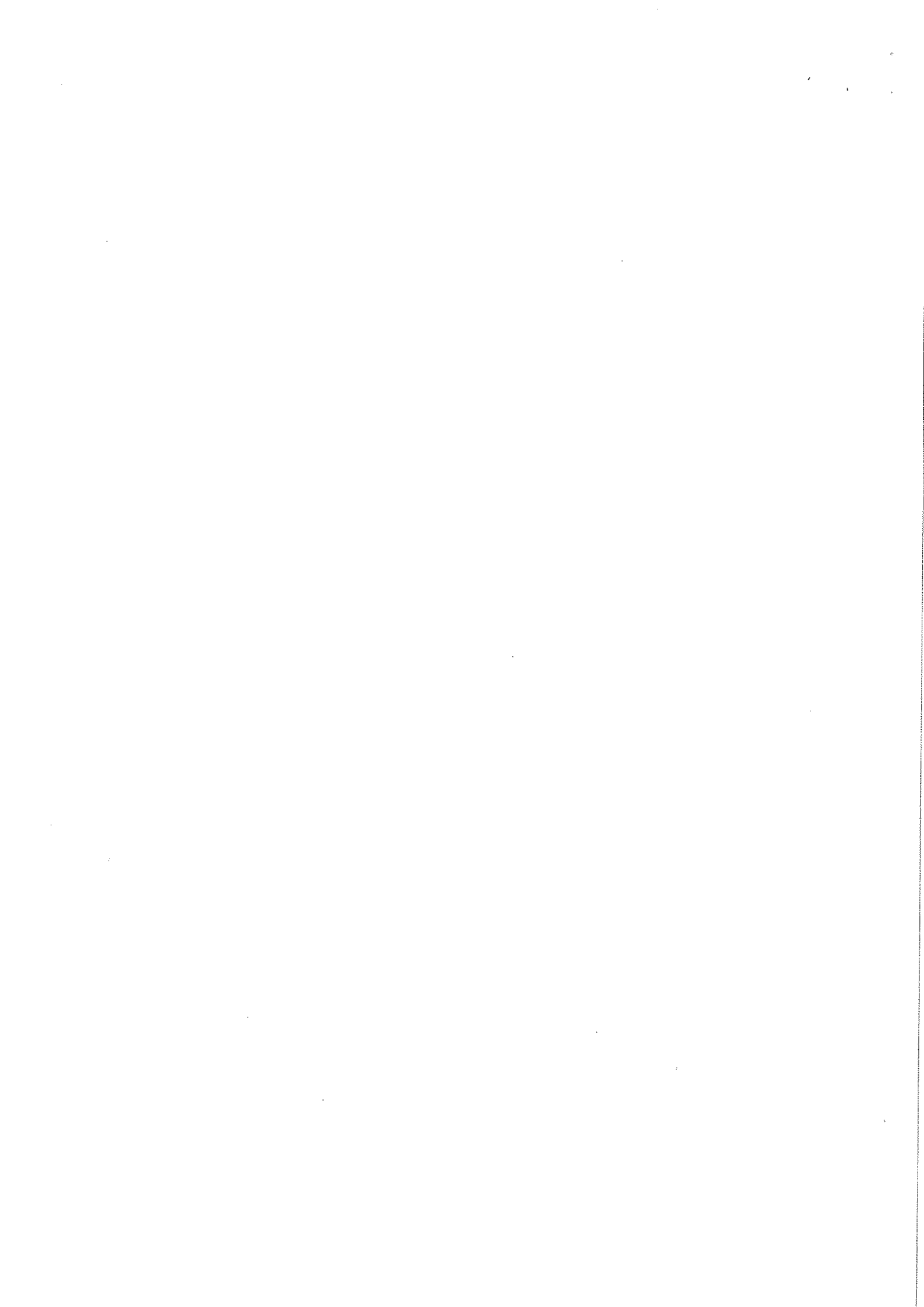



BHARTIYA SKILL DEVELOPMENT UNIVERSITY

Registration no.....

School of Woodworking Skills

Session: 2021-22 (Summer Semester)

B. Voc. Program, 3rd Semester,

Set - B

End Sem. Examination

Code: SCS1301

Time: 2 Hour

Course Name: Advance Power Tools

Max. Marks: 50

Instruction:

- Answer all questions from section A, each question carries one mark.
- Answer all question from section B, each question carries Four marks.
- Answer all question from section C, each question carries Six marks.

Section A

10X01 = 10 Marks

- Q. 1 Which one of the following accessories is used for Round Cut outs
- (A) Centering mandrel (B) Longitudinal Stop
(C) Trammel unit (D) All of these.
- Q. 2 Which one of the following is the diameter of saw blade
- (A) 160 (B) 120
(C) 150 (D) None of these.
- Q. 3 Which of the following diameter of cutter used for 8x50 domino?
- (A) 10 mm (B) 4 mm
(C) 8mm (D) 5 mm
- Q. 4 Which one of the following Symbol is used for assembly
- (A) Triangle (B) Wave Line
(C) Cross (D) All of these.
- Q. 5 Which of the following depth has to take while using 4mm cutter in domino?
- (A) 10 mm (B) 40 mm
(C) 28mm (D) 20 mm
- Q. 6 Which of the following is the distance between saw and riving Knife in circular Saw?
- (A) 10 mm (B) (0-5) mm
(C) 8 mm (D) 6 mm
- Q. 7 Which of the following depth is set in Zeta P2 machine while making climax P14?
- (A) 0 mm (B) 10 mm
(C) 14mm (D) Max
- Q. 8 Which one of the following accessories is used for tear free cut



BHARTIYA SKILL DEVELOPMENT UNIVERSITY

- (A) Splinter guard
(B) Coping Ring
(C) Side Stops
(D) None of these.
- Q. 9 Which one of the following accessories is used in LR 32 System
- (A) Centering mandrel
(B) Longitudinal Stop
(C) Side Stops
(D) All of these.
- Q. 10 Which one of the following is the maximum depth taken in Domino
- (A) 28
(B) 12
(C) 20
(D) None of these.

Section B

04X04 = 16 Marks

- Q. 11 What is p system? Write the function of profile groove making machine
- Q. 12 Define the following with respect to lamello machine
- Q. 13 Explain the router principle with diagram?
- Q. 14 Write down the slot adjustment mechanism in domino machine

Section C

04X06 = 24 Marks

- Q. 15 What is LR 32 system? Write down the accessories name of it.
- Q. 16 Explain the pendulum adjustment mechanism of Jig saw.
- Q. 17 Explain the principle of Domino machine. Define its various accessories.
- Q. 18 Explain the procedure to change the blade of circular saw.



BHARTIYA SKILL DEVELOPMENT UNIVERSITY

Registration No.:

Set – A

School of Woodworking Skills
Session: 2021-22 (Summer Semester)
B. Voc. Program, 3rd Semester,
End-Sem. Examination

Course Code: SCS1302

Time: 2 Hours

Course Name: Advance Stationary Machines

Max. Marks: 50

Instruction:

- All questions from section A, each question carries one marks.
- All questions from section B, each question carries four marks.
- All questions from section C, each question carries six marks.

Section – A

10X01 = 10 Marks

- Q.1 Which one of the following is the correct number of spindles in multiboring?
(a) 11 (b) 21
(c) 32 (d) All of them
- Q.2 Which one of the following saw blade is used for both solid wood & panel?
(a) Solid crosscut (b) Solid wood along the grains
(c) Universal (d) None of these
- Q.3 What is the maximum width of work piece to be machined in Thickness planner?
(a) 620 (b) 630
(c) 530 (d) None of these
- Q.4 Which color coated tool bit rotates in clockwise direction?
(a) Red (b) black
(c) both a & b (d) None of these
- Q.5 Which one of the following is the part of panel saw?
(a) Crosscut fence (b) Angle cut fence
(c) Main head (d) Both A & b
- Q.6 Multiboring machine drill head is rotate in 45 degree is true and false?
(a) False (b) True
- Q.7 Which one of the following machines can make two face 90 degree?
(a) Surface planner (b) Panel saw
(c) Band saw (d) None of these
- Q.8 Which one of the following tool can use to check 90 degrees angle on Surface planner?
(a) Try square (b) Folding ruler
(c) Angle protector (d) None of these
- Q.9 Which one of the following is the distance between riving knife and main saw in panel saw machine?
(a) 8-10 (b) 1-2



BHARTIYA SKILL DEVELOPMENT UNIVERSITY

(c) 5-8

(d) 3-5

Q.10 Which one of the following protection hood we used for the miter cut?

(a) Narrow protective hood

(b) Small protective hood

(c) Wide protective hood

(d) None of these

Section – B

04X04 = 16 Marks

Q.11 Explain the process of setting horizontal position of multiboring?

Q.12 What is the difference between a Hot press and cold press machine and use of this machine?

Q.13 What are the general safety rules that you should follow in the workshop?

Q.14 Write down the stapes to make a circle on panel saw machine?

Section – C

04X06 = 24 Marks

Q.15 Define the multiboring and mortise machine and write down its four parts name?

Q.16 Define the uses of band saw machine and write down blade changing process?

Q.17 Explain the spindle molder machine and write down the process of rebate profile?

Q.18 Define the uses of panel saw machine and explain the process of blade changing?



BHARTIYA SKILL DEVELOPMENT UNIVERSITY

Answer key

Set – A

School of Woodworking Skills
Session: 2021-22 (Summer Semester)
B. Voc. Program, 3rd Semester,
End-Sem. Examination

Course Code: SCS1302

Time: 2 Hours

Course Name: Advance Stationary Machines

Max. Marks: 50

Instruction:

- All questions from section A, each question carries one marks.
- All questions from section B, each question carries four marks.
- All questions from section C, each question carries six marks.

Section – A

10X01 = 10 Marks

- Q.1 Which one of the following is the correct number of spindles in multiboring?
(a) 11 (b) 21
(c) 32 (d) All of them (b)
- Q.2 Which one of the following saw blade is used for both solid wood & panel cutting?
(a) Solid crosscut (b) Solid wood along the grains
(c) Universal (d) None of these (c)
- Q.3 What is the maximum width of work piece to be machined in Thickness planner?
(a) 620 (b) 640
(c) 530 (d) None of these (d)
- Q.4 Which color coated tool bit rotates in clockwise direction?
(a) Red (b) black
(c) both a & b (d) None of these (a)
- Q.5 Which one of the following is the part of panel saw?
(a) Crosscut fence (b) Angle cut fence
(c) Main head (d) Both A & b (d)
- Q.6 Multiboring machine drill head is rotate in 45 degree is true and false?
(a) False (b) True (b)
- Q.7 Which one of the following machines can make two face 90 degree?
(a) Surface planner (b) Panel saw
(c) Band saw (d) None of these (a)
- Q.8 Which one of the following tool can use to check 90 degrees angle on Surface planner?
(a) Try square (b) Folding ruler
(c) Angle protector (d) None of these (a)



BHARTIYA SKILL DEVELOPMENT UNIVERSITY

Q.9 Which one of the following is the distance between riving knife and main saw in panel saw machine?

- (a) 8-10 (b) 1-2
(c) 5-8 (d) 3-5 (c)

Q.10 Which one of the following protection hood we used for the miter cut?

- (a) Narrow protective hood (b) Small protective hood
(c) Wide protective hood (d) None of these (c)

Section – B

04X04 = 16 Marks

Q.11 Explain the process of setting horizontal position of multiboring?

Ans.

- First of all, check for object or people in the overturning area.
- Pull the presser-holder bar back, loosening the handles.
- Pull the front stops back, loosening the handles.
- Loosen the lever.
- Keep the selector running until it reached the position and will the other hand keep pressing the release button until the position is reached.
- When the position is reached, tighten the lever again.

Q.12 What is the difference between a Hot press and cold press machine and use of this machine?

Ans. Both cold presses and hot presses are used for flattening, bonding, veneering and pressing of sheets. As the name implies, the cold press is only pressed at room temperature, and the hot press can heat the sheet, the temperature can be up to 300 degrees, and the flatness of the hot press is higher.

- It is used to press laminate with mdf.
- It is used to press laminate with particleboard.
- It is used to press veneer with ply board.
- It is used to press veneer together.
- It is used for doors.
- It is used for pressing solid wood.

Q.13 What are the general safety rules that you should follow in the workshop?

Ans. General information about safety rules -

Before attempting any work or using any power tool or machines there are general safety rules which everyone should follow in order to keep himself and others safe in workshop.

- Always listen carefully to the trainer and follow instructions.
- Do not run in the workshop, you could 'bump' into another and cause an accident.
- Know where the emergency stop buttons are positioned in the machines. If you see an accident, happening you can use the emergency stop button to stop the machine.



BHARTIYA SKILL DEVELOPMENT UNIVERSITY

- Always wear safety shoes in the workshop.
- When learning how to use a machine, listen very carefully to all the instructions given by the trainer. Ask questions, especially if you do not fully understand.
- Do not use a machine if you have not been shown how to operate it safely by the trainer.
- Always carry ear plug to the training center.
- Always use ear plug when working on a machine.
- Keep hands away from moving/rotating machinery.
- Use hand tools carefully, keeping both hands behind the cutting edge.
- Report any damage to machines/equipment as this could cause an accident.

Q.14 Write down the stapes to make a circle on panel saw machine?

- Ans. First of all make a template with a square solid wood stripe and a ply board 300*300 to fix it on panel saw table groove. Then start the machine and make a straight cut.
- Then draw a line across the panel and half of the board. And make a drill in center of panel board. After that take a MDF board according to your circle radius and make a hole in center. and put the MDF on template with matching the center hole.
- Then start the machine or cut first four big corners with clockwise rotation. Then do the same repetition for cut the new corner one by one. After that you have a multi corner then you have to fix the template in one position and rotate the work piece and take a complete round circle.

Section – C

04X06=24Marks

Q.15 Define the multiboring and mortiser machine and write down its four parts name?

Ans. Multiboring machine is generally use for drilling on the panels and grooves for drawers. Its works on laminated and non-laminated board, particle board, pvc board, melamine products, MDF board, HDF board, ply board, block board, etc.

- On/off button
- Pneumatic pedal
- Head speed adjuster
- Overturning leave button

Mortiser machine is generally use for cut mortises, or slots, in wood for mortise and tenon joints. A mortising machine is a specialized woodworking tool used for cutting square or rectangular mortises, or recesses, into wood.

- Width adjuster lever
- Depth adjuster lever
- Height adjuster gauge
- Work piece holder



BHARTIYA SKILL DEVELOPMENT UNIVERSITY

Q.16 Define the uses of band saw machine and write down blade changing process?

Ans. The Band saw is one of the powerful cutting saws. With the longer & sharper blade, it helps to cut in metals, woods, or lumber. It features uniform cutting action, distributed tooth load, irregular or curved cutting shapes.

- Before making any adjustments to your band saw, always ensure that you disconnect it from the power source.
- open the machine, loosen the band saw blade guides, and release the tension on the old blade. Most machines have a specialized lever for this very purpose.
- Remove the old blade and tie it up so that it can't cause harm.
- Hold the blade in line with the guide bearings on the saw and tighten the tension so that it gets tight enough that you don't need to hold it in place.
- Once you've achieved this tightness, you can then tighten the blade completely.
- Reverse the previous steps and close your machine, again adjusting your blade guides to their required setting.
- Before beginning any of your work, be sure to test that your blade is working correctly with a trial run on some spare material.

Q.17 Explain the spindle moulder machine and write down the process of rebate profile?

Ans. Spindle moulder are heavy duty machines that are used for the trimming and shaping of wood. Spindle Moulder make shapes, rebates and grooves on the edge of wood, composites or plastics. The machines have either fixed spindles or tilting shafts - tilting spindles give the operator more possibilities for profiling and machining.

- switch on the power supply of machine.
- Turn on safety button.
- Change the tool if required.
- Change the spindle rpm according to the tool.
- Adjust the height according to operation.
- Select the piece on which we are going to make the rebate.
- Adjust all the safety guard according to operation.
- turn off the safety button
- Switch on the machine.
- Start the operation and check the width and depth of rebate.
- Complete the rebate and check the dimension.

Note: -

- Wear all the safety equipment during the whole process.
- Check all locks before turning on the machine.
- Use all the safety gears.

Check that nobody is standing behind the machine.

Q.18 Define the uses of panel saw machine and explain the process of blade changing?



BHARTIYA SKILL DEVELOPMENT UNIVERSITY

Ans. Panel saws are used by woodworking industry to easily cut panels, profiles, solid-wood, plywood, MDF, laminates, plastic sheets and melamine sheets into sizes or cabinet components. They are also used by sign shops to cut sheets of aluminum, plastic and wood for their sign blanks.

- To change the blade of panel saw first of all push bed of panel saw in forward direction by pressing lever below the bed.
- Open saw carriage and lock spindle by using spindle locking key.
- With the help of spanner unlock nut in cutting direction.
- Change blade and fasten nut.
- Closed saw carriage and pull bed of panel saw back.

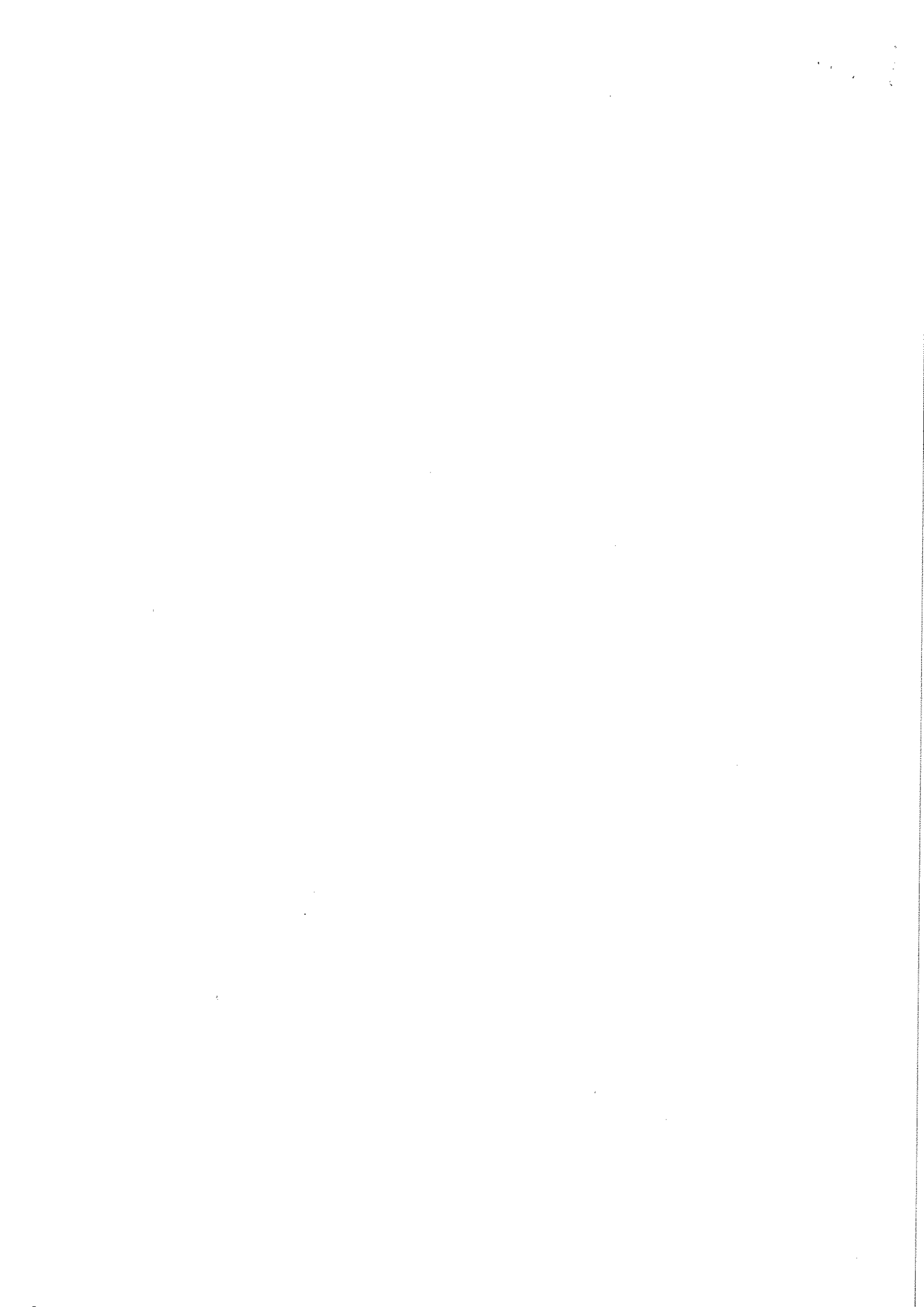



BHARTIYA SKILL DEVELOPMENT UNIVERSITY

Registration No.:

Set – B

School of Woodworking Skills
Session: 2021-22 (Summer Semester)
B. Voc. Program, 3rd Semester,
End-Sem. Examination

Course Code: SCS1302

Time: 2 Hours

Course Name: Advance Stationary Machines

Max. Marks: 50

Instruction:

- All questions from section A, each question carries one marks.
- All questions from section B, each question carries four marks.
- All questions from section C, each question carries six marks.

Section – A

10X01 = 10 Marks

- Q.1 Which one of the following is controlled on the outfeed table of the surface planner?
(a) Height (b) Depth
(c) Angle (d) All of them
- Q.2 Which one of the following is the function of scoring saw blade?
(a) Avoid chip out (b) used to make curves
(c) Used to make a groove (d) None of these
- Q.3 Which one the following is the definition of recycling?
(a) Art of making resource into waste (b) Manufacturing new products
(c) Art of making waste into a resource (d) None of these
- Q.4 Which one of the following is maximum one-time depth of cut of Thicknesser machine?
(a) 4mm (b) 6mm
(c) 5mm (d) 3mm
- Q.5 Which one of the following is an example of fiber board?
(a) MDF (b) LDF
(c) Solid wood (d) Both A& B
- Q.6 Which of the Following Tool is used in levelling while installation?
(a) Spirit Level (b) Level bevel
(c) Level Meter (d) Dumpy Level
- Q.7 Which one of the following protection hood we used for the miter cut?
(a) Narrow protective hood (b) Small protective hood
(c) Wide protective hood (d) None of these
- Q.8 Which one of the following tool can use to check 90 degrees angle on Surface planner?
(a) Try square (b) Folding ruler
(c) Angle protector (d) None of these

Handwritten signature



BHARTIYA SKILL DEVELOPMENT UNIVERSITY

Q.9 Which one of the following is the distance between riving knife and main saw in panel saw machine?

- (a) 8-10 (b) 1-2
(c) 5-8 (d) 3-5

Q.10 Which one of the following machines can make two face 90 degree?

- (a) Surface planner (b) Panel saw
(c) Band saw (d) None of these

Section – B

04X04 = 16 Marks

Q.11 Write down the function of the protective hood on the panel saw.

Q.12 Write down the setting of the fence on the surface planner step by step?

Q.13 Define the uses of panel saw machine and explain the process of blade changing?

Q.14 Write the process of setting horizontal position of multiboring?

Section – C

04X06 = 24 Marks

Q. 15 Explain the spindle moulder machine and write down the process of rebate profile?

Q.16 Write down the safe and efficient hand position while working on the surface planner.

Q.17 What are the general safety rules that you should follow in the workshop?

Q.18 Draw a labelled diagram of thickness planer, highlight all the electrical buttons and write down the steps to thickness a work piece to required dimension.



BHARTIYA SKILL DEVELOPMENT UNIVERSITY

Answer key

Set – B

School of Woodworking Skills
Session: 2021-22 (Summer Semester)
B. Voc. Program, 3rd Semester,
End-Sem. Examination

Course Code: SCS1302

Time: 2 Hours

Course Name: Advance Stationary Machines

Max. Marks: 50

Instruction:

- All questions from section A, each question carries one marks.
- All questions from section B, each question carries four marks.
- All questions from section C, each question carries six marks.

Section – A

10X01 = 10 Marks

- Q.1 Which one of the following is controlled on the outfeed table of the surface planner?
(a) Height (b) Depth
(c) Angle (d) All of them (c)
- Q.2 Which one of the following is the function of scoring saw blade?
(a) Avoid chip out (b) used to make curves
(c) Used to make a groove (d) None of these (a)
- Q.3 Which one the following is the definition of recycling?
(a) Art of making resource into waste (b) Manufacturing new products
(c) Art of making waste into a resource (d) None of these (c)
- Q.4 Which one of the following is maximum one-time depth of cut of Thicknesser machine?
(a) 4mm (b) 6mm
(c) 5mm (d) 3mm (c)
- Q.5 Which one of the following is an example of fiber board?
(a) MDF (b) LDF
(c) Solid wood (d) Both A& B (d)
- Q.6 Which of the Following Tool is used in levelling while installation?
(a) Spirit Level (b) Level bevel
(c) Level Meter (d) Dumpy Level (a)
- Q.7 Which one of the following protection hood we used for the miter cut?
(a) Narrow protective hood (b) Small protective hood
(c) Wide protective hood (d) None of these (c)
- Q.8 Which one of the following tool can use to check 90 degrees angle on Surface planner?
(a) Try square (b) Folding ruler
(c) Angle protector (d) None of these (a)



BHARTIYA SKILL DEVELOPMENT UNIVERSITY

Q.9 Which one of the following is the distance between riving knife and main saw in panel saw machine?

- (a) 8-10 (b) 1-2
(c) 5-8 (d) 3-5 (d)

Q.10 Which one of the following machines can make two face 90 degree?

- (a) Surface planner (b) Panel saw
(c) Band saw (d) None of these (a)

Section – B

04X04 = 16 Marks

Q.11 Write down the function of the protective hood on the panel saw.

Ans. Protective hood function –

1. Protective hood use protection against contact with the circular saw blade.
2. Preventing a work piece kickback.
3. Protection against splintering wood parts, branches and sawdust extraction of the chips.
4. Sawblade protection hood for straight cut
5. Protection hood for mitre cut

Q.12 Write down the setting of the fence on the surface planner step by step?

Ans. Right angle –

- Suitable for small parts planning right angle the angle stop is set to 90° is controlled on the outfeed table with a precise angle.

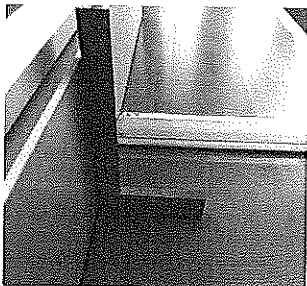

Bevels –

- Chamfer and sloop planning, the stop is adjusted with the bevel.
- This is controlled on the outfeed table.



Q.13 Define the uses of panel saw machine and explain the process of blade changing?

Ans. Panel saws are used by woodworking industry to easily cut panels, profiles, solid-wood, plywood, MDF, laminates, plastic sheets and melamine sheets into sizes or cabinet



BHARTIYA SKILL DEVELOPMENT UNIVERSITY

components. They are also used by sign shops to cut sheets of aluminum, plastic and wood for their sign blanks.

- To change the blade of panel saw first of all push bed of panel saw in forward direction by pressing lever below the bed.
- Open saw carriage and lock spindle by using spindle locking key.
- With the help of spanner unlock nut in cutting direction.
- Change blade and fasten nut.
- Closed saw carriage and pull bed of panel saw back.

Q.14 Write the process of setting horizontal position of multiboring?

Ans.

- First of all, check for object or people in the overturning area.
- Pull the presser-holder bar back, loosening the handles.
- Pull the front stops back, loosening the handles.
- Loosen the lever.
- Keep the selector running until it reached the position and will the other hand keep pressing the release button until the position is reached.
- When the position is reached, tighten the lever again.

Section – C

04X06 = 24 Marks

Q.15 Explain the spindle moulder machine and write down the process of rebate profile?

Ans. Spindle moulder are heavy duty machines that are used for the trimming and shaping of wood. Spindle Moulder make shapes, rebates and grooves on the edge of wood, composites or plastics. The machines have either fixed spindles or tilting shafts - tilting spindles give the operator more possibilities for profiling and machining.

- switch on the power supply of machine.
- Turn on safety button.
- Change the tool if required.
- Change the spindle rpm according to the tool.
- Adjust the height according to operation.
- Select the piece on which we are going to make the rebate.
- Adjust all the safety guard according to operation.
- turn off the safety button
- Switch on the machine.
- Start the operation and check the width and depth of rebate.
- Complete the rebate and check the dimension.

Note: -

- Wear all the safety equipment during the whole process.
- Check all locks before turning on the machine.
- Use all the safety gears.

Check that nobody is standing behind the machine.

Q.16 Write down the safe and efficient hand position while working on the surface planner.

Ans.

Safe and efficient work –

- Hand position
- Pressure distribution



BHARTIYA SKILL DEVELOPMENT UNIVERSITY

Hand position when planning –

- When planning the wood, the hand should be open and flat on the work piece.
- The fingers are closed.
- The concave side of the work piece placed on the feed table.



Hand position when planning –

When planning wood, the thumbs are on the top edge and the other fingers rolled and the push the work piece against the stop.



Pressure distribution –

When planning the work piece, the pressure on the work piece should be on the dressing table.

Q.17 What are the general safety rules that you should follow in the workshop?

Ans. General information about safety rules -

Before attempting any work or using any power tool or machines there are general safety rules which everyone should follow in order to keep himself and others safe in workshop.

- Always listen carefully to the trainer and follow instructions.
- Do not run in the workshop, you could 'bump' into another and cause an accident.
- Know where the emergency stop buttons are positioned in the machines. If you see an accident, happening you can use the emergency stop button to stop the machine.
- Always wear safety shoes in the workshop.
- When learning how to use a machine, listen very carefully to all the instructions given by the trainer. Ask questions, especially if you do not fully understand.
- Do not use a machine if you have not been shown how to operate it safely by the trainer.
- Always carry ear plug to the training center.
- Always use ear plug when working on a machine.



BHARTIYA SKILL DEVELOPMENT UNIVERSITY

- Keep hands away from moving/rotating machinery.
- Use hand tools carefully, keeping both hands behind the cutting edge.

Report any damage to machines/equipment as this could cause an accident.

Q.18 Draw a labelled diagram of thickness planer, highlight all the electrical buttons and write down the steps to thickness a work piece to required dimension.

Main electrical switch

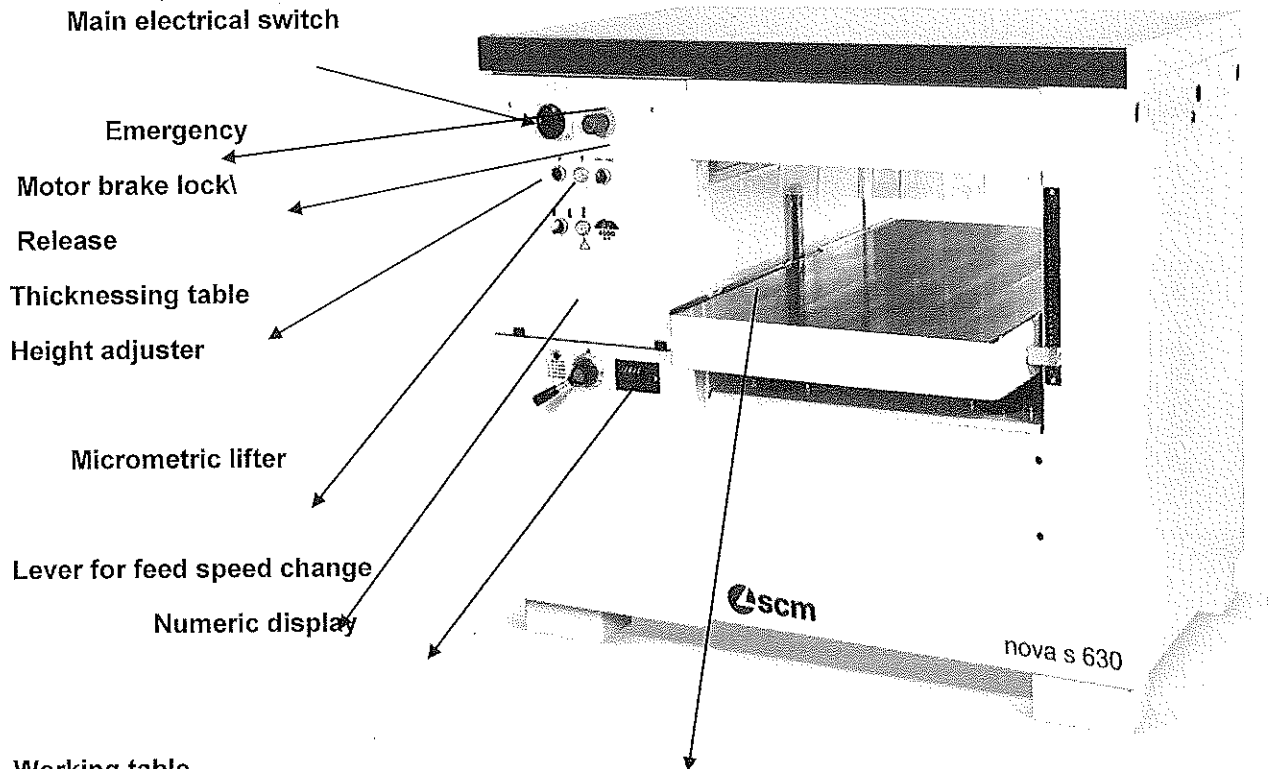

Working table

- Make sure that top cover is closed.
- Make sure that the emergency button is released; otherwise turn them in the arrow direction.
- Make sure that the dust collector is on.
- Turn main switch on.
- Turn starter to star position, after some second turn it to delta position.
- To lift or to lower the thicknessing table operate on selector, the table moves at high speed to the direction indicated by the selector.
- Reach the right position with micrometric shiftments of the thicknessing table by pressing button, which will carry shiftments at low speed only upwards.
- Place the work piece to the working table.

Machine the work piece until the required dimension is achieved.





Registration No.:

BHARTIYA SKILL DEVELOPMENT UNIVERSITY

Registration No.....

School of Woodworking Skills

Session: 2021-22 (Summer Semester) Set A

B. Voc. Program, 3rd Semester,

End Sem. Examination

Course Code: SCS1303

Course Name: Advanced Assembly and Fittings

Time: 2 Hour

Max. Marks: 50

Instruction:

- Answer all questions from section A, each question carries one mark.
- Answer all question from section B, each question carries four marks.
- Answer all question from section C, each question carries six marks.

Section – A

10X01 = 10 Marks

- Q.1 Which one of the following Concealed hinge is used for individual cabinets?
(a) half overlay hinge (b) full overlay hinge
(c) inset hinge (d) all of them
- Q. 2 Which one of the following is the Concealed hinge mounted on middle partition of the cabinet?
(a) half overlay hinge (b) full overlay hinge
(c) inset hinge (d) but hinge
- Q. 3 Which one of the following lock used for external door?
(a) Mortise Lock (b) cam lock
(c) pad lock (d) knob lock
- Q. 4 Which one of the following lock is not permanently attached to anything else?
(a) Mortise Lock (b) cam lock
(c) pad lock (d) knob lock
- Q. 5 Which one of the following runner mounted on the bottom edge of each drawer side?
(a) nylon runner (b) steel ball bearing runner
(c) soft close runner (d) none of them
- Q. 6 Which one of the following is used for 10 mm MDF Sheet
(A) P10 (B) P14
(C) P12 (D) P14
- Q. 7 Which one of the following is a function of the runner?



BHARTIYA SKILL DEVELOPMENT UNIVERSITY

- (A) used to facilitate fluid motion during opening and closing.
(B) it is produce friction
(C) it provide hard opening
(D) none of them
- Q. 8 Which one of the following value is standard distance between two holes in adjustable shelf of a cabinet?
- (A) 30 mm (B) 32 mm
(C) 37mm (D) 33 mm
- Q. 9 Which one of the following sign is helpful in assembly?
- (A) snake line (B) circle mark
(C) Cross sign (D) None of these
- Q. 10 Which one of the following fitting is permanent fitting?
- (A) Clamex P – 14 (B) Clamex P - 15
(C) Lamello Biscuits (D) Knock down fitting

Section – B

04X04 = 16 Marks

- Q. 11 What is furniture fittings? Write down the significance of runner and hinge.
- Q. 12 Explain the any two types of hinges with figure.
- Q. 13 Write short note on following
- a) Mortise
b) Cam
- Q. 14 Describe the following with diagram
- a) Butt Joint
b) Tenon Mortise

Section – C

04X06 = 24 Marks

- Q. 15 Explain the procedure to install but hinges.
- Q. 16 What is runner? Write down its function.
- Q. 17 What is concealed hinges? Explain the half overlay hinge with figure.
- Q. 18 Explain the RTA and fasteners with diagram



BHARTIYA SKILL DEVELOPMENT UNIVERSITY

School of Woodworking Skills

Session: 2021-22 (Summer Semester) Set A- Answer

B. Voc. Program, 3rd Semester,

End Sem. Examination

Course Code: SCS1303

Course Name: Advanced Assembly and Fittings

Time: 2 Hour

Max. Marks: 50

Instruction:

- Answer all questions from section A, each question carries one mark.
- Answer all question from section B, each question carries four marks.
- Answer all question from section C, each question carries six marks.

Section – A

10X01 = 10 Marks

- Q.1 Which one of the following Concealed hinge is used for individual cabinets?(b)
- (a) half overlay hinge (b) full overlay hinge
(c) inset hinge (d) all of them
- Q. 2 Which one of the following is the Concealed hinge mounted on middle partition of the cabinet? (a)
- (a) half overlay hinge (b) full overlay hinge
(c) inset hinge (d) but hinge
- Q. 3 Which one of the following lock used for external door? (c)
- (a) Mortise Lock (b) cam lock
(c) pad lock (d) knob lock
- Q. 4 Which one of the following lock is not permanently attached to anything else?(c)
- (a) Mortise Lock (b) cam lock
(c) pad lock (d) knob lock
- Q. 5 Which one of the following runner mounted on the bottom edge of each drawer side? (c)
- (a) nylon runner (b) steel ball bearing runner
(c) soft close runner (d) none of them
- Q. 6 Which one of the following is used for 10 mm MDF Sheet. (a)
- (A) P10 (B) P14
(C) P12 (D) P14

**BHARTIYA SKILL DEVELOPMENT UNIVERSITY**

- Q. 7 Which one of the following is a function of the runner? (a)
- (A) used to facilitate fluid motion during opening and closing.
 - (B) it is produce friction
 - (C) it provide hard opening
 - (D) none of them
- Q. 8 Which one of the following value is standard distance between two holes in adjustable shelf of a cabinet? (b)
- (A) 30 mm
 - (B) 32 mm
 - (C) 37mm
 - (D) 33 mm
- Q. 9 Which one of the following sign is helpful in assembly? (d)
- (A) snake line
 - (B) circle mark
 - (C) Cross sign
 - (D) None of these
- Q. 10 Which one of the following fitting is permanent fitting? (c)
- (A) Clamex P – 14
 - (B) Clamex P - 15
 - (C) Lamello Biscuits
 - (D) Knock down fitting

Section – B**04X04 = 16 Marks**

Q. 11 What is furniture fittings? Write down the significance of runner and hinge.

Ans.

Furniture hardware are those products that are used to support the furniture look, design and durability. Furniture hardware products include furniture frames, furniture legs, furniture arms, windows, doors, and cabinets etc. Common examples include hinges, handles.

significance of hinge- A hinge is a mechanical bearing that connects two solid objects, typically allowing only a limited angle of rotation between them. Two objects connected by an ideal hinge rotate relative to each other about a fixed axis of rotation: all other translations or rotations being prevented, and thus a hinge has one degree of freedom.

significance of runner - Drawer runners are small devices that are used to facilitate fluid motion during opening and closing.

Q. 12 Explain the any two types of hinges with figure.

Ans.

Slip Hinge -

Slip_hinges are great for removable door or lid applications. Typical applications are cabinets, control boxes and computer housings where easy, full access to the interior is required.

BHARTIYA SKILL DEVELOPMENT UNIVERSITY

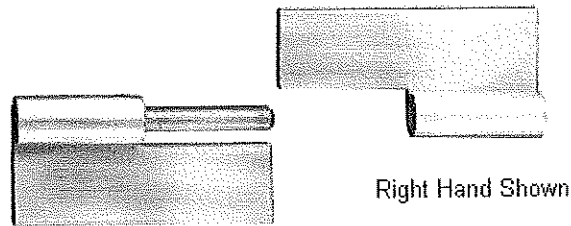

Spring Hinge -

Spring hinges are ideal for applications that require holding doors and lids in an open or closed position.

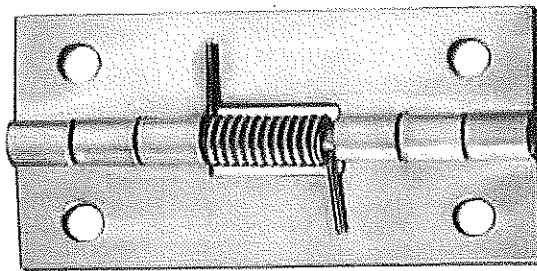

Q. 13 Write short note on following

- a) Mortise
- b) Cam

Ans.

(a) Mortise Locks -

Mortise locks are powerful locks used on external doors. However, they are available in both light and heavy duty models. They are comprised of an internal system which makes them more of locksets than just locks. These locksets can house either knobs or levers and are often comprised of a cylindrical body. They are threaded and utilize mortise components added within the door.

(b) Cam Locks -

Cam locks are used in a variety of applications but are most frequently found in filing cabinets, mailboxes, and lower security OEM applications. They come in several different lengths and can use a variety of tail pieces or "cams" to interface with another locking mechanism. There is a very large variety of cam options.

BHARTIYA SKILL DEVELOPMENT UNIVERSITY

Q. 14 Describe the following with diagram

- a) Butt Joint
- b) Tenon Mortise

Ans.

a) Butt Joint –

- A butt joint is a technique in which two pieces of material are joined by simply placing their ends together without any special shaping.
- The butt joint is the simplest joint to cutting the wood to the appropriate length and butting them together by glue with holding together.
- The parts must be precisely equal in order to achieve good joint. Generally used to make board wider.
- It can be stronger if we are using some fasteners screws, nails, dowels etc.
- Advantage – Fast and easy joining
- Disadvantage – Limited strength
 - The work parts slip easily when pressing parts.

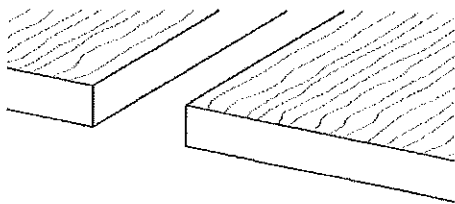

b) Tenon and mortise joints –

- A mortise and tenon joint is a type of joint that connects two pieces of wood at an angle of 90
- Mortise and tenon are two components: the mortise hole and the tenon tongue.
- The tenon is cut to fit the mortise hole exactly and usually has shoulders that seat when the joint fully enters the mortise hole. The joint may be glued, pinned, or wedged to lock it in place.
- Advantage – Very good strength for heavy doors and gates
 - It is both simple and strong
- Disadvantage – Complex production while mortise hole

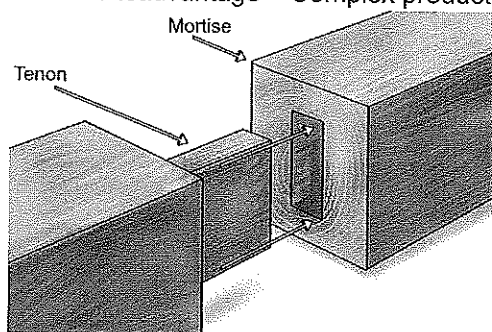

**BHARTIYA SKILL DEVELOPMENT UNIVERSITY****Section – C****04X06 = 24 Marks**

Q. 15 Explain the procedure to install butt hinges.

ans.

Process to Instal butt hinge -.

1. First we have to select the mating parts by hinges and accordingly no of hinges we have to decide.
2. Mark the dimension on work piece according to the hinge plate thickness, width and length on door as well as frame.
3. Measure the knuckle & hinge plate thickness and make routing according to that for material removing in both parts.
4. Check the slot depth and insert hinge in both groove and mark screw position and drilling as screw dimensions.
5. After that we have to assemble mating parts with hinges with screws. Check the required functioning requirement.

Q. 16 What is runner? Write down its function.

Ans.

Drawer runners are small devices that are used to facilitate fluid motion during opening and closing.

- The simplest drawer runners had a small set of wheels that are attached to the external sides of the drawer.
- Within the base cabinet frame where the drawer is set, a small guiding track will be installed to accept the wheels of the drawer.
- Drawer slides use guides, bearings, or rollers to support drawers and facilitate their motion. They provide smooth action and high lateral stability.
- There are many different types of drawer slides. Examples include:
 - heavy duty drawer slides

Q. 17 What is concealed hinges? Explain the half overlay hinge with figure.

Ans.

Concealed hinges -

Concealed hinges are fully concealed behind the cabinet door, so they're not visible when the door is closed. They're self-closing and usually easily adjustable. They are the most common used of the cabinet door hinges. The mounting plate is fitted to the cabinet and a special bit is used to drill out the back of the door to take the cup hinge.

BHARTIYA SKILL DEVELOPMENT UNIVERSITY

Half overlay hinge –

Half overlay hinges are intended for pairs of doors in the middle of a run of cabinets, where two doors have their hinges mounted on opposite sides of a shared middle partition.

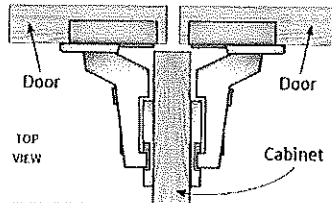

Q. 18 Explain the RTA and fasteners with diagram

Ans.

Ready To Assembly fitting (RTA) - It is ready to assemble fitting which is also known as knock down fitting, it come with the assembly of three parts,

- a. Cam - The disk fits into a recess in the first side of the cabinet. It rotates by inserting a screwdriver into the slot in its side. The shaft is screwed into the second side of the cabinet. The collar of the shaft is passed through the hole in the second slot in the disk. When the disk rotates the shaft is locked in position. This keeps both sides of the cabinet locked together.

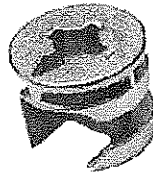

- b. Connecting Screw – Connecting screw is a cylindrical screw which have two ends and one of the end inserts in the socket and another end inserts in the cam. It is used to connect joint and to give strength to it.

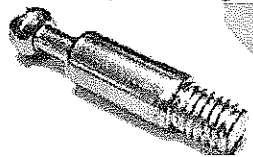

- c. Socket – Socket is assembled in second part of assembly. It is used to provide grip to the connecting screw.





Registration No.:

BHARTIYA SKILL DEVELOPMENT UNIVERSITY

Registration No.....

School of Woodworking Skills

Session: 2021-22 (Summer Semester) Set B

B. Voc. Program, 3rd Semester,

End Sem. Examination

Course Code: SCS1303

Course Name: Advance Assembly and Fittings

Time: 2 Hour

Max. Marks: 50

Instruction:

- Answer all questions from section A, each question carries one mark.
- Answer all question from section B, each question carries four marks.
- Answer all question from section C, each question carries six marks.

Section – A

10X01 = 10 Marks

- Q.1 Which one of the following Concealed hinge is used for individual cabinets?
- (a) half overlay hinge (b) full overlay hinge
(c) inset hinge (d) all of them
- Q. 2 Which one of the following is the Concealed hinge is used when door is installed in one partition of the cabinet?
- (a) half overlay hinge (b) full overlay hinge
(c)Both a & b (d) but hinge
- Q. 3 Which one of the following known as detachable connection fittings
- (a) Lamello (b) Clamax
(c) Domino (d) knob lock
- Q. 4 Which one of the following lock is not permanently attached to anything else?
- (a) Mortise Lock (b) cam lock
(c) pad lock (d) knob lock
- Q. 5 Which one of the following runner mounted on the bottom edge of each drawer side?
- (a) nylon runner (b) steel ball bearing runner
(c) soft close runner (d) none of them

[Handwritten signature]



BHARTIYA SKILL DEVELOPMENT UNIVERSITY

- Q. 6 Which one of the following is used for 10 mm MDF Sheet
(A) P10 (B) P14
(C) P12 (D) P14
- Q. 7 Which one of the following is a function of the runner?
(A) used to facilitate fluid motion during opening and closing.
(B) it is produce friction
(C) it provide hard opening
(D) none of them
- Q. 8 Standard distance between two holes in adjustable shelf of a cabinet?
(A) 30 mm (B) 32 mm
(C) 37mm (D) 33 mm
- Q. 9 Which one of the following sign is helpful in assembly?
(A) snake line (B) circle mark
(C) Cross sign (D) None of these
- Q. 10 Which one of the following fitting is permanent fitting?
(A) Clamex P – 14 (B) Clamex P - 15
(C) Lamello Biscuits (D) Knock down fitting

Section – B

04X04 = 16 Marks

- Q. 11 What is furniture fittings? Write down the significance any two hinge.
- Q. 12 Explain any two types of hinges with figure.
- Q. 13 Write short note on following
a) Climax
b) Biscuit
- Q. 14 Describe the following with diagram
a) Lap Joint
b) Tounge and

Section – C

04X06 = 24 Marks

- Q. 15 Explain the step to make a cabinet with all dimensional parameters.
- Q. 16 What is runner? Write down its application.



Registration No.:

BHARTIYA SKILL DEVELOPMENT UNIVERSITY

- Q. 17 What is concealed hinges? Explain the Full overlay hinge with figure.
- Q. 18 Explain the RTA and fasteners with diagram



**BHARTIYA SKILL DEVELOPMENT UNIVERSITY**

School of Woodworking Skills

Session: 2021-22 (Summer Semester) Set B- Answer key

B. Voc. Program, 3rd Semester,

End Sem. Examination

Course Code: SCS1303

Course Name: Advance Assembly and Fittings

Time: 2 Hour

Max. Marks: 50

Instruction:

- Answer all questions from section A, each question carries one mark.
- Answer all question from section B, each question carries four marks.
- Answer all question from section C, each question carries six marks.

Section – A**10X01 = 10 Marks**

- Q.1 Which one of the following Concealed hinge is used for individual cabinets? (b)
- (a) half overlay hinge (b) full overlay hinge
(c) inset hinge (d) all of them
- Q. 2 Which one of the following is the Concealed hinge is used when door is installed in one partition of the cabinet? (a)
- (a) half overlay hinge (b) full overlay hinge
(c)Both a & b (d) but hinge
- Q. 3 Which one of the following known as detachable connection fittings (b)
- (a) Lamello (b) Clamax
(c) Domino (d) knob lock
- Q. 4 Which one of the following lock is not permanently attached to anything else? (c)
- (a) Mortise Lock (b) cam lock
(c) pad lock (d) knob lock
- Q. 5 Which one of the following runner mounted on the bottom edge of each drawer side? (a)
- (a) nylon runner (b) steel ball bearing runner
(c) soft close runner (d) none of them
- Q. 6 Which one of the following is used for 10 mm MDF Sheet (a)
- (A) P10 (B) P14
(C) P12 (D) P14
- Q. 7 Which one of the following is a function of the runner? (a)
- (A) used to facilitate fluid motion during opening and closing.

**BHARTIYA SKILL DEVELOPMENT UNIVERSITY**

- (B) it is produce friction
(C) it provide hard opening
(D) none of them
- Q. 8 Standard distance between two holes in adjustable shelf of a cabinet? (b)
(A) 30 mm (B) 32 mm
(C) 37mm (D) 33 mm
- Q. 9 Which one of the following sign is helpful in assembly? (d)
(A) snake line (B) circle mark
(C) Cross sign (D) None of these
- Q. 10 Which one of the following fitting is permanent fitting? (c)
(A) Clamex P – 14 (B) Clamex P - 15
(C) Lamello Biscuits (D) Knock down fitting

Section – B**04X04 = 16 Marks**

Q. 11 What is furniture fittings? Write down the significance any two hinge.

Ans.

Furniture hardware are those products that are used to support the furniture look, design and durability. Furniture hardware products include furniture frames, furniture legs, furniture arms, windows, doors, and cabinets etc. Common examples include hinges, handles.

significance of hinge- A hinge is a mechanical bearing that connects two solid objects, typically allowing only a limited angle of rotation between them. Two objects connected by an ideal hinge rotate relative to each other about a fixed axis of rotation: all other translations or rotations being prevented, and thus a hinge has one degree of freedom.

Q. 12 Explain any two types of hinges with figure.

Ans.

Slip Hinge -

Slip_hinges are great for removable door or lid applications. Typical applications are cabinets, control boxes and computer housings where easy, full access to the interior is required.

BHARTIYA SKILL DEVELOPMENT UNIVERSITY

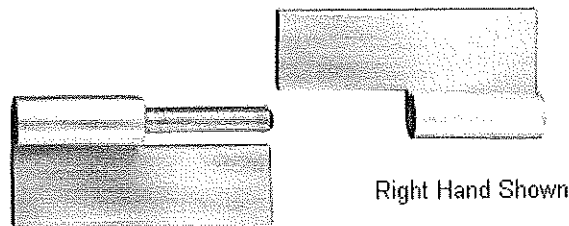

Spring Hinge -

Spring hinges are ideal for applications that require holding doors and lids in an open or closed position.

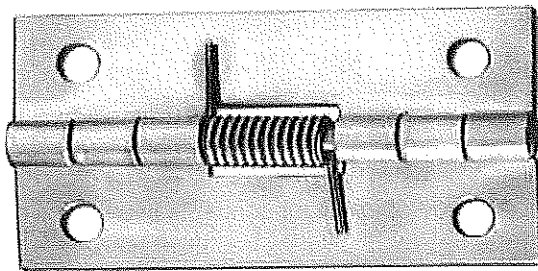

Q. 13 Write short note on following

- a) Climax
- b) Biscuit

Ans.

A) Climax - These are the detachable connecting fittings.

- Clamex P is a detachable furniture fitting on the basis of the P-System is connected with a lever.
- Clamex P is not required glue
- Practically wear-free knock down fitting
- General sizes of Biscuits are –
 - i. Clamex P 10 – 52 x 19 x 9.7 mm
 - ii. Lamello 10 – 66 x 27 x 9.7 mm

B) A biscuit joiner is a wood working tool used to join two pieces of wood together. A biscuit joiner uses a small circular saw blade to cut a crescent-shaped hole (called the mouth) in the opposite edges of two pieces of wood or wood composite panels.

Q. 14 Describe the following with diagram

BHARTIYA SKILL DEVELOPMENT UNIVERSITY

- a) Lap Joint
- b) Tounge and groove

Ans.

a) Lap Joint- A lap joint or overlap joint is a joint in which the members overlap.

- Lap joints can be used to join wood, plastic, or metal. A lap joint may be a full lap or half lap.
- In a half lap joint or halving joint, material is removed from both of the members so that the resulting joint is the thickness of the thickest member.
- Advantage – Simple production
- Disadvantage – Low strength joint

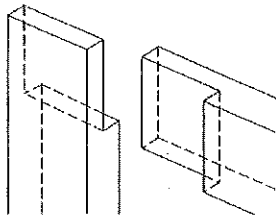

b) Tounge and groove- A mortise and tenon joint is a type of joint that connects two pieces of wood at an angle of 90

- Mortise and tenon are two components: the mortise hole and the tenon tongue.
- The tenon is cut to fit the mortise hole exactly and usually has shoulders that seat when the joint fully enters the mortise hole. The joint may be glued, pinned, or wedged to lock it in place.
- Advantage – Very good strength for heavy doors and gates
 - It is both simple and strong
- Disadvantage – Complex production while mortise hole

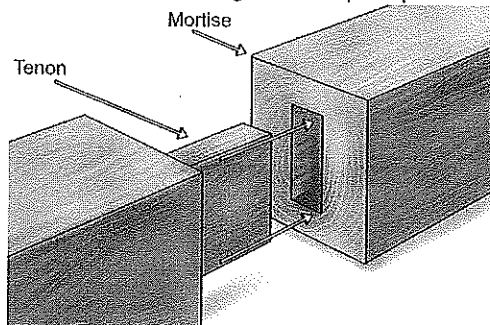

Section – C

04X06 = 24 Marks

Q. 15 Explain the step to make a cabinet with all dimensional parameters.

Ans.

1. First collect all tools that are required like screw driver, Cordless drill, screw according to the cabinet wall and measuring instruments.
2. Take the measurement of the cabinet and drawer.
3. According to the measurement of the drawer and cabinet select drawer runner. Runner length must be shorter than the length of drawer.

BHARTIYA SKILL DEVELOPMENT UNIVERSITY

4. Bearing runner are generally attached to the bottom of drawer because it gives more load capacity.
5. Marking on cabinet walls and attach the half part of runner with screw on wall.
6. Now start marking other half part of the runner, while marking maintain the distance of runner from front part.
7. Attach the other half part on bottom of drawer runner with screw.
8. After that insert runner inside with force, after complete assembly we can adjust the height of raver with the help of screws.

Q. 16 What is runner? Write down its application.

Ans.

Runners & its application –

Drawer runners are small devices that are used to facilitate fluid motion during opening and closing.

- The simplest drawer runners had a small set of wheels that are attached to the external sides of the drawer.
- Within the base cabinet frame where the drawer is set, a small guiding track will be installed to accept the wheels of the drawer.
- Drawer slides use guides, bearings, or rollers to support drawers and facilitate their motion. They provide smooth action and high lateral stability.
- There are many different types of drawer slides. Examples include:
 - heavy duty drawer slides
 - ball bearing drawer slides
 - full extension drawer slides
 - plastic drawer slides

Q. 17 What is concealed hinges? Explain the Full overlay hinge with figure.

Ans.

Concealed hinges - are fully concealed behind the cabinet door, so they're not visible when the door is closed. They're self-closing and usually easily adjustable. They are the most common used of the cabinet door hinges. The mounting plate is fitted to the cabinet and a special bit is used to drill out the back of the door to take the cup hinge. products are made of materials like plastics, metals and may be glasses.

Full overlay hinge –

This hinge is the type of Concealed hinge, overlay doors do exactly what the name implies: They cover the cabinet opening completely, overlapping the cabinet case or face frame on all sides

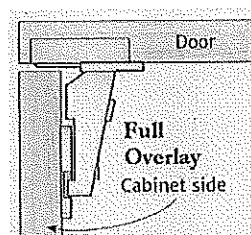

Q. 18 Explain the RTA and fasteners with diagram

BHARTIYA SKILL DEVELOPMENT UNIVERSITY

Ans.

Ready To Assembly fitting (RTA) - It is ready to assemble fitting which is also known as knock down fitting, it come with the assembly of three parts,

- b. Cam - The disk fits into a recess in the first side of the cabinet. It rotates by inserting a screwdriver into the slot in its side. The shaft is screwed into the second side of the cabinet. The collar of the shaft is passed through the hole in the second slot in the disk. When the disk rotates the shaft is locked in position. This keeps both sides of the cabinet locked together.



- c. Connecting Screw – Connecting screw is a cylindrical screw which have two ends and one of the end inserts in the socket and another end inserts in the cam. It is used to connect joint and to give strength to it.

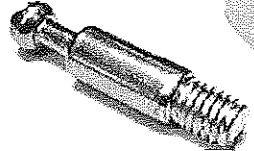

- d. Socket – Socket is assembled in second part of assembly. It is used to provide grip to the connecting screw.





BHARTIYA SKILL DEVELOPMENT UNIVERSITY

Registration No.:

Set – A

School of Woodworking Skills

Session: 2021-22 (Summer Semester)

B. Voc. Program, 3rd Semester,

End Sem. Examination

Course Code: SCS1304

Course Name: Carpenter mathematics

Time: 2 Hour

Max. Marks: 50

Instruction:

- Answer all questions from section A, each question carries one mark.
- Answer all question from section B, each question carries four marks.
- Answer all question from section C, each question carries six marks.

Section – A

10X01 = 10 Marks

Q. 1 Amount required for buying 270 shares, Rs 60 shares at a discount of Rs 10.

- (a) 13500/- (b) 12300/-
(c) 11400/- (d) 11750/-

Q. 2 If a share of NV of Rs 200 is selling at Rs 190 then:

- (a) the share is at a premium of Rs 20. (b) discounted at Rs. 10.
(c) at par. (d) None of these.

Q. 3 General notation of spherical coordinates system is:

- (a) (x, y, z) (b) (r, θ, z)
(c) (r, θ, ϕ) (d) None of these

Q.4 Location of the point (2, 4) and (-7, 8) in Cartesian coordinates:

- (a) I, II quadrants (b) III, IV quadrants
(c) II, III quadrants (d) II, IV quadrants

Q. 5 Amount required for buying 20 shares, Rs 75 quoted at Rs 71.50.

- (a) 1420/- (b) 1430/-
(c) 1530/- (d) 1555/-

Q. 6 The conversion of (4, -1, -8) in cylindrical coordinates represented by:



BHARTIYA SKILL DEVELOPMENT UNIVERSITY

- (a) $(\sqrt{17}, 3.3866, 8)$ (b) $(\sqrt{19}, 4.876, 8)$
(c) $(\sqrt{17}, 8, 3.3866)$ (d) $(\sqrt{17}, -1, 8)$
- Q. 7 General notation for cartesian coordinates system is:
(a) (x, y, z) (b) (r, θ, ϕ)
(c) (r, θ, z) (d) None of these
- Q. 8 $1 + \tan^2 A$ is
(a) $\cot^2 A$ (b) $\sec^2 A$
(c) $\operatorname{Cosec}^2 A$ (d) $\sin^2 A$
- Q. 9 $\frac{\tan 27^\circ}{\cot 63^\circ} =$
(a) 2 (b) 1
(c) 0 (d) None
- Q. 10 The area of a rhombus is 225 cm² and one of the diagonals is 15 cm. The length of another diagonal is
(a) 15 cm (b) 30 cm
(c) 32 cm (d) 12 cm
- Section – B
- 04X04 = 16 Marks
- Q. 11 Show that the points (1, 7), (4, 2), (-1, -1) and (-4, 4) are the vertices of a square.
- Q. 12 Rahul invests Rs 10000 in a company paying a dividend of 6% per annum when a share of NV Rs 100 stands at Rs 200. What is his annual income? If he sells 50% of his shares when the price rises to Rs 250, what is his gain in this transaction?
- Q. 13 Do the points (3, 2), (-2, -3) and (2, 3) form a triangle? If so, name the type of triangle formed.
- Q. 14 Given $\cot A = 3/4$
find the other
trigonometric ratios of the angle A.



BHARTIYA SKILL DEVELOPMENT UNIVERSITY

Section – C

04X06 = 24 Marks

- Q. 15 Convert the following equation written in Cartesian coordinates into an equation in Cylindrical coordinates.

$$x^3 + 2x^2 - 6z = 4 - 2y^2$$

- Q. 16 Write short notes on:

- Dry and wet bulb temperature
- tensile and compressive strength.

- Q. 17 Prove that $\left(\frac{1+\tan^2 A}{1+\cot^2 A}\right) = \left(\frac{1-\tan A}{1-\cot A}\right)^2 = \tan^2 A$

- Q. 18 Consider ΔACB , right-angled at C, in which $AB = 29$ units, $BC = 21$ units and $\angle ABC = \theta$ (see Fig. 8.10). Determine the values of

- $\cos^2 \theta + \sin^2 \theta$
- $\cos^2 \theta - \sin^2 \theta$.

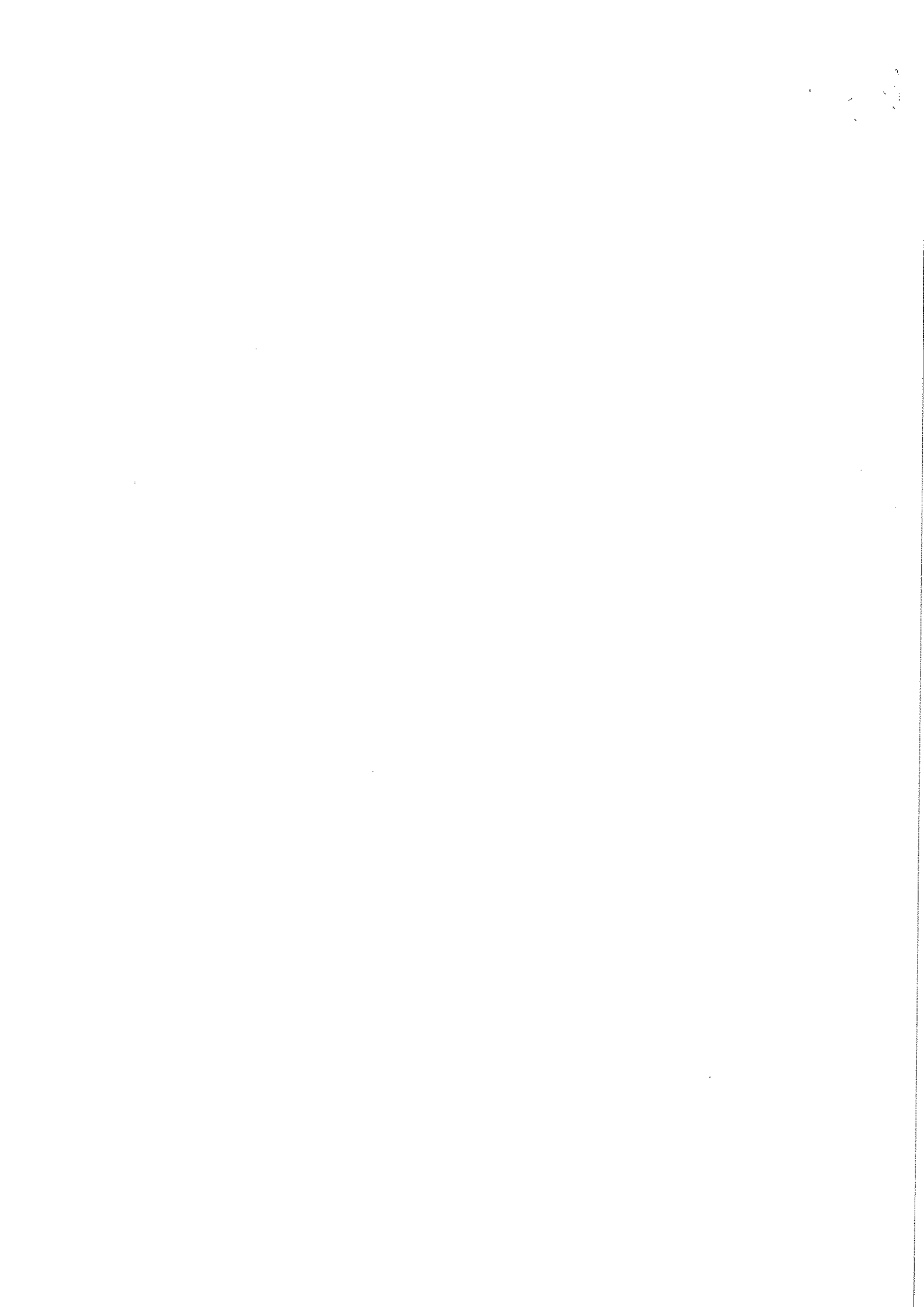



Set – A

School of Woodworking Skills

Session: 2021-22 (Summer Semester)

B. Voc. Program, 3rd Semester,

End Sem. Examination

Course Code: SCS1304

Course Name: Carpenter mathematics

Instruction:

- Answer all questions from section A, each question carries one mark.
- Answer all question from section B, each question carries four marks.
- Answer all question from section C, each question carries six marks.

Time: 2 Hour

Max. Marks: 50

Section – A

10X01 = 10 Marks

Q. 1 Amount required for buying 270 shares, Rs 60 shares at a discount of Rs 10.

- (a) 13500/- (b) 12300/-
(c) 11400/- (d) 11750/-

Ans: (a)

Q. 2 If a share of NV of Rs 200 is selling at Rs 190 then:

- (a) the share is at a premium of Rs 20. (b) discounted at Rs. 10.
(c) at par. (d) None of these.

Ans: (b)

Q. 3 General notation of spherical coordinates system is:

- (a) (x, y, z) (b) (r, θ, z)
(c) (r, θ, ϕ) (d) None of these

Ans: (c)

Q.4 Location of the point (2, 4) and (-7, 8) in Cartesian coordinates:

- (a) I, II quadrants (b) III, IV quadrants
(c) II, III quadrants (d) II, IV quadrants

Ans: (a)

Q. 5 Amount required for buying 20 shares, Rs 75 quoted at Rs 71.50.



BHARTIYA SKILL DEVELOPMENT UNIVERSITY

- (a) 1420/- (b) 1430/-
(c) 1530/- (d) 1555/-

Ans: (b)

Q. 6 The conversion of (4, -1, -8) in cylindrical coordinates represented by:

- (a) $(\sqrt{17}, 3.3866, 8)$ (b) $(\sqrt{19}, 4.876, 8)$
(c) $(\sqrt{17}, 8, 3.3866)$ (d) $(\sqrt{17}, -1, 8)$

Ans: (a)

Q. 7 General notation for cartesian coordinates system is:

- (a) (x,y,z) (b) (r, θ , ϕ)
(c) (r, θ, z) (d) None of these

Q. 8 $1 + \tan^2 A$ is

- (a) $\cot^2 A$ (b) $\sec^2 A$
(c) $\operatorname{cosec}^2 A$ (d) $\sin^2 A$

Q. 9 $\frac{\tan 27^\circ}{\cot 63^\circ} =$

- (a) 2 (b) 1
(c) 0 (d) None

Ans. (b)

Q. 10 The area of a rhombus is 225 cm² and one of the diagonals is 15 cm. The length of another diagonal is

- (a) 15 cm (b) 30 cm
(c) 32 cm (d) 12 cm

Ans. b)

Section – B

04X04 = 16 Marks

Q. 11 Show that the points (1, 7), (4, 2), (-1, -1) and (-4, 4) are the vertices of a square.

Solution:

Let A(1, 7), B(4, 2), C(-1, -1) and D(-4, 4) be the given points. One way of showing that ABCD is a square is to use the property that all its sides should be equal and both its diagonals should also be equal. Now,



BHARTIYA SKILL DEVELOPMENT UNIVERSITY

$$AB = \sqrt{(1-4)^2 + (7-2)^2} = \sqrt{9+25} = \sqrt{34}$$

$$BC = \sqrt{(4+1)^2 + (2+1)^2} = \sqrt{25+9} = \sqrt{34}$$

$$CD = \sqrt{(-1+4)^2 + (-1-4)^2} = \sqrt{9+25} = \sqrt{34}$$

$$DA = \sqrt{(1+4)^2 + (7-4)^2} = \sqrt{25+9} = \sqrt{34}$$

$$AC = \sqrt{(1+1)^2 + (7+1)^2} = \sqrt{4+64} = \sqrt{68}$$

$$BD = \sqrt{(4+4)^2 + (2-4)^2} = \sqrt{64+4} = \sqrt{68}$$

Since, $AB = BC = CD = DA$ and $AC = BD$, all the four sides of the quadrilateral ABCD are equal and its diagonals AC and BD are also equal. Therefore, ABCD is a square.

Q. 12 Rahul invests Rs 10000 in a company paying a dividend of 6% per annum when a share of NV Rs 100 stands at Rs 200. What is his annual income? If he sells 50% of his shares when the price rises to Rs 250, what is his gain in this transaction?

Ans

No. of shares bought by Rahul $((Investment)/MV)=10000/200=50$

His annual income on 1 share=6% of NV=6% of Rs 100= Rs 6

His total annual income= $(50 \times Rs 6) = Rs 300$

Since, 50% of shares= 50% of 50 =25

Money received on selling these shares = $(25 \times Rs 250) = Rs 6250$

Also, cost of these shares = $(25 \times Rs 200) = Rs 5000$

Therefore, Mukul's gain = $Rs (6250-5000) = Rs 1250$

Q. 13 Do the points (3, 2), (-2, -3) and (2, 3) form a triangle? If so, name the type of triangle formed.

Solution: Let us apply the distance formula to find the distances PQ, QR and PR, where P(3, 2), Q(-2, -3) and R(2, 3) are the given points. We have



BHARTIYA SKILL DEVELOPMENT UNIVERSITY

$$PQ = \sqrt{(3+2)^2 + (2+3)^2} = \sqrt{5^2 + 5^2} = \sqrt{50} = 7.07 \text{ (approx.)}$$

$$QR = \sqrt{(-2-2)^2 + (-3-3)^2} = \sqrt{(-4)^2 + (-6)^2} = \sqrt{52} = 7.21 \text{ (approx.)}$$

$$PR = \sqrt{(3-2)^2 + (2-3)^2} = \sqrt{1^2 + (-1)^2} = \sqrt{2} = 1.41 \text{ (approx.)}$$

Since the sum of any two of these distances is greater than the third distance, therefore, the points P, Q and R form a triangle.

Q. 14 Given $\cot A = 3/4$
find the other
trigonometric ratios of the angle A.

Ans.

Therefore, if $BC = 4k$, then $AB = 3k$, where k is a positive number.

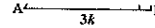

Fig. 8.8

Now, by using the Pythagoras Theorem, we have

$$AC^2 = AB^2 + BC^2 = (4k)^2 + (3k)^2 = 25k^2$$

So, $AC = 5k$

Now, we can write all the trigonometric ratios using their definitions.

$$\sin A = \frac{BC}{AC} = \frac{4k}{5k} = \frac{4}{5}$$

$$\cos A = \frac{AB}{AC} = \frac{3k}{5k} = \frac{3}{5}$$

Therefore, $\cot A = \frac{1}{\tan A} = \frac{3}{4}$, $\operatorname{cosec} A = \frac{1}{\sin A} = \frac{5}{4}$ and $\sec A = \frac{1}{\cos A} = \frac{5}{3}$.

Section – C

04X06 = 24 Marks

Q. 15 Convert the following equation written in Cartesian coordinates into an equation in Cylindrical coordinates.

$$x^3 + 2x^2 - 6z = 4 - 2y^2$$

Solution:

$$x = r \cos \theta, \quad y = r \sin \theta \quad r^2 = x^2 + y^2$$

Using these values of x , y , and r

$$x^3 + 2x^2 + 2y^2 - 6z = 4 \quad \rightarrow \quad x^3 + 2(x^2 + y^2) - 6z = 4$$

$$r^3 \cos^3 \theta + 2r^2 - 6z = 4$$

Q. 16 Write short notes on:

- a) Dry and wet bulb temperature
- b) tensile and compressive strength.

Solution:



BHARTIYA SKILL DEVELOPMENT UNIVERSITY

a) **Dry bulb temperature** It is the temperature of air recorded by a thermometer, when it is not affected by the moisture present in the air. The dry bulb temperature (briefly written as DBT) is generally denoted by t_d or t_{db} . **Wet bulb temperature** It is the temperature of air recorded by a thermometer, when its bulb is surrounded by a wet cloth exposed to the air. Such a thermometer is called *wet bulb thermometer. The wet bulb temperature (briefly written as WBT) is generally denoted by t_w or t_{wb} . At 100% relative humidity, the wet-bulb temperature is equal to the air temperature (dry-bulb temperature) and is lower at lower humidity.

b) **Tensile strength** :The tensile strength of wood parallel to the grain depends upon the strength of the fibers and is affected not only by the nature and dimensions of the wood elements but also by their arrangement. **Compressive or crushing strength** :Is very closely related to hardness and transverse shear. There are two ways in which wood is subjected to stress of this kind, namely, (1) with the load acting over the entire area of the specimen, and (2) with a load concentrated over a portion of the area.

Q. 17 Prove that $\left(\frac{1+\tan^2 A}{1+\cot^2 A}\right) = \left(\frac{1-\tan A}{1-\cot A}\right)^2 = \tan^2 A$

Solution:

$$\begin{aligned} \text{LHS} &= \frac{1+\tan^2 A}{1+\cot^2 A} = \frac{\sec^2 A}{\operatorname{cosec}^2 A} = \frac{\frac{1}{\cos^2 A}}{\frac{1}{\sin^2 A}} \\ &= \frac{\sin^2 A}{\cos^2 A} = \tan^2 A. \\ \text{RHS} &= \left(\frac{1-\tan A}{1-\cot A}\right)^2 = \left(\frac{1-\frac{\sin A}{\cos A}}{1-\frac{\cos A}{\sin A}}\right)^2 \\ &= \left(\frac{\frac{\cos A - \sin A}{\cos A}}{\frac{\sin A - \cos A}{\sin A}}\right)^2 \\ &= \frac{(\cos A - \sin A)^2 \times \sin^2 A}{(\sin A - \cos A)^2 \times \cos^2 A} \\ &= \frac{(\sin A - \cos A)^2 \times \sin^2 A}{(\sin A - \cos A)^2 \times \cos^2 A} \\ &= \frac{\sin^2 A}{\cos^2 A} = \tan^2 A. \end{aligned}$$

$\therefore \text{LHS} = \text{RHS}$ Hence, **proved**.

Q. 18 Consider ΔACB , right-angled at C, in which $AB = 29$ units, $BC = 21$ units and $\angle ABC = \theta$ (see Fig. 8.10). Determine the values of

(i) $\cos^2 \theta + \sin^2 \theta$

(ii) $\cos^2 \theta - \sin^2 \theta$.

Ans.



BHARTIYA SKILL DEVELOPMENT UNIVERSITY

$$\begin{aligned} AC &= \sqrt{AB^2 - BC^2} = \sqrt{(29)^2 - (21)^2} && \text{21} \\ &= \sqrt{(29 - 21)(29 + 21)} = \sqrt{(8)(50)} = \sqrt{400} = 20 \text{ units} && \text{Fig. 8.10} \end{aligned}$$

So, $\sin \theta = \frac{AC}{AB} = \frac{20}{29}$, $\cos \theta = \frac{BC}{AB} = \frac{21}{29}$.

Now, (i) $\cos^2 \theta + \sin^2 \theta = \left(\frac{21}{29}\right)^2 + \left(\frac{20}{29}\right)^2 = \frac{21^2 + 20^2}{29^2} = \frac{441 + 400}{841} = 1$,

and (ii) $\cos^2 \theta - \sin^2 \theta = \left(\frac{21}{29}\right)^2 - \left(\frac{20}{29}\right)^2 = \frac{(21 + 20)(21 - 20)}{29^2} = \frac{41}{841}$.



BHARTIYA SKILL DEVELOPMENT UNIVERSITY

Registration No.:

Set – B

School of Woodworking Skills

Session: 2021-22 (Summer Semester)

B. Voc. Program, 3rd Semester,

End Sem. Examination

Course Code: SCS1304

Course Name: Carpenter mathematics

Time: 2 Hour

Max. Marks: 50

Instruction:

- Answer all questions from section A, each question carries one mark.
- Answer all question from section B, each question carries four marks.
- Answer all question from section C, each question carries six marks.

Section A

10X01 = 10 Marks

Q. 1 The plane which consists of two number lines that intersect each other at right angle is called:

- | | |
|----------------------|-----------------------|
| (a) Functional plane | (b) Cartesian plane |
| (c) Ordinate plane | (d) Dimensional plane |

Q. 2 General notation for Cartesian coordinates system is:

- | | |
|----------------------|-------------------------|
| (a) (x, y, z) | (b) (r, θ, ϕ) |
| (c) (r, θ, z) | (d) None of these |

Q. 3 If a share of NV of Rs 20 is selling at Rs 36 then:

- | | |
|---|--------------------------|
| (a) the share is at a premium of Rs 16. | (b) discounted at Rs.16. |
| (c) at par. | (d) None of these. |

Q. 4 Location of the point $(-2, 4)$ and $(-8, -8)$ in cartesian coordinates:



BHARTIYA SKILL DEVELOPMENT UNIVERSITY

- (a) I, II quadrants
(b) III, IV quadrants
(c) II, III quadrants
(d) II, IV quadrants
- Q. 5 A flooring tile has the shape of a parallelogram whose base is 24 cm and the corresponding height is 10 cm. How many such tiles are required to cover a floor of area 1080 m²?
- (a) 15000
(b) 30000
(c) 45000
(d) 12000
- Q. 6 The lateral surface area of sphere is
- (a) $4\pi r^2$
(b) $4\pi r$
(c) $2\pi r^2$
(d) πr^2
- Q. 7 The property of material by virtue of which it can resist the abrasion and scratches
- (a) Ductility
(b) Hardness
(c) Malleability
(d) Stiffness
- Q. 8 The oak wood has a mass of 164 kg and a volume of 194 dm³ What is the density?
- (a) 1.44 kg/dm³
(b) 0.69 kg/dm³
(c) 0.84 kg/dm³
(d) 1.34 kg/dm³
- Q. 9 $\sec(90-A)$ is
- (a) $\sin A$
(b) $\tan A$
(c) $\operatorname{cosec} A$
(d) None
- Q. 10 The a relation between x and y if the point (x, y) is equidistant from the points (7, 1) and (3, 5).
- (a) $x-y=5$
(b) $x-y=2$
(c) $x+y=2$
(d) $x+y=5$

Section B

04X04 = 16 Marks



BHARTIYA SKILL DEVELOPMENT UNIVERSITY

- Q. 11 Write short notes on:
- Dry and wet bulb temperature
 - tensile and compressive strength.
- Q. 12 Rahul invests Rs 10000 in a company paying a dividend of 6% per annum when a share of NV Rs 100 stands at Rs 200. What is his annual income? If he sells 50% of his shares when the price rises to Rs 250, what is his gain in this transaction?
- Q. 13 Find a relation between x and y such that the point (x, y) is equidistant from the points $(8, 1)$ and $(4, 5)$.
- Q. 14 Given $\tan A = 4/3$
find the other
trigonometric ratios of the angle A .

Section C

04X06 = 24 Marks

- Q. 15 Explain the influence of moisture on mechanical properties of wood-based products.
- Q. 16 Robert bought shares of 6% \$ 100 shares at \$ 120. Adrian bought shares of 8% \$ 20 shares at \$ 30. Whose investment was better?
- Q. 17 In a building there are 24 cylindrical pillars. The radius of each pillar is 28 cm and height is 4 m. Find the total cost of painting the curved surface area of all pillars at the rate of INR 8 per m^2 .
- Q. 18 Consider ΔACB , right-angled at C , in which $AB = 29$ units, $BC = 21$ units and $\angle ABC = \theta$ (see Fig. 8.10). Determine the values of
- $\cos^2 \theta + \sin^2 \theta$
 - $\cos^2 \theta - \sin^2 \theta$.

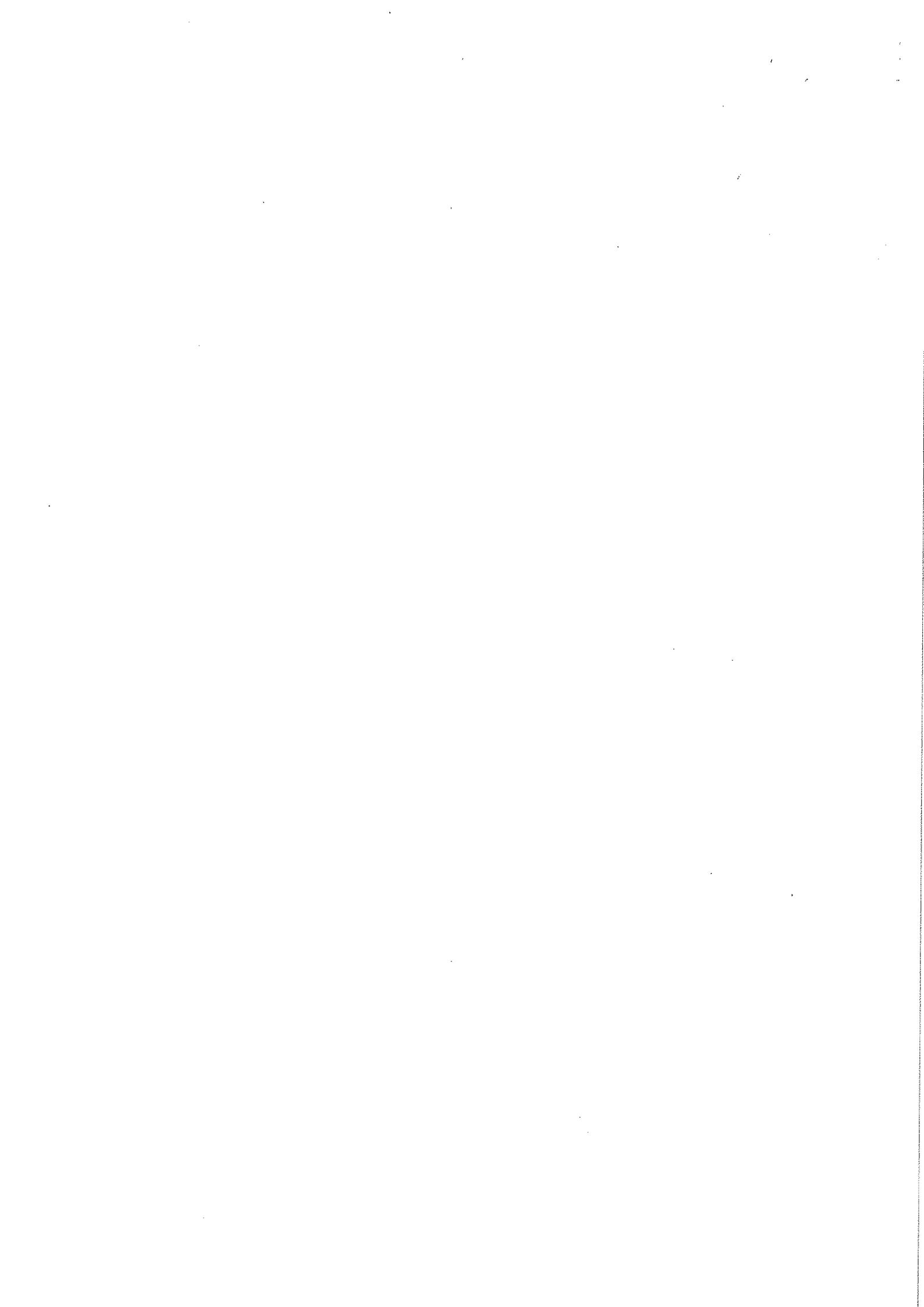



BHARTIYA SKILL DEVELOPMENT UNIVERSITY

Answer key

Set – B

School of Woodworking Skills

Session: 2021-22 (Summer Semester)

B. Voc. Program, 3rd Semester,

End Sem. Examination

Course Code: SCS1304

Course Name: Carpenter mathematics

Time: 2 Hour

Max. Marks: 50

Instruction:

- Answer all questions from section A, each question carries one mark.
- Answer all question from section B, each question carries four marks.
- Answer all question from section C, each question carries six marks.

Section A

10X01 = 10 Marks

Q. 1 The plane which consists of two number lines that intersect each other at right angle is called:

(a) Functional plane

(b) Cartesian plane

(c) Ordinate plane

(d) Dimensional plane

Ans: (b)

Q. 2 General notation for Cartesian coordinates system is:

(a) (x, y, z)

(b) (r, θ, ϕ)

(c) (r, θ, z)

(d) None of these

Ans: (a)

Q. 3 If a share of NV of Rs 20 is selling at Rs 36 then:

(a) the share is at a premium of Rs 16.

(b) discounted at Rs.16.

(c) at par.

(d) None of these.

Ans: (a)



BHARTIYA SKILL DEVELOPMENT UNIVERSITY

Q. 4 Location of the point (-2, 4) and (-8, -8) in cartesian coordinates:

- (a) I, II quadrants (b) III, IV quadrants
(c) II, III quadrants (d) II, IV quadrants

Ans: (c)

Q. 5 A flooring tile has the shape of a parallelogram whose base is 24 cm and the corresponding height is 10 cm. How many such tiles are required to cover a floor of area 1080 m²?

- (a) 15000 (b) 30000
(c) 45000 (d) 12000

Ans.

Q. 6 The lateral surface area of sphere is

- (a) $\frac{4\pi r^2}{2}$ (b) $4\pi r$
(c) $2\pi r^2$ (d) πr^2

Ans. a

Q. 7 The property of material by virtue of which it can resist the abrasion and scratches

- (a) Ductility (b) Hardness
(c) Malleability (d) Stiffness

Ans. (b)

Q. 8 The oak wood has a mass of 164 kg and a volume of 194 dm³ What is the density?

- (a) 1.44 kg/dm³ (b) 0.69 kg/dm³
(c) 0.84 kg/dm³ (d) 1.34 kg/dm³

Q. 9 $\sec(90-A)$ is

- (a) $\sin A$ (b) $\tan A$
(c) $\operatorname{cosec} A$ (d) None

Ans. (c)



BHARTIYA SKILL DEVELOPMENT UNIVERSITY

Q. 10 The a relation between x and y if the point (x , y) is equidistant from the points (7, 1) and (3, 5).

(a) $x-y=5$

(b) $x-y=2$

(c) $x+y=2$

(d) $x+y=5$

Section B

04X04 = 16 Marks

Q. 11 Write short notes on: a) Dry and wet bulb temperature b) tensile and compressive strength.

Solution:

a) Dry bulb temperature It is the temperature of air recorded by a thermometer, when it is not affected by the moisture present in the air. The dry bulb temperature (briefly written as DBT) is generally denoted by t_d or t_{db} . Wet bulb temperature It is the temperature of air recorded by a thermometer, when its bulb is surrounded by a wet cloth exposed to the air. Such a thermometer is called *wet bulb thermometer. The wet bulb temperature (briefly written as WBT) is generally denoted by t_w or t_{wb} . At 100% relative humidity, the wet-bulb temperature is equal to the air temperature (dry-bulb temperature) and is lower at lower humidity.

b) Tensile strength :The tensile strength of wood parallel to the grain depends upon the strength of the fibers and is affected not only by the nature and dimensions of the wood elements but also by their arrangement. Compressive or crushing strength :Is very closely related to hardness and transverse shear. There are two ways in which wood is subjected to stress of this kind, namely, (1) with the load acting over the entire area of the specimen, and (2) with a load concentrated over a portion of the area.

Q. 12 Rahul invests Rs 10000 in a company paying a dividend of 6% per annum when a share of NV Rs 100 stands at Rs 200. What is his annual income? If he sells 50% of his shares when the price rises to Rs 250, what is his gain in this transaction?

Ans

No. of shares bought by Rahul $((Investment)/MV)=10000/200=50$

His annual income on 1 share=6% of NV=6% of Rs 100= Rs 6



BHARTIYA SKILL DEVELOPMENT UNIVERSITY

His total annual income = $(50 \times \text{Rs } 6) = \text{Rs } 300$

Since, 50% of shares = 50% of 50 = 25

Money received on selling these shares = $(25 \times \text{Rs } 250) = \text{Rs } 6250$

Also, cost of these shares = $(25 \times \text{Rs } 200) = \text{Rs } 5000$

Therefore, Mukul's gain = $\text{Rs } (6250 - 5000) = \text{Rs } 1250$

Q. 13 Find a relation between x and y such that the point (x, y) is equidistant from the points $(8, 1)$ and $(4, 5)$.

Solution: Let $P(x, y)$ be equidistant from the points $A(7, 1)$ and $B(3, 5)$.

We are given that $AP = BP$. So, $AP^2 = BP^2$

$$\text{i.e., } (x - 8)^2 + (y - 1)^2 = (x - 4)^2 + (y - 5)^2$$

$$\text{i.e., } x^2 - 16x + 64 + y^2 - 2y + 1 = x^2 - 8x + 16 + y^2 - 10y + 25$$

$$\text{i.e., } x - y = 3$$

Q. 14 Given $\tan A = 4/3$
find the other
trigonometric ratios of the angle A .

Ans.

Therefore, if $BC = 4k$, then $AB = 3k$, where k is a positive number.

Now, by using the Pythagoras Theorem, we have

$$AC^2 = AB^2 + BC^2 = (4k)^2 + (3k)^2 = 25k^2$$

So,

$$AC = 5k$$

Now, we can write all the trigonometric ratios using their definitions.

$$\sin A = \frac{BC}{AC} = \frac{4k}{5k} = \frac{4}{5}$$

$$\cos A = \frac{AB}{AC} = \frac{3k}{5k} = \frac{3}{5}$$

$$\text{Therefore, } \cot A = \frac{1}{\tan A} = \frac{3}{4}, \text{ cosec } A = \frac{1}{\sin A} = \frac{5}{4} \text{ and } \sec A = \frac{1}{\cos A} = \frac{5}{3}.$$

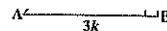

Fig. 8.8



BHARTIYA SKILL DEVELOPMENT UNIVERSITY

Section C

04X06 = 24 Marks

Q. 15 Explain the influence of moisture on mechanical properties of wood-based products.

Solution:

Wood is a material that continually absorbs or releases moisture until it reaches a balance with its surroundings. In normal use the moisture content of wood varies between 8% and 25% by weight, depending on the relative humidity of the air. On the other hand, an excess of moisture in wood can cause other problems, including, but not limited to: Preventing adhesives from making a secure bond (Less strength) and Shrinkage as the excess moisture leaves the wood:

Shrinkage occurs as moisture content decreases, while swelling takes place when it increases. Volume change is not equal in all directions. The greatest dimensional change occurs in a direction tangential to the growth rings. Shrinkage from the pith outwards, or radially, is usually considerably less than tangential shrinkage, while longitudinal (along the grain) shrinkage is so slight as to be usually neglected. The longitudinal shrinkage is 0.1% to 0.3%, in contrast to transverse shrinkages, which is 2% to 10%. Tangential shrinkage is often about twice as great as in the radial direction, although in some species it is as much as five times as great. The shrinkage is about 5% to 10% in the tangential direction and about 2% to 6% in the radial direction.

Q. 16 Robert bought shares of 6% \$ 100 shares at \$ 120. Adrian bought shares of 8% \$ 20 shares at \$ 30. Whose investment was better?

Solution:



BHARTIYA SKILL DEVELOPMENT UNIVERSITY

6% \$ 100 shares at \$ 120

i.e., the annual income from 1 share of nominal value \$ 100 is \$ 6, investment for 1 share being \$ 120.

Therefore, profit percentage = $\frac{6}{120} \times 100 \% = 5\%$

Therefore, Robert's shares give him a profit of 5%

8 % \$ 20 shares at \$ 30

i.e., the annual income from 1 share of nominal value \$ 20 is \$ $\frac{8 \times 20}{100} = \$ \frac{8}{5}$, investment for 1 share being \$ 30.

$$\begin{aligned}\text{Profit percentage} &= \frac{\$ \frac{8}{5}}{\$ 30} \times 100 \% \\ &= \frac{16}{3} \% \\ &= 5\frac{1}{3} \%\end{aligned}$$

Therefore, Adrian's shares give him a profit of $5\frac{1}{3}\%$

Therefore, Adrian's investment was better.

- Q. 17** In a building there are 24 cylindrical pillars. The radius of each pillar is 28 cm and height is 4 m. Find the total cost of painting the curved surface area of all pillars at the rate of INR 8 per m^2 .

Solution:

Radius of cylindrical pillar, $r = 28 \text{ cm} = 0.28 \text{ m}$

height, $h = 4 \text{ m}$

curved surface area of a cylinder = $2\pi rh$

curved surface area of a pillar = $2 \times \frac{22}{7} \times 0.28 \times 4 = 7.04 \text{ m}^2$

curved surface area of 24 such pillar = $7.04 \times 24 = 168.96 \text{ m}^2$

cost of painting an area of $1 \text{ m}^2 = ₹ 8$

Therefore, cost of painting $1689.6 \text{ m}^2 = 168.96 \times 8 = ₹ 1351.68$

- Q. 18** Consider ΔACB , right-angled at C, in which $AB = 29$ units, $BC = 21$ units and $\angle ABC = \theta$ (see Fig. 8.10). Determine the values of

(i) $\cos^2 \theta + \sin^2 \theta$

(ii) $\cos^2 \theta - \sin^2 \theta$.

Ans.



BHARTIYA SKILL DEVELOPMENT UNIVERSITY

$$\begin{aligned} AC &= \sqrt{AB^2 - BC^2} = \sqrt{(29)^2 - (21)^2} && \text{41} \\ &= \sqrt{(29 - 21)(29 + 21)} = \sqrt{(8)(50)} = \sqrt{400} = 20 \text{ units} && \text{Fig. 8.10} \end{aligned}$$

$$\text{So, } \sin \theta = \frac{AC}{AB} = \frac{20}{29}, \cos \theta = \frac{BC}{AB} = \frac{21}{29}$$

$$\text{Now, (i) } \cos^2 \theta + \sin^2 \theta = \left(\frac{20}{29}\right)^2 + \left(\frac{21}{29}\right)^2 = \frac{20^2 + 21^2}{29^2} = \frac{400 + 441}{841} = 1,$$

$$\text{and (ii) } \cos^2 \theta - \sin^2 \theta = \left(\frac{21}{29}\right)^2 - \left(\frac{20}{29}\right)^2 = \frac{(21 + 20)(21 - 20)}{29^2} = \frac{41}{841}$$

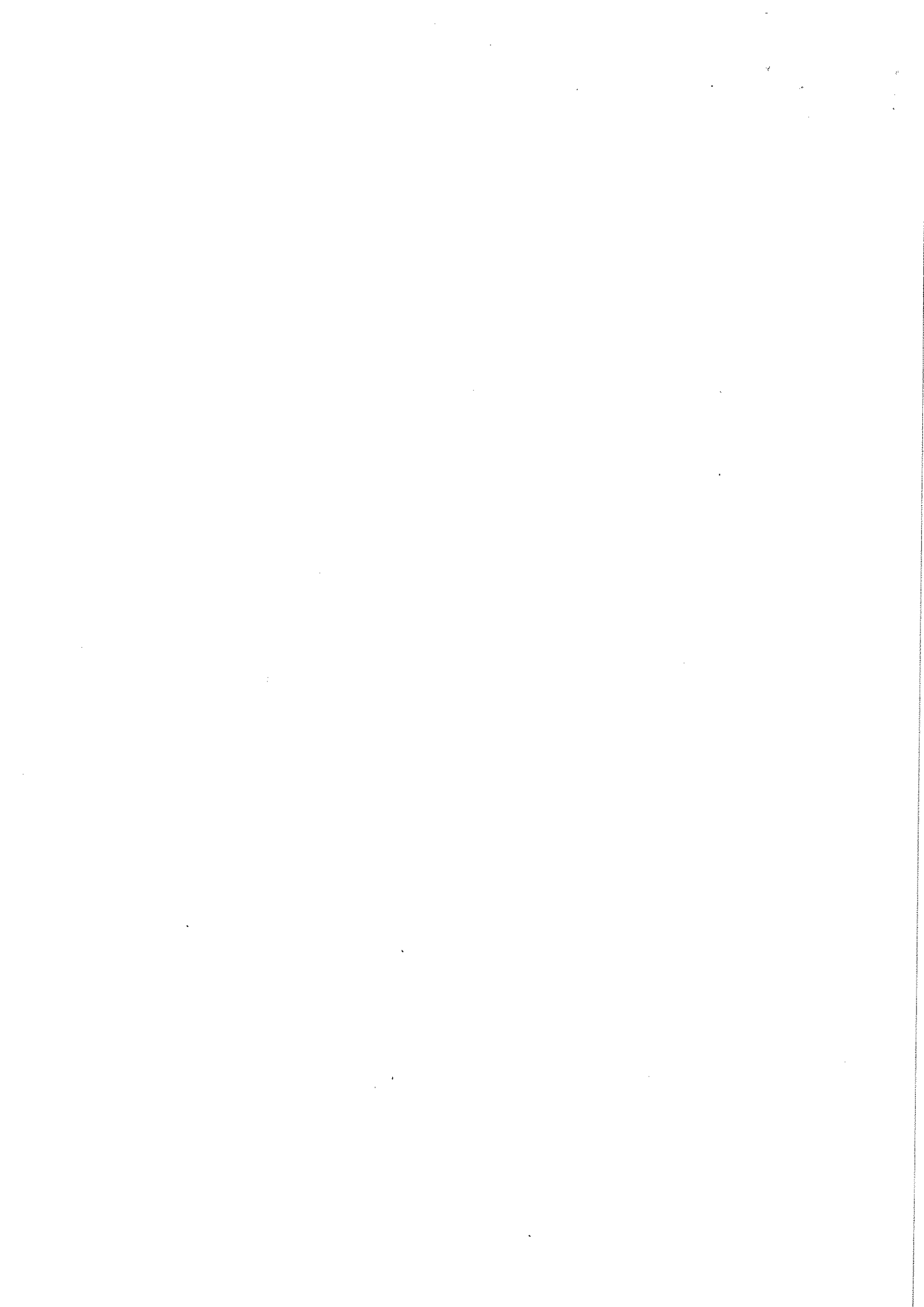



BHARTIYA SKILL DEVELOPMENT UNIVERSITY

Registration No.:

Set – A

School of Woodworking Skills
Session: 2021-22 (Summer Semester)
B. Voc. Program, 3rd Semester,
End-Sem. Examination

Course Code: SCS1305

Time: 2 Hours

Course Name: Wood working CNC Machine

Max. Marks: 50

Instruction:

- All questions from section A, each question carries one marks.
- All questions from section B, each question carries four marks.
- All questions from section C, each question carries six marks.

Section – A

10X01 = 10 Marks

- Q.1 Glue application unit applies glue to which of the following in Edge banding machine?
(a) Both work piece and edge banding tape (b) Work piece
(c) Edge banding tape (d) All of them
- Q.2 What is the compressed air pressure consumption in the tempora F600?
(a) 6-7 bar (b) 5-6 bar
(c) 4-5 bar (d) 7-8 bar
- Q.3 Which one of the following is the diameter of the grooving saw in Profit H 300 CNC router?
(a) Ø125 mm (b) Ø175 mm
(c) Ø150 mm (d) None of these
- Q.4 How many axes have in CNC router Profit H300?
(a) 2 (b) 6
(c) 5 (d) 3
- Q.5 CNC router Profit H300 have a main head for milling tool is true or false?
(a) True (b) False
- Q.6 How many work stations have in CNC router Profit H300?
(a) 4 (b) 2
(c) 3 (d) None of these
- Q.7 What is the cutting direction of vertical panel saw?
(a) Right to Left (b) Left to Right
(c) Both A&B (d) None of these
- Q.8 Which one of the following material can't be cut on vertical panel saw?
(a) MDF (b) HDF
(c) Solid wood (d) None of these



BHARTIYA SKILL DEVELOPMENT UNIVERSITY

Q.9 Which one of the following is a property of the pre-milling Unit/aggregate in Edge banding machine?

- (a) Trim the edge
- (b) Cut the length
- (c) Clean extra material
- (d) Rounding the edges

Q.10 Which one of the following glue types is used in the Edge banding machine?

- (a) Water based glue
- (b) PUR
- (c) Hot melt glue
- (d) Contact glue

Section – B

04X04 = 16 Marks

Q.11 Write the overview of Vertical Saw machine?

Q.12 Why Edge banding is required at the edge of work piece?

Q.13 What does the term CNC stands for?

Q.14 Explain the Safety Carpet? Why we required in CNC router machine?

Section – C

04X06 = 24 Marks

Q.15 How does Suction cup works in CNC router machine?

Q.16 Explain difference between Stationary machine and CNC machine?

Q.17 Write the overview of CNC Edge Band machine?

Q.18 Write the name of Edge banding stages?



BHARTIYA SKILL DEVELOPMENT UNIVERSITY

Answer key

Set – A

School of Woodworking Skills
Session: 2021-22 (Summer Semester)
B. Voc. Program, 3rd Semester,
End-Sem. Examination

Course Code: SCS1305

Time: 2 Hours

Course Name: Wood working CNC Machine

Max. Marks: 50

Instruction:

- All questions from section A, each question carries one marks.
- All questions from section B, each question carries four marks.
- All questions from section C, each question carries six marks.

Section – A

10X01 = 10 Marks

- Q.1 Glue application unit applies glue to which of the following in Edge banding machine?
(a) Both work piece and edge banding tape (b) Work piece
(c) Edge banding tape (d) All of them (b)
- Q.2 What is the compressed air pressure consumption in the tempora F600?
(a) 6-7 bar (b) 5-6 bar
(c) 4-5 bar (d) 7-8 bar (a)
- Q.3 Which one of the following is the diameter of the grooving saw in Profit H 300 CNC router?
(a) Ø125 mm (b) Ø175 mm
(c) Ø150 mm (d) None of these (a)
- Q.4 How many axes have in CNC router Profit H300?
(a) 2 (b) 6
(c) 5 (d) 3 (d)
- Q.5 CNC router Profit H300 have a main head for milling tool is true or false?
(a) True (b) False (a)
- Q.6 How many work stations have in CNC router Profit H300?
(a) 4 (b) 2
(c) 3 (d) None of these (a)
- Q.7 What is the cutting direction of vertical panel saw?
(a) Right to Left (b) Left to Right
(c) Both A&B (d) None of these (b)
- Q.8 Which one of the following material can't be cut on vertical panel saw?
(a) MDF (b) HDF
(c) Solid wood (d) None of these (c)



BHARTIYA SKILL DEVELOPMENT UNIVERSITY

Q.9 Which one of the following is a property of the pre-milling Unit/aggregate in Edge banding machine?

- (a) Trim the edge (b) Cut the length
(c) Clean extra material (d) Rounding the edges (a)

Q.10 Which one of the following glue types is used in the Edge banding machine?

- (a) Water based glue (b) PUR
(c) Hot melt glue (d) Contact glue (c)

Section – B

04X04 = 16 Marks

Q.11 Write the overview of Vertical Saw machine?

Ans. A vertical panel saw requires less floor space and hence is a preferred choice for many. The two rivals of panel saw are table saw and track saw. Having a vertical wall saw that can handle large sheet sizes allows them to operate a smaller capacity table saw, again saving valuable workshop space. It is not just wood based panels that can be cut. Increasingly plastics, composites and non-ferrous.

Q.12 Why Edge banding is required at the edge of work piece?

Ans. 1. Protect its sides and edges from moisture, humidity and water.
2. Give it a better appearance.
3. Protect its edges from broken.

Q.13 What does the term CNC stands for?

Ans. CNC means **Computer Numerical Control**. This means a computer convert the design produced by Computer Aided Design software (CAD), into numbers. The numbers can be considered to be the coordinates of a graph and they control the movement of the cutter. In this way the computer controls the cutting and shaping of the material.

Q.14 Explain the Safety Carpet? Why we required in CNC router machine?

Ans. CNC machines are built with the proper safety devices in place. These may include guards and other protective devices; it is important that these safety devices are firmly fitted in place at all times while the machine is in use. The CNC carpet is work like an emergency while the machine is working and same time have any mistake by machine and by work piece that time the safety carpet is work like a stop emergency button.

Section – C

04X06 = 24 Marks

Q.15 How does Suction cup works in CNC router machine?

Ans. Working of the suction cup is to clamp the work piece tightly. It ensures that the suction cups are placed on the suction holes of the vacuum pump to get proper suction, vacuum pump is connected with the suction holes with pipes to provide 6-7 bar suction pressure. It is compulsory to switch ON the vacuum pump before working on the CNC router for clamping of the work piece. The vacuum of the suction cups for the clamping purpose can only be created on a plan and smooth surface.

Q.16 Explain difference between Stationary machine and CNC machine?

Ans.



BHARTIYA SKILL DEVELOPMENT UNIVERSITY

Stationary machines	CNC machines
Manually working machines	It works automatically.
Manually tool changing.	Automatically tool changer.
Time consuming	Time saving
Require more man power	Require less man power.
No requirement of software for operation.	It require software for operation.
Low cost	High cost
Require less skill.	Require more skill.
It consumes less space.	It consumes more space.

Q.17 Write the overview of CNC Edge Band machine?

Ans. The machine that applies the edge banding is called edge bander. An edge bander bonds the edge banding to the substrate, trims the leading and trailing edges, trims top and bottom flush with the substrate, scraps any surplus, and buffs the finished edge.

Q.18 Write the name of Edge banding stages?

Ans.

1. Premiling unit
2. Infrared lamp
3. Edge feed
4. Pressure unit
5. End trimming unit
6. Cutting angle
7. Lubricating agent spraying unit
8. Upper multifunctional trimming unit
9. Lower multifunctional trimming unit
10. Corner rounding unit
11. Radius scraping unit
12. Glue scraper
13. Buffing unit

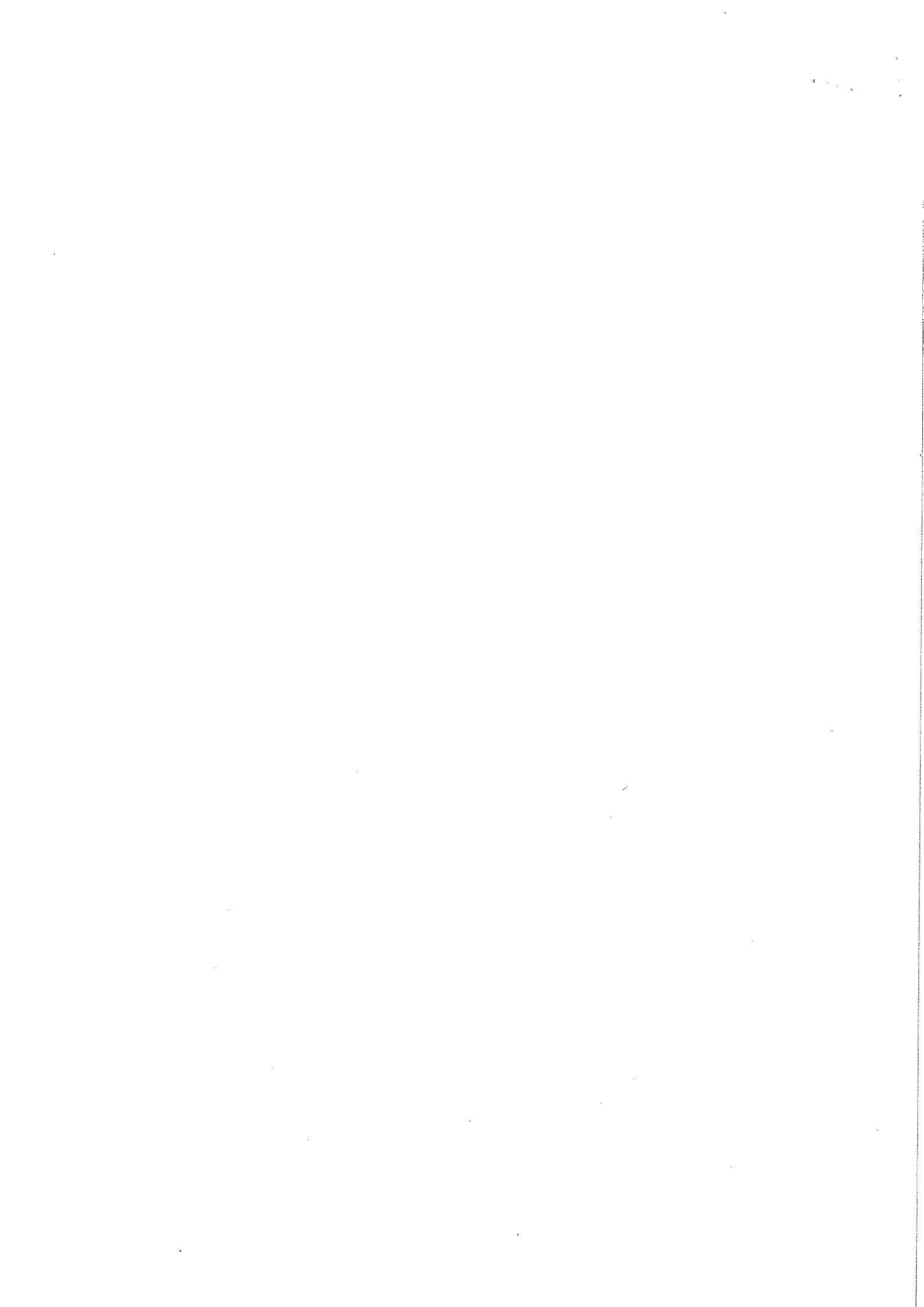



BHARTIYA SKILL DEVELOPMENT UNIVERSITY

Registration No.:

Set –B

School of Woodworking Skills
Session: 2021-22 (Summer Semester)
B. Voc. Program, 3rd Semester,
End-Sem. Examination

Course Code: SCS1305

Time: 2 Hours

Course Name: Wood working CNC Machine

Max. Marks: 50

Instruction:

- All questions from section A, each question carries one marks.
- All questions from section B, each question carries four marks.
- All questions from section C, each question carries six marks.

Section – A

10X01 = 10 Marks

Q.1 Glue application unit applies glue to which of the following in Edge banding machine?

- (a) Both work piece and edge banding tape (b) Work piece
(c) Edge banding tape (d) All of them

Q.2 What is the compressed air pressure consumption in the tempora F600?

- (a) 8-9 bar (b) 5-6 bar
(c) 4-5 bar (d) None of these

Q.3 Which one of the following is the diameter of the grooving saw in Profit H 300 CNC router?

- (a) Ø125 mm (b) Ø175 mm
(c) Ø150 mm (d) None of these

Q.4 How many axis have in CNC router Profit H300?

- (a) 2 (b) 6
(c) 5 (d) None of these

Q.5 CNC router Profit H300 have a Drill head for drilling and sawing is true or false?

- (a) True (b) False

Q.6 How many work stations have in CNC router Profit H300?

- (a) 4 (b) 2
(c) 3 (d) None of these

Q.7 Left to Right is the cutting direction of vertical panel saw is true or false?

- (a) False (b) True

Q.8 Which one of the following material cut on vertical panel saw?

- (a) MDF (b) HDF
(c) Both A&B (d) None of these



BHARTIYA SKILL DEVELOPMENT UNIVERSITY

Q.9 Which one of the following is a property of the End Trimming Unit in Edge banding machine?

- (a) Trim the edge (b) Cut the length
(c) Clean extra material (d) None of these

Q.10 Which type of glue used in the Edge banding machine?

- (a) Water based glue (b) PUR
(c) Hot melt glue (d) Contact glue

Section – B

04X04 = 16 Marks

Q.11 What is the Vertical Saw machine?

Q.12 what is the edge banding? & write the type and size of edge band.

Q.13 What does the term CNC stands for?

Q.14 How many faces we have in CNC router machine for machining, make a diagram and indicate the faces?

Section – C

04X06 = 24 Marks

Q.15 What is the work of Suction cup in CNC router machine?

Q.16 Write the difference between Stationary machine and CNC machine?

Q.17 What is the CNC machine software program?

Q.18 Describe any four unit of Edge band machine?



BHARTIYA SKILL DEVELOPMENT UNIVERSITY

Answer key

Set –B

School of Woodworking Skills
Session: 2021-22 (Summer Semester)
B. Voc. Program, 3rd Semester,
End-Sem. Examination

Course Code: SCS1305

Time: 2 Hours

Course Name: Wood working CNC Machine

Max. Marks: 50

Instruction:

- All questions from section A, each question carries one marks.
- All questions from section B, each question carries four marks.
- All questions from section C, each question carries six marks.

Section – A

10X01 = 10 Marks

Q.1 Glue application unit applies glue to which of the following in Edge banding machine?

- (a) Both work piece and edge banding tape (b) Work piece
(c) Edge banding tape (d) All of them (b)

Q.2 What is the compressed air pressure consumption in the tempora F600?

- (a) 8-9 bar (b) 5-6 bar
(c) 4-5 bar (d) None of these (d)

Q.3 Which one of the following is the diameter of the grooving saw in Profit H 300 CNC router?

- (a) Ø125 mm (b) Ø175 mm
(c) Ø150 mm (d) None of these (a)

Q.4 How many axis have in CNC router Profit H300?

- (a) 2 (b) 6
(c) 5 (d) None of these (d)

Q.5 CNC router Profit H300 have a Drill head for drilling and sawing is true or false?

- (a) True (b) False (a)

Q.6 How many work stations have in CNC router Profit H300?

- (a) 4 (b) 2
(c) 3 (d) None of these (a)

Q.7 Left to Right is the cutting direction of vertical panel saw is true or false?

- (a) False (b) True (b)

Q.8 Which one of the following material cut on vertical panel saw?

- (a) MDF (b) HDF
(c) Both A&B (d) None of these (c)



BHARTIYA SKILL DEVELOPMENT UNIVERSITY

Q.9 Which one of the following is a property of the End Trimming Unit in Edge banding machine?

- (a) Trim the edge (b) Cut the length
(c) Clean extra material (d) None of these (d)

Q.10 Which type of glue used in the Edge banding machine?

- (a) Water based glue (b) PUR
(c) Hot melt glue (d) Contact glue (c)

Section – B

04X04 = 16 Marks

Q.11 What is the Vertical Saw machine?

Ans. A vertical panel saw requires less floor space and hence is a preferred choice for many. The two rivals of panel saw are table saw and track saw. Having a vertical wall saw that can handle large sheet sizes allows them to operate a smaller capacity table saw, again saving valuable workshop space. It is not just wood based panels that can be cut. Increasingly plastics, composites and non-ferrous.

Q.12 what is the edge banding? & write the type and size of edge band.

Ans. The machine that applies the edge banding is called edge bander. An edge bander bonds the edge banding to the substrate, trims the leading and trailing edges, trims top and bottom flush with the substrate, scraps any surplus, and buffs the finished edge.

Type of edge band is PVC, wooden, veneer,

1. 0.3mm
2. 0.5mm
3. 0.8mm
4. 0.1mm
5. 2mm
6. 3mm

Width of edge is coming in different size 18mm,22mm,24mm,30mm

Q.13 What does the term CNC stands for?

Ans. CNC means **Computer Numerical Control**. This means a computer convert the design produced by Computer Aided Design software (CAD), into numbers. The numbers can be considered to be the coordinates of a graph and they control the movement of the cutter. In this way the computer controls the cutting and shaping of the material.

Q.14 How many faces we have in CNC router machine for machining, make a diagram and indicate the faces?

Ans. CNC router have 5 faces for machining and for all operations. The face 2 is not working because of this face is come in bottom side and this face use for clam the work piece.

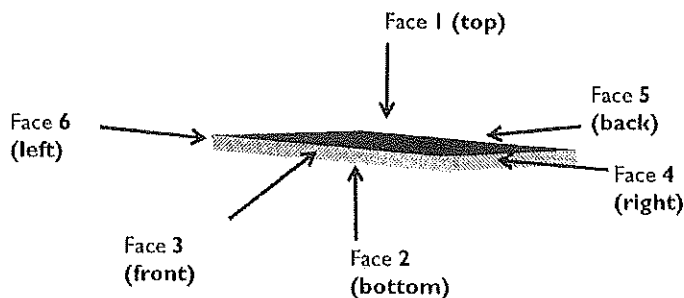

Section – C

04X06 = 24 Marks

Q.15 What is the work of Suction cup in CNC router machine?



BHARTIYA SKILL DEVELOPMENT UNIVERSITY

Ans. Working of the suction cup is to clamp the work piece tightly. It ensures that the suction cups are placed on the suction holes of the vacuum pump to get proper suction, vacuum pump is connected with the suction holes with pipes to provide 6-7 bar suction pressure. It is compulsory to switch ON the vacuum pump before working on the CNC router for clamping of the work piece. The vacuum of the suction cups for the clamping purpose can only be created on a plan and smooth surface.

Q.16 Write the difference between Stationary machine and CNC machine?

Ans.

Stationary machines	CNC machines
Manually working machines	It works automatically.
Manually tool changing.	Automatically tool changer.
Time consuming	Time saving
Require more man power	Require less man power.
No requirement of software for operation.	It require software for operation.
Low cost	High cost
Require less skill.	Require more skill.
It consumes less space.	It consumes more space.

Q.17 What is the CNC machine software program?

Ans. The program is divided into different categories, machine operation, work piece programming and simulation.

Program	Categories	Under Program
Software Wood Flash	Control	CNC Board Tecno Manager
	Programming	Program Editor
	Simulation	2DSimulator SimulationBoard

Q.18 Describe any four unit of Edge band machine?

Ans.

1. Premiling unit
When we put any piece of wood the primilling unit is did the 2mm pri cut on edge of piece
2. Pressure unit
The pressing unit is adjusted by inserting and edge piece and by adjusting the pressure of the large pressure roller to the edge material to be processed.
3. End trimming unit
It is control the cutting angle of edge band
4. Corner rounding unit
Adjust to edge material with m-motion system



BHARTIYA SKILL DEVELOPMENT UNIVERSITY



BHARTIYA SKILL DEVELOPMENT UNIVERSITY

Registration No.:

Set – A

School of Woodworking Skills
Session: 2021-22 (Summer Semester)
B. Voc. 3rd Semester,
End-Sem. Examination

Course Code: SCS1307

Time: 2 Hours

Course Name: Advance Carpenter Materials (SET A)

Max. Marks: 50

Instruction: (if any)

Section – A

10X01 = 10 Marks

Q1. Which part of the trunk is known as growth tissue (forms new cells through cell division)?

- (a) Core
(b) Sapwood
(c) Cambium
(d) Bast

Q2. Where is Sapwood located in the structure of softwood stem?

- (a) Between cambium and core
(b) Between bast and bark
(c) Between pith and core
(d) Between cambium and bast

Q3. Which process is not used for changing the wood colour?

- (a) Bleaching
(b) Pickling
(c) Patinate
(d) Equilize

Q4. Tensile strength is

- (a) Strength of fiber
(b) total deformation
(c) Hardness of wood
(d) None

Q5. The property of material that resist the loads applied to it without failure

- a) Strength
(b) Hardness
(c) Resilience
(d) None

Q6. Veneers that are visible on the finished work-piece are known as

- (a) Blind veneer
(b) Covering veneer
(c) Deck veneer
(d) Barrier veneer

Q7. The property of material that absorb the energy by shocks is

- a) Strength
(b) Hardness
(c) Resilience
(d) None

Q8. Highest hardness wood is

- (a) Teak
(b) Pine
(c) Acacia
(d) Maple

Q9. In HGF laminate, F stands for

- (a) Pressurized
(b) Post formed
(c) Preprocessed
(d) Fire retardent

Q10. The colour of cellulose fibres is?

- (a) White
(b) Black
(c) Gray
(d) Brown

Handwritten signature



BHARTIYA SKILL DEVELOPMENT UNIVERSITY

Section – B

04X04 = 16 Marks

- Q11) What are the functions of sapwood, cambium, bast, and medullary rays with respect to Tress structure.
- Q12) Compare absolute and relative humidity.
- Q13) Explain the heat treatment with its effect on strength of wood.
- Q14) Why wood is considered as sustainable material.

Section – C

04X06 = 24 Marks

- Q15) Explain the mechanical properties of wood.
- Q16) Describe the role of cell structure in influencing the mechanical and physical properties of wood.
- Q 17) Explain different categories of wood preservative.
- Q18) Explain the application process of preservative.



BHARTIYA SKILL DEVELOPMENT UNIVERSITY

Answer key...

Set – A

School of Woodworking Skills
Session: 2021-22 (Summer Semester)
B. Voc. 3rd Semester,
End-Sem. Examination

Course Code: SCS1307

Time: 2 Hours

Course Name: Advance Carpenter Materials (SET A)

Max. Marks:

50

Instruction: (if any)

Section – A

10X01 = 10 Marks

Q1. Which part of the trunk is known as growth tissue (forms new cells through cell division)?

- (a) Core
(b) Sapwood
(c) **Cambium**
(d) Bast

Q2. Where is Sapwood located in the structure of softwood stem?

- (a) **Between cambium and core**
(b) Between bast and bark
(c) Between pith and core
(d) Between cambium and bast

Q3. Which process is not used for changing the wood colour?

- (a) Bleaching
(b) Pickling
(c) Patinate
(d) **Equilize**

Q4. Tensile strength is

- (a) **Strength of fiber**
(b) total deformation
(c) Hardness of wood
(d) None

Q5. The property of material that resist the loads applied to it without failure

- a) **Strength**
(b) Hardness
(c) Resilience
(d) None

Q6. Veneers that are visible on the finished work-piece are known as

- (a) Blind veneer
(b) **Covering veneer**
(c) Deck veneer
(d) Barrier veneer

Q7. The property of material that absorb the energy by shocks is

- a) Strength
(b) Hardness
(c) **Resilience**
(d) None

Q8. Highest hardness wood is

- (a) **Teak**
(b) Pine
(c) Acacia
(d) Maple

Q9. In HGF laminate, F stands for

- (a) Pressurized
(b) Post formed
(c) Preprocessed
(d) **Fire retardent**

Q10. The colour of cellulose fibres is?

- (a) White
(b) Black
(c) **Gray**
(d) Brown



BHARTIYA SKILL DEVELOPMENT UNIVERSITY

Section – B

04X04 = 16 Marks

Q11) What are the functions of sapwood, cambium, bast, and medullary rays with respect to Tress structure.

Answer:

The sapwood (sapwood) has the task of transporting water and nutrients from the roots to the leaves. Sapwood is less durable than heartwood. Sapwood can be lighter in color than the heartwood. This varies depending on the type of wood.

The cambium is the growth layer of the tree. It is a thin, sensitive layer. The cambium is responsible for the production of new wood during the growing season of the tree (spring and summer).

The bast is under the bark. It transports the nutrients produced in the leaves into the tree trunk.

The bark is the outermost layer of the tree. Their function is to protect the tree against extreme temperatures, pests and diseases. The bark is called bark together with the bast.

The medullary rays are not a trunk layer. They connect the center of the trunk with the various base layers for water and nutrient transport.

Q12) Compare absolute and relative humidity.

Answer:

Absolute humidity: It is the mass of water vapour present in 1 m³ of dry air, and is generally expressed in terms of gram per cubic metre of dry air (g /m³ of dry air). It is also expressed in terms of grains per cubic metre of dry air. Mathematically, one kg of water vapour is equal to 15 430 grains.

Relative humidity: It is the ratio of actual mass of water vapour in a given volume of moist air to the mass of water vapour in the same volume of saturated air at the same temperature and pressure. It is briefly written as RH(ϕ).

Q13) Explain the heat treatment with its effect on strength of wood.

Answer:

Because treated wood is intended to extend the usefulness and life of wood, fewer trees are required to perform the same function that is required when untreated wood is used.

Wood that has been appropriately treated can significantly reduce the number of trees that would otherwise need to be harvested.

If untreated wood only lasts 5 years and treated wood lasts 25 years or more, it would take at least 5 times as many trees over the same period of time, as well as the incremental labor, to continually harvest, manufacture, replace and dispose of all of the untreated wood.

Unprotected wood can begin to rot within 1-2 years depending on the environment.

The structural integrity of untreated wood can be greatly reduced within weeks due to termites and certain marine organisms.

Without chemical treatments, wood can be quickly consumed when exposed to flames.

Q14) Why wood is considered as sustainable material.

Answer:

It's a renewable material

It lasts a long time



BHARTIYA SKILL DEVELOPMENT UNIVERSITY

It can be recycled and reused

It absorbs carbon dioxide

It's great at retaining heat

Its waste is 100 per cent biodegradable

It has a positive effect on your physical and mental health

Section – C

04X06 = 24 Marks

Q15) Explain the mechanical properties of wood.

Answer:

1. **STIFFNESS:** The property by means of which a body acted upon by external forces tends to retain its natural size and shape, or resists deformation. □ Thus a material that is difficult to bend or otherwise deform is stiff; one that is easily bent or otherwise deformed is flexible. Flexibility is not the exact counterpart of stiffness, as it also involves toughness and pliability.
2. **Strength:** The property of material by virtue of it can sustain the load or forces without failure.
3. **TENSILE STRENGTH :**The tensile strength of wood parallel to the grain depends upon the strength of the fibers and is affected not only by the nature and dimensions of the wood elements but also by their arrangement.
4. **COMPRESSIVE OR CRUSHING STRENGTH :**Is very closely related to hardness and transverse shear. □ There are two ways in which wood is subjected to stress of this kind, namely, (1) with the load acting over the entire area of the specimen, and (2) with a load concentrated over a portion of the area.
5. **SHEARING STRENGTH :** Whenever forces act upon a body in such a way that one portion tends to slide upon another adjacent to it the action is called a shear. In wood this shearing action may be (1) along the grain, or (2) across the grain.
6. **TRANSVERSE OR BENDING STRENGTH: BEAMS:** When external forces acting in the same plane are applied at right angles to the axis of a bar so as to cause it to bend, they occasion a shortening of the longitudinal fibers on the concave side and an elongation of those on the convex side

Q16) Describe the role of cell structure in influencing the mechanical and physical properties of wood.

Solution:

The microscopic structure of wood cross section is tubular. The cells each consist of cell walls and cell cavities and their arrangement can be compared with a bunch of drinking straws. The size and arrangement of the wooden cells vary depending on the type of wood.

The hardness and strength of a type of wood largely depend on how big the wooden cells are and how the wooden cells are arranged next to each other. The wooden cells that form in spring are large, the wood mass is loose and porous, and the cell walls are thin. This is the so-called early wood. In contrast, the late wood, which forms in summer and autumn, consists of much smaller, but thicker-walled cells.

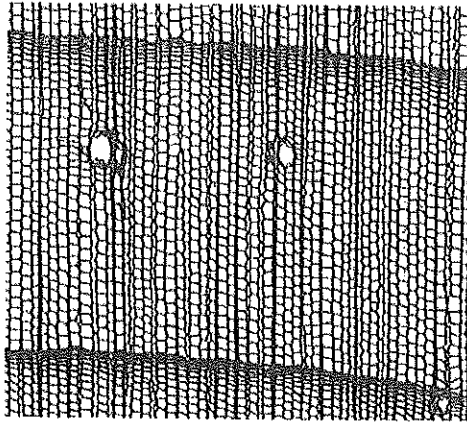

Softwood enlarged 70 times

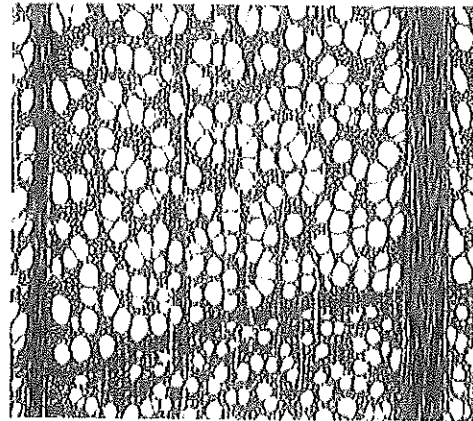

Hardwood enlarged 70 times

Q 17) Explain different categories of wood preservative.

Solution:

Oil-borne Preservatives

These chemicals are generally insoluble in water so they are usually dissolved in petroleum or other organic solvents in order to penetrate wood

Water-borne Preservatives

This class includes various metallic salts and other compounds. The principal compounds used are combinations of copper, chromium, arsenic and fluoride. Water-borne preservatives are experiencing increasingly wider use for lumber, plywood, fence posts, poles, pilings and timbers.

Fumigants

Fumigants are used to control an existing internal decay or insect attack or to prevent future problems. The fumigant, methylisothiocyanate (mitc), is available in products that contain one of three active ingredients - methylisothiocyanate (mitc), dazomet, or metam-sodium.

Q18) Explain the application process of preservative.

Solution:

The numerous nonpressure processes differ widely in the penetration and retention levels of preservative attained, and consequently in the degree of protection they provide to the treated wood.

When similar retention and penetration levels are achieved, wood treated by a nonpressure method should have a service life comparable to that of wood treated by pressure.

Nevertheless, results of nonpressure treatments, particularly those involving surface applications, are not generally as satisfactory as those of pressure treatment.

The superficial processes do serve a useful purpose when more thorough treatments are impractical or exposure conditions are such that little preservative protection is required.



BHARTIYA SKILL DEVELOPMENT UNIVERSITY

Registration No.:

School of Woodworking Skills
Session: 2021-22 (Summer Semester)
B. Voc. Program, 3rd Semester,
End-Sem. Examination

Course Code: SCS1307

Time: 2 Hours

Course Name: Advanced Carpenter Materials (SET B)

Max. Marks: 50

Instruction: All the questions are compulsory.

Section – A

10X01 = 10 Marks

- Q1) In which direction the maximum wood shrinkage takes place?**
- (a) Tangential (b) Radial
(c) Cross-sectional (d) Equal in all directions
- Q2) Which component of the wood acts as a binding material?**
- (a) Cellulose (b) Lignin
(c) Resins (d) Starches
- Q3) When material absorb the energy of force or load imposed on it, characteristic is called**
- (a) Impact (b) Hardness
(c) Resilience (d) None
- Q4) The layer responsible for transport of nutrient to the core called as**
- (a) Core (b) Sapwood
(c) Cambium (d) Medullary rays
- Q5) Name the wood having Brinell hardness number equal to 48 N/mm²**
- (a) Acacia (b) Oak
(c) Teak (d) Plum tree
- Q6) The most suitable wood for Fire resistance behavior**
- (a) Acacia (b) Oak
(c) Teak (d) Plum tree
- Q7) One of the essential properties of abrasive for its selection is**
- (a) Plasticity (b) Density
(c) Particle size (d) Humidity
- Q8) How should be the colour of good quality timber?**
- (a) Light (b) Gradient
(c) Brown (d) Dark
- Q9) Which is not a type of wood seasoning?**
- (a) Air Seasoning (b) Water Seasoning
(c) Fire Seasoning (d) Kiln Seasoning
- Q10) In HGP laminate, P stands for**
- (a) Pressurized (b) Post formed
(c) Preprocessed (d) Penetrated

Handwritten signature



BHARTIYA SKILL DEVELOPMENT UNIVERSITY

Section – B

04X04 = 16 Marks

- Q11) Define following for wood: a) Wood colour b) Wood insulation behavior
- Q12) Define the terms a) shrinkage and swelling b) Relative humidity.
- Q13) Define following a) Strength and its types b) Resilience
- Q14) Define Heat treatment of wood and its importance.

Section – C

04X06 = 24 Marks

- Q15) Describe the need of preservative for wood.
- Q16) Explain the thermal properties of wood.
- Q17) What is sustainability in wood? Which wood is most sustainable?
- Q18) Explain the importance of drying or seasoning for wood product.



BHARTIYA SKILL DEVELOPMENT UNIVERSITY

Answer key....

School of Woodworking Skills
Session: 2021-22 (Summer Semester)
B. Voc. Program, 3rd Semester,
End-Sem. Examination

Course Code: SCS1307

Time: 2 Hours

Course Name: Advanced Carpenter Materials (SET B)

Max. Marks: 50

Instruction: All the questions are compulsory.

Section – A

10X01 = 10 Marks

Q1) In which direction the maximum wood shrinkage takes place?

- (a) Tangential (b) Radial
(c) Cross-sectional (d) Equal in all directions

Q2) Which component of the wood acts as a binding material?

- (a) Cellulose (b) Lignin
(c) Resins (d) Starches

Q3) When material absorb the energy of force or load imposed on it, characteristic is called

- (a) Impact (b) Hardness
(c) Resilience (d) None

Q4) The layer responsible for transport of nutrient to the core called as

- (a) Core (b) Sapwood
(c) Cambium (d) Medullary rays

Q5) Name the wood having Brinell hardness number equal to 48 N/mm²

- (a) Acacia (b) Oak
(c) Teak (d) Plum tree

Q6) The most suitable wood for Fire resistance behavior

- (a) Acacia (b) Oak
(c) Teak (d) Plum tree

Q7) One of the essential properties of abrasive for its selection is

- (a) Plasticity (b) Density
(c) Particle size (d) Humidity

Q8) How should be the colour of good quality timber?

- (a) Light (b) Gradient
(c) Brown (d) Dark

Q9) Which is not a type of wood seasoning?

- (a) Air Seasoning (b) Water Seasoning
(c) Fire Seasoning (d) Kiln Seasoning

Q10) In HGP laminate, P stands for

- (a) Pressurized (b) Post formed
(c) Preprocessed (d) Penetrated



BHARTIYA SKILL DEVELOPMENT UNIVERSITY

Section – B

04X04 = 16 Marks

Q11. Define following for wood: a) Wood colour b) Wood insulation behavior

Answer:

Depending on the type of wood, wood has a different color. The color can also differ greatly within the same type of wood. These color differences are natural and strongly depend on the origin and location of the tree. Nevertheless, the wood color is an important feature in the detection of wood types. Certain types of wood are two-tone. Their heartwood is a darker color than their sapwood. Such types of wood have a colored core and are called "heartwoods."

The wood color can be changed artificially. Wood can be bleached, colored (stained), glazed, oiled, varnished, leached, steamed, smoked or thermally treated. When wood is painted or oiled, its color usually becomes more intense and darker. The color of the wood changes over time due to the influence of daylight (light wood becomes darker, dark wood becomes lighter)

The color of the wood changes over time due to the effects of weather (wood turns gray).

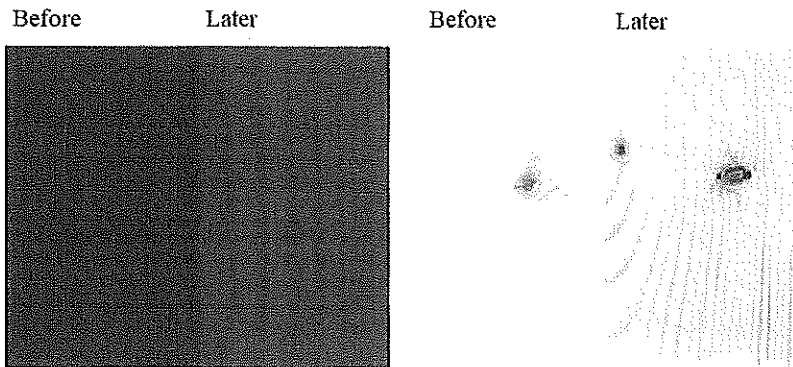

b) Compared to other materials, wood is considered moderately combustible. The water contained in the wood has a cooling effect on the fire and thus influences the fire behavior. Not every type of wood burns equally well. Basically, light types of wood burn faster than heavy ones. Not only the weight is decisive for the fire behavior, but also the ingredients of the wood.

Tests have shown that of the European types of wood, oak burns slowly and is therefore the most suitable for fire protection products.

Q12. Define the terms a) shrinkage and swelling b) Relative humidity.

Solution:

When wood is dried, it releases moisture and begins to shrink. This process is called "shrinkage". If wood absorbs moisture, it gets bigger. This process is called "swelling". Since the humidity changes again and again depending on the weather and the season, the wood moisture also changes again and again. This means that the wood changes its size again and again; sometimes it decreases, sometimes it increases.

Common observation for this process very well with wooden floors:

- In summer, when the air humidity is high, wooden floors have closed joints.
- In winter, when the air humidity is low, wooden floors often have open joints.
- This process is never completed and is repeated every year



BHARTIYA SKILL DEVELOPMENT UNIVERSITY

b) Relative humidity: It is the ratio of actual mass of water vapour in a given volume of moist air to the mass of water vapour in the same volume of saturated air at the same temperature and pressure. It is briefly written as $RH(\phi)$.

Q13. Define following a) Strength and its types b) Resilience

Answer:

Strength: The property of material by virtue of it can sustain the load or forces without failure.

3. TENSILE STRENGTH :The tensile strength of wood parallel to the grain depends upon the strength of the fibers and is affected not only by the nature and dimensions of the wood elements but also by their arrangement.

4. COMPRESSIVE OR CRUSHING STRENGTH :Is very closely related to hardness and transverse shear. □
There are two ways in which wood is subjected to stress of this kind, namely, (1) with the load acting over the entire area of the specimen, and (2) with a load concentrated over a portion of the area.

5. SHEARING STRENGTH : Whenever forces act upon a body in such a way that one portion tends to slide upon another adjacent to it the action is called a shear. In wood this shearing action may be (1) along the grain, or (2) across the grain.

6. TRANSVERSE OR BENDING STRENGTH: BEAMS: When external forces acting in the same plane are applied at right angles to the axis of a bar so as to cause it to bend, they occasion a shortening of the longitudinal fibers on the concave side and an elongation of those on the convex side

b) RESILIENCE: Is the amount of work done upon a body in deforming it. Within the elastic limit it is also a measure of the potential energy stored in the material and represents the amount of work the material would do upon being released from a state of stress.

Q14. Define Heat treatment of wood and its importance.

Answer:

Heat treatment is one of the wood modification methods for improving wood properties such as dimensional stability, water resistance, and biological durability without using harmful chemicals. In recent years, wood products with increased performance and without toxic preservatives are increasingly demanded by customers, thus contributing to the popularity of heat-treated wood. Heat-treated wood is increasingly used in many applications such as hardwood flooring, siding/cladding, decking, saunas/wall panelling, windows/doors, and garden furniture. Heat treatment or thermal modification is controlled pyrolysis of wood being treated at high temperatures between 180°C and 240°C under an oxygen-free atmosphere to avoid burning, involving either steam, nitrogen, or oil. Important process variables are temperature and atmosphere. Different processes give different heat-induced chemical changes in wood.

Section – C

04X06 = 24 Marks



BHARTIYA SKILL DEVELOPMENT UNIVERSITY

Q15. Describe the need of preservative for wood.

Answer:

The use of chemicals to prevent or retard the decay of wood, especially by fungi or insects; widely used preservatives include creosote, pitch, sodium fluoride and tar; especially used on wood having contact with the ground. Wood products can be protected from the attack of decay fungi, harmful insects, or marine borers by applying chemical preservatives. Preservative treatments greatly increase the life of wood structures, thus reducing replacement costs and allowing more efficient use of forest resources. The degree of protection achieved depends on the preservative used and the proper penetration and retention of the chemicals. Some preservatives are more effective than others, and some are more adaptable to certain use requirements. To obtain long-term effectiveness, adequate penetration and retention are needed for each wood species, chemical preservative, and treatment method. Wood preservation involves the pressure or thermal impregnation of chemicals into wood. The process results in long-term resistance to attack by fungi, bacteria, insects, and marine borers. Wood preservatives work by being toxic to the biological organisms that attack wood. The active ingredients in wood preservative formulations are many and varied and each has its own mode of action, some of which are still unknown or unreported.

Q16. Explain the thermal properties of wood.

Answer:

1. **Thermal conductivity** represents the wood property to conduct heat. Thermal conductivity is property by which we are able to distinguish wood as heat insulator or pure heat conductor. Wood exhibits a low thermal conductivity (high heat-insulating capacity) compared with materials such as metals, marble, glass, and concrete. Thermal conductivity is highest in the axial direction and increases with density and moisture content; thus, light, dry woods are better insulators.
2. **Thermal diffusivity:** Thermal diffusivity is a measure of how quickly a material can absorb heat from its surroundings. It is defined as the ratio of thermal conductivity to the product of density and heat capacity. Therefore, conclusions regarding its variation with temperature and density are often based on calculating the effect of these variables on heat capacity and thermal conductivity. Because of the low thermal conductivity and moderate density and heat capacity of wood, the thermal diffusivity of wood is much lower than that of other structural materials, such as metal, brick, and stone.
3. **Specific heat of wood/Heat capacity :** Specific heat capacity is defined as the amount of heat that a kilogram of a given substance is required to absorb in order to increase its temperature by one degree. The heat capacity of wood depends on the temperature and moisture content of the wood but is practically independent of density or species.
4. **Coefficient of Thermal Expansion :** The coefficient of thermal expansion is a measure of the relative change of dimension caused by temperature change. The thermal expansion coefficients of completely dry wood are positive in all directions; that is, wood expands on heating and contracts on cooling.

Q17) What is sustainability in wood? Which wood is most sustainable?

Answer;

It's a renewable material

It lasts a long time

It can be recycled and reused

It absorbs carbon dioxide

It's great at retaining heat



BHARTIYA SKILL DEVELOPMENT UNIVERSITY

Waste is 100 per cent biodegradable

It has a positive effect on your physical and mental health

Timber is usually classified as either hardwood, from broad leafed trees, such as Beech and Oak, or softwood from conifers like Pine and Fir. Simply because they're replaceable, fast-growing species like Pine trees tend to be more sustainable than slow-growing trees like Oak. Oak forests have to be managed carefully to make them sustainable, grown and harvested in the right way, but it can be done."

Q18. Explain the importance of drying or seasoning for wood product.

Answer:

The process of inducing evaporation of the moisture contained in wood; a type of hydrothermal treatment of wood is known as wood seasoning. The purpose of seasoning is to reduce the moisture content in the wood to a level appropriate to the use of the articles made from the wood. This prevents changes in the dimensions and shape of the articles, eliminates wood rot, increases the strength of the wood, reduces the weight of the articles, strengthens glued joints, and improves the quality of finishing. Wood is seasoned in various forms: lumber, peeled or planed veneers, crushed wood particles, and semi-finished articles.

Natural drying

wooden boards in an airy place protected from the weather. The individual boards should be stacked on top of one another at regular intervals using spacer strips. This allows the air to circulate around the boards, extract moisture from the wood and dry it.

Artificial drying

Since outdoor drying takes a few months and the wooden boards cannot be dried enough to be used for interior work, wood is usually artificially dried. Artificial drying takes place in a drying oven and is therefore also called oven drying.

The wooden boards are pushed into the drying oven. Then the oven is closed and heated. The warm, dry air is blown around and through the wooden boards with a fan, where it absorbs the moisture from the wooden boards and thus dries the wooden boards

