

Q.8 _____ is the opposite of the word- **Aggressive**:

- a) Boring
b) Courageous
c) Jovial
d) Easygoing

Q.9. Choose the correct answer for the indirect speech of the given sentence:

Teacher said, "Shimla is a hill station."

- a) Teacher said that Shimla is a hill station.
b) Teacher said that Shimla was a hill station.
c) Teacher says that Shimla has been a hill station.
d) Teacher said that Shimla had been a hill station.

Q.10 In the story –*The Snake in the Grass*, whom does the beggar send to the bungalow to catch the snake?

- a) Gardener
b) Snake- charmer
c) Coolie
d) Police officer

2. Section B

04×04 = 16

Q11. What is the message given by the poet in the **poem Virtue**?

Q12. Which character of the story does the phrase *A Snake in the Grass* signify and why?

Q13. Construct sentences using each of the following modal verbs (one sentence with each Modal verb).
Dare, might, would, ought

Q14. Explain the lines with reference to the context: "*You are fortunate. It is God Subramanya who has come to visit you. Dont kill the snake*".

3. Section C

04×06 = 24

Q.15. Write a short summary of the story- *A Snake in the grass*.

Q16. Describe your best friend using any ten appropriate describing words and underline the describing words.

Q17. Write a paragraph of about 150 words on the given topic- *The Aim of My Life*.

Q18. Read the passage carefully and make a precis of the same.

Dry fruits are useful in various diseases of the brain, muscles and tissues. Almonds have unique properties to remove brain weakness and strengthen it. Almond preserves the vitality of the brain, strengthen the muscles and destroy diseases originating from nervous and bilious disorders. Walnut is another dry fruit that possesses wonderful qualities of curing brain weakness. According to Dr. Johnson, almonds, figs, grapes, dates, apples, and oranges are rich in phosphoric elements and should normally be used by brain workers. Phosphorus nourishes the vital tissues of the body. It keeps the mind full of enthusiasm for more work. (98 words)

Answer the following questions:

A. Dry fruits are useful because they: (1)

- a. Strengthen our heart
- b. Cure various diseases of the brain, muscles and tissues
- c. Give confidence to us
- d. Empower us to do challenging tasks.

B. Which one is not a property of almonds? (1)

- a. It preserves the vitality of the brain
- b. It strengthens the muscles
- c. It destroys diseases originating from nervous and bilious disorders
- d. It strengthens our digestive system.

C. Phosphoric element is profusely found in (1)

- a. Almonds, figs, grapes, dates, apples and oranges
- b. Almonds, figs, papayas, guavas and pineapples
- c. All the green vegetables
- d. Seasonal fruits.

D- Write a Precis of the given passage. (3)

THEORY END-SEM EXAMINATION			
SESSION: 2022-23(WINTER SEMESTER)			
B.Voc	Semester	3 rd	
Course Name / Module	Spoken English		
Course Code	Gen1301		
Date			
Name of the Student		Reg. No.	

INSTRUCTION:

• ANSWER KEYS SET B

1. Section A (10 objective type questions, each question carries 01 mark)

10×1 = 10

Q1. Which of the following words has a sound of the diphthong- /eə/ ?

- a) Brick
- b) Bag
- c) Bake
- d) Bear**

Q2.Fill in the blank with the correct modal auxiliaries given below:

You have travelled a long way. you ____ be feeling tired.

- (a) Might
- (b) Must**
- (c) May
- (d) Will

Q3. Choose the correct answer of the passive voice of the given sentence

My mother cooks food.

- (a) Food is cooked by my mother.**
- (b) Food was cooked by my mother.
- (c) Food was cooked by my mother.
- (d) Food was being cooked by my mother.

Q4. _____ is the writer of the poem *Virtue*

- (a) W. H. Davis
- (b) George Herbert**
- (c) R.K. Narayan
- (d) Robert Frost

Q5.Fill in the blank with the correct modal verb:

I used to play cricket every evening during my college days

- (a) Used to**
- (b) Ought
- (c) Need
- (d) Must

Q.6 Select the correct question tag for the given sentence.

She is very hardworking, _____?

BHARTIYA SKILL DEVELOPMENT UNIVERSITY JAIPUR

Plot No. 005/001-002 | Domestic Tariff Area | Mahindra World City | Jaipur | Rajasthan

www.fuj-bsdu.in | +91 91166 11131

Lib0395

- (a) doesn't it?
- (b) Isn't she?**
- (c) Don't they
- (d) Wasn't it?

Q.7 Complete the lines with the right word as given in the poem:

Thy _____ is ever in its grave ,

- (a) stem
- (b) leaves
- (c) root**
- (d) fruit

Q.8 _____ is the opposite of the word- **Aggressive**:

- a) Boring
- b) Courageous
- c) Jovial
- d) **Easygoing**

Q.9. Choose the correct answer for the indirect speech of the given sentence:

Teacher said, "Shimla is a hill station."

- (a) **Teacher said that Shimla is a hill station.**
- (b) Teacher said that Shimla was a hill station.
- (c) Teacher says that Shimla has been a hill station.
- (d) Teacher said that Shimla had been a hill station.

Q.10 In the story – *The Snake in the Grass*, whom does the beggar send to the bungalow to catch the snake?

- (a) Gardener
- (b) **Snake- charmer**
- (c) Coolie
- (d) Police officer

2. Section B (04 short answer type questions, each question carries 04 marks)

04×04 = 16

Q11. Write the message given by the poet in the **poem Virtue**.

The poem promotes building virtues in ones personality to attain immortality in this mortal world . Through examples the poet highlights the value and existence of virtuous souls in this world even after their death. He advocated developing values in order to be permanently present in this mortal world.

Q12. Which character of the story is signified as *A Snake in the Grass* and why?

The title signifies towards Dasa being unfaithful towards his work. Since the beginning , he is seen being very casual even in crisis situation such as even at the presence of a cobra in the compound of the bungalow. He makes excuses to justify his laziness thus leaving the garden unmaintained. Finally, overtly, he tries to cheat the family by telling them of trapping the snake in the pot whilst, it was spotted later in the hole of the compound wall . The writer uses the phrase as a pun to signal Dasa being the real Snake in the Grass.

Q13. Construct sentences using each of the following modal verbs (one sentence with each Modal verb).

Dare, might, would, ought

Q14. Explain the lines with reference to the context: "*You are fortunate. It is God Subramanya who has come to visit you. Dont kill the snake*".

These lines are from the short story – *Snake in the Grass* written by R. K. Narayan. The above lines are spoken by a beggar who asks alms from the inmates of a bungalow engaged in snake hunt as a

cobra had entered the bungalow. The beggar on knowing the situation shows her religious sentiments and forbids the family from killing the snake referring it to be an incarnation of god subramanya

3. Section C (04 long type questions, each question carries 06 marks)	04×06 = 24
--	-------------------

Q.15. Write a short summary of the story- *A Snake in the grass*.

Summary

“A Snake in the grass” is a story written by R.K. Narayan. One day a cyclist told a family living in a big house that a snake had entered their garden. Everyone in the family was very frightened. They were angry with their old servant, Dasa. They told him that he had not cleaned the garden. They searched the garden but could not find the snake. One beggar woman came and said that the snake was a blessing from God. Then, a snake charmer came, but he said that he could not see any snake. At that moment, Dasa came with a pot and said that he had caught the snake and put it in the pot. Everyone was happy. Suddenly they saw a snake come out of a hole in the wall. They were all shocked. They did not know if Dasa had caught the snake or if there were two snakes.

Q16. Describe your best friend using any ten appropriate describing words and underline the describing words.

Use describing words such as – Honest, Friendly, helpful, sociable, Jovial, Humorous, introvert, extrovert, soft spoken. Humble etc to detail the qualities of the friend

Q17. Write a paragraph of about 150 words on the given topic- The Aim of my Life

The passage should highlight the aim /aspirations/ ambition, passions, interests of life and detail the efforts to attain them. Also detail the reason for having the particular aim.

Q18. Read the passage carefully and make a precis of the same.

Dry fruits are useful in various diseases of the brain, muscles and tissues. Almonds have unique properties to remove brain weakness and strengthen it. Almond preserves the vitality of the brain, strengthen the muscles and destroy diseases originating from nervous and bilious disorders. Walnut is another dry fruit that possesses wonderful qualities of curing brain weakness. According to Dr. Johnson, almonds, figs, grapes, dates, apples, and oranges are rich in phosphoric elements and should normally be used by brain workers. Phosphorus nourishes the vital tissues of the body. It keeps the mind full of enthusiasm for more work.(98 words)

Answer the following questions:

A. Dry fruits are useful because they: (1)

- (a) Strengthen our heart
- (b) Cure various diseases of the brain, muscles and tissues**
- (c) Give confidence to us
- (d) Empower us to do challenging tasks.

B. Which one is not a property of almonds?(1)

- (a) It preserves the vitality of the brain
- (b) It strengthens the muscles
- (c) It destroys diseases originating from nervous and bilious disorders
- (d) It strengthens our digestive system.**

C. Phosphoric element is profusely found in

- (a) **Almonds, figs, grapes, dates, apples and oranges (1)**
- (b) Almonds, figs, papayas, guavas and pineapples
- (c) All the green vegetables
- (d) Seasonal fruits.

D- Write a Precis of the given passage. (3)

Title: Dry Fruits- Source of Nutrition

Dry fruits adds strength to the brain preserve the vitality, strengthen the muscles and destroy nervous and bilious disorders. Walnuts cure brain weakness while figs, grapes, dates, apples, and oranges nourish the tissues of the body (36 words).



THEORY END-SEM EXAMINATION		
SESSION: 2022-23(WINTER SEMESTER)		
B.Voc/M.Voc	B.Voc.	Semester 3 rd
Course Name / Module	Computer Aided Drawing	
Course Code	GEN 1302	
Date		
Name of the Student		Reg. No.

INSTRUCTION:
<ul style="list-style-type: none">● Maximum Marks: 50● Duration of Examination: 2 Hours● Attempt all questions.
SET - A

1. Section A	10×1 = 10
---------------------	------------------

1. Which type of line is used to represent the visible edges of an object in an engineering drawing?
 - a) Center line
 - b) Hidden line
 - c) Continuous thick line
 - d) Object line

2. Which type of line is used to indicate the cutting plane in a sectional view?
 - a) Hidden line
 - b) Section line
 - c) Center line
 - d) Object line

3. What is the purpose of an isometric drawing?
 - a) To show the true shape and size of objects
 - b) To show the internal details of objects
 - c) To provide a realistic 3D representation of objects
 - d) To provide a top-down view of objects

4. Which type of projection shows the object as it appears to the eye from one viewpoint?
 - a) Orthographic projection
 - b) Perspective projection
 - c) Isometric projection
 - d) Auxiliary projection

5. In a multi-view drawing, which view is typically placed above the front view?
 - a) Top view
 - b) Side view



- c) Isometric view
 - d) Bottom view
6. What is the purpose of a dimension line in an engineering drawing?
- a) To indicate the material used in the object
 - b) To show the location of hidden features
 - c) To provide information about the size of features
 - d) To indicate the direction of movement in an assembly
7. Which of the following is the correct size of A4 sheet of paper?
- a) 220 x 270 mm
 - b) 210 x 297 mm
 - c) 210 x 280.5 mm
 - d) 210 x 270 mm
8. What does the abbreviation "R" stand for in a dimension such as "R10"?
- a) Radius
 - b) Diameter
 - c) Right angle
 - d) Right-hand thread
9. Which type of line is used to indicate the center of a hole in an engineering drawing?
- a) Object line
 - b) Hidden line
 - c) Center line
 - d) Section line
10. Which projection method shows the true size and shape of an object's features?
- a) Orthographic projection
 - b) Perspective projection
 - c) Isometric projection
 - d) Auxiliary projection

2. Section B

04×04 = 16

- 11. Explain projection and views with a proper diagram?
- 12. Define fits with their types.
- 13. Explain unilateral and bilateral tolerance with the help of an example?
- 14. What do you mean by section view?



3. Section C

04×06 = 24

15. What do you mean by the layout of an engineering drawing, explained with the help of a proper diagram?
16. What do you mean by section views also explain the difference between a broken section view and a half-section view with the help of a diagram.
17. Explain any three differences between drawing instruments and accessories.
18. Write down differences between engineering drawing and artistic drawing?

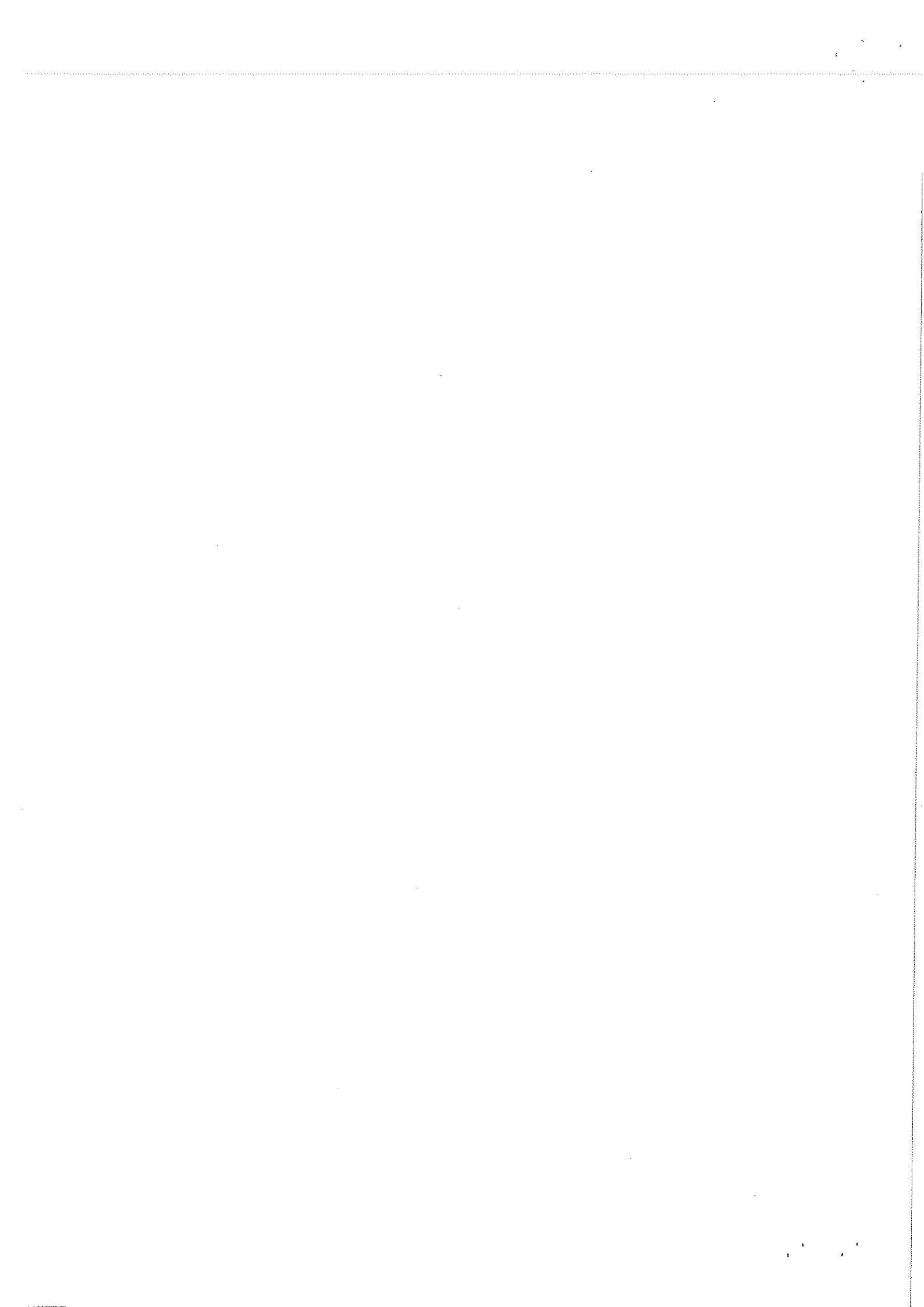



THEORY END-SEM EXAMINATION			
SESSION: 2022-23(WINTER SEMESTER)			
B.Voc/M.Voc	B.Voc.	Semester	3 rd
Course Name / Module	Computer Aided Drawing		
Course Code	GEN 1302		
Date			
Name of the Student		Reg. No.	

INSTRUCTION:
<ul style="list-style-type: none">● Maximum Marks: 50● Duration of Examination: 2 Hours● Attempt all questions.
SET - A Answer Key

1. Section A	10×1 = 10
---------------------	------------------

1. Which type of line is used to represent the visible edges of an object in an engineering drawing?
 - a) Center line
 - b) Hidden line
 - c) Continuous thick line**
 - d) Object line

2. Which type of line is used to indicate the cutting plane in a sectional view?
 - a) Hidden line
 - b) Section line**
 - c) Center line
 - d) Object line

3. What is the purpose of an isometric drawing?
 - a) To show the true shape and size of objects
 - b) To show the internal details of objects
 - c) To provide a realistic 3D representation of objects**
 - d) To provide a top-down view of objects

4. Which type of projection shows the object as it appears to the eye from one viewpoint?
 - a) Orthographic projection
 - b) Perspective projection**
 - c) Isometric projection
 - d) Auxiliary projection

5. In a multi-view drawing, which view is typically placed above the front view?
 - a) Top view
 - b) Side view

- c) Isometric view
d) **Bottom view**
6. What is the purpose of a dimension line in an engineering drawing?
a) To indicate the material used in the object
b) To show the location of hidden features
c) **To provide information about the size of features**
d) To indicate the direction of movement in an assembly
7. Which of the following is the correct size of A4 sheet of paper?
a) 220 x 270 mm
b) **210 x 297 mm**
c) 210 x 280.5 mm
d) 210 x 270 mm
8. What does the abbreviation "R" stand for in a dimension such as "R10"?
a) **Radius**
b) Diameter
c) Right angle
d) Right-hand thread
9. Which type of line is used to indicate the center of a hole in an engineering drawing?
a) Object line
b) Hidden line
c) **Center line**
d) Section line
10. Which projection method shows the true size and shape of an object's features?
a) **Orthographic projection**
b) Perspective projection
c) Isometric projection
d) Auxiliary projection

2. Section B

04×04 = 16

11. Explain projection and views with a proper diagram?

Ans:

The act of obtaining the image of an object is termed "projection".

The image obtained by projection is known as a "view".

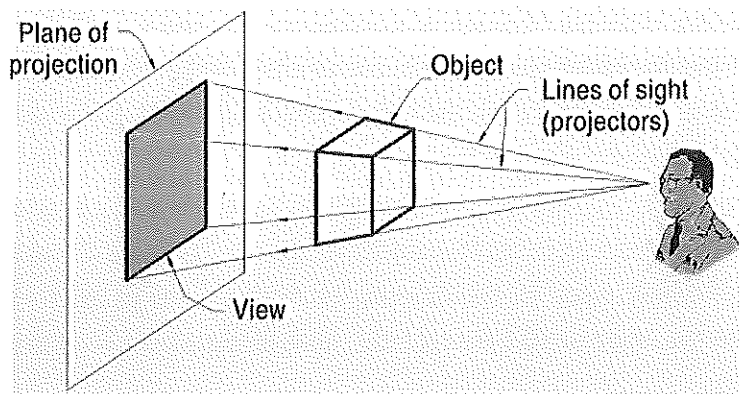

12. Define fits with their types.

Ans:

In mechanical engineering, the term "fits" refers to the dimensional relationship between two mating parts. It defines the amount of clearance or interference between the parts when they are assembled together. Fits are essential to ensure proper functionality, assembly, and interchangeability of components. There are three basic types of fits:

1. **Clearance Fit:** In a clearance fit, there is intentional clearance or space between the mating parts when assembled. The smaller part will have a slightly smaller dimension than the larger part, allowing for easy assembly and disassembly. Clearance fits are commonly used when the parts need to move freely or when ease of assembly and disassembly is a priority.
2. **Interference Fit:** In an interference fit, the mating parts have overlapping dimensions, resulting in an interference or tight fit when assembled. This type of fit requires external force or assembly methods such as heating, cooling, or pressing to fit the parts together. Interference fits are used when a rigid connection is required or when components need to be securely joined together.
3. **Transition Fit:** A transition fit is one where the mating parts have a range of clearance that can result in either a clearance fit or an interference fit, depending on the specific tolerances used. This type of fit provides flexibility in assembly and allows for a range of clearances or interferences based on the specific requirements of the application.

13. Explain unilateral and bilateral tolerance with the help of an example?

Ans:

Unilateral and bilateral tolerances are two concepts used in dimensional engineering to specify the allowable variation or deviation in the dimensions of a part or component. Let's explore each concept with an example:

Unilateral Tolerance:

BHARTIYA SKILL DEVELOPMENT UNIVERSITY JAIPUR

Plot No. 005/001-002 | Domestic Tariff Area | Mahindra World City | Jaipur | Rajasthan

www.ruji-bsdu.in | +91 91166 11131

Unilateral tolerance is when the allowable deviation is specified only on one side of the nominal dimension. This means that the dimension can deviate in one direction, either above or below the nominal value, but not in both directions. It is often used when there is a critical requirement for the dimension to be within a specific range in one direction.

Example: Consider a cylindrical shaft that has a specified diameter of 25 mm with a unilateral tolerance of +0.05 mm. This means the diameter can be slightly larger than the nominal value (25 mm), but it should not be smaller. The allowable range for the diameter would be 25 mm to 25.05 mm. Any diameter measurement within this range would be acceptable, while diameters below 25 mm would be considered out of tolerance.

Bilateral Tolerance:

Bilateral tolerance is when the allowable deviation is specified on both sides of the nominal dimension. This means that the dimension can deviate in either direction, both above and below the nominal value, within the specified tolerance range. Bilateral tolerances are commonly used when there is a need for flexibility in the acceptable range of dimensions.

Example: Let's consider a rectangular plate with a specified length of 100 mm and a bilateral tolerance of ± 0.1 mm. In this case, the allowable range for the length would be 99.9 mm to 100.1 mm. Any length measurement within this range would be acceptable, while lengths below 99.9 mm or above 100.1 mm would be considered out of tolerance.

In both cases, the tolerance values specify the acceptable deviation from the nominal dimension. Unilateral tolerance is used when there is a specific requirement for the dimension to be within a range in one direction, while bilateral tolerance allows for variation in both directions. The choice between unilateral and bilateral tolerance depends on the design requirements, functional considerations, and manufacturing capabilities.

14. What do you mean by section view?

Ans:

A section view is a technique used in engineering and technical drawings to reveal the internal structure, details, and features of an object or system. It involves cutting through the object along a specific plane and showing the resulting cross-section. The purpose of a section view is to provide a clear and detailed representation of the internal components, hidden features, and their relationships.

By using section views, engineers and designers can effectively communicate the internal configuration and geometry of complex objects, highlighting important details that would otherwise be hidden in a regular exterior view. Section views are commonly used in fields such as mechanical engineering, architecture, civil engineering, and manufacturing.

BHARTIYA SKILL DEVELOPMENT UNIVERSITY JAIPUR

Plot No. 005/001-002 | Domestic Tariff Area | Mahindra World City | Jaipur | Rajasthan

www.ruji-bsdu.in | +91 91166 11131

3. Section C

04×06 = 24

15. What do you mean by the layout of an engineering drawing, explained with the help of a proper diagram?

Ans: Any engineering drawing has to follow a standard format. The drawing sheet consist of drawing space, title block and sufficient margins.

A typical drawing sheet consist of the following:

- Borders
- Filling margin
- Grid reference system
- Title box

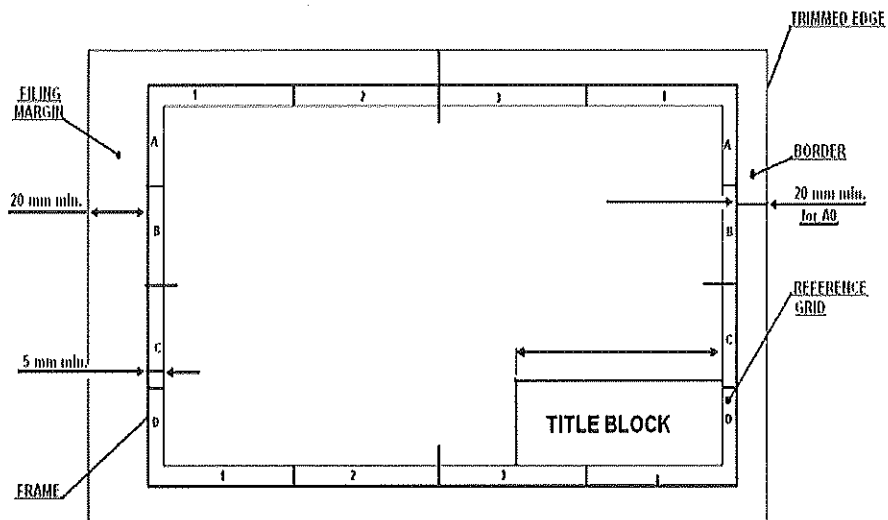

16. What do you mean by section views also explain the difference between a broken section view and a half-section view with the help of a diagram.

Ans:

A broken-out section is used when only a portion of the object needs to be sectioned. The following figure shows a part with a portion removed or broken away. A broken-out section is used instead of a half- or full-section view to save time, and a break line is drawn freehand to represent the jagged edge of the break.

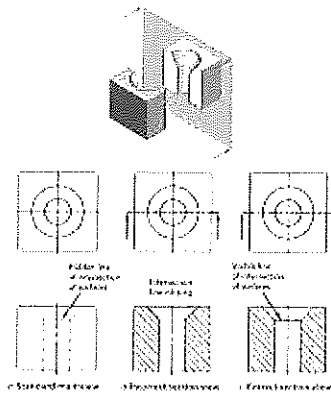

17. Explain any three differences between drawing instruments and accessories.

Ans:

Accessories are the things which when attached with Instruments results in the efficiency of the instruments.

Instrument: instruments are the things which are prime work doing devices without which work can't be completed

18. Write down differences between engineering drawing and artistic drawing?

Ans:

S.no.	Points of difference	Engineering drawing	Artistic drawing
1.	Technical information	It contains technical information Eg: dimensions, symbols and notes	It contains no technical information
2.	manufacturability	It can be manufactured easily in workshops	It can't be manufactured
3.	understandability	It can be understand by technical persons only	It can be understand by all types of persons
4.	examples	-	-



THEORY END-SEM EXAMINATION		
SESSION: 2022-23(WINTER SEMESTER)		
B.Voc/M.Voc	B.Voc.	Semester 3 rd
Course Name / Module	Computer Aided Drawing	
Course Code	GEN1302	
Date		
Name of the Student		Reg. No.

INSTRUCTION:
<ul style="list-style-type: none">● Maximum Marks: 50● Duration of Examination: 2 Hours● Attempt all questions.
SET - B

1. Section A	10×1 = 10
---------------------	------------------

1. What does the abbreviation "DIA" stand for in a dimension such as "DIA 20"?
 - a) Diameter
 - b) Distance
 - c) Diagonal
 - d) Divisor

2. Which of the following is the other name for ELEVATION.
 - a) Front view
 - b) Top view
 - c) Side view
 - d) none of the above

3. Which of the following is used to fix a drawing sheet on a drawing board
 - a) clips
 - b) pins
 - c) adhesive tapes
 - d) drawing pins

4. Which symbol is used to represent a countersink hole in an engineering drawing?
 - a) Triangle
 - b) Circle
 - c) Square
 - d) Hexagon

5. What does the abbreviation "FIL" stand for in a dimension such as "FIL 5"?
 - a) Fillet

Lib0396



- b) Fill
 - c) Fixture
 - d) Flatness
6. Which of the following is the DARKEST pencil of all?
- a) 2B
 - b) HB
 - c) 1H
 - d) 2H
7. What does the abbreviation "SYM" stand for in an engineering drawing?
- a) Symmetry
 - b) Symbol
 - c) System
 - d) Synchronise
8. Which of the following is the correct example of **REDUCING** scale?
- a) 1:2
 - b) 3:2
 - c) 2:1
 - d) 2:0
9. Which of the following statements is true about tolerance in engineering?
- a) A larger tolerance indicates higher precision
 - b) Tolerance is always specified as a positive value
 - c) Tolerance ensures that every part produced is identical
 - d) Tighter tolerances result in higher manufacturing costs
10. In a multi-view drawing, which view shows the object as it appears when viewed from the fside?
- a) Front view
 - b) Top view
 - c) Side view
 - d) Isometric view

2. Section B

04×04 = 16

11. What do you mean by an engineering drawing?
12. Define nominal, basic, and measured sizes with an example each.
13. Give two major uses of the divider with a proper diagram each.
14. Explain proper size ratio in which I & III angle symbols are made with the help of a diagram?



3. Section C

04×06 = 24

15. Explain five different types of lines with a proper diagram?
16. Explain how the first angle is different from the third angle?
17. Write down in brief about the types of section view.
18. Explain what information should be available in an engineering drawing.



THEORY END-SEM EXAMINATION			
SESSION: 2022-23(WINTER SEMESTER)			
B.Voc/M.Voc	B.Voc.	Semester	3 rd
Course Name / Module	Computer Aided Drawing		
Course Code	GEN1302		
Date			
Name of the Student		Reg. No.	

INSTRUCTION:
<ul style="list-style-type: none">● Maximum Marks: 50● Duration of Examination: 2 Hours● Attempt all questions.
SET - B Answer Key

1. Section A	10×1 = 10
---------------------	------------------

1. What does the abbreviation "DIA" stand for in a dimension such as "DIA 20"?
 - a) **Diameter**
 - b) Distance
 - c) Diagonal
 - d) Divisor

2. Which of the following is the other name for ELEVATION.
 - a) **Front view**
 - b) Top view
 - c) Side view
 - d) none of the above

3. Which of the following is used to fix a drawing sheet on a drawing board
 - a) **clips**
 - b) pins
 - c) adhesive tapes
 - d) drawing pins

4. Which symbol is used to represent a countersink hole in an engineering drawing?
 - a) **Triangle**
 - b) Circle
 - c) Square
 - d) Hexagon

5. What does the abbreviation "FIL" stand for in a dimension such as "FIL 5"?
 - a) **Fixture**



- b) Fill
 - c) Fillet**
 - d) Flatness
6. Which of the following is the DARKEST pencil of all?
- a) 2H
 - b) HB
 - c) 1H
 - d) 2B**
7. What does the abbreviation "SYM" stand for in an engineering drawing?
- a) Symbol
 - b) Symmetry**
 - c) System
 - d) Synchronise
8. Which of the following is the correct example of **REDUCING** scale?
- a) 2:1
 - b) 3:2
 - c) 1:2**
 - d) 2:0
9. Which of the following statements is true about tolerance in engineering?
- a) A larger tolerance indicates higher precision
 - b) Tolerance is always specified as a positive value
 - c) Tolerance ensures that every part produced is identical
 - d) Tighter tolerances result in higher manufacturing costs**
10. In a multi-view drawing, which view shows the object as it appears when viewed from the front side?
- a) Front view**
 - b) Top view
 - c) Side view
 - d) Isometric view

2. Section B

04×04 = 16

11. What do you mean by an engineering drawing?

Ans:

Engineering Drawing is the Graphical means of expressing technical details without the barrier of language.

It is the Universal Language for Engineers.

12. Define nominal, basic, and measured sizes with an example each.

Ans:

Nominal size: The nominal size of a dimension is the size by which it is referred to as a matter of convenience.

Basic size: The basic size or normal size is the standard size for the part and is the same both for the hole and its shaft. This is the size that is obtained by calculation for strength.

Measured size: The size which is obtained upon measuring by an instrument.

13. Give two major uses of the divider with a proper diagram each.

Ans:

Divider

The divider looks like a compass, but the difference is the two legs of the divider are provided with needles. This is used to divide a line or curve into equal parts. It is also used to check the measurements. Divider

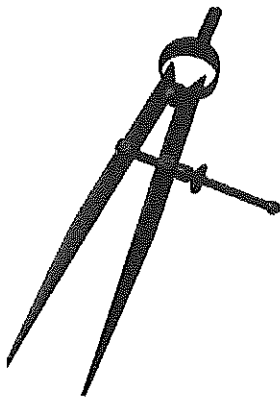

14. Explain proper size ratio in which I & III angle symbols are made with the help of a diagram?

Ans:

The recommended proportions for the symbol are as follows

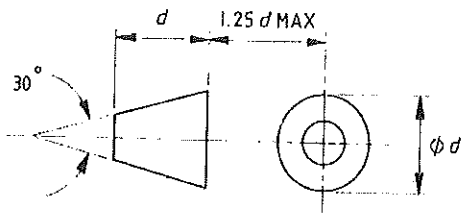







Recommended proportions

3. Section C

04×06 = 24

15. Explain five different types of lines with a proper diagram?

Ans:

Illustration	Application
<p>Thick</p> 	Outlines, visible edges, surface boundaries of objects, margin lines
<p>Continuous thin</p> 	Dimension lines, extension lines, section lines leader or pointer lines, construction lines, boarder lines
<p>Continuous thin wavy</p> 	Short break lines or irregular boundary lines – drawn freehand
<p>Continuous thin with zig-zag</p> 	Long break lines
<p>Short dashes, gap 1, length 3 mm</p> 	Invisible or interior surfaces
<p>Short dashes</p> 	Center lines, locus lines Alternate long and short dashes in a proportion of 6:1,
<p>Long chain thick at end and thin elsewhere</p> 	Cutting plane lines

16. Explain how the first angle is different from the third angle?

Ans:

First angle projection	Third-angle projection
Object is kept in the first quadrant.	Object is assumed to be kept in the third quadrant.
Object lies between observer and the plane of projection.	Plane of projection lies between the observer and the object.
The plane of projection is assumed to be non-transparent.	The plane of projection is assumed to be transparent.
Front (elevation) view is drawn above the XY line	Front (elevation) view is drawn below the XY line
Top (plan) view is drawn below the XY line	Top (plan) view is drawn above the XY line
Left view is projected on the right plane and vice versa	Left view is projected on the left plane itself.
Followed in India, European countries	Followed in USA

17. Write down in brief about the types of section view.

Ans:

6 Types of sectional views

Full sections. This is the most common section (called a full section) with the imaginary laser cutting a line across the entire construction, offering a view of a portion of the building with the rest of it put to one side.

Half sections or views. In this type of section, only half of the space or object is cut away. This allows you to see part of it in elevation, while the other part of the drawing gives a glimpse inside.

Offset sections or views. In an offset section, the cutting plane does not follow a straight line. This might be used, for example, if the architect or engineer wanted to show a section of one room but also the section of another that is located behind it. In other words, while the cutting planes are parallel, the one in one portion of the drawing may be some distance from the plane in another portion.

Broken out sections or broken views. With these drawings, only a small portion of the object or space is shown in section. Instead of a section line, the portion that is shown in section is indicated by an irregular cut line.

Revolving sections or view. With this type of section, a space or detail is shown with a cutting plane at an angle, and then the section is rotated so that the cutting plane faces the viewer.

Removed sections. With a removed section, only a portion of the drawing is shown in section, and this detail is removed to the side. The scale of the section will be different from the main drawing, providing a more detailed perspective.

18. Explain what information should be available in an engineering drawing.

Ans:

BHARTIYA SKILL DEVELOPMENT UNIVERSITY JAIPUR

Plot No. 005/001-002 | Domestic Tariff Area | Mahindra World City |

Jaipur | Rajasthan

www.ruji-bsdu.in | +91 91166 11131



Shape of an object

Exact Sizes and tolerances of various parts of the object

The finish of the product

Machine cost

Machining sequence

The details of materials

Catalogue no. of the product

Date on which the drawing was made

The person who made the drawing

The company's name



THEORY END-SEM EXAMINATION			
SESSION: 2022-23(WINTER SEMESTER)			
B.Voc	Semester	3rd	
Course name / Module	Entrepreneurship Development		
Course code	GEN1303		
Date			
Name of the Student		Reg. No.	
INSTRUCTION:			
<ul style="list-style-type: none">• Maximum Marks: 50• Duration of Examination: 2 Hours• Attempt all questions.			
1. Section A (10 objective type questions, each question carries 01 mark)			10×1 = 10

- 1) Entrepreneurship is both an.....and.....of converting business ideas into.....products or services
 - a) Science, process, innovation
 - b) Art, science, marketable
 - c) Activity, process, marketable
 - d) Subject, process, creative
- 2) Creativity is defined by which of the following sentence?
 - a) The power of human mind to create new contents by transforming relations and generating new correlates is called Creativity
 - b) Creativity involves divergent thinking with respect to the traits of fluency, flexibility and originality of thought process
 - c) Creativity as an imaginative process of generating alternatives for creative problem solving
 - d) All of the above
- 3) Entrepreneurial marketing is defined as-
 - a) The proactive identification and exploitation of opportunities for acquiring and retaining profitable customers
 - b) Set of institutions, and processes for creating, communicating, delivering, and exchanging Brand image that have value for the new venture
 - c) Innovative marketing approaches to risk management, resource leveraging and value creation for new venture
 - d) The proactive identification and exploitation of opportunities for acquiring and retaining existing Market share
- 4) As an entrepreneur, what motivates you to start a new business?
 - 5) Earning money, name & fame
 - 6) Becoming socially independent
 - 7) To be strong and powerful
 - 8) All of the above
- 9) Which one of the following is a common Myth about Entrepreneurs?
 - a) Entrepreneurs are only motivated by money
 - b) Entrepreneurs have great ideas
 - c) Anyone can be an Entrepreneur
 - d) All of the above

BHARTIYA SKILL DEVELOPMENT UNIVERSITY JAIPUR

Plot No. 005/001-002 | Domestic Tariff Area | Mahindra World City | Jaipur | Rajasthan

www.bsd.u.edu.in | +91 91166 11131

Sd/-

1160397

- 10) A Business Plan should have which one of the following information?
- 7M Resources including Land and buildings required
 - Production Operations, Manufacturing Capacity & Manufacturing Process
 - Machinery & equipment along with their prices and specifications
 - All of the above
- 11) Choose the correct option-
- Startup India programme was launched to promote bank financing for start-up ventures
 - Startup India programme was launched to boost entrepreneurship and encourage start-ups with jobs creation.
 - Startup India programme was launched to help the people who have ideas and capabilities and wish to start their own business.
 - All of gthe above
- 12) The Lean Business Planning process involve-
- Creating & testing a Lean Plan i.e. start putting the plan into action to see if your ideas will work
 - Review the results for what changes need to be made & revise the plan as per the feedback & observations
 - A Minimum viable product (MVP) development
 - All of the above
- 13) The institutional support system to entrepreneurs has been designed at which of the following levels:
- Central Government and State Government
 - Non-Government Support System
 - District Industries Centers (DIC) and District Rural Development Authority (DRDA)
 - All of the above
- 14) Which one of the following is a source of funds for financing the new venture?
- Angel Investors
 - New Venture financing companies
 - Private debt Equity
 - External Commercial Borrowings from shareholders

2. Section B (04 short answer type questions, each question carries 04 marks)	04×04 = 16
--	-------------------

- Q.1 Briefly explain the concept and types of Intellectual Property rights.
- Q.2 Briefly discuss the role of Research and Market survey in new venture creation.
- Q.3. Write a brief note about the following:
- SWOT analysis for self discovery
 - Rajasthan Financial Corporation (RFC)
- Q.4. Discuss gthe imporant GST laws for an entrepreneurial business.

3. Section C (04 long type questions, each question carries 06 marks)	04×06 = 24
--	-------------------

- Q.1 Describe the factors impacting emergence of entrepreneurship in the state of Rajasthan.
- Q.2. Who is an Entrepreneur? What are the different types of entrepreneurs you see around? Discuss any two types of such entrepreneurs.
- Q.3. Write brief notes on the following-
- Entrepreneurship Decision Process
 - Opportunity recognition & Validation
- Q.4. Explain the major Challenges in managing and growing an enterprise.

8N

Armi



Ans Keys

SET - C

School of General Education

THEORY END-SEM EXAMINATION			
SESSION: 2022-23(WINTER SEMESTER)			
B.Voc	Semester	3rd	
Course name / Module	Entrepreneurship Development		
Course code	GEN1303		
Date			
Name of the Student			Reg. No.

INSTRUCTION:

- Maximum Marks: 50
- Duration of Examination: 2 Hours
- Attempt all questions.

1. Section A (10 objective type questions, each question carries 01 mark)	10×1 = 10
--	------------------

- 1) Entrepreneurship is both an.....and.....of converting business ideas into.....products or services
 - a) Science, process, innovation
 - b) Art, science, marketable**
 - c) Activity, process, marketable
 - d) Subject, process, creative
- 2) Creativity is defined by which of the following sentence?
 - a) The power of human mind to create new contents by transforming relations and generating new correlates is called Creativity
 - b) Creativity involves divergent thinking with respect to the traits of fluency, flexibility and originality of thought process
 - c) Creativity as an imaginative process of generating alternatives for creative problem solving
 - d) All of the above**
- 3) Entrepreneurial marketing is defined as-
 - a) The proactive identification and exploitation of opportunities for acquiring and retaining profitable customers**
 - b) Set of institutions, and processes for creating, communicating, delivering, and exchanging Brand image that have value for the new venture
 - c) Innovative marketing approaches to risk management, resource leveraging and value creation for new venture
 - d) The proactive identification and exploitation of opportunities for acquiring and retaining existing Market share
- 4) As an entrepreneur, what motivates you to start a new business?
 - a) Earning money, name & fame**
 - b) Becoming socially independent
 - c) To be strong and powerful
 - d) All of the above
- 5) Which one of the following is a common Myth about Entrepreneurs?
 - a) Entrepreneurs are only motivated by money
 - b) Entrepreneurs have great ideas
 - c) Anyone can be an Entrepreneur
 - d) All of the above**

BHARTIYA SKILL DEVELOPMENT UNIVERSITY JAIPUR

Plot No. 005/001-002 | Domestic Tariff Area | Mahindra World City | Jaipur | Rajasthan

www.ru-bdpu.in | +91 91166 11131

1210397

- 6) A Business Plan should have which one of the following information?
- 7M Resources including Land and buildings required
 - Production Operations, Manufacturing Capacity & Manufacturing Process
 - Machinery & equipment along with their prices and specifications
 - d) All of the above**
- 7) Choose the correct option-
- Startup India programme was launched to promote bank financing for start-up ventures
 - Startup India programme was launched to boost entrepreneurship and encourage start-ups with jobs creation.
 - Startup India programme was launched to help the people who have ideas and capabilities and wish to start their own business.
 - d) All of gthe above**
- 8) The Lean Business Planning process involve-
- Creating & testing a Lean Plan i.e. start putting the plan into action to see if your ideas will work
 - Review the results for what changes need to be made & revise the plan as per the feedback & observations
 - A Minimum viable product (MVP) development
 - d) All of the above**
- 9) The institutional support system to entrepreneurs has been designed at which of the following levels:
- Central Government and State Government
 - Non-Government Support System
 - District Industries Centers (DIC) and District Rural Development Authority (DRDA)
 - d) All of the above**
- 10) Which one of the following is a source of funds for financing the new venture?
- a) Angel Investors**
 - New Venture financing companies
 - Private debt Equity
 - External Commercial Borrowings from shareholders

2. Section B (04 short answer type questions, each question carries 04 marks)

04×04 = 16

Q.1 Briefly explain the concept and types of Intellectual Property rights.

Answer- One of an entrepreneur's most valuable assets is their intellectual property. Intellectual property, which refers to creations of the human mind, includes patents, trademarks, copyrights, and trade secrets. These help lead to monetization and growth for entrepreneurs who want to scale their ideas and companies. While many perceive intellectual property protection as cost-prohibitive, there are low-cost strategies that new entrepreneurs should consider using.

Intellectual Property Rights (IPR)

Intellectual property rights refers to the general term for the assignment of property rights through patents, copyrights and trademarks. These property rights allow the holder to exercise a monopoly on the use of the item for a specified period.

By restricting imitation and duplication, monopoly power is conferred, but the social costs of monopoly power may be offset by the social benefits of higher levels of creative activity encouraged by the monopoly earnings.

Different types of Intellectual Property rights are as under-

1. Patents
2. Trademarks
3. Copyrights

Patents: A Patent is a right granted to an inventor that allows them to prevent or exclude all others from making, using, or selling their invention for 20 years. The goal of the patent system is to encourage inventors to advance the state of technology by awarding them special rights to benefit from their inventions.

Trademarks: A trademark (popularly known as brand name) in layman's language is a visual symbol which may be a word signature, name, device, label, numerals or combination of Colors used by one undertaking on goods or services or other articles of commerce to distinguish it from other similar goods or services originating from a different undertaking.

Copy rights: Copyright is a right given by the law to creators of literary, dramatic, musical and artistic works and producers of cinematograph films and sound recordings. In fact, it is a bundle of rights including, inter alia, rights of reproduction, communication to the public, adaptation and translation of the work. There could be slight variations in the composition of the rights depending on the work. Copyright ensures certain minimum safeguards of the rights of authors over their creations, thereby protecting and rewarding creativity.

Q.2 Briefly discuss the role of Research and Market survey in new venture creation.

Answer- **Research** is defined as the creation of new knowledge and/or the use of existing knowledge in a new and creative way so as to generate new concepts, methodologies and understandings. This is a careful consideration of study regarding a particular concern or problem using scientific methods.

Market research is an information-gathering tool for business (and potential business) owners to gain knowledge about how well their product will do in the current market, what the demand is, and how consumers will react to their product.

Market survey is a Research tool to directly collect feedback from the target audience to understand their characteristics, expectations, and requirements. Data gathered using market surveys is instrumental in making well-informed business decisions.

An Entrepreneur or any potential entrepreneurs start off as an idea in the mind and turning these ideas into viable business propositions is the undoubted challenge for them. And here comes the role of Market Research and surveys to address their concern at different stages of their entrepreneurial journey right from exploring and assessing the new business ideas to opportunity recognition to the conception of viable business propositions and further planning, organizing & building a new business, running and managing the day to day affairs of the new venture and taking the business to the next level, scaling up, developing and growing.

This all requires the relevant data/information/knowledge to make the well informed decisions throughout the entrepreneurial journey to be successful or bounce back from the situations of failure.

Q.3. Write a brief note about the following:

1. SWOT analysis for self discovery

Answer- **SWOT is an acronym that stands for: Strength, Weakness, Opportunity, Threat.** SWOT analysis is an important tool for Self-Discovery and Assessment. This analysis helps in assessing strengths and weaknesses (S-W), as well as broader opportunities and threats (O-T) before an individual or any organisation.

Generally, strengths (such as the ability to change quickly) and weaknesses (such as lack of communication skills) are internal to an individual, while opportunities and threats tend to be external (in the immediate surrounding or the wider Socio-economic, personal & professional environment).

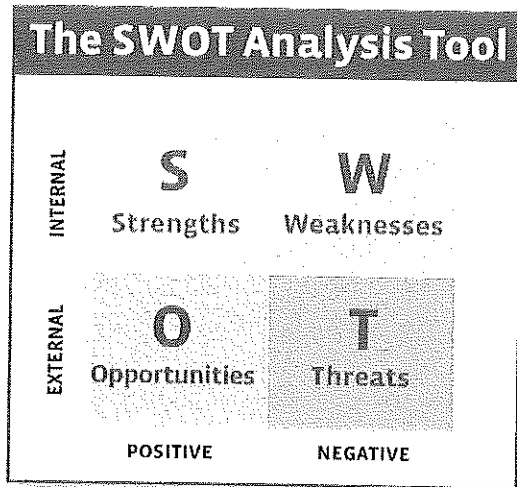

What each area of SWOT MATRIX represents

Strengths: Internal advantages that motivates actions or enhances performance or enable someone to do something.

Weaknesses: Internal disadvantages that compromise, or hampers the actions of an individual or intentions to do something.

Opportunities: External factors or situations that are beneficial for an individual or that could be advancing an individual's competitive advantage.

Threats: External threats or situations that are detrimental or which are potentially harmful to an Individual

2. Rajasthan Financial Corporation (RFC)

Answer- State Financial Corporations like Rajasthan Financial Corporation (RFC) in Rajasthan State and HFC in Haryana etc. SFCs help in ensuring balanced regional development, higher investment, more employment generation and broad ownership of various industries in the respective state.

RFC stands for Rajasthan Financial Corporation.

RFC is the apex State Financial Corporation (SFC) in the state for providing long term financial support to tiny, small and medium scale industries in the State of Rajasthan.

- RFC has network of 21 Branch offices and one Facilitation Center in the State . You may discuss your project with our Branch Managers and submit your application to the concerned Branch in whose jurisdiction you propose to set up your industrial unit.
- RFC have launched Youth Entrepreneurship Development Programme in the state of Rajasthan to help support the educated youth to start their own Micro & Small level industry or service enterprises in the state. Through this scheme Loan is provided at cheaper rate of interest.

Q.4. Discuss the important GST laws for an entrepreneurial business.

Answer- GST is a transparent system of tax administration. Most of the compliances including taxpayer registration, return submission, tax payment and refund claims will be online. This will help entrepreneurs to focus on their business rather than being worried about tax compliances.

Compliance under GST are simple and easy to follow. Many small businesses lack resources to hire experts or deploy a dedicated resource to look after their compliance requirements.

However, under the GST law, all compliances have been streamlined and made simple for the benefit of taxpayers. An entrepreneur can adhere to the compliances by himself under a "Self-Assessment" model.

Goods & Services Tax (GST) for Entrepreneurs.

- GST Laws for Small Scale Entrepreneurs- Small businesses with a turnover of less than Rs. 20 lakhs (Rs. 10 lakhs in N-E states, Uttarakhand & Himachal Pradesh) are outside GST net. They need not register or pay tax, unless they wish to avail benefit of input tax credit. This is a big shift from the existing system of indirect taxes where the businessmen had to register under VAT and Service Tax if their turnover crossed Rs.10 Lakhs (Rs. 5 Lakhs in special category States). Thus, effectively threshold for registration has been doubled.
- GST Laws for Medium Scale Entrepreneurs- For medium scale businessmen whose turnover exceeds Rs. 20 Lakhs, registration would be compulsory. However, business dealing in only intra state supplies of goods like small traders, manufacturers and restaurants, with a turnover of up to Rs.75 lakhs (50 Lakhs for 9 special category States), have the option to pay tax under Composition levy scheme.
- Other Entrepreneurs - All businesses whose turnover exceeds Rs.20 Lakhs will need to register under GST. However, registration will prove to be a boon rather than a bane under GST. Registration will enable businesses to partner with Government in tax collection. There will be no cascading of taxes, because of the systematic input tax credit along the full value chain. Thus effectively only the value addition will be taxed at every stage of the supply chain.
- Conclusion- To conclude, GST is set to benefit entrepreneurs of all kind, with a transformational shift in the indirect tax administration in India. GST will be an enabler and facilitator for entrepreneurs when it comes to doing business.

3. Section C (04 long type questions, each question carries 06 marks)	04×06 = 24
--	-------------------

Q.1 Describe the factors impacting emergence of entrepreneurship in the state of Rajasthan.

Answer- Entrepreneurship is a human skill, which can be developed. Due to entrepreneurship development, living standards of society can tend to rise, new opportunities of employment can be created and rapid economic and industrial development become possible. There are large number of varied factors which contributes to the growth of Entrepreneurship in India and specially in the state of Rajasthan. All the relevant factors impacting emergence of entrepreneurship in the state of Rajasthan are classified as under-

- I. Economic Factors: Capital, Labor, Raw Material, Market and Infrastructure etc.
- II. Social Factors: Caste Factor, Family background, Education, Attitude of the Society, Cultural Values etc.
- III. Psychological Factors: Need Achievement, Withdrawal of Status Respect, Motives,
- IV. Contextual Factors and Entrepreneurial Eco-System
- V. Technological, Natural, Political, Regulatory, Legal & Governmental Factors

Further, the individual factors impacting emergence of entrepreneurship are listed under as well-

1. Aspiration and Attitude
2. Personal/Psychological Factors
3. Family Circumstances
4. Government Policies, Facilities, and Incentives
5. Social-Economic and Cultural Factors
6. Institutional Support System
7. Political/Legal/Taxation Regime
8. Economic and Business Environment
9. Entrepreneurship Oriented Education and Training
10. Attitude of Big Entrepreneurs

The Role of Factors Related to Individual Entrepreneur

Entrepreneur is an individual having specific knowledge, skills and efficiency. Any new enterprise is created by an individual or group of individuals. The creativity of an individual encourages him to establish a new enterprise. Creativity consists of innovation, search and research. Personality, social conditions, social support, education and training etc. factors lay an important role for developing such skills and motivate an individual to become an entrepreneur.

Q.2. Who is an Entrepreneur? What are the different types of entrepreneurs you see around? Discuss any two types of such entrepreneurs.

Answer- An entrepreneur is a person who has a passion for creation and the ability to follow through on their ideas, someone who has the ability to see a need that has previously not been addressed or in some cases created a need that didn't even exist. Entrepreneurs want to work for themselves and are willing to take risks in order for their ideas or products to succeed.

So in simple words, Entrepreneur is a person with a mind-set of creating something new with value (Innovation) by devoting the necessary time and efforts and build a new business around the innovation by organising resources to fulfil the needs of the target market and in return receiving the resulting rewards of monetary and personal satisfaction and independence.

Different types of Entrepreneurs

- (1) According to the types of business**
 - Trading Entrepreneur
 - Industrial Entrepreneur
 - Agricultural Entrepreneur
 - Service Entrepreneur
 - Corporate Entrepreneurs
- (2) According to the use of technology**
 - Technical Entrepreneur
 - Non-technical Entrepreneur
- (3) According the Area**
 - Urban Entrepreneur
 - Rural Entrepreneur
- (4) According to gender**
 - Men Entrepreneur
 - Women Entrepreneur
- (5) Based on Ownership**
 - Solopreneurs
- (6) Based on Clarence Danhoff Study**
 - Innovative Entrepreneurs
 - Imitative Entrepreneurs/ Adaptive Entrepreneurs
 - Fabian Entrepreneurs
 - Drone Entrepreneurs
- (7) Other Entrepreneurs**
 - Micro Entrepreneurs
 - Small-Scale Entrepreneurs
 - Startup Entrepreneurs
 - Intrapreneurs
 - Social Entrepreneurs
 - Induced Entrepreneurs

- IT Entrepreneurs
- First-Generation Entrepreneurs
- A Serial Entrepreneur
- Motivated Entrepreneurs

Description of Two types of Entrepreneurs around us-

- **Innovators:** Introduce new product or service or initiate a new system in the economy or the environment. Example: Henry Ford wanted to replace the petrol fuel or the diesel engine with the Kerosene fuel system.
- **Imitators or Adaptive Entrepreneurs:** They iterate a certain feature or innovation in a particular product to make it more appealing and have a competitive edge over the current market. Adaptive or imitative entrepreneurs are ready to adopt successful innovations created by innovative entrepreneurs.

Q.3. Write brief notes on the following-

1. Entrepreneurship Decision Process

Answer- **Entrepreneurial Decision Process** is about deciding to become an entrepreneur by leaving present activity i.e. a movement from the present lifestyle to forming a new enterprise. The decision to start a new company occurs when an individual perceives that forming a new enterprise is both desirable and possible.

This process is different from the Entrepreneurial Process where a new venture is created by an entrepreneur and involve finding, evaluating, and developing an opportunity by overcoming the strong forces that resist the creation of something new. Entrepreneurial Decision Process is about the decision to become an entrepreneur and to start a new business consist of several sequential steps-

- **The decision to leave a present career or lifestyle** (Pushing and pulling influences active in the decision to leave a present career or lifestyle)
- **The decision about desirability of new venture formation** i.e. the aspects of a situation that make it desirable to start a new venture and this relates to culture, subculture, family, teachers and peers.
- **The decision about possibility of new venture formation** i.e. factors making it possible to create a new venture like government, background, marketing, financial, role models.

2. Opportunity recognition & Validation

Answer- The Concept of Opportunity for an entrepreneur refers to a favorable set of circumstances that creates a need for a new product i.e. the circumstances that creates a need for a new service or A set of circumstances that creates a need for a new business

The elements of opportunity include.....

- Commercial attractiveness
- Timely
- Durable

Opportunity Recognition

This involve the careful screening and evaluation of the identified set of circumstances related to the business ideas to clearly define the viable business opportunity.

The evaluation process involves looking at-

- a. The creation and length of the opportunity
- b. Its real and perceived value
- c. Its risks and return.
- d. It's fit with the skills and goals of the entrepreneur

- e. Its differential advantage in its competitive environment
- f. It is important to understand the cause of the opportunity, as the resulting opportunity may have a different market size and time dimension.

Q.4. Explain the major Challenges in managing and growing an enterprise.

Answer- **Challenges in Managing and growing an enterprise:** Following are the Biggest Challenges for New Entrepreneurs:

Financing: As a new entrepreneur, you'll be starting from scratch, which means you'll need to start networking like crazy and thinking through all your possible funding options before landing on one.

Team Building: Picking the right team for a startup is stressful and difficult. It's not enough to find candidates who fill certain roles -- you also need to consider their cost to the business, their culture fit and how they'll work as part of your overall team.

Being the visionary: As a new entrepreneur is expected to come up with the ideas. When a competitor emerges, it will be your responsibility to come up with a response plan. When your team hits an impenetrable obstacle, your job will be to come up with an alternative plan to move forward. This demands on-the-spot creative thinking.

Dealing with the unknown: How long will your business exist? How profitable will your business be? Will customers like your product? None of these questions has a solid, reliable answer, even in startups based on great ideas. Dealing with this volatility is one of the hardest parts of emerging as a new entrepreneur.

Decision-making: Believe it or not, this is probably the most stressful challenge in managing and growing your startup enterprise. As a new entrepreneur, you are forced to make hundreds of decisions a day, from big, company-impacting decisions, to tiny, hour-affecting ones. Decision fatigue is a real challenge, and most new entrepreneurs will experience it if they aren't prepared for the new level of stress.

Managerial Challenges: Related to Day-to-day planning and organizing to operate the business.

THEORY END-SEM EXAMINATION			
SESSION: 2022-23(WINTER SEMESTER)			
B.Voc	Semester	3 rd	
Course Name / Module	Personality Development		
Course Code	GEN1304		
Date			
Name of the Student		Reg. No.	

INSTRUCTION:

- Maximum Marks: 50
- Duration of Examination: 2 Hours
- Attempt all questions.

1. Section A (10 objective type questions, each question carries 01 mark)

10×1 = 10

- Q1. Which among the given options is the full form of 'bcc' in an E-mail format
- Black colourful copy
 - Black column copy
 - Blind casual copy
 - Blind carbon copy
- Q2. Match 'O' in the acronym 'SWOT' with the correct option.
- Option
 - Over
 - Opportunity
 - Odd
- Q3. Participating in sports because you want to win the trophy is an example of ____.
- Extrinsic motivation
 - Time management
 - Intrinsic motivation
 - Out of box thinking
- Q4. 'S' in the term SMART goals stands for ____.
- Simple
 - Specific
 - Silent
 - Stubborn
- Q5. The term nearest in meaning to "Good Manners" is ____.
- Motive
 - Etiquette
 - Goal
 - None of the above
- Q6. ____ should be avoided in email writing.
- Thoughtfulness
 - Joke and sarcasm
 - Correct Grammar
 - Polite Language

- Q7. _____ is an indirect and creative approach of solving problems .
- a) Lateral Thinking
 - b) Negative Attitud
 - c) None of the above
 - d) Stress Management
- Q8. Goals that take more time to achieve are known as:
- a) Complex goals
 - b) Passive goals
 - c) Short term goals
 - d) Long term goals
- Q9. The full form of E- Mail is:
- a) Electric Mail
 - b) Electronic Mail
 - c) Exchange mail
 - d) None of the above
- Q10. The letter 'A' in the acronym ' SMART' goals stands for:
- a) Amazing
 - b) Achievable
 - c) Attitude
 - d) Average

2. Section B (04 short answer type questions, each question carries 04 marks)	04×04 = 16
--	-------------------

- Q11. What is stress ? Explain the importance of Stress Management in a student's life.
- Q12. Write a few advantages of setting goals.
- Q13. Write a note on Extrinsic and Intrinsic motivation. Give examples
- Q 14. Explain the correlation of Strengths and Opportunities with reference to SWOT Analysis.

3. Section C (04 long type questions, each question carries 06 marks)	04×06 = 24
--	-------------------

- Q15. Design a detailed blue print of your long term goals to help you to achieve them
- Q 16. How does Lateral thinking help in deriving creative solutions? Explain the techniques utilized in Lateral thinking.
- Q17. Draft an email to the Principal of your School requesting him to permit you to submit your assignment after the due date. State the relevant reasons.
- Q18. Explain in detail the major types of goals.

THEORY END-SEM EXAMINATION			
SESSION: 2022-23(WINTER SEMESTER)			
B.Voc	Semester	3 rd	
Course Name / Module	Personality Development		
Course Code	GEN1304		
Date			
Name of the Student		Reg. No.	

INSTRUCTION:
• ANSWER KEYS SET B

1. Section A (10 objective type questions, each question carries 01 mark)	10×1 = 10
--	------------------

Q1. Which among the given options is the full form of 'bcc' in an E-mail format

- a) Black colourful copy
- b) Black column copy
- c) Blind casual copy
- d) Blind carbon copy**

Q2. Match 'O' in the acronym 'SWOT' with the correct option.

- a) Option
- b) Over
- c) Opportunity**
- d) Odd

Q3. Participating in sports because you want to win awards is an example of _____.

- a) Extrinsic motivation
- b) Time management
- c) Intrinsic motivation**
- d) Out of box thinking

Q4. 'S' in the term SMART goals stands for _____.

- a) Simple
- b) Specific**
- c) Silent
- d) Stubborn

Q5. The term nearest in meaning to "Good Manners" is _____

- a) Motive
- b) Etiquette**
- c) Goal
- d) None of the above

Q6. _____ should be avoided in email writing?

- a) Thoughtfulness
- b) Joke and sarcasm**
- c) Correct Grammar
- d) Polite Language

Q7. _____ is an indirect and creative approach of solving problems .

- a) Lateral Thinking**

- b) Negative Attitud
- c) None of the above
- d) Stress Management

Q8. Goals that take a more time to achieve are known as

- a) Complex goals
- b) Passive goals
- c) Short term goals
- d) Long term goals**

Q9. The full form of E Mail is

- a) Electric Mail
- b) Electronic Mail**
- c) Exchange mail
- d) None of the above

Q10. The letter 'A' in the acronym 'SMART' goals stands for:

- a) Amazing
- b) Achievable**
- c) Attitude
- d) Average

2. Section B (04 short answer type questions, each question carries 04 marks)	04×04 = 16
--	-------------------

Q11. What is stress ? Explain the importance of Stress Management in a student's life.

Stress is a physical, mental or emotional factor that causes tension in the mind or body. Stress management helps in improved concentration, reduces negativity, enhances critical thinking, results in discipline and purpose oriented life. It helps to have a better control over self and situations.

Q12. Write a few advantages of setting goals.

- provides Direction.
- Clearer Focus on what is important.
- Clarity in Decision Making
- Gives you control of your future.
- Provides Motivation.
- Gives you a sense of personal satisfaction
- Gives you a sense of purpose in life

Q13. Write a note on Extrinsic and Intrinsic motivation. Give examples

Extrinsic motivation occurs when we are motivated to perform a behaviour or engage in an activity to earn a reward or avoid punishment.

Examples of behaviours that are the result of extrinsic motivation include:

- Studying because you want to get a good grade
- Cleaning your room to avoid being reprimanded by your parents
- Participating in a sport to win awards
- Competing in a contest to win a scholarship

In each of these examples, the behaviour is motivated by a desire to gain a reward or avoid an adverse outcome. People are engaging in a behaviour not because they enjoy it or because they find it satisfying, but in order to get something in return or avoid something unpleasant.

What Is Intrinsic Motivation?

Intrinsic motivation involves engaging in a behaviour because it is personally rewarding; essentially, performing an activity for its own sake rather than the desire for some external reward.

Examples of actions that are the result of intrinsic motivation include:

- Participating in a sport because you find the activity enjoyable

- Solving a word puzzle because you find the challenge fun and exciting
- Playing a game because you find it exciting

In each of these instances, the person's behaviour is motivated by an internal desire to participate in an activity for its own sake.

Essentially, the behaviour itself is its own reward.

Q 14. Explain the correlation of Strengths and Opportunities with reference to SWOT Analysis.

A strength is a resource or capacity the organisation can use effectively to achieve its objectives. An opportunity is any favourable situation in the organisation's environment.

3. Section C (04 long type questions, each question carries 06 marks)

04×06 = 24

Q15. Design a detailed blue print of your long term goals to help you to achieve them.

As per the blue print format circulated to students.

Q 16. How does Lateral thinking help in deriving creative solutions? Explain the 7 techniques utilized in Lateral thinking .

Lateral thinking is solving problems through an indirect and creative approach. This type of thinking involves moving away from the traditional type of thinking in solving a problem. This term was introduced by Edward De Bono in 1967 in his book "the use of Lateral Thinking". Usually a problem is solved using a step-by-step and logical approach. He believed that moving away from the direct approach and thinking of unusual ways to solve a problem are sometimes very useful. Students are required to state examples in the support of their answers.

1. Alternatives

This technique is about using concepts as a base for new ideas. Concepts are general theories or ways of doing things. Thinking of a number of ways to implement a concept is one way to generate ideas. Each idea can then generate new concepts. These new concepts can create a whole new way for generating more ideas.

2. Focus

This technique is about learning when and how to change your focus to improve creative thinking. You can train your mind to focus on areas other people have not thought of. You may be able to make a breakthrough just because other people have not thought of it.

3. Challenge

In this technique you break free from the boundaries of traditional thinking and the accepted way of doing things. It is based on the assumption that there may be a different and better way to do something even if there is no obvious problem with the current way.

4. Random Entry

This technique is about using unconnected input to open up new lines of thinking. With this, you can use a randomly chosen word, picture, sound or other stimulus to open new lines of thinking.

5. Provocation and Movement

This technique is about generating provoking thoughts and using them to build new ideas. It enables you to think outside the box to get a list of interesting ideas to consider.

6. Harvesting

This technique involves selecting specific ideas that seem practical and have the most value then reshaping them into practical solutions. It is about turning starter ideas into workable ideas. This technique is done at the end of a thinking session in order to select ideas that may prove to be valuable in the current situation or in the future. Harvesting helps you identify ideas that could be implemented right away as well as those that may need more work.

Q17. Draft an email to the Principal of your School requesting him to permit you to submit your assignment after the due date. State the relevant reasons.

Senders' address, cc, bcc, salutations, greetings, writing the purpose, request for the required action, complimentary closing

Q18. Explain in detail the major types of goals.

Elaborate on short term, long term, fixed and flexible goals

THEORY END-SEM EXAMINATION			
SESSION: 2022-23 (WINTER SEMESTER)			
B.Voc/M.Voc	B.Voc	Semester	3 rd
Course Name / Module	Elementary Drawing		
Course Code	GEN1305		
Date			
Name of the Student		Reg. No.	

INSTRUCTION:
<ul style="list-style-type: none"> • Maximum Marks: 50 • Duration of Examination: 2 Hours • Attempt all questions.
SET-B

Section A	10×1 = 10
-----------	-----------

- What is the difference between a leader line and a dimension line?
 - A leader line points to the dimension, while a dimension line points to the object.
 - A leader line is used for annotations, while a dimension line is used for measurements.
 - A leader line is a continuous line, while a dimension line is a broken line.
 - A leader line is always horizontal, while a dimension line is always vertical.
- What is the purpose of dimensioning in engineering drawing?
 - To specify the size and shape of an object.
 - To add visual interest to a drawing.
 - To show different views of an object.
 - To indicate the material used in an object.
- What is the purpose of geometric dimensioning and tolerancing (GD&T)?
 - To specify the form, orientation, and location of features on an object.
 - To indicate the material used in an object.
 - To show different views of an object.
 - To add visual interest to a drawing.
- What is a datum feature?
 - A feature that is used as a reference for other features on the object.
 - A feature that is not critical to the function of the object.
 - A feature that is added for aesthetic purposes.
 - A feature that is not dimensioned or toleranced.

5. What is the purpose of a section view in an engineering drawing?
 - a. To show the hidden details of an object.
 - b. To add visual interest to a drawing.
 - c. To show different views of an object.
 - d. To indicate the material used in an object.

6. What is a runout tolerance?
 - a. A tolerance that controls the perpendicularity of a feature to a datum plane.
 - b. A tolerance that controls the location of a feature relative to a datum plane.
 - c. A tolerance that controls the roundness of a feature.
 - d. A tolerance that controls the total variation of a feature as it rotates about an axis.

7. What is the purpose of scaling in engineering drawings?
 - a. To reduce the size of the drawing to fit on a standard sheet of paper
 - b. To increase the size of the drawing for better visibility
 - c. To represent the object's size accurately on paper
 - d. To make the drawing look more aesthetically pleasing

8. Which of the following is NOT a type of projection used in engineering drawing?
 - a. parallel projection
 - b. Orthographic projection
 - c. Perspective projection
 - d. Isometric projection

9. What is the purpose of a projection plane in engineering drawing?
 - a. To show the orientation of the object being projected.
 - b. To create a two-dimensional image of a three-dimensional object.
 - c. To create a three-dimensional model of a two-dimensional object.
 - d. To indicate the scale used in the drawing.

10. Which of the following is NOT a standard view orientation in an engineering drawing?
 - a. Top view
 - b. Front view
 - c. Left view
 - d. Isometric view

Section B	04×04 = 16
------------------	-------------------

11. What is the difference between engineering drawing and artistic drawing?
12. Give the list of drawing instruments and accessories.
13. What are the different stages in industry where engineering drawings are used?
14. What is average roughness value?

Section C

04×06 = 24

15. What is third angle projection? Explain in detail and also draw its symbol
16. What is line? Explain different types of lines and their applications.
17. What is scaling system? Explain its types and uses.
18. Draw Front view, Top View and Right hand side view for following object, using First angle projection method. The Front view is to be drawn by looking in the direction of X.

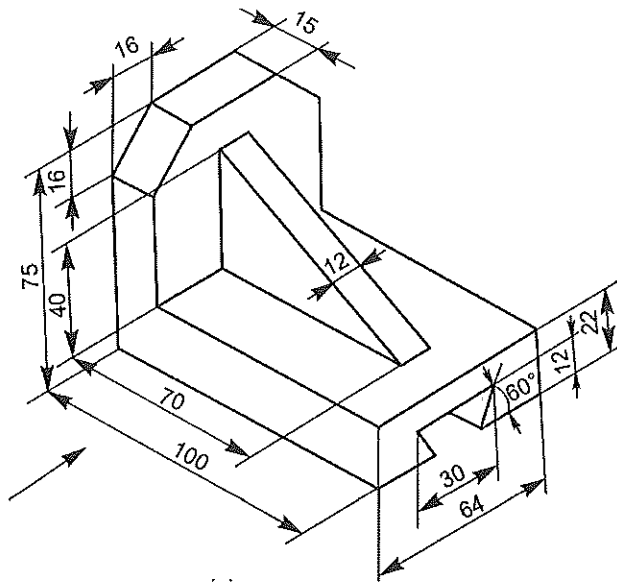
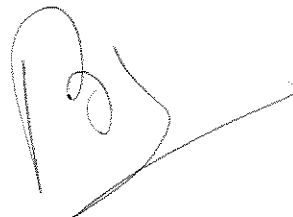
THEORY END-SEM EXAMINATION			
SESSION: 2022-23 (WINTER SEMESTER)			
B.Voc/M.Voc	B.Voc	Semester	3 rd
Course Name / Module	Elementary Drawing		
Course Code	GEN1305		
Date			
Name of the Student		Reg. No.	

INSTRUCTION:
<ul style="list-style-type: none"> • Maximum Marks: 50 • Duration of Examination: 2 Hours • Attempt all questions.
SET-B

Section A	10×1 = 10
-----------	-----------

- What is the difference between a leader line and a dimension line?
 - A leader line points to the dimension, while a dimension line points to the object.
 - A leader line is used for annotations, while a dimension line is used for measurements.**
 - A leader line is a continuous line, while a dimension line is a broken line.
 - A leader line is always horizontal, while a dimension line is always vertical.

Ans: B

- What is the purpose of dimensioning in engineering drawing?
 - To specify the size and shape of an object.**
 - To add visual interest to a drawing.
 - To show different views of an object.
 - To indicate the material used in an object.

Ans: A

- What is the purpose of geometric dimensioning and tolerancing (GD&T)?
 - To specify the form, orientation, and location of features on an object.**
 - To indicate the material used in an object.
 - To show different views of an object.
 - To add visual interest to a drawing.

Ans: A

- What is a datum feature?
 - A feature that is used as a reference for other features on the object.**
 - A feature that is not critical to the function of the object.
 - A feature that is added for aesthetic purposes.
 - A feature that is not dimensioned or toleranced.

Ans: A

5. What is the purpose of a section view in an engineering drawing?
- To show the hidden details of an object.**
 - To add visual interest to a drawing.
 - To show different views of an object.
 - To indicate the material used in an object.

Ans: A

6. What is a runout tolerance?
- A tolerance that controls the perpendicularity of a feature to a datum plane.
 - A tolerance that controls the location of a feature relative to a datum plane.
 - A tolerance that controls the roundness of a feature.
 - A tolerance that controls the total variation of a feature as it rotates about an axis.**

Ans: D

7. What is the purpose of scaling in engineering drawings?
- To reduce the size of the drawing to fit on a standard sheet of paper
 - To increase the size of the drawing for better visibility
 - To represent the object's size accurately on paper**
 - To make the drawing look more aesthetically pleasing

Ans: C

8. Which of the following is NOT a type of projection used in engineering drawing?
- parallel projection
 - Orthographic projection
 - Perspective projection
 - Isometric projection**

Ans: D

9. What is the purpose of a projection plane in engineering drawing?
- To show the orientation of the object being projected.
 - To create a two-dimensional image of a three-dimensional object.**
 - To create a three-dimensional model of a two-dimensional object.
 - To indicate the scale used in the drawing.

Ans: B

10. Which of the following is NOT a standard view orientation in an engineering drawing?
- Top view
 - Front view
 - Left view
 - Isometric view**

Ans: D

Section B

04×04 = 16

11. What is the difference between engineering drawing and artistic drawing?

Ans: The art of representing engineering objects such as buildings, roads, machines, circuits etc. on a paper is called engineering drawing. artistic drawing is to convey emotion or artistic sensitivity in some way.

Purpose of engineering drawing is to convey information about engineering object or idea.

12. Give the list of drawing instruments and accessories.

- 1) Ans: Drawing Board
- 2) Drawing sheet
- 3) Mini-drafter
- 4) Set-square
- 5) Compas
- 6) Divider
- 7) Pencil
- 8) French curve

13. What are the different stages in industry where engineering drawings are used?

Ans: **IN AN INDUSTRY, THESE DRAWINGS HELP BOTH THE TECHNICAL AS WELL AS COMMERCIAL STAFFS AT VARIOUS STAGES LIKE:**

- Ans: Conceptual stage
- Design stage
- Modification stage
- Prototype development stage
- Process and production planning
- Production
- Inspection
- Marketing
- Servicing and maintenance, etc.

14. What is average roughness value?

Ans: Average Roughness, or Ra, is the most commonly specified surface texture parameter. It provides a general measure of the height of the texture across a surface. More exactly, Ra is the average of how far each point on the surface deviates in height from the mean height

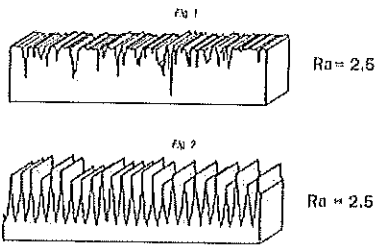

Section C	04×06 = 24
------------------	-------------------

15. What is third angle projection? Explain in detail and also draw its symbol

Ans: **THIRD ANGLE PROJECTION**

- In the third angle projection method, the object is assumed to be in the third quadrant. i.e. the object behind vertical plane and below the horizontal plane.

In this projection technique, Placing the object in the third quadrant puts the projection planes between the viewer and the object

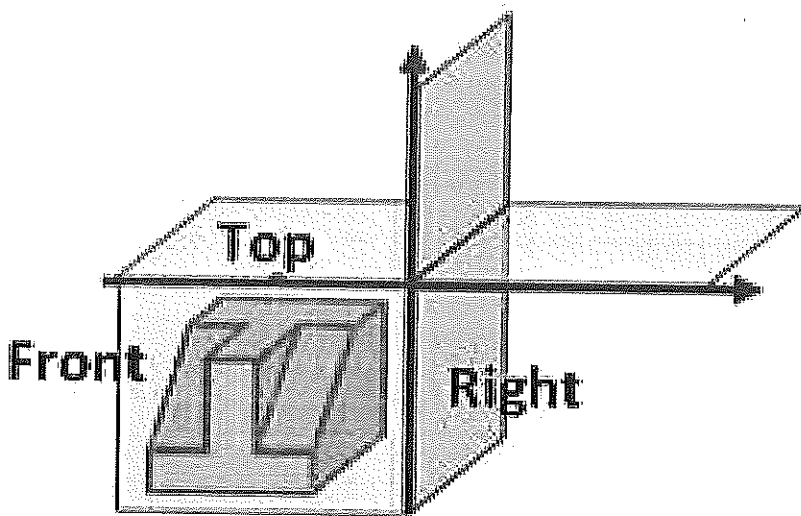

Third Angle

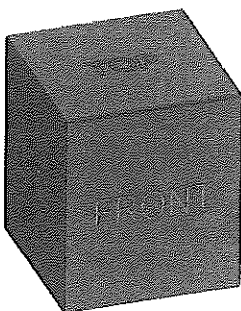
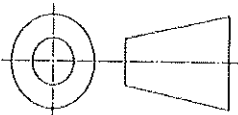



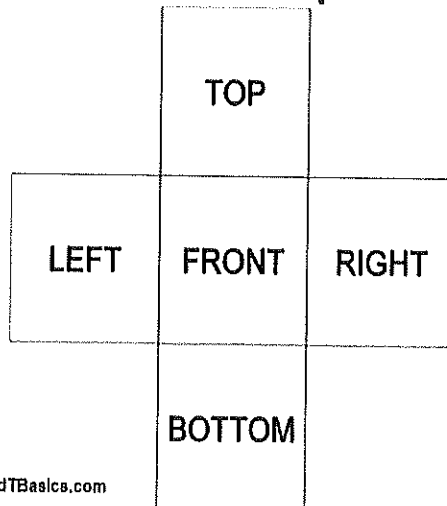



GD&T BASICS Presented By:  ENGINEER ESSENTIALS



16. What is line? Explain different types of lines and their applications.

- Ans: Lines are always used to construct meaningful drawings.
- A line may be curved, straight, continuous, segmented. It may be drawn as thin or thick

Illustration	Application
	Outlines, visible edges, surface boundaries of objects, margin lines
	Dimension lines, extension lines, section lines leader or pointer lines, construction lines, boarder lines
	Short break lines or irregular boundary lines – drawn freehand
	Long break lines
	Invisible or interior surfaces
	Center lines, locus lines Alternate long and short dashes in a proportion of 6:1,
	Cutting plane lines

17. What is scaling system? Explain its types and uses.

Ans: Scale is the ratio of the linear dimension of an element of an object as represented in the drawing, to the real linear dimension of the same element of the object itself.

Wherever possible, it is desirable to make full size drawings, so as to represent true shapes and sizes. If this is not practicable, the largest possible scale should be used.

While drawing very small objects, such as watch components and other similar objects, it is advisable to use enlarging scales.

The complete designation of a scale should consist of the word Scale, followed by the indication of its ratio as:

- ✓ SCALE 1 : 1 for full size
- ✓ SCALE X : 1 for enlarged scales
- ✓ SCALE 1 : X for reduced scales

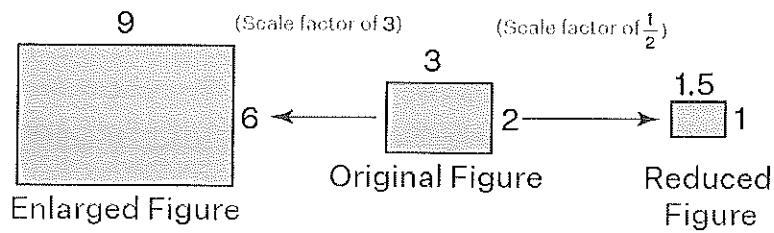

18. Draw Front view, Top View and Right hand side view for following object, using First angle projection method. The Front view is to be drawn by looking in the direction of X.

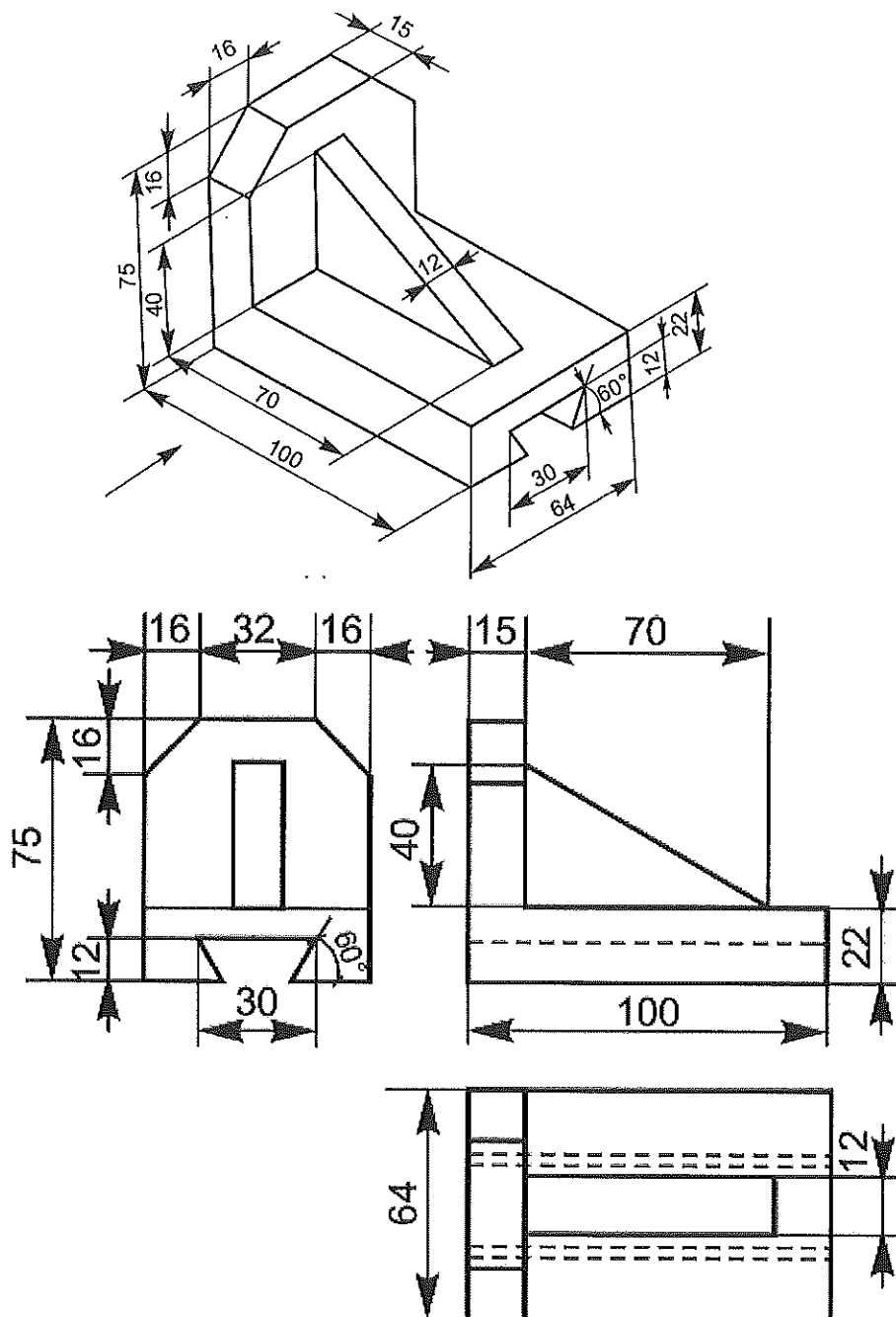

THEORY END-SEM EXAMINATION			
SESSION: 2022-23 (WINTER SEMESTER)			
B.Voc/M.Voc	B.Voc	Semester	3 rd
Course Name / Module	Elementary Drawing		
Course Code	GEN1305		
Date			
Name of the Student		Reg. No.	

INSTRUCTION:
<ul style="list-style-type: none"> • Maximum Marks: 50 • Duration of Examination: 2 Hours • Attempt all questions.
SET-A

Section A	10×1 = 10
-----------	-----------

1. Which plane we need to show the cut section of any geometry as shown in the figure?

- Side plane.
- Front plane.
- Cutting plane.
- None of the above

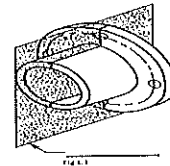

2. What proportion of scale we use to draw a center line?

- 6:2
- 6:1
- 6:3
- 6:4

3. Distance from the observer to the object is finite and the object is viewed from single a point, is a characteristic of which view?

- parallel view
- perspective view
- both (a) and (b)
- none of the above

4. Standard size of drawing sheet as per BIS for A3 sheet?

- 841mm X 1189mm
- 549mm X 841mm
- 420mm X 594mm
- 297mm X 420mm

5. What does this symbol represent?
- 4th angle projection
 - 3rd angle projection
 - 2nd angle projection
 - 1st angle projection

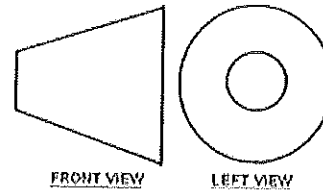

6. Which line type is used to represent the cutting plane line?
- Long chain thick at the end and thin elsewhere
 - to show the hollow areas
 - none of the above
 - long chain thin at the end and thick elsewhere
7. The combination of nominal size and deviation is called
- Upper deviation
 - Lower deviation
 - Fit dimension
 - Deviation
8. What is the purpose of hatching?
- to show the presence of a material
 - to show the hidden areas
 - none of the above
 - both (a) and (b)
9. Which line do we use to represent hidden edges?
- Dash line
 - Dotted line
 - Segmented line
 - None of the above
10. Which of the following is the correct order for the drawing sheet sizes, from smallest to largest?
- A4, A3, A2, A1, A0
 - A0, A1, A2, A3, A4
 - A1, A2, A3, A4, A0
 - A4, A0, A1, A3, A2

Section B

04×04 = 16

11. Define the engineering drawing?
12. What is french curve?
13. What informations should be in engineering drawing?
14. What is GD & T?

Section C

04×06 = 24

15. Differentiate the first angle and third angle.
16. Explain the theory of projection and its type.
17. What is tolerance? Give its terminolgy with the example.
18. Draw the layout of drawing sheet.

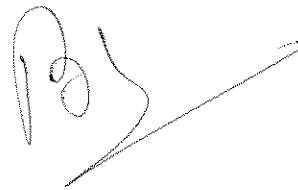



THEORY END-SEM EXAMINATION			
SESSION: 2022-23 (WINTER SEMESTER)			
B.Voc/M.Voc	B.Voc	Semester	3 rd
Course Name / Module	Elementary Drawing		
Course Code	GEN1305		
Date			
Name of the Student		Reg. No.	

INSTRUCTION:
<ul style="list-style-type: none"> Maximum Marks: 50 Duration of Examination: 2 Hours Attempt all questions.
SET-A

Section A	10×1 = 10
-----------	-----------

1. Which plane we need to show the cut section of any geometry as shown in the figure?
- Side plane.
 - Front plane.
 - Cutting plane.**
 - None of the above

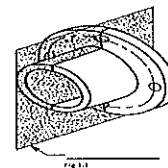

Ans: C

2. What proportion of scale we use to draw a center line?
- 6:2
 - 6:1**
 - 6:3
 - 6:4

Ans: B

3. Distance from the observer to the object is finite and the object is viewed from single a point, is a characteristic of which view?
- parallel view
 - perspective view**
 - both (a) and (b)
 - none of the above

Ans. B

4. Standard size of drawing sheet as per BIS for A3 sheet?
- 841mm X 1189mm
 - 549mm X 841mm
 - 420mm X 594mm
 - 297mm X 420mm**

Ans: D

5. What does this symbol represent?

- a. 4th angle projection
- b. 3rd angle projection
- c. 2nd angle projection
- d. **1st angle projection**

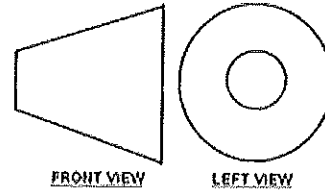

Ans: D

6. Which line type is used to represent the cutting plane line?

- a. **Long chain thick at the end and thin elsewhere**
- b. to show the hollow areas
- c. none of the above
- d. long chain thin at the end and thick elsewhere

Ans: A

7. The combination of nominal size and deviation is called

- a. Upper deviation
- b. Lower deviation
- c. **Fit dimension**
- d. Deviation

Ans: c

8. What is the purpose of hatching?

- a. to show the presence of a material
- b. to show the hidden areas
- c. none of the above
- d. both (a) and (b)

Ans: A

9. Which line do we use to represent hidden edges?

- a. **Dash line**
- b. Dotted line
- c. Segmented line
- d. None of the above

Ans: A

10. Which of the following is the correct order for the drawing sheet sizes, from smallest to largest?

- a. **A4, A3, A2, A1, A0**
- b. A0, A1, A2, A3, A4
- c. A1, A2, A3, A4, A0
- d. A4, A0, A1, A3, A2

Ans: A

Section B

04×04 = 16

1. Define the engineering drawing?

- Ans: Engineering Drawing is the Graphical means of expressing technical details without the barrier of language.
- It is the Universal Language for Engineers.

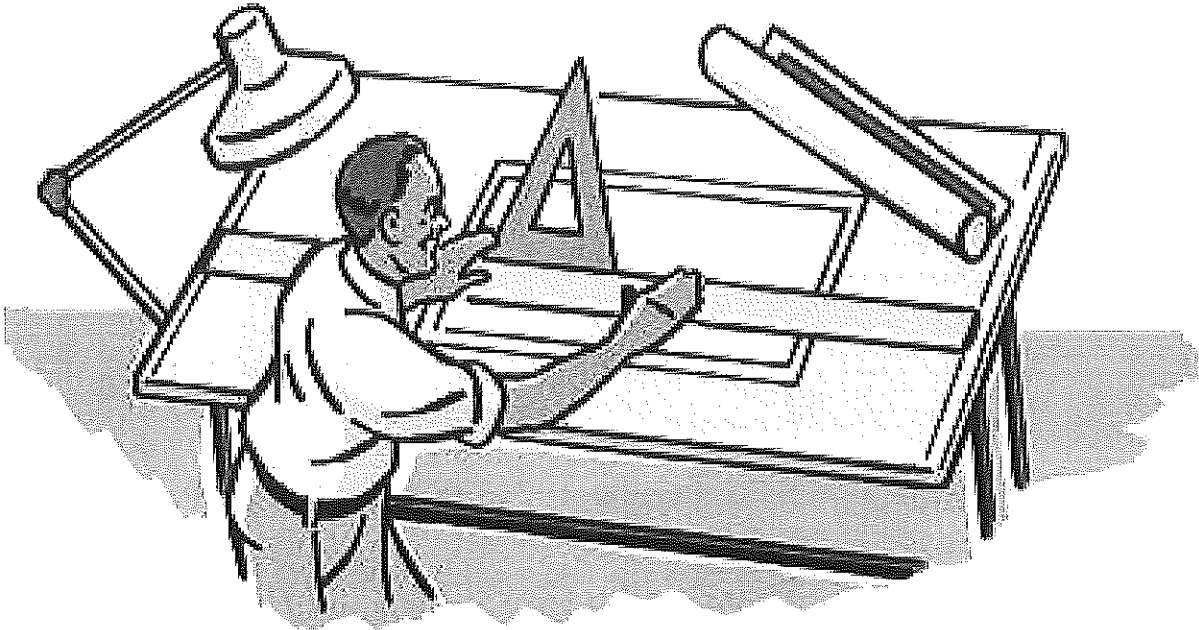

2. What is french curve?

- Ans: French curve is free form template make of acrylic and is used to draw a smooth curve passing through a number of points.

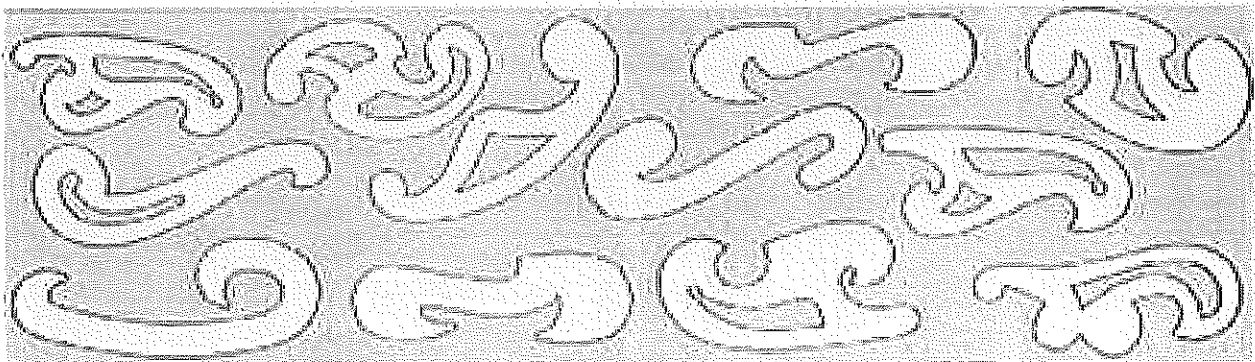

3. What informations should be in engineering drawing?

Ans:

- **Shape of an object**
- **Exact Sizes and tolerances of various parts of the object**
- **The finish of the product**
- **The details of materials**
- **Catalogue no. of the product**

Section C	04×06 = 24
------------------	-------------------

15. Differentiate the first angle and third angle.

Ans:

First angle projection	Third-angle projection
Object is kept in the first quadrant.	Object is assumed to be kept in the third quadrant.
Object lies between Observer and the plane of projection.	Plane of projection lies between the observer and the object.
The plane of projection is assumed to be non-transparent.	The plane of projection is assumed to be transparent.
Front (elevation) view is drawn above the XY line	Front(elevation) view is drawn below the XY line
Top (plan) view is drawn below the XY line	Top (plan) view is drawn above the XY line
Left view is projected on the right plane and vice versa	Left view is projected on the left plane itself
Followed in India ,European Countries	Followed in USA

16. Explain the theory of projection and its type.

- Ans: In engineering, 3-dimensional objects and structures are represented graphically on a 2-dimensional media.
- The act of obtaining the image of an object is termed "projection".

The image obtained by projection is known as a "view".

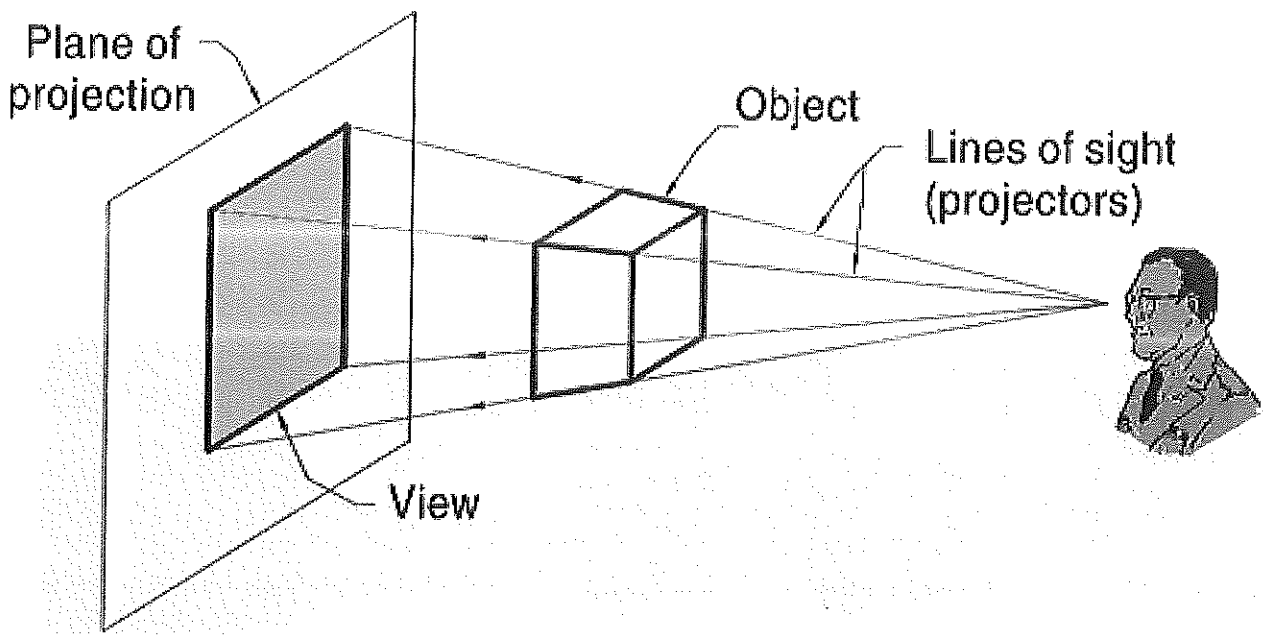

Two projection methods used are:

- Perspective
- Parallel

Parallel projection

- Distance from the observer to the object is infinite projection lines are parallel – object is positioned at infinity.
- Less realistic but easier to draw.

Perspective projection

- Distance from the observer to the object is finite and the object is viewed from a single point – projectors are not parallel.
- Perspective projections mimic what the human eyes see, however, they are difficult to draw.

17. What is tolerance? Give its terminology with the example.

Ans:

a permissible deviation is given, the so-called tolerance.

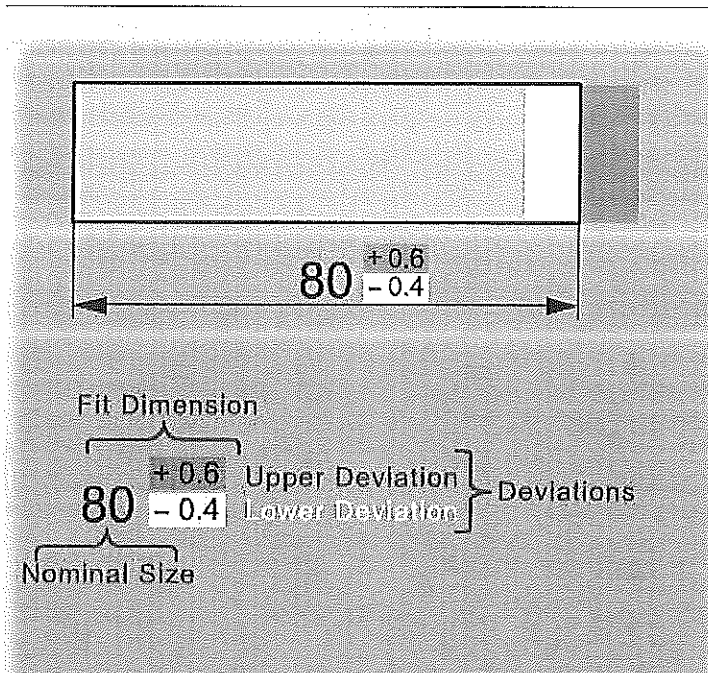

The following are explanations of important terms used in the inspection of dimensional tolerances.

The nominal size is the size 80 mm.

The deviations specify the upper and lower limits of the permissible difference from nominal size.

The upper deviation sets the upper size limit and the lower deviation sets the lower.

The combination of nominal size and deviation is called the fit dimension.

The size of the tolerance depends on the application of the work piece.

18. Draw the layout of drawing sheet.

Ans:

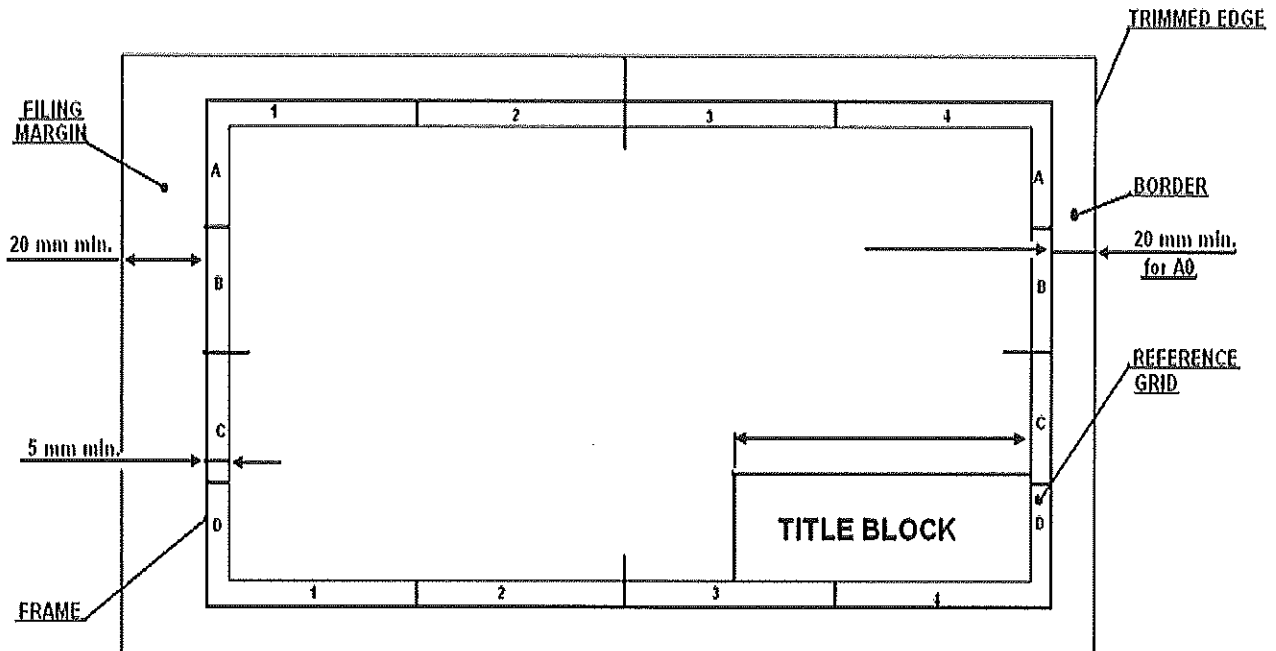

THEORY END-SEM EXAMINATION			
SESSION: 2022-23 (WINTER SEMESTER)			
B. Voc.	Semester	3 rd	
Course Name	Basics of AutoCAD and SolidWorks		
Course Code	GEN1308		
Date			
Name of the Student		Reg. No.	

INSTRUCTIONS
<ul style="list-style-type: none"> • Maximum Marks: 50 • Duration of Examination: 02 Hours • Attempt all questions.

1. Section A (10 objective type questions, each question carries 01 mark)	10×1 = 10
--	------------------

1. What is the command to create a sphere in AutoCAD?
 - a. S.
 - b. Spe.
 - c. Sh.
 - d. Sphere.
2. Which command is used to change the properties of an existing object, such as color or line type?
 - a. Modify.
 - b. Properties.
 - c. Edit.
 - d. Adjust.
3. Which AutoCAD feature allows you to create multiple copies of an object in a specific pattern?
 - a. Array.
 - b. Mirror.
 - c. Offset.
 - d. Rotate.
4. What is AutoCAD?
 - a. A programming language.
 - b. A computer-aided design software.
 - c. An operating system.
 - d. A hardware component.
5. How can you access the AutoCAD command line?
 - a. By clicking on the "Command Line" button in the toolbar.
 - b. By pressing the "Enter" key.
 - c. By right-clicking on the drawing area.
 - d. By selecting the "Tools" menu.
6. What does the "Fillet" command do in AutoCAD?
 - a. Creates a chamfer between two lines or objects.
 - b. Erases a portion of an object.
 - c. Extends the endpoint of a line to meet another object.
 - d. Rounds the edges of two intersecting lines or objects.

7. What is the purpose of the "Hatch" command in AutoCAD?
 - a. To create a pattern of lines or symbols within a closed area.
 - b. To measure the distance between two points.
 - c. To align objects along a specified axis.
 - d. To create a mirror image of an object.
8. Which option is used to create a symmetrical copy of an object in AutoCAD?
 - a. Scale.
 - b. Rotate.
 - c. Offset.
 - d. Mirror.
9. SolidWorks is primarily used for:
 - a. 3D modeling and design.
 - b. 2D drafting and sketching.
 - c. Animation and rendering.
 - d. Spreadsheet calculations.
10. Which command in SolidWorks is used to create a cut or cavity in a part?
 - a. Extrude.
 - b. Revolve.
 - c. Sweep.
 - d. Cut.

2. Section B (04 short answer type questions, each question carries 04 marks)**04×04 = 16**

11. What is the purpose of AutoCAD Software?
12. Explain Polar Tracking.
13. Describe the process of creating and managing dimension styles in AutoCAD. How can you customize dimension appearance and properties to adhere to specific drafting standards?
14. How do layers help in organizing and managing drawing elements, and what best practices would you follow when working with layers?

3. Section C (04 long type questions, each question carries 06 marks)**04×06 = 24**

15. Discuss the importance of constraints in AutoCAD. How do constraints help in creating accurate and editable designs?
16. Describe the process of creating a 2D drawing in AutoCAD. What are the key steps involved, and what tools and commands would you use?
17. Explain Cylinder command in detail with a suitable drawing.
18. Explain the following:
 - a. BLOCKS.
 - b. GROUPS.
 - c. ATTRIBUTES.

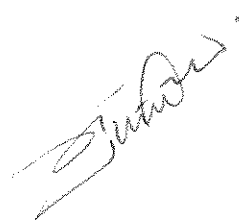

THEORY END-SEM EXAMINATION			
SESSION: 2022-23 (WINTER SEMESTER)			
B. Voc.	Semester	3 rd	
Course Name	Basics of AutoCAD and SolidWorks		
Course Code	GEN1308		
Date			
Name of the Student		Reg. No.	

1. Section A (10 objective type questions, each question carries 01 mark)	10×1 = 10
--	------------------

1. What is the command to create a sphere in AutoCAD?
 - a. S.
 - b. Spe.
 - c. Sh.
 - d. Sphere.**
2. Which command is used to change the properties of an existing object, such as color or line type?
 - a. Modify.
 - b. Properties.**
 - c. Edit.
 - d. Adjust.
3. Which AutoCAD feature allows you to create multiple copies of an object in a specific pattern?
 - a. Array.**
 - b. Mirror.
 - c. Offset.
 - d. Rotate.
4. What is AutoCAD?
 - a. A programming language.
 - b. A computer-aided design software.**
 - c. An operating system.
 - d. A hardware component.
5. How can you access the AutoCAD command line?
 - a. By clicking on the "Command Line" button in the toolbar.
 - b. By pressing the "Enter" key.**
 - c. By right-clicking on the drawing area.
 - d. By selecting the "Tools" menu.
6. What does the "Fillet" command do in AutoCAD?
 - a. Creates a chamfer between two lines or objects.
 - b. Erases a portion of an object.
 - c. Extends the endpoint of a line to meet another object.
 - d. Rounds the edges of two intersecting lines or objects.**

7. What is the purpose of the "Hatch" command in AutoCAD?
- To create a pattern of lines or symbols within a closed area.**
 - To measure the distance between two points.
 - To align objects along a specified axis.
 - To create a mirror image of an object.
8. Which option is used to create a symmetrical copy of an object in AutoCAD?
- Scale.
 - Rotate.
 - Offset.
 - Mirror.**
9. SolidWorks is primarily used for:
- 3D modeling and design.**
 - 2D drafting and sketching.
 - Animation and rendering.
 - Spreadsheet calculations.
10. Which command in SolidWorks is used to create a cut or cavity in a part?
- Extrude.
 - Revolve.
 - Sweep.
 - Cut.**

2. Section B (04 short answer type questions, each question carries 04 marks)

04×04 = 16

11. What is the purpose of AutoCAD Software?

Answer:

- AutoCAD software provides the design and the shape for the products that needs to be created.
- It provides flexible and user friendly features with the tools to design the applications and document the workflows.
- This involves aggregate and import models for the formats and usually allows the design to get created without any change in source model.
- It provides tools to provide the formats by detailed designing the layouts and drawings using the views automatically.
- It also has the provision to create detailed design layouts and views can be drawn automatically using the source model.

12. Explain Polar Tracking.

Answer: When you draw an object, and your pointer is about parallel to AutoCAD axis, what will happen? It's getting sticky and the angle show multiplication of 90 degrees. This is the polar tracking. It will track your pointer when at certain angle and snap your pointer. You can type the relative distance without typing the angle. This is very useful when you need to draw parallel lines. Simply move your pointer, snapped to the axis and type the desired distance. By default, it will track your pointer when it's at 90 deg, 180 deg, 270 deg & 360 deg. We can change the incremental value by right clicking the polar tracking button & choose incremental angle from the list.

13. Describe the process of creating and managing dimension styles in AutoCAD. How can you customize dimension appearance and properties to adhere to specific drafting standards?

Answer:

1. Accessing the Dimension Style Manager:
 - Type DIMSTYLE or DIMSTY in the command line and press Enter.
 - Alternatively, click on the "Annotate" tab in the ribbon, then click on the "Dimension Style" panel and select "Manage Dimension Styles."
2. Creating a new dimension style:
 - In the Dimension Style Manager, click on "New" to create a new dimension style based on an existing style or start from scratch.
 - Give the new style a meaningful name and click "Continue."
3. Setting dimension properties:
 - In the "Primary Units" tab, define the units, precision, and format for dimension values.
 - Specify the desired appearance for dimension lines, arrows, text, and tolerances in the "Lines," "Symbols and Arrows," and "Text" tabs, respectively.
 - Customize additional properties such as fit, tolerance, and text position in the respective tabs.
4. Managing dimension overrides:
 - In the "Overrides" tab, specify whether dimension text and properties can be overridden individually within the drawing.
 - Choose whether to allow or disallow changes to specific dimension properties like text, tolerance, and fit.
5. Associating the dimension style with objects:
 - In the "Fit" tab, define how dimensions should be placed relative to the measured objects, such as centring, aligning, or breaking dimension lines.
 - Specify the text height and dimension scale factors to ensure consistent appearance across different viewports and scales.
6. Saving and using the dimension style:
 - Click "OK" to save the dimension style and exit the Dimension Style Manager.
 - Apply the dimension style to existing or new dimensions by selecting them and choosing the desired style from the properties palette or using the "Style" command.

14. How do layers help in organizing and managing drawing elements, and what best practices would you follow when working with layers?

Answer:

Here's how layers help and some best practices when working with layers:

1. Organization and Control:
 - Layers help organize drawing elements by grouping related objects together. For example, you can create separate layers for dimensions, text, hatches, or specific parts of a design.
2. Drawing Efficiency:
 - Layers help streamline the drawing process by allowing you to apply different properties (e.g., colour, line type, Lineweight) to objects on specific layers. This ensures consistency and saves time by avoiding repetitive settings for each object.

Best practices when working with layers:

1. Consistent Naming and Structure:
 - Use clear and descriptive names for layers to make it easy to understand their purpose and content.
2. Layer Properties:

- Assign appropriate colours, line types, and Lineweight to layers for easy identification and differentiation of objects.
3. Layer Management:
 - Regularly review and manage the layers in your drawing. Remove unused or redundant layers to keep the layer list clean and organized.
 4. Layer Overrides:
 - Use layer overrides sparingly. Instead of modifying layer properties individually, consider creating new layers or using block attributes to accommodate specific variations.
 5. Collaboration:
 - Communicate the layer structure and naming conventions with team members to ensure consistency and ease of collaboration.

3. Section C (04 long type questions, each question carries 06 marks)	04×06 = 24
--	-------------------

15. Discuss the importance of constraints in AutoCAD. How do constraints help in creating accurate and editable designs?

Answer: In AutoCAD, constraints are used to control the geometric properties of objects and maintain their relationships. They enable precise positioning and control over the size, angle, and alignment of objects. Constraints can include horizontal and vertical alignments, parallelism, perpendicularity, tangency, concentricity, and symmetry, among others.

The importance of constraints in AutoCAD includes:

- **Design accuracy:** Constraints ensure that objects maintain their desired relationships and meet design specifications. This leads to accurate and consistent drawings.
- **Editability:** By applying constraints, design changes become easier. Adjusting a constraint automatically updates the associated geometry, maintaining the design intent and reducing the need for manual modifications.

16. Describe the process of creating a 2D drawing in AutoCAD. What are the key steps involved, and what tools and commands would you use?

Answer: The process of creating a 2D drawing in AutoCAD involves several key steps. Here is a general outline of the process along with the tools and commands commonly used:

1. Setting up the drawing:
 - Launch AutoCAD and select the appropriate template or create a new file.
 - Specify the units of measurement and drawing scale using the UNITS command.
 - Set up the drawing limits and grid using the LIMITS and GRID commands.
2. Creating the basic geometry:
 - Start by using the LINE command to draw lines, specifying their starting and ending points.
 - Use the CIRCLE command to draw circles, specifying the centre point and radius.
 - Utilize the ARC command to draw arcs, defining the centre, start point, and end point or angle.
 - Employ the POLYLINE command to draw complex shapes by connecting multiple points with straight or curved segments.
3. Modifying and refining the drawing:
 - Use editing commands such as TRIM, EXTEND, FILLET, and CHAMFER to modify and connect the geometry.
 - Apply the OFFSET command to create parallel copies of lines or curves.
 - Use the ERASE command to remove unwanted geometry.

- Utilize the COPY and MOVE commands to duplicate or relocate objects.
 - Add text annotations using the TEXT command and specify the desired font, size, and style.
4. Applying dimensions and annotations:
- Use the DIMENSION command to add linear, angular, and radial dimensions to the drawing.
 - Specify the dimension style, including text height, arrowheads, and precision.
 - Apply the LEADER command to add annotations with arrows pointing to specific areas.
 - Use the HATCH command to fill closed areas with patterns or solid colours.
5. Organizing the drawing with layers:
- Create and manage layers using the LAYER command.
 - Assign objects to appropriate layers to control visibility and manage drawing elements separately.
 - Set properties such as colour, linetypes, and Lineweight for each layer.
6. Plotting or printing the drawing:
- Set up the plot settings and page setup using the PAGESETUP and PLOT commands.
 - Preview the drawing using the PLOT PREVIEW option.
 - Print the drawing to a physical or digital format using a compatible plotter or printer.

17. Explain Cylinder command in detail with a suitable drawing.

Answer: Command: Cylinder

Alias: CYL

Home Tab -> Modeling Panel -> Cylinder.

Use: To create cylinder. Creating one is very similar to creating a circle, except that you are giving depth to it.

Methods to create cylinder:

1. 3P.
2. 2P.
3. Ttr.

There are two options related to height of cylinder:

1. 2Point.
2. Axis Endpoint.

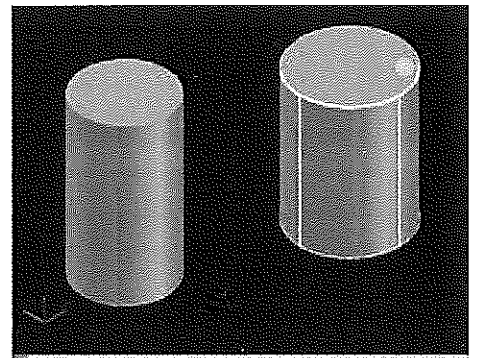

18. Explain the following:

- a. BLOCKS.
- b. GROUPS.
- c. ATTRIBUTES.

Answer:

a. Blocks: Insert symbols and details into your drawings from commercial online sources or from your own designs.

In AutoCAD, a block is a collection of objects that are combined into a single named object. The following are some sample blocks at various scales.

Create a Block Definition

Instead of creating a drawing file to be inserted as a block, you might want to create a block definition directly in your current drawing. Use this method if you do not plan to insert the block into any other drawing. In that case, use the BLOCK command to create the block definition.

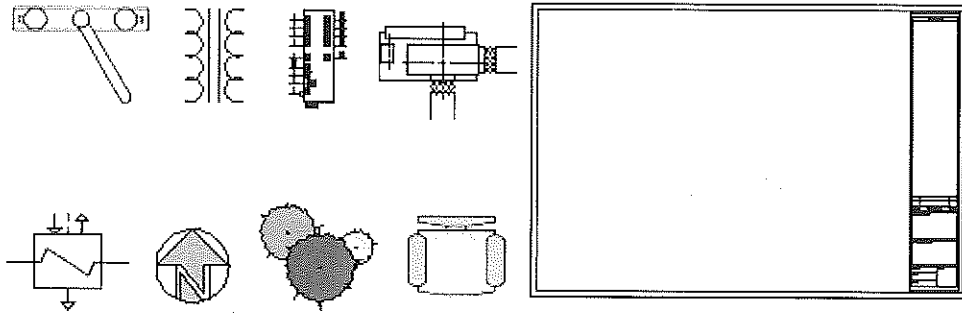

b. Groups:

Working with groups Blocks have lots of features, such as allowing you to resize blocks while inserting, make modifications in blocks that are transferred to all its references in the drawing, use blocks from other drawings, and so on.

Creating groups

Group Objects (Unnamed Group)

The fastest way to group objects is to create an unnamed group.

1. Select the objects you want to group.
2. Click Home tab > Groups panel > Group.

The selected objects are grouped together into an unnamed group, which is assigned a default name such as *A1.

c. Attributes:

An attribute is a label or tag that attaches data to a block. Examples of data that might be contained in an attribute are part numbers, prices, comments, and owners' names.

Attribute information extracted from a drawing can be used in a spreadsheet or database to produce a parts list or a bill of materials. You can associate more than one attribute with a block, provided that each attribute has a different tag.

When you define an attribute, you specify:

- A unique tag that identifies the attribute by name.
- A prompt that can be displayed as the block is inserted.
- A default value that is used if a variable value is not entered at the prompt.

THEORY END-SEM EXAMINATION			
SESSION: 2022-23 (WINTER SEMESTER)			
B. Voc.	Semester	3 rd	
Course Name	Basics of AutoCAD and SolidWorks		
Course Code	GEN1308		
Date			
Name of the Student		Reg. No.	

INSTRUCTIONS
<ul style="list-style-type: none"> • Maximum Marks: 50 • Duration of Examination: 02 Hours • Attempt all questions.

1. Section A (10 objective type questions, each question carries 01 mark)	10×1 = 10
--	------------------

1. By which of the following command, you can draw a rectangle in AutoCAD?
 - a. ARC.
 - b. POL.
 - c. REC.
 - d. CO.
2. What does UCS means? (In the context of CAD)
 - a. User Coordinate System.
 - b. United CAD Software.
 - c. Unite, Cut and Select.
 - d. Unique Coordinate System.
3. Which AutoCAD command is used to modify the length of a line or an arc?
 - a. LENGTHEN.
 - b. TRIM.
 - c. EXTEND.
 - d. STRETCH.
4. How can you create a duplicate of an object in AutoCAD?
 - a. Copy and Paste.
 - b. Move and Rotate.
 - c. Scale and Stretch.
 - d. Mirror and Offset.
5. What is the purpose of the "Polar Tracking" feature in AutoCAD?
 - a. To align objects with the polar axis.
 - b. To track object positions in real-time.
 - c. To draw objects using polar coordinates.
 - d. To create polar diagrams based on object data.
6. What is the purpose of the "Extrude" command in AutoCAD 3D?
 - a. To project a 2D shape onto a 3D plane.
 - b. To rotate a 3D object around a specified axis.
 - c. To modify the height of a 3D object.
 - d. To create 3D objects by stretching a 2D shape.

7. What is the purpose of the "Union" command in AutoCAD 3D?
 - a. To combine multiple 3D objects into a single object.
 - b. To split a 3D object into multiple separate objects.
 - c. To align multiple 3D objects along a common axis.
 - d. To rotate a 3D object around a specified point.
8. Which AutoCAD command is used to create a hollow 3D object by removing a region from a solid?
 - a. INTERSECT.
 - b. SUBTRACT.
 - c. UNION.
 - d. SLICE.
9. Which tool in SolidWorks allows you to measure distances, angles, and other dimensions in a model?
 - a. Sketch tool.
 - b. Measure tool.
 - c. Edit tool.
 - d. View tool.
10. Which command is used to save a SolidWorks file with a different name or in a different location?
 - a. Save As.
 - b. Save All.
 - c. Save Copy As.
 - d. Save Selection.

2. Section B (04 short answer type questions, each question carries 04 marks)

04×04 = 16

11. Explain the difference between AutoCAD 2D and AutoCAD 3D.
12. How can you apply hatching and gradients to objects in AutoCAD? What is their purpose?
13. How can you create a dimension in AutoCAD? What information does it provide?
14. What is the significance of sketches in SolidWorks and how are they used in the modelling process?

3. Section C (04 long type questions, each question carries 06 marks)

04×06 = 24

15. What is the purpose of blocks in AutoCAD? How are they different from regular drawing entities?
16. What is the difference between absolute coordinates and relative coordinates in AutoCAD?
17. Describe the process of creating a section view of a 3D object in AutoCAD.
18. What is SolidWorks and what is its main purpose in the field of automotive engineering?

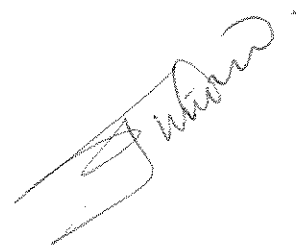

THEORY END-SEM EXAMINATION			
SESSION: 2022-23 (WINTER SEMESTER)			
B. Voc.	Semester	3 rd	
Course Name	Basics of AutoCAD and SolidWorks		
Course Code	GEN1308		
Date			
Name of the Student			Reg. No.

1. Section A (10 objective type questions, each question carries 01 mark)	10×1 = 10
--	------------------

1. By which of the following command, you can draw a rectangle in AutoCAD?
 - a. ARC.
 - b. POL.
 - c. **REC.**
 - d. CO.

2. What does UCS means? (In the context of CAD)
 - a. **User Coordinate System.**
 - b. United CAD Software.
 - c. Unite, Cut and Select.
 - d. Unique Coordinate System.

3. Which AutoCAD command is used to modify the length of a line or an arc?
 - a. **LENGTHEN.**
 - b. TRIM.
 - c. EXTEND.
 - d. STRETCH.

4. How can you create a duplicate of an object in AutoCAD?
 - a. **Copy and Paste.**
 - b. Move and Rotate.
 - c. Scale and Stretch.
 - d. Mirror and Offset.

5. What is the purpose of the "Polar Tracking" feature in AutoCAD?
 - a. To align objects with the polar axis.
 - b. To track object positions in real-time.
 - c. **To draw objects using polar coordinates.**
 - d. To create polar diagrams based on object data.

6. What is the purpose of the "Extrude" command in AutoCAD 3D?
 - a. To project a 2D shape onto a 3D plane.
 - b. To rotate a 3D object around a specified axis.
 - c. To modify the height of a 3D object.
 - d. **To create 3D objects by stretching a 2D shape.**

7. What is the purpose of the "Union" command in AutoCAD 3D?
- To combine multiple 3D objects into a single object.**
 - To split a 3D object into multiple separate objects.
 - To align multiple 3D objects along a common axis.
 - To rotate a 3D object around a specified point.
8. Which AutoCAD command is used to create a hollow 3D object by removing a region from a solid?
- INTERSECT.
 - SUBTRACT.**
 - UNION.
 - SLICE.
9. Which tool in SolidWorks allows you to measure distances, angles, and other dimensions in a model?
- Sketch tool.
 - Measure tool.**
 - Edit tool.
 - View tool.
10. Which command is used to save a SolidWorks file with a different name or in a different location?
- Save As.**
 - Save All.
 - Save Copy As.
 - Save Selection.

2. Section B (04 short answer type questions, each question carries 04 marks)	04×04 = 16
--	-------------------

11. Explain the difference between AutoCAD 2D and AutoCAD 3D.

Answer:

AutoCAD 2D:

AutoCAD 2D focuses on creating two-dimensional drawings or designs. It is primarily used for creating plans, elevations, sections, and other technical drawings that represent objects or structures in a 2D space. In AutoCAD 2D, the drawings are typically created using basic geometric shapes such as lines, arcs, circles, and polygons. These drawings are created on a flat plane and do not have depth or volume.

AutoCAD 3D:

AutoCAD 3D, on the other hand, enables the creation of three-dimensional models and designs. It allows users to work in a 3D environment, representing objects with depth, volume, and realistic perspectives. In AutoCAD 3D, you can create complex solid objects by extruding, revolving, sweeping, or lofting 2D profiles. You can also apply materials, textures, and lighting effects to make the models more visually appealing and realistic.

12. How can you apply hatching and gradients to objects in AutoCAD? What is their purpose?

Answer:

- Select the "Hatch" command from the "Draw" or "Home" tab or type "HATCH" in the command line.
- Choose a hatch pattern from the available library or create a custom pattern.
- Specify the boundaries of the area you want to hatch by selecting the objects or defining a boundary using a closed polyline.
- Adjust the scale, angle, and other properties of the hatch pattern as needed.
- Click inside the boundary to apply the hatch.

Hatching is commonly used in architectural, engineering, and construction drawings to represent different materials such as concrete, bricks, or tiles. It helps provide clarity and visual differentiation to various components or sections of a design.

- Select the object or area where you want to apply the gradient.
- Open the "Properties" palette by typing "PROPERTIES" in the command line or selecting it from the right-click menu.
- In the "Properties" palette, locate the "Color" property and click on the color swatch to open the "Gradient" dialog box.
- Choose the gradient type, such as linear or radial, and set the colors and position of color stops to define the gradient.
- Adjust additional properties like transparency, rotation, or scale of the gradient if desired.
- Click "OK" to apply the gradient to the selected object.

Gradients are often used to create visual depth, lighting effects, or shading in drawings. They can be helpful in representing surfaces, highlighting contours, or adding a sense of realism to 3D models.

13. How can you create a dimension in AutoCAD? What information does it provide?

Answer:

In AutoCAD, you can create dimensions to annotate your drawings and provide important measurements and information. Here's how you can create dimensions in AutoCAD:

- Select the "Dimension" command from the "Annotation" or "Home" tab, or type "DIMENSION" in the command line.
- Specify the first extension line origin by clicking on the object or point you want to dimension from.
- Specify the second extension line origin by clicking on the object or point you want to dimension to.
- Position the dimension line by moving the cursor to the desired location and clicking to place it.
- Adjust the dimension properties such as text style, dimension style, precision, and tolerance settings as needed.
- Repeat the process to create additional dimensions.

AutoCAD provides different types of dimensions, including linear, angular, radial, and diameter dimensions.

- **Linear Dimension:** It provides the length or distance between two points or objects, such as the length of a line or the distance between two corners of a rectangle.
- **Angular Dimension:** It measures the angle between two lines or the angle formed by three points, providing the information about the orientation or inclination of objects.
- **Radial Dimension:** It measures the radius of a circle or arc, providing information about the size and curvature of circular objects.
- **Diameter Dimension:** It measures the diameter of a circle or arc, providing information about the size and width of circular objects.

14. What is the significance of sketches in SolidWorks and how are they used in the modelling process?

Answer:

In SolidWorks, sketches play a crucial role in the modelling process and have significant significance. Here's why sketches are important and how they are used:

1. **Foundation of Geometry:** Sketches serve as the foundation for creating 3D models in SolidWorks. They are 2D representations consisting of lines, arcs, circles, and other geometric entities that define the shape and size of the model.

2. Design Intent: Sketches capture the design intent, which means they define the desired shape and behaviour of the model. By properly dimensioning and constraining the sketch elements, you establish design rules and relationships that guide the model's behaviour when modifications are made.
3. Flexibility and Editability: Sketches are highly flexible and editable. They allow you to easily modify and iterate on the design. You can adjust dimensions, move sketch elements, add or delete entities, and experiment with different design variations.
4. Parametric Modeling: SolidWorks utilizes parametric modelling, where changes made to the sketch propagate through the feature history tree, updating the subsequent features and maintaining design intent. This parametric association allows for easy design modifications and updates.
5. Sketch-Based Features: Many features in SolidWorks are built on sketches. For example, extrusions, revolves, sweeps, and lofts are all based on a sketch. The sketch provides the shape and profile for these features, allowing you to create complex 3D geometry.
6. Constraints and Dimensions: Sketches in SolidWorks can be fully constrained using dimensions and geometric relationships. Constraints ensure that the sketch maintains its intended shape, while dimensions control the size and position of sketch elements. These constraints and dimensions aid in controlling the design and maintaining its accuracy.

3. Section C (04 long type questions, each question carries 06 marks)	04×06 = 24
--	-------------------

15. What is the purpose of blocks in AutoCAD? How are they different from regular drawing entities?

Answer:

In AutoCAD, blocks are used to create reusable content or objects within a drawing. Blocks are different from regular drawing entities in several ways. Here's an explanation of the purpose of blocks and how they differ from regular drawing entities:

Purpose of Blocks:

- Reusability: Blocks allow you to create a set of objects or content that can be reused multiple times within the same drawing or in different drawings.
- Consistency: Blocks ensure consistency and accuracy across drawings. By using blocks, you can maintain uniformity in dimensions, styles, and content throughout your drawings.
- Efficiency: Blocks promote efficiency in drawing creation and editing. Instead of creating and modifying individual entities repeatedly, you can create a block once and then insert it multiple times, reducing redundancy and simplifying editing tasks.
- Parametric Control: Blocks can be created with parametric controls, allowing you to define parameters and attributes associated with the block.

Differences from Regular Drawing Entities:

- Grouping: Blocks allow you to group multiple entities into a single object. When you insert a block, it functions as a single entity, making it easier to move, copy, or edit as a unit.
- Unique Definition: Blocks have a unique definition stored within the drawing file. The definition includes the geometry, properties, and attributes of the block.
- Instance Insertion: Blocks are inserted into the drawing as instances of the block definition. This means that changes made to the block definition affect all instances of that block.
- Block Editor: Blocks have a dedicated Block Editor that allows you to edit the block definition and its properties separately from the rest of the drawing.

16. What is the difference between absolute coordinates and relative coordinates in AutoCAD?

Answer:

- **Absolute Coordinates:** Absolute coordinates are defined using fixed values based on a specific origin point (0,0) in the drawing space. The origin point is typically the lower-left corner of the drawing area. Absolute coordinates consist of X, Y, and optionally Z values. For example, an absolute coordinate could be (5, 10) or (3, 4, 2) in a 2D or 3D drawing respectively. Absolute coordinates are not affected by changes in the drawing or object positions.
- **Relative Coordinates:** Relative coordinates are defined in relation to the last point specified or the most recent point of reference. Instead of providing the absolute position of an object, relative coordinates indicate the direction and distance from a reference point. Relative coordinates are represented using the @ symbol, followed by the distance along the X, Y, and optionally Z axes. For example, if the last point was (5, 10), specifying a relative coordinate of @3, 2 would place the object at (8, 12) relative to the previous point. Relative coordinates are useful for creating objects in relation to existing geometry or for drawing sequences of objects with incremental movements.

17. Describe the process of creating a section view of a 3D object in AutoCAD.

Answer:

To create a section view of a 3D object in AutoCAD, you can follow these steps:

- Open the AutoCAD drawing that contains the 3D object you want to create a section view of.
- Switch to the layout or paper space where you want to create the section view. This is where you will place the resulting section view.
- In the layout, select a suitable viewport to display the section view. If there isn't a viewport, create one by using the MVIEW command.
- Activate the SECTIONPLANE command by typing it into the command line or selecting it from the ribbon or toolbar.
- Specify the location and orientation of the section plane by either picking points or specifying distances and angles. The section plane represents the cutting plane that will define the section view.
- Once you have positioned the section plane, you can adjust its properties such as depth, height, or rotation by using grips or through the Properties palette.
- If necessary, you can also define additional section planes to create multiple section views or to capture different perspectives of the 3D object.
- After finalizing the section plane(s), exit the SECTIONPLANE command.
- Regenerate the layout or update the viewport to display the section view. This can be done by using the REGEN command or by right-clicking on the viewport and selecting "Update" or "Regenerate" option.
- Adjust the scale, position, and annotation of the section view as required. You can add dimensions, notes, or symbols to enhance the clarity and understanding of the section view.
- Save the AutoCAD drawing to preserve the section view and its associated settings.

18. What is SolidWorks and what is its main purpose in the field of automotive engineering?

Answer:

SolidWorks is a 3D computer-aided design (CAD) software widely used in various industries, including automotive engineering and design. It is developed by Dassault Systèmes and offers a range of tools and features specifically designed for creating detailed 3D models and simulations.

In the field of automotive engineering, SolidWorks serves several purposes:

1. **Vehicle Design:** SolidWorks allows automotive designers to create detailed 3D models of vehicles, including the exterior body, interior components, and various mechanical parts. It provides tools for

- sketching, surfacing, and creating complex 3D shapes, enabling designers to visualize and refine their vehicle designs.
2. **Parts and Assembly Design:** SolidWorks enables engineers to design individual components of a vehicle, such as engines, transmissions, suspension systems, and other mechanical parts. It supports the creation of parametric models, allowing engineers to easily modify and iterate on designs, and provides advanced assembly features for designing complex vehicle assemblies.
 3. **Simulations and Analysis:** SolidWorks offers simulation capabilities that allow automotive engineers to perform structural analysis, motion analysis, and fluid flow simulations on their designs. These simulations help evaluate the performance, durability, and safety of automotive components and systems, ensuring they meet industry standards and requirements.
 4. **Prototyping and Manufacturing:** SolidWorks aids in the creation of prototypes and manufacturing-ready designs. It provides tools for generating 2D engineering drawings, creating assembly instructions, and generating bills of materials (BOM). These features streamline the transition from design to manufacturing, supporting efficient production processes.
 5. **Collaboration and Documentation:** SolidWorks facilitates collaboration among automotive design teams and stakeholders by providing tools for sharing models, conducting design reviews, and managing design revisions. It also allows the creation of detailed documentation, including technical drawings, specifications, and reports.